

# **SALDA**

INSTALLATION, OPERATION AND  
MAINTENANCE MANUAL

***AmberAir***

# 1. Table of contents

- 1. Table of contents .....2
- 2. EC Declaration of Conformity .....5
- 3. General information .....6
- 4. Safety precautions .....7
- 5. AmberAir range description.....8
  - 5.1. Legend.....8
  - 5.2. Technical data .....8
  - 5.3. Outdoor design .....14
  - 5.4. Hygienic design .....14
  - 5.5. Side by side design.....14
  - 5.6. Design for coastal environment.....15
  - 5.7. Design for swimming pools.....15
- 6. Components.....16
  - 6.1. Fans .....16
    - 6.1.1. Direct-driven centrifugal fan.....16
    - 6.1.2. Belt-driven centrifugal fans .....18
  - 6.2. Heat recovery systems.....20
    - 6.2.1. Counter-flow plate heat exchanger .....20
    - 6.2.2. Cross-flow plate heat exchanger .....22
    - 6.2.3. Rotary heat exchanger .....25
    - 6.2.4. Run around coils .....27
    - 6.2.5. Rotary heat exchanger with heat pump section.....29
    - 6.2.6. Drainage system .....30
    - 6.2.7. Plate heat exchanger with heat pump section .....32
    - 6.2.8. Cross-Flow section .....33
  - 6.3. Heat exchangers .....34
    - 6.3.1. Water heater.....34
    - 6.3.2. Water cooler .....39
    - 6.3.3. DX cooler.....41
    - 6.3.4. Electrical heater .....44
    - 6.3.5. Steam heater.....47
    - 6.3.6. Gas-fired heater .....48
  - 6.4. Air filters .....50
    - 6.4.1. Panel filter.....50
    - 6.4.2. Pocket filter.....51
    - 6.4.3. EPA / HEPA filter .....54

6.4.4.	Activated carbon cartridges filter .....	56
6.4.5.	Grease filter .....	57
6.5.	Humidifiers .....	59
6.5.1.	Steam humidifier .....	59
6.5.2.	Evaporative humidifier .....	60
6.6.	Damper section .....	61
6.7.	Mixing section.....	62
6.8.	Service section.....	65
6.9.	Droplet eliminator section.....	66
7.	Control system.....	67
8.	Accessories .....	69
8.1.	Base frames .....	69
8.1.1.	Base frame type 1.....	69
8.1.2.	Base frame type 2.....	70
8.2.	Sound attenuator .....	71
8.3.	Flexible connection.....	73
8.4.	Outdoor grille .....	74
8.5.	Hood with net.....	74
8.6.	Roof .....	75
8.7.	Inspection window .....	77
8.8.	Lighting .....	78
8.9.	Pressure taps .....	78
8.10.	Filter contamination control accessories .....	79
9.	Usage .....	81
9.1.	Delivery.....	81
9.2.	Loading, unloading and transportation .....	81
9.2.1.	Unloading unit sections by crane using lifting bars.....	81
9.2.2.	Unloading unit sections by crane using lifting loops.....	84
9.2.3.	Unloading and transport unit sections by fork-lift truck.....	86
9.3.	Storage.....	88
9.4.	Installation .....	89
9.4.1.	Labelling.....	89
9.4.2.	Maintenance side .....	89
9.4.3.	Assembling.....	90
9.4.4.	Applying sealing strip on AmberAir units .....	92
9.4.5.	Ceiling brackets.....	94
9.4.6.	Final disinfection.....	94

9.5. Handles and hinges .....94

9.6. Shutdown and decommissioning.....97

9.7. Fire protection and fire emergency .....98

10. Warranty .....99

11. Checklist for operation and maintenance .....100



## 2. EC Declaration of Conformity

Manufacturer

**SALDA UAB**  
**Ragainės g. 100**

**LT-78109 Šiauliai, Lithuania**  
**Tel.: +370 41 540415**  
**www.salda.lt**

Hereby confirms that the following products - Air handling units:

**AmberAir\***

**(where by „\*“ indicates possible unit design size and modification)**

Provided it was delivered and installed in the facility in accordance with the included installation instructions, comply with all applicable requirements in the following directives:

**Machinery Directive 2006/42/EC**  
**EMC Directive 2014/30/EU**  
**Ecodesign Directive 2009/125/EC**  
**Pressure Equipment Directive 2014/68/EU**

The following harmonized standards are applied in applicable parts:

LST EN ISO 12100:2011 - Safety of machinery - General principles for design - Risk assessment and risk reduction.  
LST EN 60204-1:2006 - Safety of machinery - Electrical equipment of machines - Part 1: General requirements.  
LST EN 60335-1:2012 - Household and similar electrical appliances. Safety. Part 1: General requirements.  
LST EN 60335-2-40:2003 - Household and similar electrical appliances. Safety. Part 2-40: Particular requirements for electrical heat pumps, air-conditioners and dehumidifiers.  
LST EN 60529:1999 - Degrees of protection provided by enclosures (IP code).  
LST EN 61000-6-2:2005 - Electromagnetic compatibility (EMC) - Part 6-2: Generic standards - Immunity for industrial environments.  
LST EN 61000-6-3:2007 - Electromagnetic compatibility (EMC) - Part 6-3: Generic standards - Emission standard for residential, commercial and light-industrial environments.  
LST EN 378-2:2008+A2:2012 - Refrigerating systems and heat pumps - Safety and environmental requirements - Part 2: Design, construction, testing, marking and documentation

Should any alterations be made in the products, this declaration will no longer apply.

**Notified body:** VšĮ Technikos priežiūros tarnyba, Naugarduko g. 41, LT – 03227 Vilnius, Lithuania, identification number 1399.

**Quality:** SALDA UAB activities are in line with the international quality management system standard **ISO 9001:2015**.

Date                    2018-05-04



Darius Buožinis  
Director product development

### 3. General information

Dear customer! Thank you for choosing our product. Please carefully read this installation, operation and maintenance manual. It forms a part of the scope of delivery of your product. In addition, you will get technical data sheet and list of delivered components with each unit. We strongly recommend keeping this documents near the unit where they will be accessible at all times. All persons carrying out work on the machine must have read this manual and adhere to all instructions.



Units tested and produced according to EC directives.



AmberAir range units are Eurovent certified in AHU program.



AmberAir range, sub-ranges H1 and H2 units are Eurovent certified in HAHU program.



Salda – associated member of the Eurovent association (European Committee of Air Handling and Refrigeration).

# VDI 6022

AmberAir units designed according to VDI 6022 Part 1 guideline (Hygiene requirements for ventilation and air-conditioning systems and units).



Salda would like to inform you that based on the Commission Regulation (EU) No 1253/2014 for enforcing directive 2009/125/EC, the operational area of certain AHU within the European Union is regulated by certain conditions.

The AHU can only be used within the EU when it meets the requirements of the ErP directive.

If certain AHU doesn't have CE mark on it, it is strictly forbidden to use it in the EU.

The company reserves the right to make changes of technical data without prior notice.

## 4. Safety precautions

All work in connection with the assembly, installation and commissioning of the unit must be carried out by specially trained personnel. The unit can only be taken into operation if it has been assembled in accordance with these installation and operation manual. All protective devices must be effective.

Do not use the unit for purposes other than its intended use. Use the unit only for the air handling (air filtration, heating, cooling, humidifying, dehumidifying and mixing).

Use special clothing and be careful while performing maintenance and repair jobs.

Do not place fingers or other foreign objects through inlet or exhaust guards or into connected duct. Should a foreign object enter the unit, immediately disconnect power source. Before removing foreign object, make sure that any mechanical motion has stopped, the heater has cooled down and the restart of the unit is not possible.

Do not connect to any other power voltage source than indicated in the documentation and identification plate.

Do not place or operate unit on unsteady surfaces and base frames. Mount the unit firmly to ensure safe operating.

Do not use water or another liquid to clean electrical parts or connections. If you notice water on electrical parts or connections, stop operating the unit.

Do not make any electrical connections when the power is on.

Before maintenance and repair, the unit must be switched off by the supply-disconnecting device, which must be locked with a padlock.

Before cleaning with steam, make sure that there are no people inside the unit.

For work on unit elements and assemblies that not covered in this document, refer to the separate manual.

Air handling units must be properly grounded.

Always observe all relevant local standards and statutory regulations.

## 5. AmberAir range description

### 5.1. Legend

AmberAir 1-KR MD50+ R H2

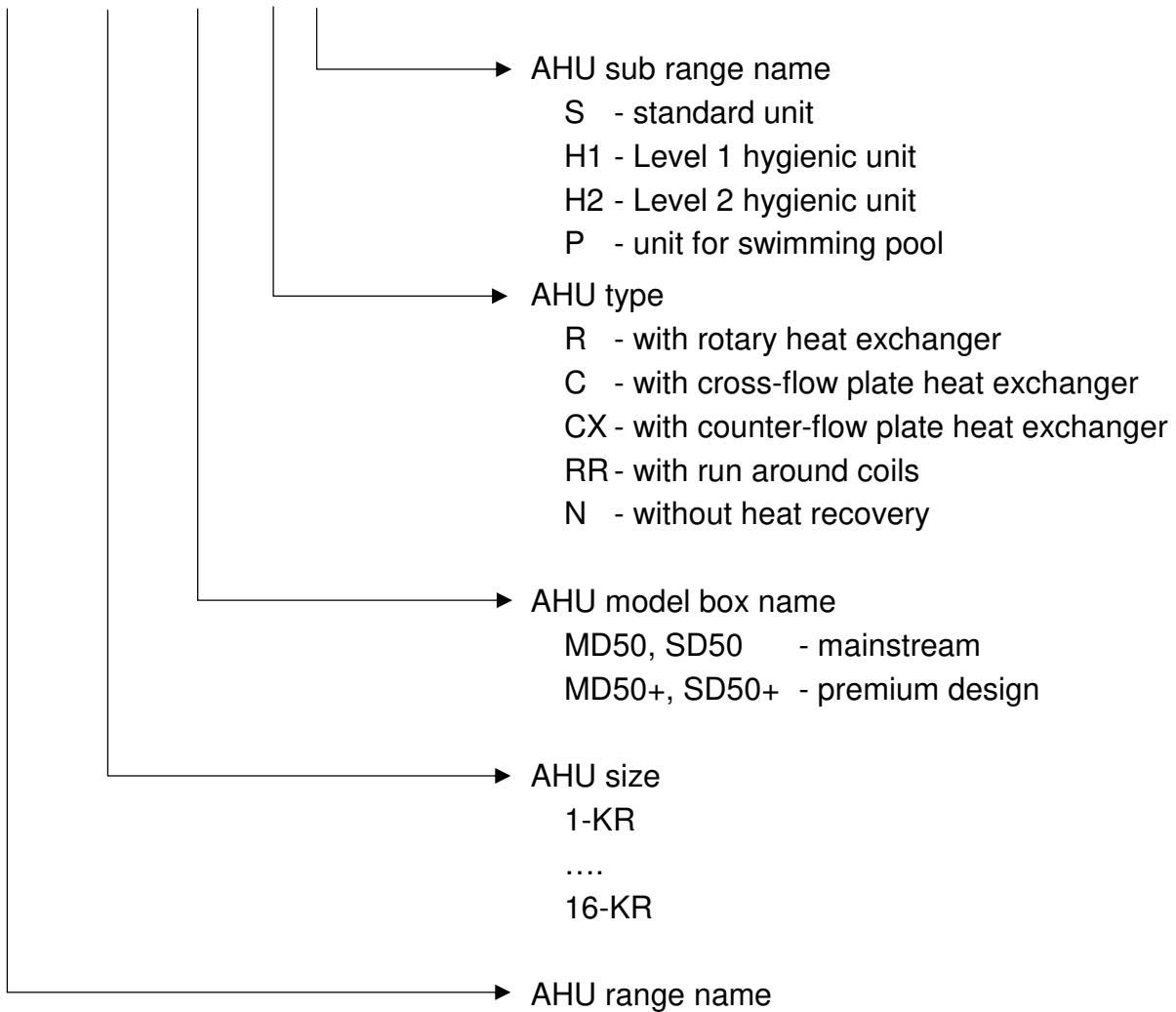

### 5.2. Technical data

AmberAir AHU range is produced in 16 different sizes (KR). Air handling units are produced in modular sections. Operation limits: -40°C / +60°C (it may be different for some of the components).

The rigid casing is made from aluminium profiles and panels. Four different casing model boxes available: MD50, SD50, MD50+ and SD50+. Technical data comparison given in the following tables.

Table 5.2.1 EN 1886:2008 data

Model Box	MD50	SD50	MD50+	SD50+
Casing strength class	D2(M)	D1(M)	D2(M)	D1(M)
Casing air leakage class at -400Pa	L1(M)	L1(M)	L1(M)	L1(M)
Casing air leakage class at +700Pa	L1(M)	L1(M)	L1(M)	L1(M)
Filter bypass leakage class	F9(M)	F9(M)	F9(M)	F9(M)
Thermal transmittance class	T3	T3	T3	T2
Thermal bridging factor class	TB4	TB4	TB2	TB1

Table 5.2.2 Acoustical insulation

Model Box	125Hz	250Hz	500Hz	1000Hz	2000Hz	4000Hz	8000Hz
MD50	10dB	20dB	29dB	24dB	21dB	27dB	29dB
SD50	13dB	11dB	14dB	18dB	19dB	19dB	36dB
MD50+	15dB	14dB	27dB	32dB	32dB	41dB	44dB
SD50+	13dB	11dB	14dB	18dB	19dB	19dB	36dB

Table 5.2.3 Technical data

Model Box	MD50	SD50	MD50+	SD50+
Casing profiles options	Aluminium		Aluminium without thermal break	
	Anodized aluminium		Anodized aluminium without thermal break	
Corners	Plastic			
Corners flammability (UL 94)	HB			
Thickness of double skin panel	45.5mm			
Insulation material	Stone wool	Polyurethane foam	Stone wool	Polyurethane foam
Insulation material density	<95kg/m3	45kg/m3	<95kg/m3	45kg/m3
Insulation material thermal conductivity	0.033W/mK	0.024W/mK	0.033W/mK	0.024W/mK
Insulation material fire reaction class (EN 13501-1:2007)	A1	B – s2 d0	A1	B – s2 d0

Table 5.2.3 Technical data

Model Box	MD50	SD50	MD50+	SD50+
External sheet metal thickness and coating options	0.7mm Zn	0.5mm Zn polyester painting RAL 7040	0.7mm Zn	0.5mm Zn polyester painting RAL 7040
	0.7mm AluZn 185		0.7mm AluZn 185	
	0.7mm Zn different RAL powder coating		0.7mm Zn different RAL powder coating	
	0.8mm AISI 304		0.8mm AISI 304	
	0.8mm AISI 316		0.8mm AISI 316	
Internal sheet metal thickness and coating options	0.7mm Zn	0.5mm Zn	0.7mm Zn	0.5mm Zn
	0.7mm AluZn 185	0.5mm AluZn 185	0.7mm AluZn 185	0.5mm AluZn 185
	0.8mm AISI 304	0.5mm AISI 304	0.8mm AISI 304	0.5mm AISI 304
	0.8mm AISI 316		0.8mm AISI 316	
Base frame options	1-9KR: 3mm galvanized steel	1-9KR: 3mm powder coated galvanized steel	1-9KR: 3mm galvanized steel	1-9KR: 3mm powder coated galvanized steel
	1-9KR: 3mm powder coated galvanized steel		1-9KR: 3mm powder coated galvanized steel	
	10-16KR: 4mm powder coated steel			

All AmberAir casing model boxes have rounded internal corners, which prevents accumulation of dust and dirt, facilitates cleaning and makes it possible to use in a hygienic unit design. It is possible to select different external and internal sheet metal materials for separate sections in the same AHU.

AmberAir MD50+ and SD50+ have thermal bridging factor class TB1 – it eliminates possibilities for condensate occurrence on outer surface of the unit. AmberAir MD50 and SD50 have thermal bridging factor class TB4 – under certain ambient conditions condensate may occur on outer surface of the unit.

Below illustrates AmberAir MD50, AmberAir SD50, AmberAir MD50+ and AmberAir SD50+ cross-sections.

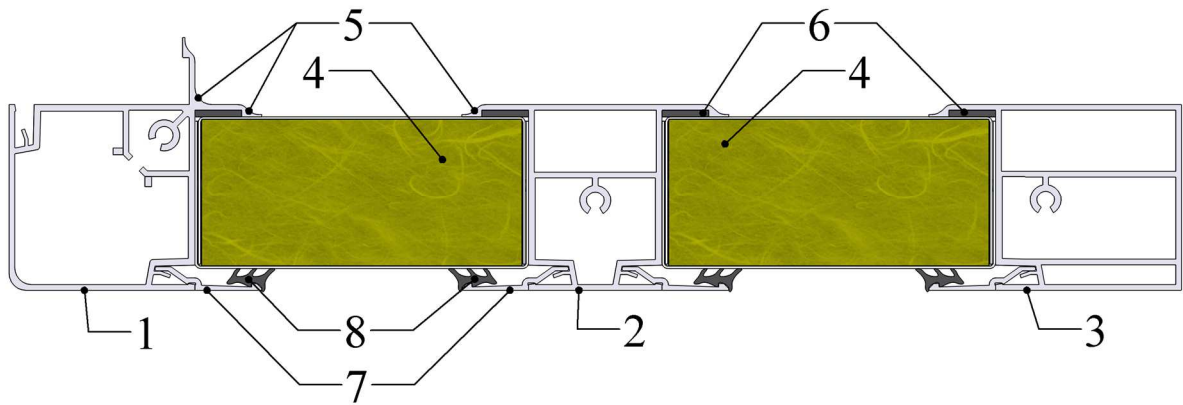

Figure 5.2.1 - AmberAir MD50 cross-section.

- 1 – Corner profile, 2 – intermediate profile, 3 – special corner profile for connection between two sections, 4 – double skin stone wool panel, 5 - rounded profile corners, 6 – non-porous gasket fitted in special groove, 7 – panel block aluminium profile, 8 – panel block gasket

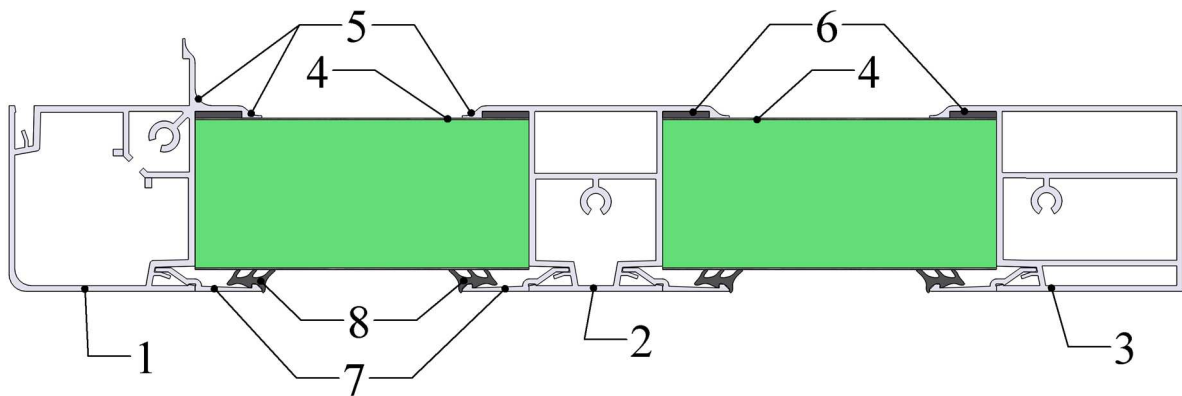

Figure 5.2.2 - AmberAir SD50 cross-section.

- 1 – Corner profile, 2 – intermediate profile, 3 – special corner profile for connection between two sections, 4 – double skin polyurethane foam panel, 5 - rounded profile corners, 6 – non-porous gasket fitted in special groove, 7 – panel block aluminium profile, 8 – panel block gasket

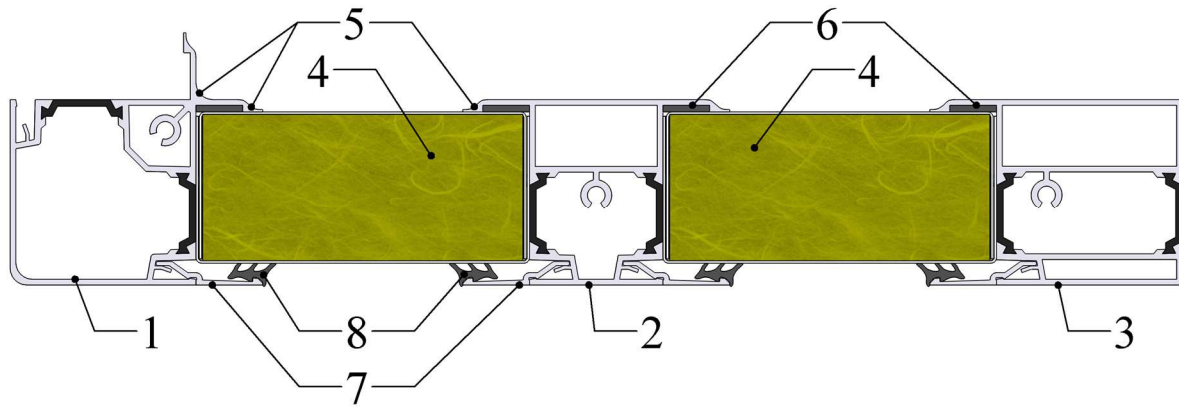

Figure 5.2.3 - AmberAir MD50+ cross-section.

- 1 – Corner profile with thermal break strips, 2 – intermediate profile with thermal break strips, 3 – special corner profile with thermal break strips for connection between two sections, 4 – double skin stone wool panel, 5 - rounded profile corners, 6 – non-porous gasket fitted in special groove, 7 – panel block aluminium profile, 8 – panel block gasket

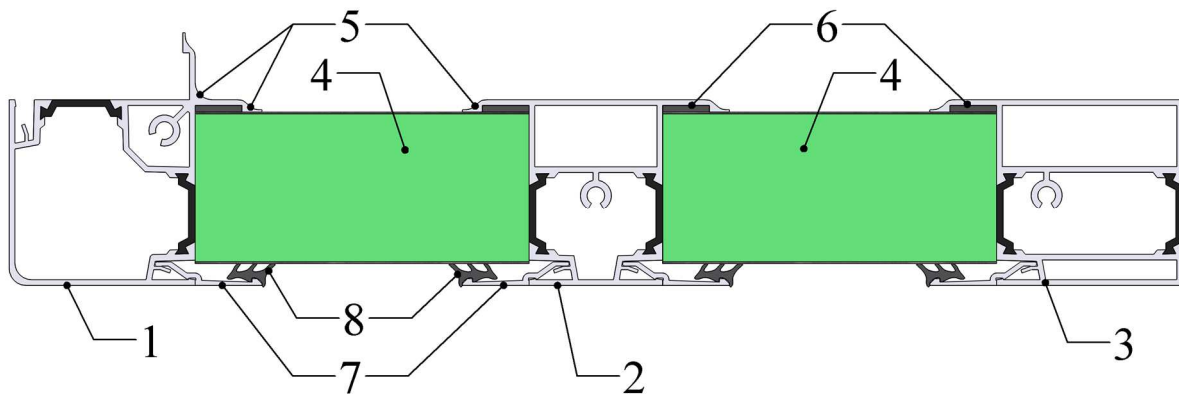

Figure 5.2.4 - AmberAir SD50+ cross-section.

- 1 – Corner profile with thermal break strips, 2 – intermediate profile with thermal break strips, 3 – special corner profile with thermal break strips for connection between two sections, 4 – double skin polyurethane foam panel, 5 - rounded profile corners, 6 – non-porous gasket fitted in special groove, 7 – panel block aluminium profile, 8 – panel block gasket



Unit sections width and height depend on the unite size and don't depend on the casing model box type (see Table 5.2.4). The sections lengths depends on the specific components fitted into the section (eg. cooler, heater, fan, etc.). You will find the exact drawing of your purchased AHU in its Technical data sheet.

Table 5.2.4 Section sizes

Size	Width (mm)	Height (mm)
1-KR	910	490
2-KR	1060	560
3-KR	1080	775
4-KR	1360	775
5-KR	1360	860
6-KR	1660	860
7-KR	1660	1100
8-KR	1970	1100
9-KR	2160	1130
10-KR	2010	1400
11-KR	2600	1400
12-KR	2010	1700
13-KR	2010	2010
14-KR	2600	1700
15-KR	2600	2010
16-KR	2600	2600

### 5.3. Outdoor design

AmberAir air handling units are available in outdoor design. Units are equipped with roofs, outdoor grilles (option) and hood (option). They provide protection from rainy and snowy weather. All doors with hinges and handles are equipped with wind protection device to provide safe access to the unit in windy conditions. Inspection windows have covers to protect inner components from sunlight. Control section has integrated heater for its components.

We recommend choosing powder coated external sheet metal for AmberAir MD50 and MD50+ outdoor unit's panels (corrosion protection class C3 according to EN ISO 12944-2:1998). AmberAir SD50 and SD50+ panel's external sheet metal always has special polyester painting which comply with corrosion protection class C4 according to EN ISO 12944-2:1998.

### 5.4. Hygienic design

AmberAir MD50+ and SD50+ air handling units are available in hygienic design. These units has following features:

- Level 1 or Level 2 HAHU.
- Smooth internal surface prevents accumulation of dust and dirt, facilitates easy cleaning and disinfection of the unit. Joints between panels and frame profiles at the floor are sealed to create closed surface for Level 2 units.
- Components of the unit are easy accessible for cleaning on the suction and pressure sides (via service sections) or quickly removable.
- Only direct driven (plug) fans used, as they are easy to clean.
- All non-metallic parts excluding paints but including sealants, gaskets, filters, etc. with surface in the air stream  $> 5 \text{ cm}^2$  comply with EN ISO 846. The maximum allowed growth rate for microorganisms according Table 4 and 5 of ISO 846 is 1.
- All internal metallic surfaces are made from materials with minimum corrosion protection class C3 in accordance with EN ISO 12944-2:1998 or from aluminium.
- Stainless steel AISI 304 drip trays with slope towards a water drain.
- Plate heat exchanger section with drip tray on supply air side and extract air side.
- All door locks, handles and hinges are outside of the unit.
- Blind rivets are used inside of the unit.
- All sealing and gasket materials are closed cell structure (non-porous), abrasion resistant, emissions free and odourless. They do not absorb moisture and not provide a nutrient substrate for microorganisms.
- Stone wool with glass fibre facing removable silencer's baffles.
- All necessary requirement checked by selection software during unit design.

### 5.5. Side by side design

AmberAir air handling units with cross flow, counter flow and rotary heat exchangers are available in side by side design. Plate heat exchangers is mounted horizontally, other supply and exhaust air sections are stacked in horizontal plane, not vertically as usual. Rotary heat exchanger is mounted vertically, other supply and exhaust air sections are stacked in horizontal plane, not vertically as usual.

## 5.6. Design for coastal environment

AmberAir design for coastal environment is dedicated to environment, which is considered at risk for chloride-related corrosion. Generally, locations within 9 to 18 km of salt water are considered at risk for chloride-related corrosion, but local weather patterns and the performance of metals near the site should be evaluated prior to environment selection in AHU selection software.

AmberAir design for coastal environment has an increased corrosivity resistance with upgraded casing elements as follows:

- Casing profile from anodized aluminium;
- Internal and external metal surfaces complies with corrosivity category C4 requirements (EN ISO 12944-2:1998) or from aluminium;
- Drip trays are made of AISI 304 or AISI 316;
- Plates of coils and heat exchangers are covered by epoxy coating.

## 5.7. Design for swimming pools

AmberAir Pool air handling units are available in special design intended for use in swimming pools. These air handling units have been designed to create an ideal microclimate for indoor swimming pool premises. Depending on settings and air parameters, smart control automatically ensures air quality parameters by extracting excessive humidity, supplying fresh air, returning most of the extracted air heat, and maintaining the required temperature of supplied air.

Main features:

- Cross-flow or counter-flow heat exchangers, with or without heat pump;
- Dampers are equipped with actuators designed for swimming pools (IP 66);
- Special control programs for different swimming pool modes;
- Casing profile from anodized aluminium;
- Internal metal surfaces complies with corrosivity category C4 requirements (EN ISO 12944-2:1998) or from aluminium;
- Drip trays are made of AISI 304 or AISI 316.

Refer to separate „AmberAir Pool IOM” for more information about control modes of AmberAir Pool air handling units. All other information from this manuals also applies for AmberAir Pool air handling units.

## 6. Components

### 6.1. Fans

#### 6.1.1. Direct-driven centrifugal fan

##### Description:

Direct-driven centrifugal fans (plug fans) with one of the following motor and impeller combination:

1. AC motor with metal or plastic impeller, motor protection class IP 55;
2. EC motor with metal or plastic impeller, motor protection class IP 54;
3. EX motor with metal impeller, motor protection class IP 55;
4. PM motor with metal impeller, motor protection class IP 54.

Pressure gauge is available as option with special scale for airflow monitoring.

##### Electrical connection:

1. Electrical connection may only be undertaken by technically trained personnel.
2. A lockable safety switch must be installed near the fan unit access door.
3. Before making the electrical motor connections, compare the connection specifications with the specifications on the motor identification plate.
4. For hygienic units with internal section height below 1.6m fan shall be removable. In case the unit ordered without electrical connection make electrical connection in such way that withdrawal of the fan can be performed by maintenance personal only, without the help of an electrician (No need to undo electrical connection, only mechanical disassembly and only opening of electrical socket is allowed).
5. Observe the fan / motor manufacturer's operating instructions.
6. Refer to separate "Electrical installation, operation and maintenance manual" document for more information.

##### Setting up the unit:

1. The fan should be checked for mechanical oscillations after installation. If the amount of fan oscillation is larger than 2.8 mm/s, (measured on the end plate of the impeller side of the motor bearing), the motor/impeller unit must be examined by specialists and, if necessary, rebalanced.
2. Check the current consumption!
3. Check the direction of rotation (the rotation direction arrow is on the impeller base plate or on the fan housing).
4. Do not exceed the maximum operating speed. Speed controllable through a frequency converter. Do not exceed the maximum operating frequency.

##### Maintenance and cleaning:

1. **WARNING!** Before opening the door, the fan must be switched off, isolated and allowed to run down (at least two minutes).
2. The fan should be checked for mechanical oscillations every 12 months. The maximum permissible oscillation intensity is 2.8 mm/s (measured at the motor-bearing impeller side).
3. For all maintenance and cleaning work:
  - The fan impeller must be at a standstill!

- Power supply is interrupted and secured against restoration!
  - Verify the absence of voltage!
4. Observe the fan manufacturer's operation instructions.
  5. Observe the motor manufacturer's operating instructions.
  6. Check the impeller, in particular the weld-seams, for possible cracks.
  7. Flexible connection between fan and casing is to be checked every 1 month. Unsealed connection leads to breakdowns and danger from escaping transported medium and must be replaced.
  8. Regularly inspect and clean where necessary to prevent imbalance due to ingress of dirt. Clean the fan's flow area. Maintenance interval in accordance with the degree of contamination of the impeller (at least once in 6 months).
  9. You can clean the entire fan with a moist cloth. Do not use high-pressure cleaners. Do not use any aggressive, paint solvent cleaning agents when cleaning.

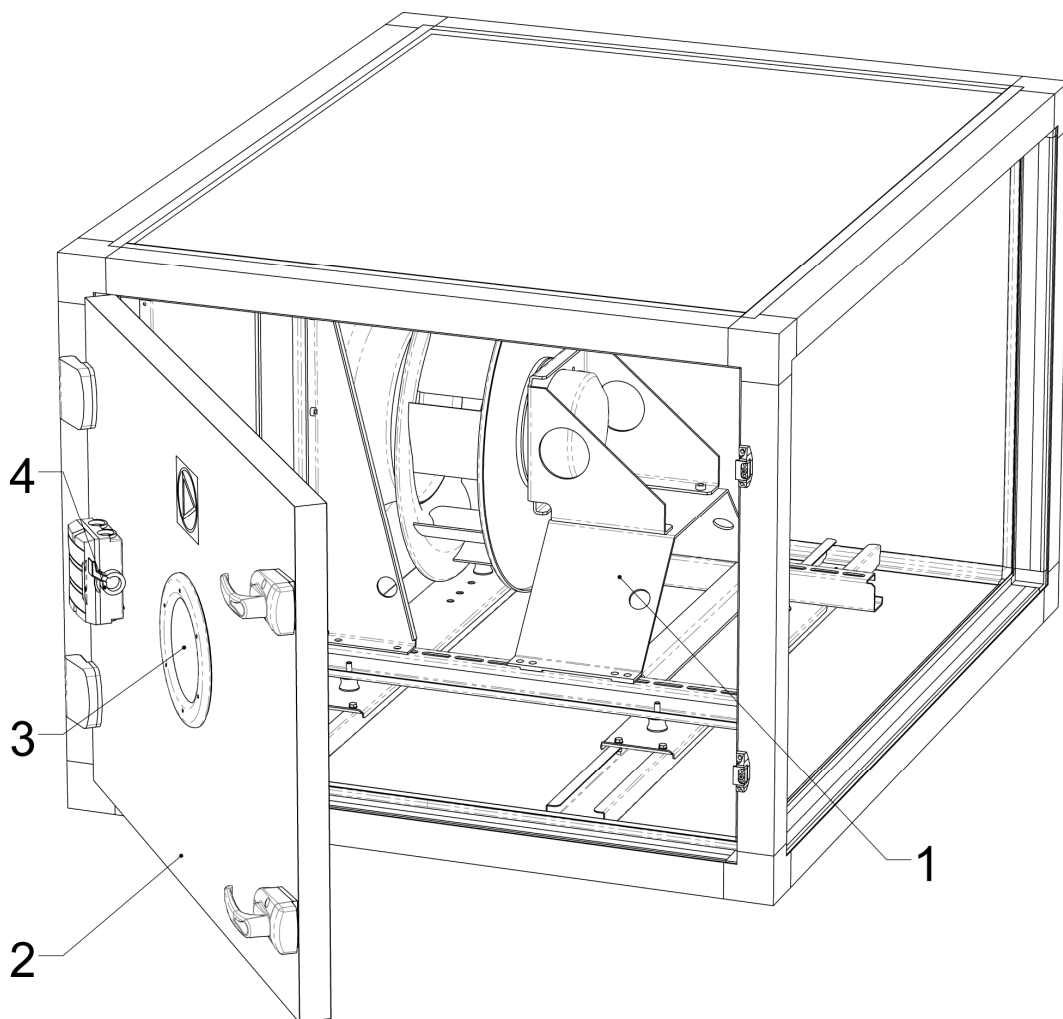

Figure 6.1.1.1 - Direct-driven centrifugal fan section.

- 1 - Plug fan on anti-vibration mounts, 2 – door with lockable handle, 3 – inspection window (optional), 4 – safety switch (optional).

### 6.1.2. Belt-driven centrifugal fans

#### Description:

Belt-driven centrifugal fans produced with forward curved or back curved impeller and AC motor. Motor protection class IP 55.

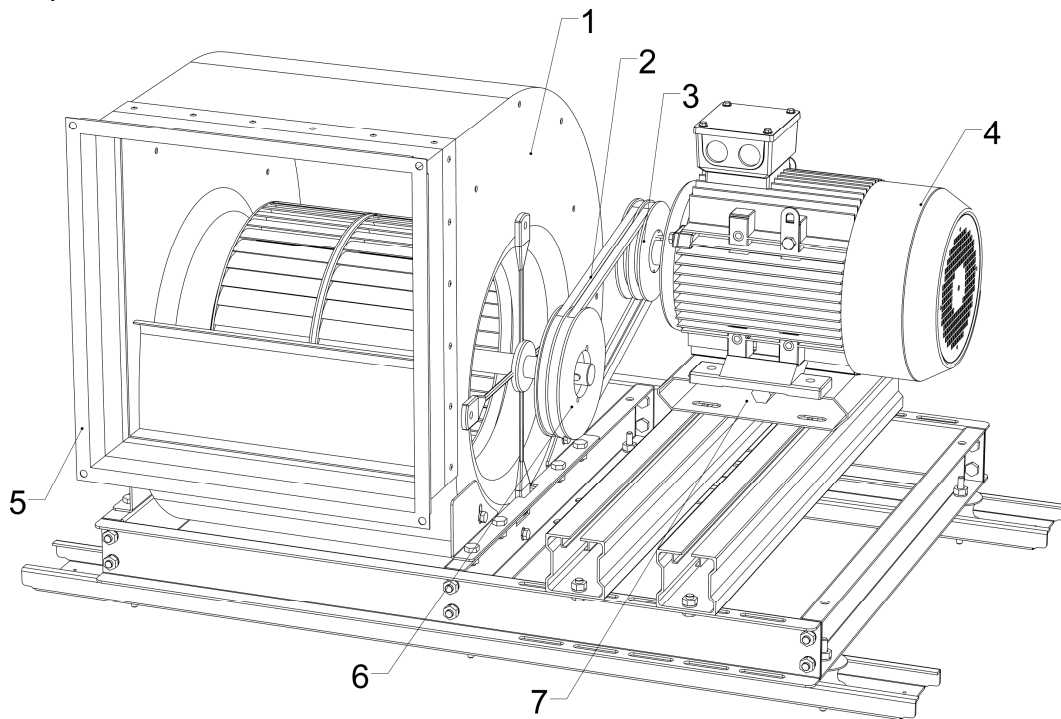

Figure 6.1.2.1 - Belt-driven centrifugal fan section.

1 – Belt-driven fan on anti-vibration mounts, 2 – belts, 3 – motor's pulley, 4 – motor, 5 – flexible connection, 6 – fan's pulley, 7 – belts tensioning mechanism.

#### Electrical connection:

1. Electrical connection may only be undertaken by technically trained personnel.
2. A lockable safety switch must be installed near the fan unit access door.
3. Before making the electrical motor connections, compare the connection specifications with the specifications on the motor identification plate.
4. Observe the fan / motor manufacturer's operating instructions.
5. Refer to separate "Electrical installation, operation and maintenance manual" document for more information.

#### Setting up the unit:

1. Check the current consumption!
2. Check the direction of rotation of the impeller (the rotation direction indicated by arrow).
3. Do not exceed the maximum operating speed.
4. Check fan smooth running. There should be no unusual oscillation or vibration.
5. After one hour of continuous run, stop the fan and check belt tensioning and, if necessary, re-tension the belts; after 3-4 days of operation check again the V-belt tension. Minimum test load ( $F_p$ , [N]) and belt displacement ( $E$ , [mm]) at minimum test load indicated in AHU's technical datasheet.

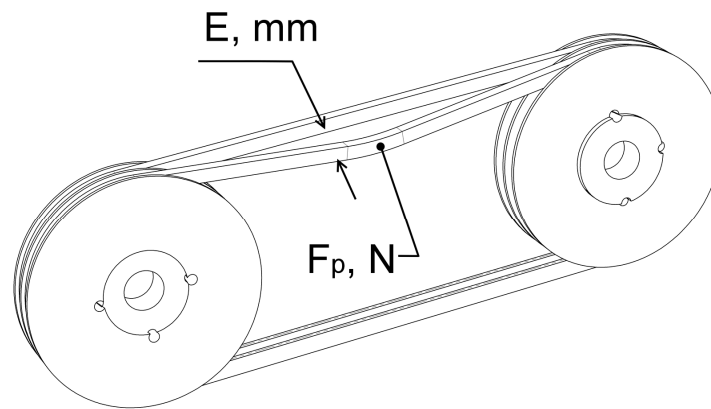

Figure 6.1.2.2 - Belts tension check.

$F_p$ , [N] – minimum test load,  $E$ , [mm] – belt displacement.

#### Bearings:

1. Like all components, the bearings must be periodically checked and if required cleaned and re-lubricated.
2. The base and R-version fans are supplied with pre-greased sealed for life ball bearings. These bearings guarantees a life of 20.000 hours at peak performance. The maintenance of this type of bearing consists of cleaning its external surfaces and inspection to detect any possible abnormal operation or defective gaskets. If the latter is detected, the bearings have to be replaced. By changing the bearings it's necessary to change the rubber too.
3. The T-version fans are supplied with re-greasable ball bearings with plummer block.
4. The TZAF T2, TZAF FF T2, NTHZ T2 fans from size 560 are supplied with splitted housing ball or roller bearing type. These bearings are regreasable and we recommend to substitute completely the grease after 2 re-lubrications.
5. Refer to fan manufacturer's operating instruction for detailed information.

#### Maintenance and cleaning:

1. **WARNING!** Before opening the door, the fan must be switched off, isolated and allowed to run down (at least two minutes).
2. It's recommended to check every 1 month the belt tension and the alignment of the V-belts. Tension the belts when they are vibrating, loose or when belts are changed. Check the alignment of the wheel against the shaft and the conditions of the fixing bolts.
3. If one belt is broken off it is necessary to substitute the whole set of bells.
4. Flexible connection between fan and casing parts is to be checked every 1 month. Unsealed connection leads to breakdowns and danger from escaping transported medium and must be replaced.
5. Observe the fan manufacturer's operation instructions.
6. Observe the motor manufacturer's operating instructions.
7. Regularly inspect and clean where necessary to prevent imbalance due to ingress of dirt. Clean the fan's flow area. Maintenance interval in accordance with the degree of contamination of the impeller (at least once in 6 months).
8. You can clean the entire fan with a moist cloth. Do not use high pressure cleaners. Do not use any aggressive, paint solvent cleaning agents when cleaning



## 6.2. Heat recovery systems

### 6.2.1. Counter-flow plate heat exchanger

#### Description:

In the counter-flow plate heat exchanger, the warm extract air and the cool fresh air, separated by thin plates, pass each other in counter-flow. No mixing of the two air streams takes place. Therefore, the transmission of dirt, odours, moisture, bacteria, etc. is impossible. Heat transmitted from extract air to fresh air purely by conduction because of the temperature difference between the two air streams: the warm extract air cooled down and the cool fresh air heated up.

Counter-flow plate heat exchanger section divided in separate parts from size 12-KR (double deck) or 4-KR (side by side) due transportation reasons. Refer to separate assembly manual for assembly of such section.

#### Types:

1. Counter-flow plate heat exchanger double deck;
2. Counter-flow plate heat exchanger side by side.

#### Standard plate heat exchangers assembly components:

1. Aluminium plate heat exchanger;
2. Stainless steel drip tray on extract air side;
3. By-pass damper for performance control and freezing prevention.

#### Optional components:

1. Droplet eliminator (stainless steel frame, plastic profile) on extract air side;
2. Stainless steel drip tray on supply air side.

#### Electrical connection:

1. Electrical connection may only be undertaken by technically trained personnel.
2. A lockable safety switch must be installed near the fan unit access door.
3. Refer to separate "Electrical installation, operation and maintenance manual" for by-pass valve actuator connection.

#### Maintenance:

1. Check if gaps between the heat exchangers plates are not contaminated. Clean if necessary.
2. Check the drainage system (see 6.2.6. Drainage system).
3. Regular check if drip tray is tight. Clean drip tray and drain piping.
4. Check if bypass damper works properly.
5. Check if the heat exchanger's sealing elements are not harmed (sealant, sealant strips). Repair if necessary.

#### Cleaning:

1. Cleaning sequence when the heat exchanger is in section:
  - Clean dust with soft brush;
  - Blow out dirt with the blower.



## 2. Cleaning sequence when heat exchanger is pulled out:

- The heat exchanger is cleaned with tepid water and alkaline mixture which makes no corrosion to aluminium;
- Do not use direct water flow or water blowers. It can spoil heat exchanger.
- Put the heat exchanger back after cleaning.
- Seal it hermetically; otherwise, the heat exchanger will not work properly!

### Dismantling:

1. Release panel blocks 2;
2. Take off service door 1, panels 3 and aluminium profiles 4;
3. Open quick-release mechanism 9;
4. Unscrew screws to unfasten the by-pass damper 6
5. Pull out by-pass damper 6, by-pass chamber 5 and heat exchanger 7;
6. Do not damage sealing strips while withdrawing the heat exchanger. If sealing strips are damaged change them with new ones;
7. The heat exchanger is mounted conversely to dismantlement sequence.
8. Be sure that the heat exchanger installed hermetically.

### Important:

1. Do not damage the heat exchanger's plates while mounting it into section.
2. Do not use the heat exchanger without filter in air handling unit! Filter must be installed before heat exchanger both in supply and in exhaust airflow.

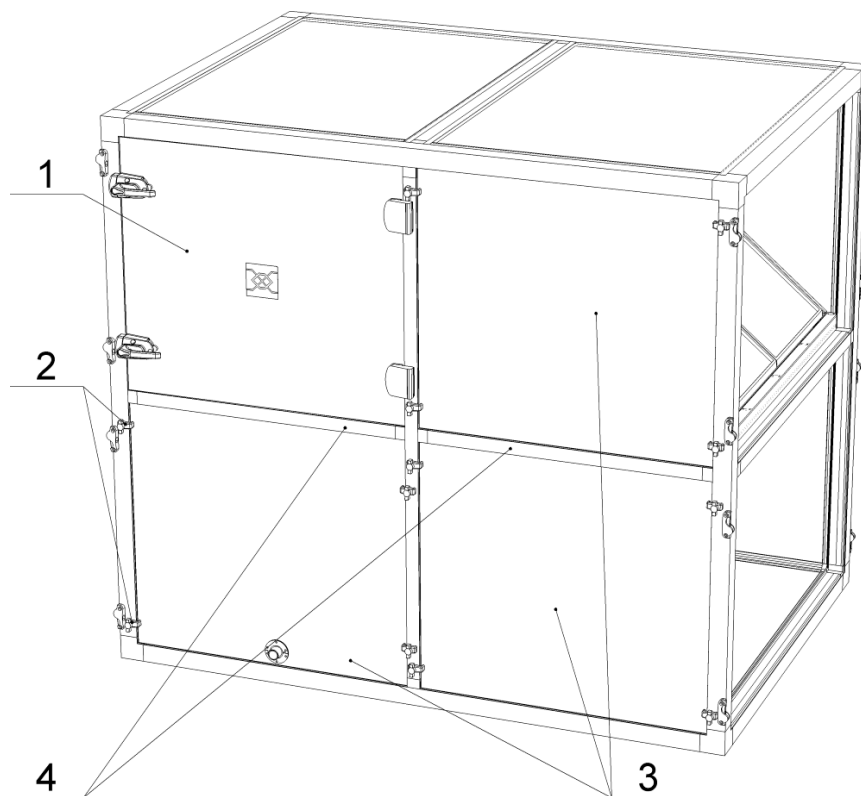

Figure 6.2.1.1 - Counter-flow heat exchanger section.

1 – Service door, 2 – panel blocks, 3 – removable panels, 4 – aluminium profiles.

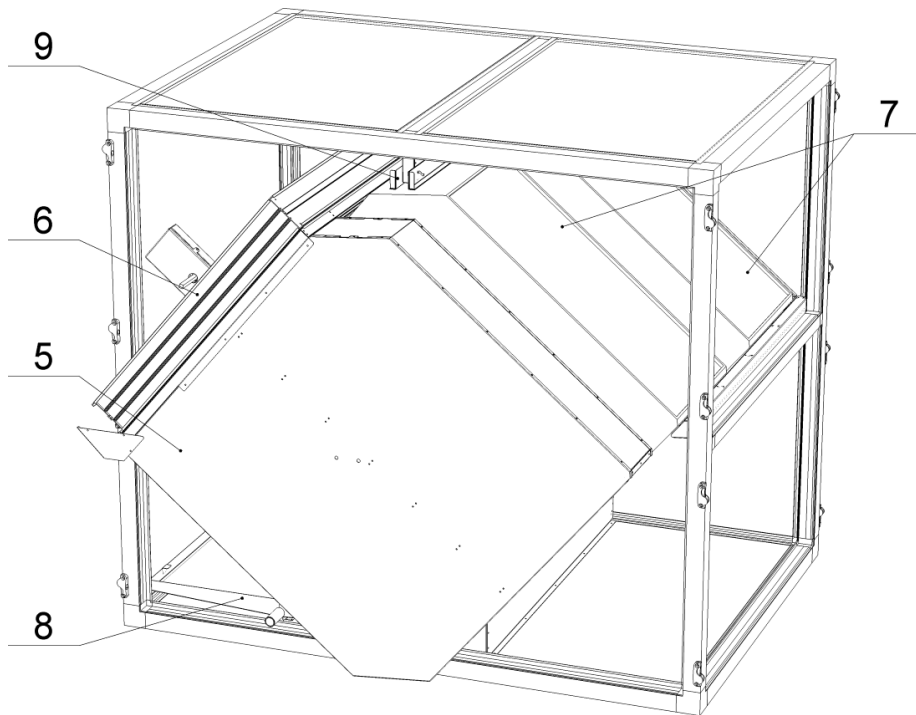

Figure 6.2.1.2 - Counter-flow heat exchanger section.

5 – By-pass chamber, 6 – by-pass damper, 7 – heat exchanger, 8 – condensate tray, 9 – quick-release mechanism.

## 6.2.2. Cross-flow plate heat exchanger

### Description:

In the plate heat exchanger, the warm extract air and the cool fresh air, separated by thin plates, pass each other in cross-flow. No mixing of the two air streams takes place. Therefore, the transmission of dirt, odours, moisture, bacteria, etc. is impossible. Heat transmitted from extract air to fresh air purely by conduction because of the temperature difference between the two air streams: the warm extract air cooled down and the cool fresh air heated up.

Cross-flow heat exchanger section divided in separate parts from size 12-KR (double deck) or 4-KR (side by side) due transportation reasons. Refer to separate assembly manual for assembly of such section.

### Types:

1. Crossflow plate heat exchanger double deck;
2. Crossflow plate heat exchanger side by side.

### Standard plate heat exchangers assembly components:

1. Aluminium plate heat exchanger;
2. Stainless steel drip tray on extract air side;
3. By-pass damper for performance control and freezing prevention.

### Optional components:

1. Epoxy coated plate heat exchanger;

2. Droplet eliminator (stainless steel frame, plastic profile) on extract air side;
3. Stainless steel drip tray on supply air side.

#### Electrical connection:

1. Electrical connection may only be undertaken by technically trained personnel.
2. Refer to separate "Electrical installation, operation and maintenance manual" for by-pass valve actuator connection.

#### Maintenance:

1. Check if gaps between the heat exchangers plates are not contaminated. Clean if necessary.
2. Check the drainage system (see 6.2.6. Drainage system).
3. Regular check if drip tray is tight. Clean drip train and drain piping.
4. Check if bypass damper works properly.
5. Check if the heat exchanger's sealing elements are not harmed (sealant, sealant strips). Repair if necessary.

#### Cleaning:

1. Cleaning sequence when the heat exchanger is in section:
  - Clean dust with soft brush;
  - Blow out dirt with the blower.
2. Cleaning sequence when heat exchanger is pulled out:
  - The heat exchanger is cleaned with tepid water and alkaline mixture which makes no corrosion to aluminium;
  - Do not use direct water flow or water blowers. It can spoil heat exchanger.
  - Put the heat exchanger back after cleaning.
  - Seal it hermetically; otherwise, the heat exchanger will not work properly!

#### Dismantling:

1. Release panel blocks 4;
2. Take off service door 1, panels 2 and aluminium profiles 3;
3. Release fixing bolts 9;
4. The heat exchanger 5 is pulled out together with bypass damper 6 and by-pass chamber 7;
5. Do not damage sealing strips while withdrawing the heat exchanger. If sealing strips are damaged change them with new ones;
6. Unscrew screws to unfasten the by-pass damper 6.
7. The heat exchanger is mounted conversely to dismantlement sequence.
8. Be sure that the heat exchanger installed hermetically.

#### Important:

1. Do not damage the heat exchanger's plates while mounting it into section.
2. Do not use the heat exchanger without filter in air handling unit! Filter must be installed before heat exchanger both in supply and in exhaust airflow.

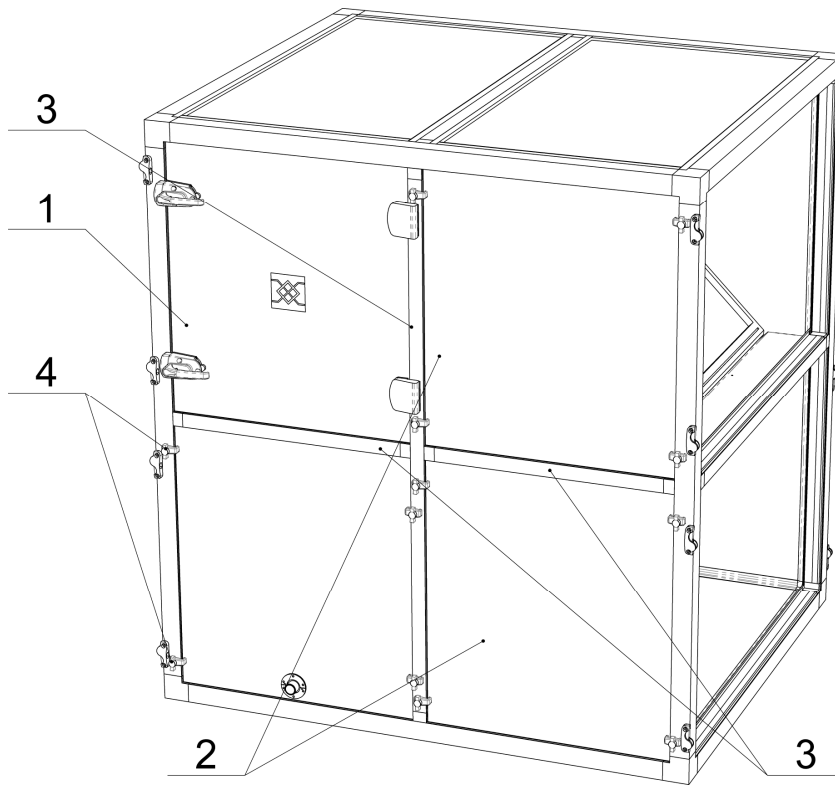

Figure 6.2.2.1 - Cross-flow heat exchanger section.

1 – Service door, 2 – removable panels, 3 – aluminium profiles, 4 – panel blocks.

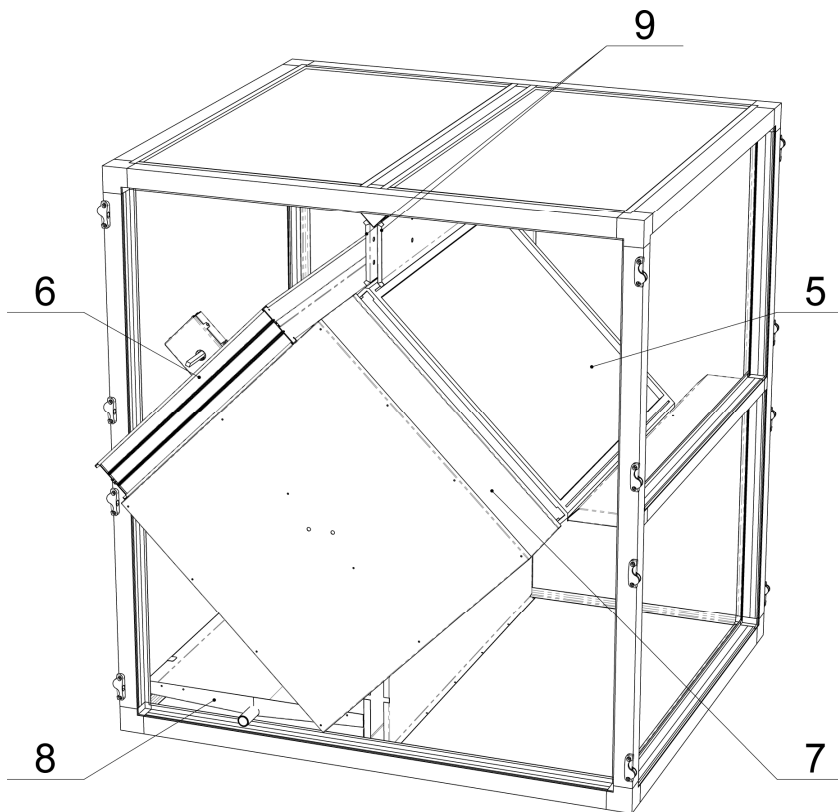

Figure 6.2.2.2 - Cross-flow heat exchanger section.

5 – Heat exchanger, 6 – by-pass damper, 7 – by-pass chamber, 8 – condensate tray, 9 – fixing bolts.

### 6.2.3. Rotary heat exchanger

#### Description:

Rotary heat exchangers are regenerators with rotating heat accumulators. The heat-dissipating and heat-absorbing air flows heat or cool the rotating, air-permeable storage accumulator. Depending on the air conditions and the surface of the accumulator material, moisture may also be transferred in the process. Self-cleaning effect due counter-flow supply. Double deck arrangement.

Rotary heat exchanger section can be divided in separate parts from size 12-KR (double deck) or 11-KR (side by side) due transportation reasons. Refer to separate assembly manual for assembly of such section.

Rotary heat exchanger itself divided in separate parts from wheel diameter 2690mm. Refer to separate assembly manual for assembly of such heat exchanger.

#### Types:

1. Rotary heat exchanger double deck;
2. Rotary heat exchanger side by side.

#### Material types:

1. Condensation - cost-efficient solution to recover sensible heat;
2. Condensation, epoxy coating – solution to recover sensible heat for applications with request of increased corrosion resistance;
3. Condensation, aluminium alloy 5052 - solution to recover sensible heat for industrial applications with request of increased corrosion resistance;
4. Enthalpy, hybrid - cost-efficient solution to recover sensible heat and transfer latent heat;
5. Sorption (molecular sieve 3Å) - solution to recover sensible heat and latent heat to a very high degree.

#### Electrical connection:

1. Electrical connection may only be undertaken by technically trained personnel.
2. Rotors equipped with 1-phase motor (w/o control), 3-phase motor (w/o control) or stepping motor with controller.
3. Refer to separate “Electrical installation, operation and maintenance manual” document for motor and controller connection.
4. Do not route the wires through the heat exchanger’s casing. Otherwise it will be impossible to pull out heat exchanger in case the maintenance needed without help of electrician.

#### Maintenance:

1. Check if the heat exchangers gaps are not contaminated. Clean if necessary.
2. Check if sealing brushes of the rotary heat exchanger work properly. Readjust or replace if necessary. The brush sealing are easily adjusted by loosening the screws and moving the brush sealing into the right position.
3. Check if driving gear of the rotary heat exchanger works properly.
4. Check if the heat exchanger's sealing elements are not harmed (sealant, sealing strips). Repair if necessary.

Cleaning:

1. Cleaning sequence when heat exchanger is in section:
  - Clean dust with soft brush;
  - Dirt can be cleaned out with blower slowly turning the rotor.
2. Cleaning sequence when heat exchanger is pulled out:
  - Heat exchanger is cleaned with tepid water and alkaline mixture which makes no corrosion to aluminium;
  - Do not use direct water flow or water blowers. It can spoil heat exchanger.
  - Put the heat exchanger back after cleaning.
  - Seal it hermetically; otherwise, the heat exchanger will not work properly!

Dismantling:

1. Release panel blocks 1.
2. Take off panel 2.
3. Unscrew screws and disengage fastening elements 3.
4. Take out rotary heat exchanger with casing 4.
5. Take off driving gear, unscrew axis and fastening bolts in case of rotary heat exchanger 5 extraction.
6. The heat exchanger is mounted conversely to dismantlement sequence.
7. Be sure that the heat exchanger is installed hermetically.

Important:

1. Some rotary heat exchangers are delivered with rubber transportation locks 6 which prevent rotor wheel from deformation. These rotary heat exchangers are marked with special warning label on the section. Remove rubber transportation locks before connecting rotary heat exchanger section to other section of the AHU otherwise the unit will not work properly.
2. Do not damage the heat exchanger's foil while mounting it into section.
3. Do not use the heat exchanger without filter in air handling unit! Filter must be installed before heat exchanger both in supply and in exhaust airflow.

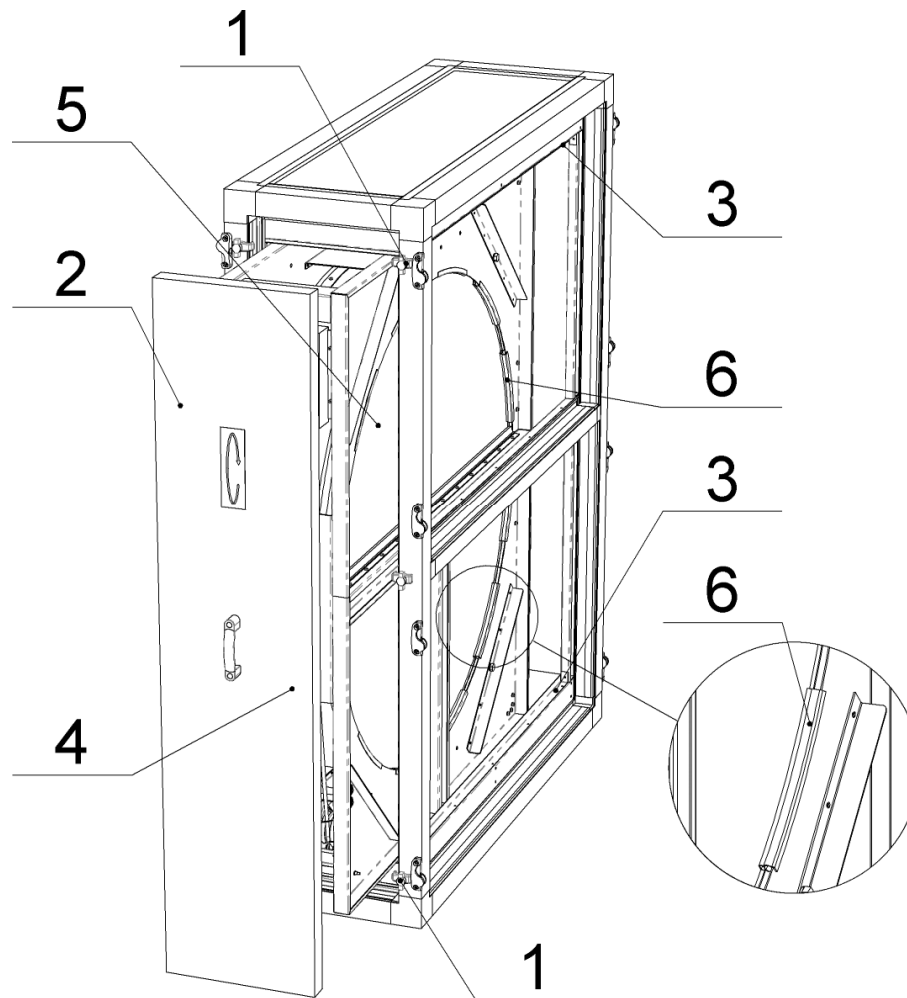

Figure 6.2.3.1 - Rotary heat exchanger section.

1 – Panel blocks, 2 – removable panel, 3 – fastening elements, 4 – casing, 5 – rotary heat exchanger, 6 - rubber transportation locks.

#### 6.2.4. Run around coils

##### Description:

Run around coils system consists of one or several supply air and extract air coils in which a brine solution circulated to recover heat energy from the extract air. The airflows not mixed, so there is no contamination of the fresh air by the exhaust airflow.

##### Technical data:

1. Normal air velocity 2-3m/s. Max air velocity 5.0 m/s.
2. Max permissible operating pressure: 1.6 MPa at a max permissible operating temperature of 100°C.
3. Max permissible operating pressure: 1.0 MPa at a max permissible operating temperature of 150°C.
4. The coils consist of copper tubes and aluminium, AlMg 2.5 or epoxy coated aluminium fins. The casing is made of hot galvanized steel sheet, AluZn 185 steel sheet, aluminium, AISI 304 or AISI 316.



5. The coil header can be equipped with nipples for bleeding and draining (depends on coil supplier) and at least one of the nipples can be equipped with extension nipple for a freeze protection thermostat (see Figure 6.3.1.4 and Figure 6.3.1.5).
6. Extension nipple does not available for water connection size DN 15.
7. Extract air coil with stainless steel drip tray and droplet eliminator (stainless steel frame, plastic profile). Droplet eliminator always included if air speed through coils from 2,5m/s (aluminium fins) or from 1,6m/s (epoxy coated fins). Optional for lower speeds.
8. All the connections are fitted with male pipe threads (SS-EN ISO 228-1).
9. Coils sections provided without circulation pump and mixing valve. Refer to pump provider documentation for pump connection.

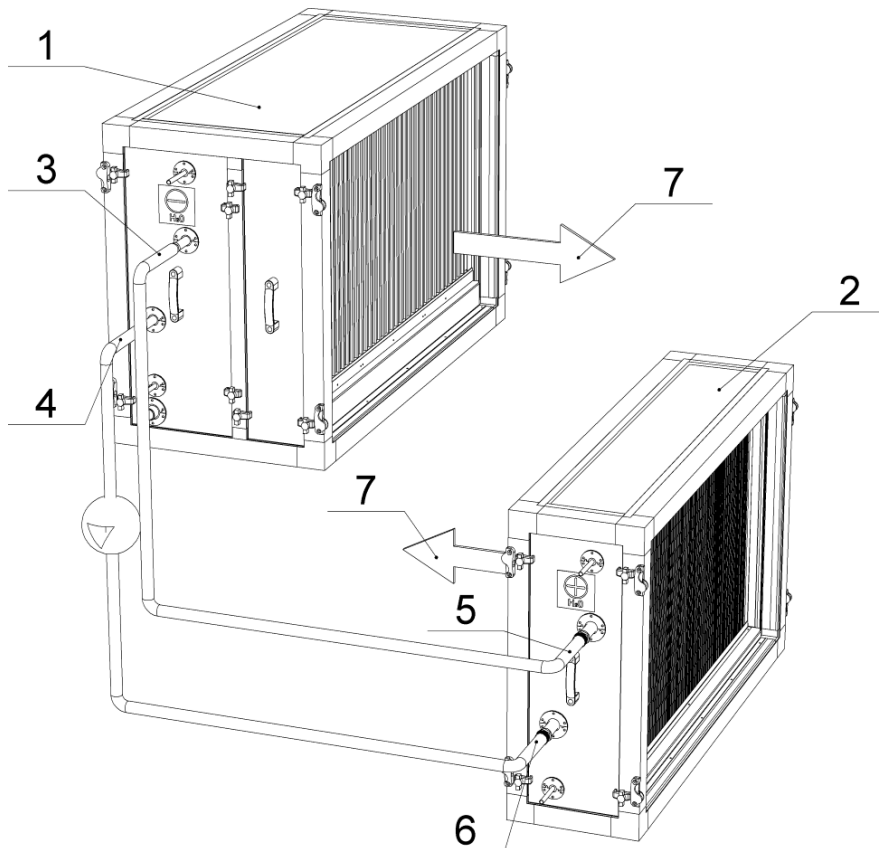

Figure 6.2.4.1 - Run around coils section.

1 – Extract air coil section; 2 – supply air coil section; 3, 6 – liquid inlet; 4, 5 – liquid outlet, 7 – airflow direction.

Maintenance and cleaning, dismantling:

Refer to section “6.3.1. Water heater” for supply air coil.

Refer to section “6.3.2. Water cooler” for extract air coil.



### 6.2.5. Rotary heat exchanger with heat pump section

#### Description:

Rotary heat exchanger with heat pump is a separate section, containing complete stand-alone reversible heat pump system (heating and cooling). The refrigerant is evaporated and condensed directly in the integrated batteries and the capacity controlled automatically.

Rotary heat exchanger with heat pump section for big sizes of air handling unit could be divided in separate parts. Refer to separate assembly manual for assembly of such section.

#### Technical data:

Refer to separate “Rotary heat exchanger with heat pump installation, operation and maintenance manual”.

#### Maintenance and cleaning, dismantling:

Refer to section “6.2.3. Rotary heat exchanger” for rotary heat exchanger.

Refer to section “6.3.3. DX cooler” for coils.

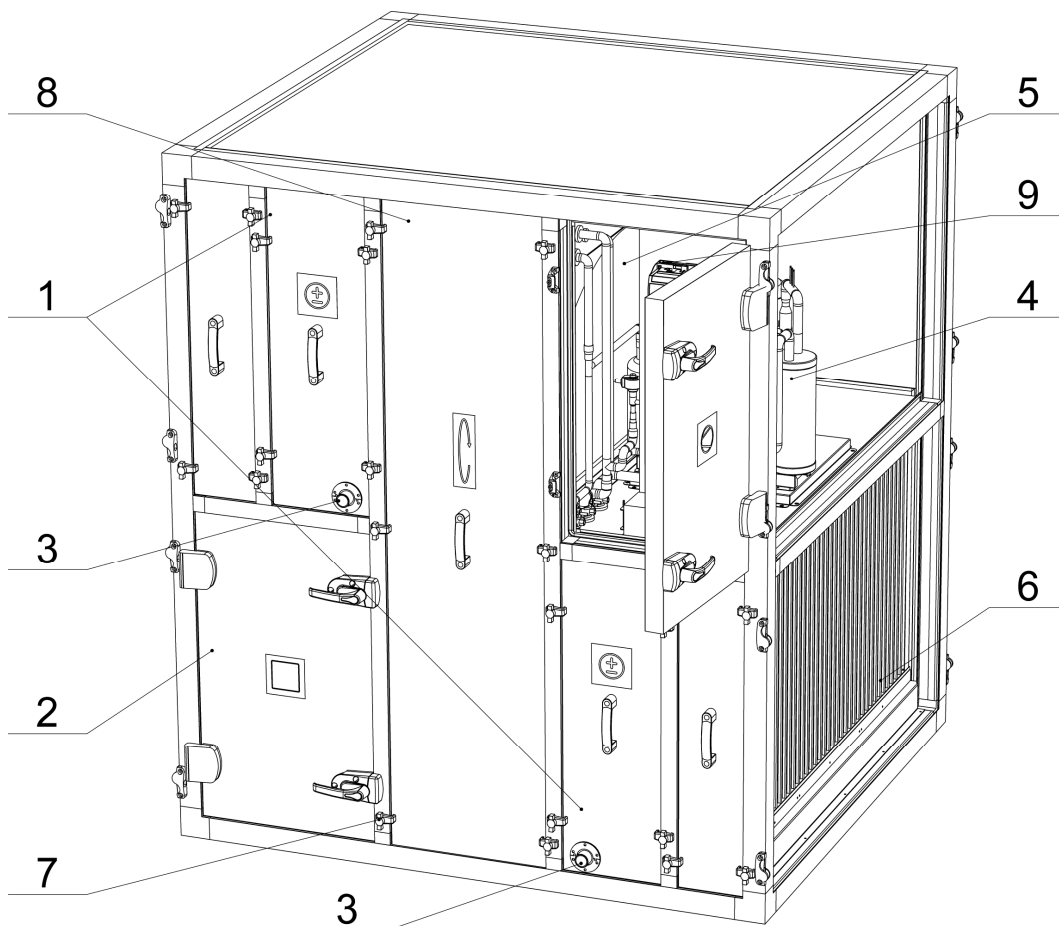

Figure 6.2.5.1 - Rotary heat exchanger with heat pump section.

1 – removable panel of DX cooler/heater section, 2 – service door of empty section, 3 – condensate tray, 4 – heat pump, 5 – rotary heat exchanger, 6 – droplet eliminator, 7 – panel blocks, 8 – removable panel of rotary heat exchanger section, 9 – controls.

## 6.2.6. Drainage system

### Description:

When plate heat exchangers or coolers are used in ventilation system the drainage system must be mounted. Drainage system consists of drip trays (mounted into air handling unit), siphons, pipes, valves.

### Construction and requirements to siphon:

Siphon is the main element in the system. It can be made from metal, plastic. Siphon must be made from corrosion resistant material. It is desirable that siphon should be made from transparent material (it is the best way to see if siphon is filled with water or not).

The height of the syphon must be set in accordance with the under pressure or overpressure of ventilation unit so that suction or blowing out of the air in relation to connected waste water pipe is prevented. The water must flow directly from the syphon into a catch pit or funnel. Inner radius of siphon must be the same size as drainage connection tube's (drainage outlet tube of drip tray).

Drip trays equipped with pipes Ø40mm.

### Calculation of siphon trap (see Figure 6.2.6.1):

The height of the siphon is determined as follows:

1. Under (negative) pressure in the section:

$$H \text{ (mm)} = \frac{p}{10} + 85, \text{ mm}$$

Where  $p$  = pressure in the section in Pa (positive value). In case  $p < 500$  Pa use 500 Pa for calculation.

2. Over pressure (positive) in the section:

$$H \text{ (mm)} = \frac{1.5 \cdot p}{10} + 115, \text{ mm}$$

Where  $p$  = pressure in the section in Pa. In case  $p < 500$  Pa use 500 Pa for calculation.

3. A clear space of at least  $X_{\min} = H - 85$ , mm is required below the bottom of the unit section for the water trap.

### Important:

1. Siphon and pipes must be heated with an electric thermal cable for outdoor units (this will prevent freezing of drainage system at negative ambient temperatures). Additionally siphon and pipes should be thermal insulated with an insulating material.
2. Fill siphon with water before start-up of the unit.

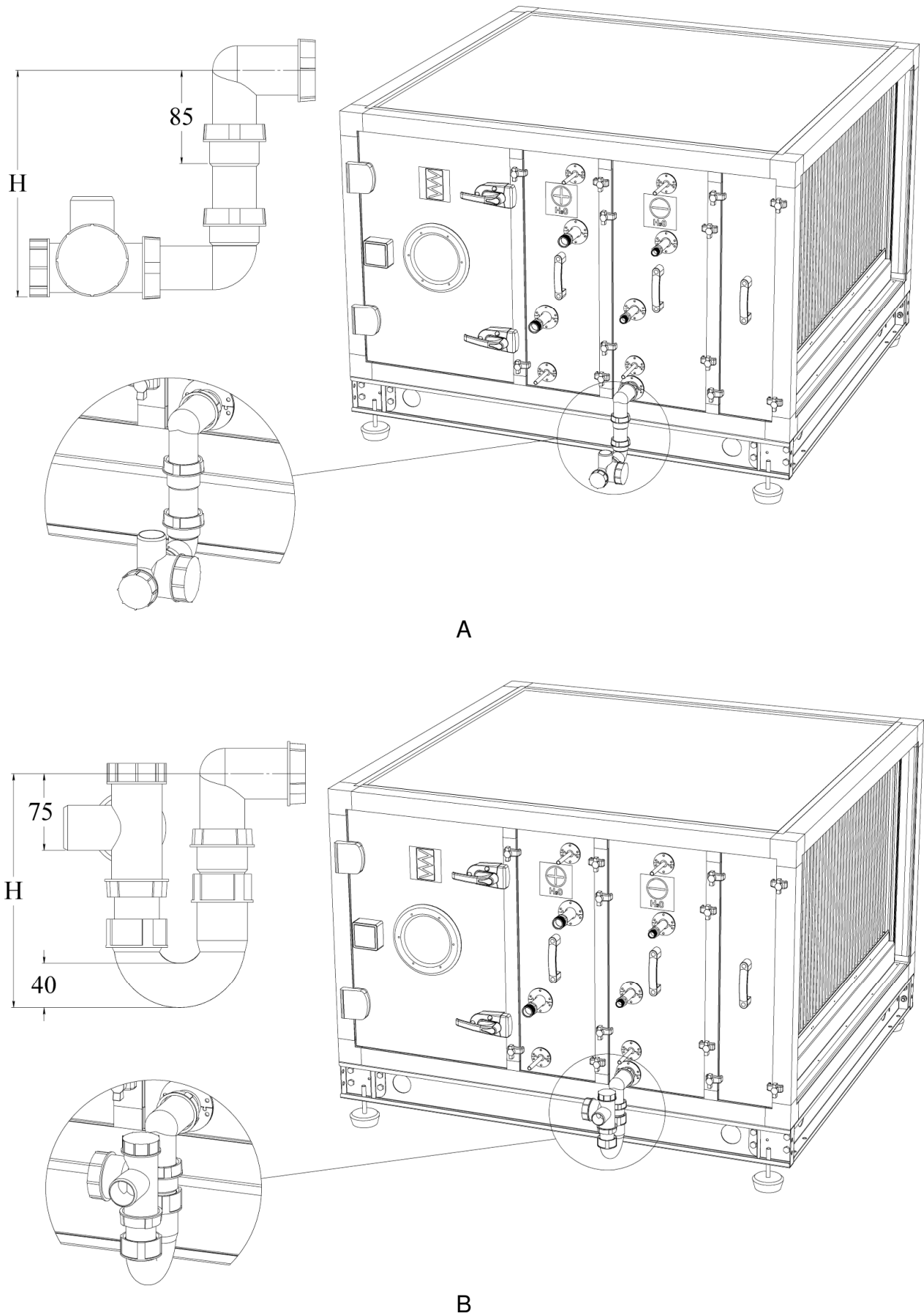

Figure 6.2.6.1 - Height of syphon trap.

A - Height of ball syphon for negative pressure, B – height of syphon for positive pressure.

#### Construction and requirements to drainage system:

The air handling unit may have different number of drip trays. It depends on its components. Sections with drip tray: plate heat exchanger section, water cooler section, DX cooler section, heat recovery coil's exhaust air section. The main requirement to drainage system is that every drainage connection tube (drainage outlet tube of drip tray) should be connected to separate siphons. Do not install positive or negative pressure siphon trap to the same drain pipe. Do not under any circumstances connect the syphon directly to the sewage network. Drain pipes shall have a slope of at least 2<sup>0</sup> towards the drain.

To avoid flowing of water from one unit's side to other side (because of pressure difference) mount tubes of equal diameters, ensure that drainage system is mounted tightly and diameter of connection tubes should be of the same diameter as drainage connection tubes (drainage outlet tube of drip tray). Siphons must be always filled with water. If siphon is not filled with water it cannot carry out its function and premises can be dousing with water. Check tightness of drainage system each 3 months.

#### Important:

The water trap and discharge pipe must not be subjected to temperatures below freezing. If the unit is installed outdoors, the drain pipe, water trap and discharge pipe must be insulated. The water trap should not be exposed to direct sunlight.

### 6.2.7. Plate heat exchanger with heat pump section

#### Description:

Plate heat exchanger (cross-flow or counter-flow) with heat pump is a separate section, containing complete stand-alone heat pump system (heating). The refrigerant is evaporated and condensed directly in the integrated batteries and the capacity controlled automatically. This section can be selected for AmberAir Pool air handling units.

Plate heat exchanger with heat pump section for big sizes of air handling unit could be divided in separate parts. Refer to separate assembly manual for assembly of such section.

#### Technical data:

Refer to separate "AmberAir Pool IOM".

#### Maintenance and cleaning, dismantling:

Refer to section "6.2.1. Counter-flow plate heat exchanger" for counter-flow plate heat exchanger.

Refer to section "6.2.2. Cross-flow plate heat exchanger" for cross-flow plate heat exchanger.

Refer to section "6.3.3. DX cooler" for coils.

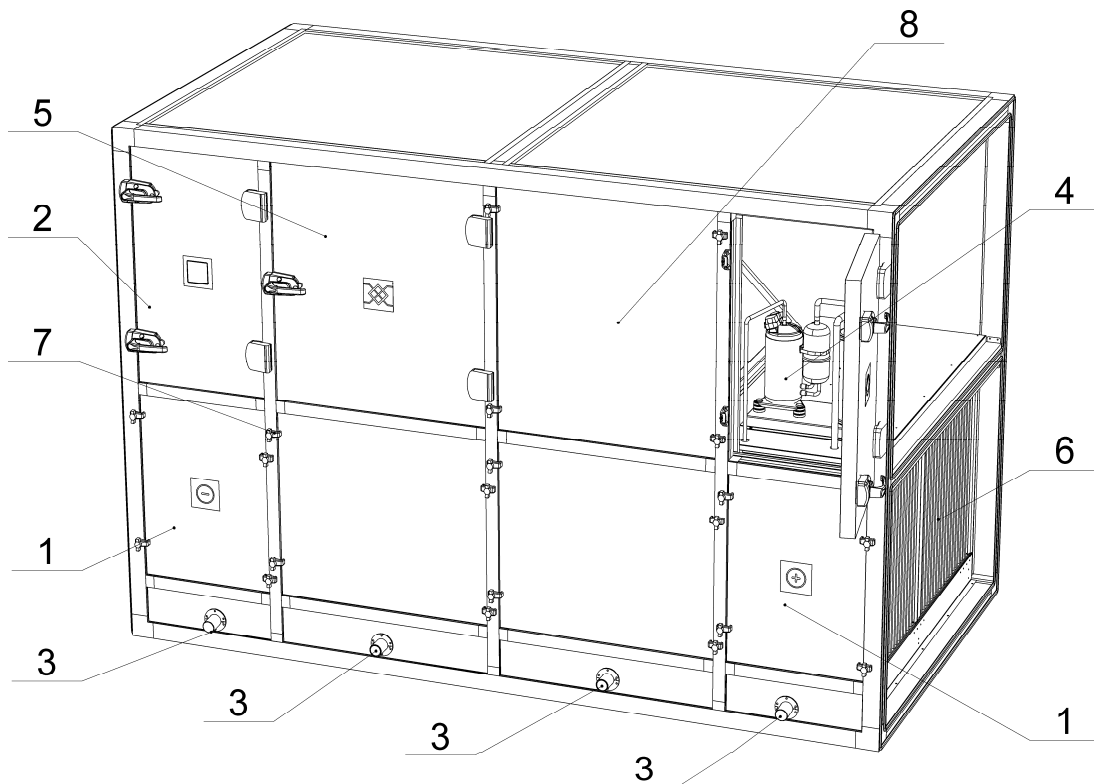

Figure 6.2.7.1 - Plate heat exchanger with heat pump section.

1 – Removable panel of DX cooler/heater section, 2 – service door of empty section, 3 – condensate tray, 4 – heat pump, 5 – service door of plate heat exchanger, 6 – droplet eliminator, 7 – panel blocks, 8 – removable panel of plate heat exchanger section.

## 6.2.8. Cross-Flow section

### Description:

Cross-flow section is used to change air flow directions before or after cross-flow, counter-flow and rotary heat exchanger.

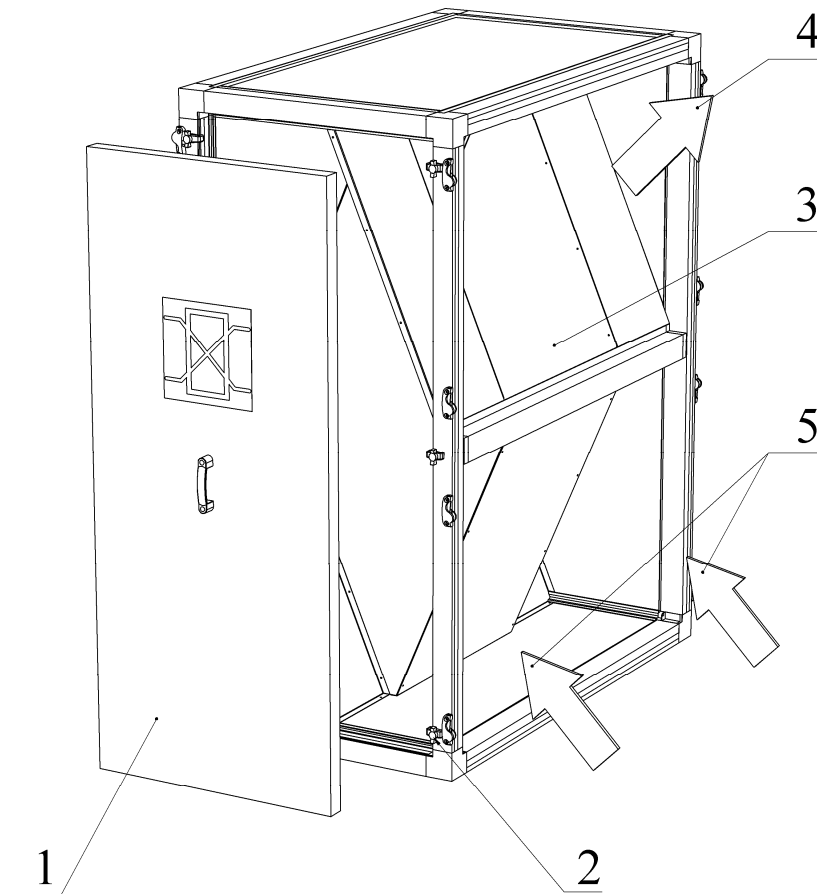

1 – Removable panel, 2 – panel blocks, 3 – airflow guide, 4, 5 – airflow direction.

## 6.3. Heat exchangers

### 6.3.1. Water heater

#### Description:

The water heaters designed for heating air with fluid as the heat carrier and mounted in the unit.

#### Technical data:

1. Normal air velocity 2-4m/s. Max permissible air velocity 5m/s.
2. Max permissible operating pressure: 1.6MPa at a max permissible operating temperature of 100°C.
3. Max permissible operating pressure: 1.0MPa at a max permissible operating temperature of 150°C.
4. The coil consist of copper tubes and aluminium or epoxy coated aluminium fins. The casing is made of hot galvanized steel sheet or AluZn 185 steel sheet. Other materials on request.
5. The coil header can be equipped with nipples for bleeding and draining (depends on heater supplier) and at least one of the nipples can be equipped with extension nipple for a freeze protection thermostat (see Figure 6.3.1.4 and Figure 6.3.1.5).
6. Extension nipple does not available for water connection size DN 15.
7. All the connections are fitted with male pipe threads (SS-EN ISO 228-1).

8. Water heater sections can be supplied with heat carrier temperature control point RMG. Refer to separate “Electrical installation, operation and maintenance manual” document for RMG connection.

#### Maintenance and cleaning:

1. Regularly check if the heater is not contaminated or spoiled.
2. The system must be adequately vented to provide correct performance. To remove air from the water heater use air bleed nipple 2. Optional manual bleed valve or automatic bleed valve available on request (see Figure 6.3.1.4 and Figure 6.3.1.5). Bleed valve can be connected to nipple for bleeding or directly to main liquid tube (depends on heater supplier).
3. Water connection system must be tight.
4. If heater is contaminated, clean it with brush, vacuum cleaner or with direct air stream. In more difficult situation, clean grime using tepid water and alkaline mixture, which does not generate corrosion to aluminium.
5. If the heating surfaces coated with greasy dust, first spray the entire heater with environmentally compatible solvent under low pressure. Then clean the heater with water using a high-pressure jet after 10-12 minutes. It is important to hold the nozzle perpendicular to the fins and not closer than 150mm to prevent damaging the fins. Use a fin comb to straighten any deformed fins.
6. When installing air heaters that use hot water or steam as a heating medium, great care should be exercised when opening air vents and gate valves in the system. Failure to do this may result in serious damage through water hammering or a discharge of steam.
7. To avoid burns, do not touch hot surfaces.

#### Dismantling:

1. Whenever a heater is to be dismantled and removed from a system, it is important that the heater be emptied of liquid (use liquid drain pipe 3).
2. If freezing is likely to occur in the heater after it has been drained of liquid, it should be blown with compressed air to ensure that all water is gone.
3. Release panel blocks 4.
4. Take off panel 5 together with sealing ring's covers 9 and sealing rings 6 itself.
5. Unscrew screws and disengage fastening elements 7 presented at the bottom and at the top.
6. Take out the heater 8.
7. The water heater mounted conversely to dismantlement sequence.
8. Ensure tightness between heater casing and frame construction, tubes and protection cover after mounting.
9. Protect connection tubes and aluminium fins from deformation while mounting heater into the air handling unit.
10. Make sure that airflow does not get into header of coil when heater is mounted.

#### Important:

1. If chloride content of process water is above 120-ppm (120mg/l) supplier is not responsible for corrosion occurred in such conditions.
2. The coils shall be connected to obtain a counter-flow mode, i.e. air and water must flow against each other, see Figure 6.3.1.2 and Figure 6.3.1.3. Section provided with labels that indicate how the inlet and the return piping is to be connected.



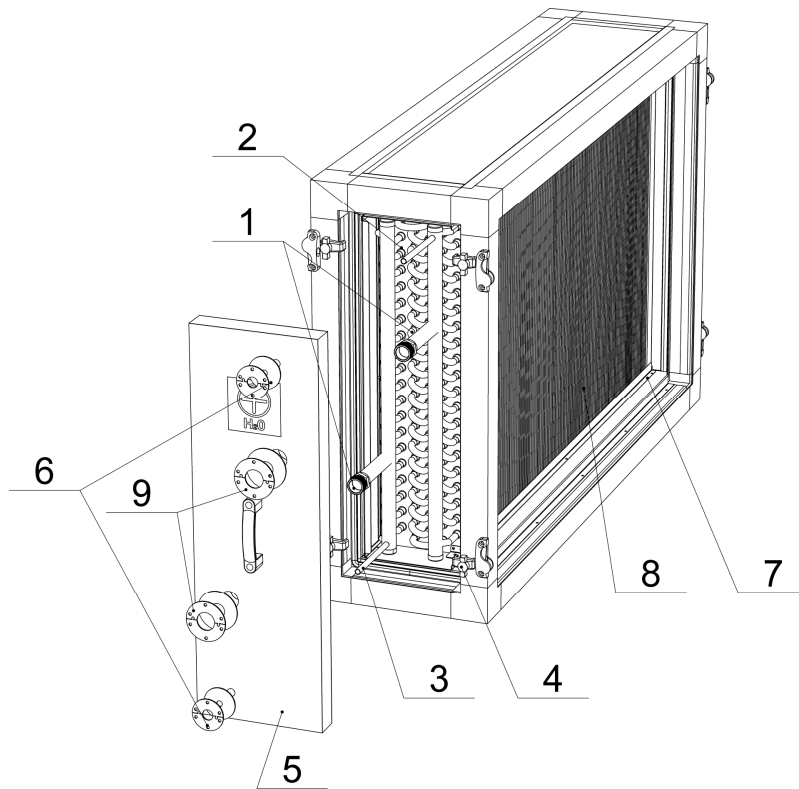

Figure 6.3.1.1 - Water heater section.

1 – Water inlet/outlet, 2 – nipple for bleeding, 3 – nipple for draining, 4 – panel blocks, 5 – removable panel, 6 – sealing ring, 7 – fastening element, 8 – heating coil, 9 – sealing ring's cover.

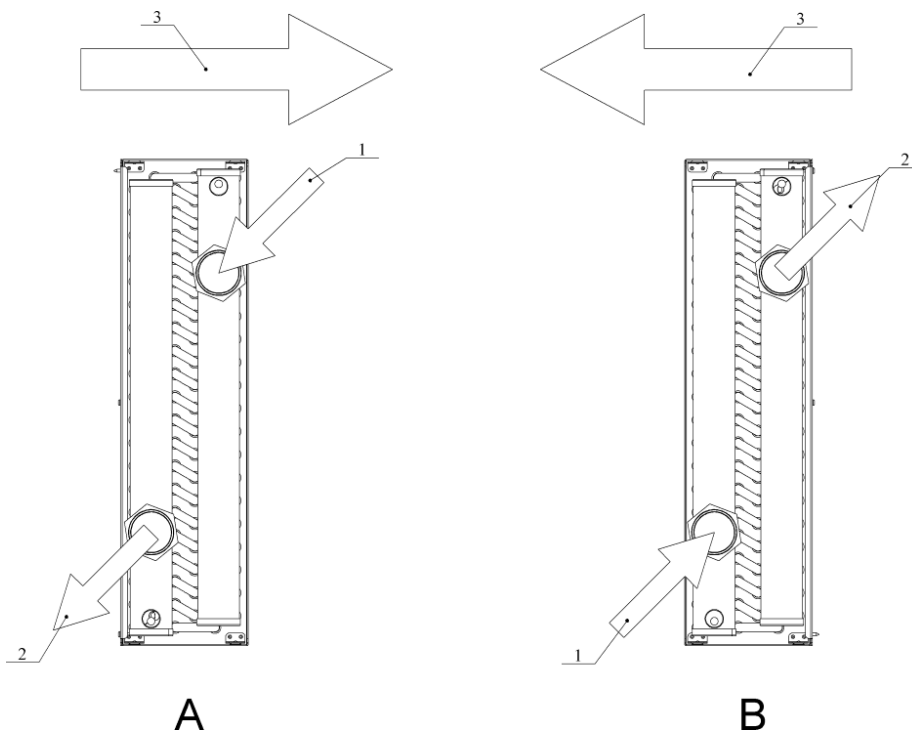

Figure 6.3.1.2 - Coil counter-flow coupling (single liquid inlet and outlet).

A – Right-hand maintenance; B – left-hand maintenance; 1 – liquid in; 2 – liquid out; 3 – airflow direction.



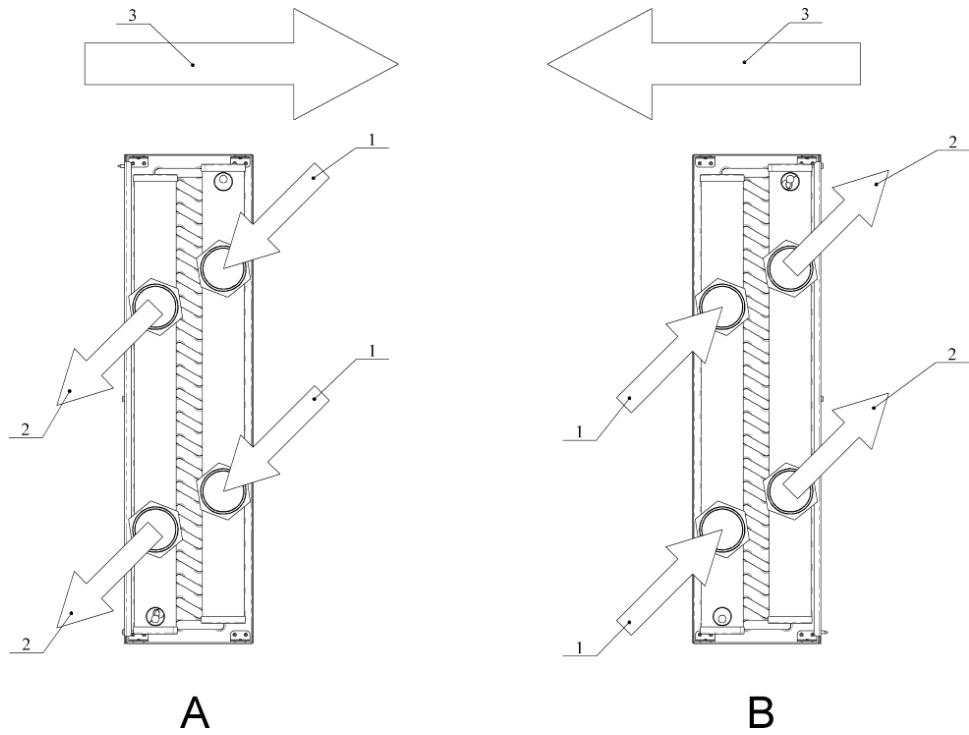
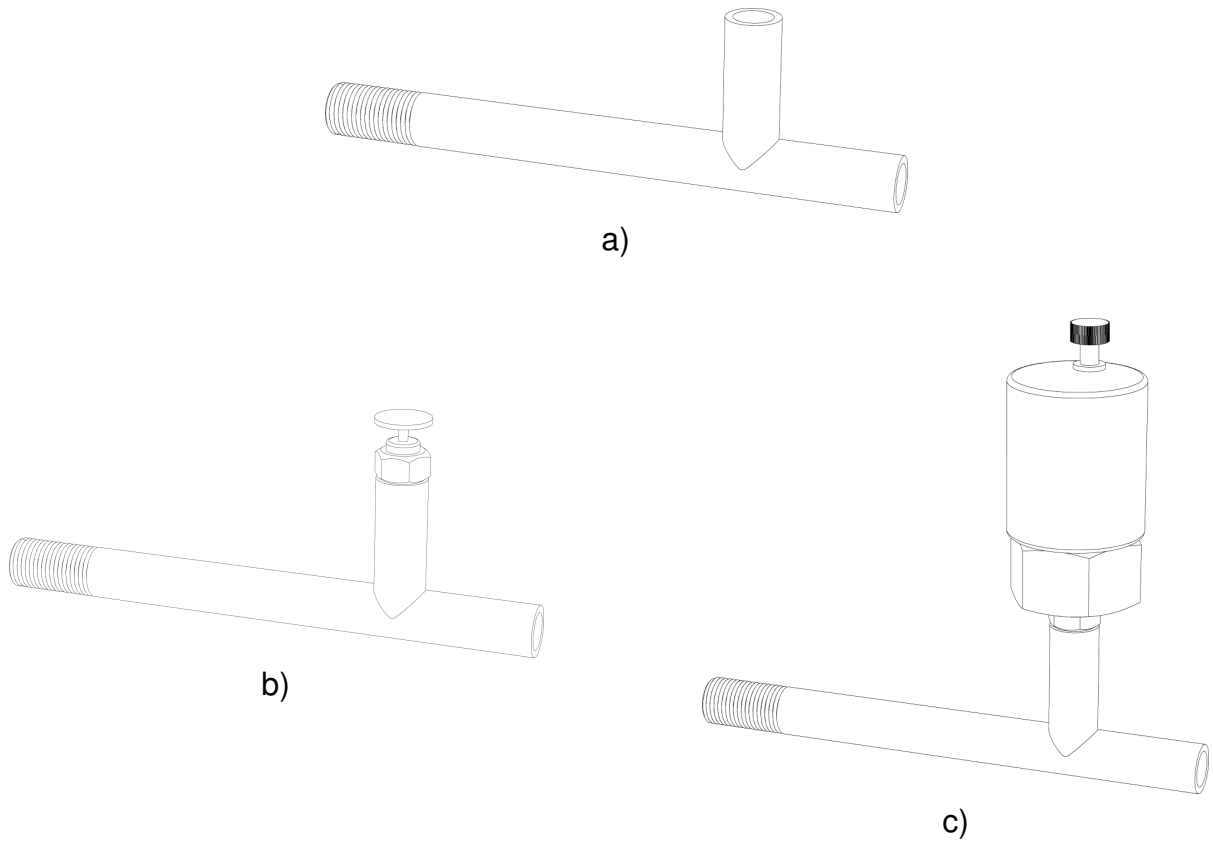

Figure 6.3.1.3 - Coil counter-flow coupling (multiple liquid inlets and outlets).  
 A – Right-hand maintenance; B – left-hand maintenance; 1 – liquid in; 2 – liquid out; 3 – airflow direction.



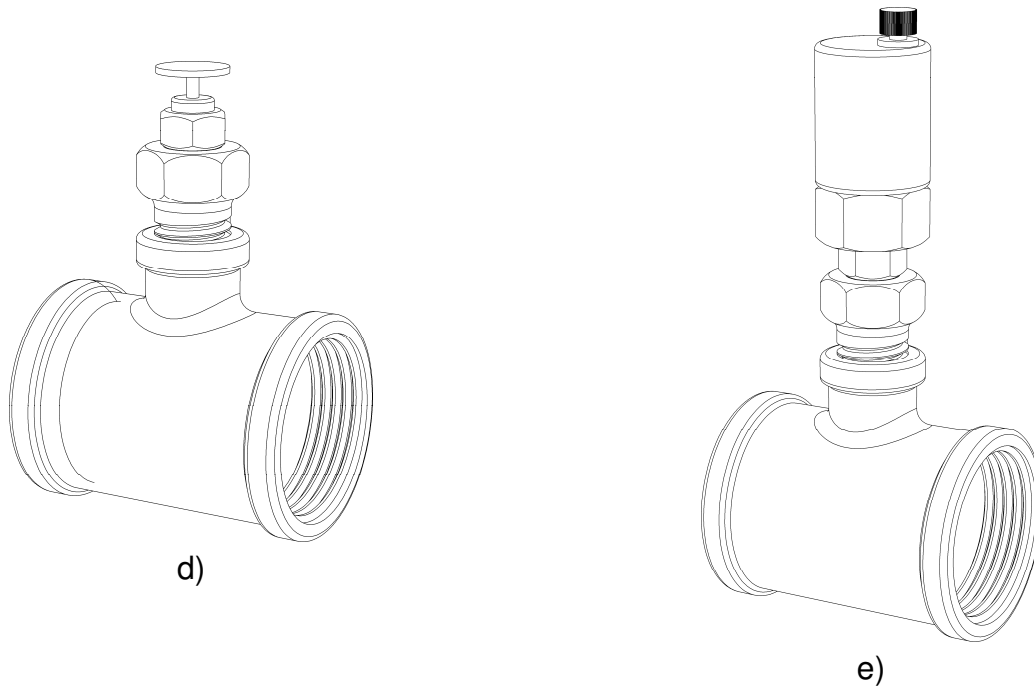

Figure 6.3.1.4 - Water coils accessories.

a – nipple H-A01, b – manual bleed valve H-A02, c – automatic bleed valve with non-return valve H-A03, d – manual bleed valve H-A04 (direct connection to main liquid tube), e – automatic bleed valve with non-return valve H-A05 (direct connection to main liquid tube).

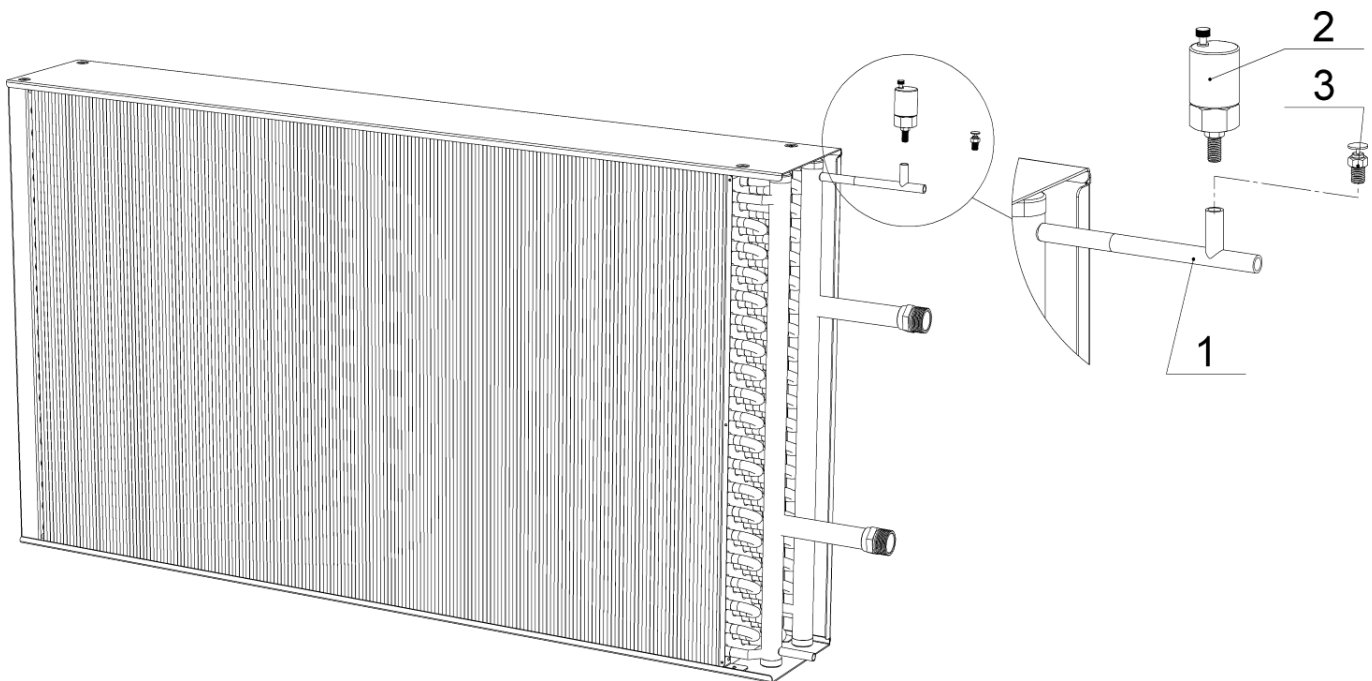

Figure 6.3.1.5 - Bleed valve and nipple installation.

1 – Nipple for bleeding, 2 – Automatic bleed valve with non-return valve, 3 – Manual bleed valve.

### 6.3.2. Water cooler

#### Description:

The water cooler designed for cooling air with fluid as the heat carrier and mounted in the unit.

#### Technical data:

1. Normal air velocity 2-3m/s. Max permissible air velocity 5m/s.
2. Max permissible operating pressure: 1.6MPa at a max permissible operating temperature of 100°C.
3. Max permissible operating pressure: 1MPa at a max permissible operating temperature of 150°C.
4. The coil consist of copper tubes and aluminium or epoxy coated aluminium. The casing is made of hot galvanized steel sheet or AluZn 185 steel sheet. Other materials on request.
5. The coil header can be equipped with nipples for bleeding and draining (depends on cooler supplier) and at least one of the nipples can be equipped with extension nipple for a freeze protection thermostat (see Figure 6.3.1.4 and Figure 6.3.1.5).
6. Extension nipple does not available for water connection size DN 15.
7. All the connections are fitted with male pipe threads (SS-EN ISO 228-1).
8. Section supplied with stainless steel drip tray and droplet eliminator (stainless steel frame, plastic profile). Droplet eliminator always included if air speed through coils from 2,5m/s (aluminium fins) or from 1,6m/s (epoxy coated fins). Optional for lower speeds.
9. Water heater sections can be supplied with heat carrier temperature control point RMG. Refer to separate "Electrical installation, operation and maintenance manual" document for RMG connection.

#### Maintenance and cleaning:

1. Regularly check if cooler is not contaminated or spoiled.
2. The system must be adequately vented to provide correct performance. To remove air from the water cooler use the air bleed nipple 2. Optional manual bleed valve or automatic bleed valve available on request (see Figure 6.3.1.4 and Figure 6.3.1.5). Bleed valve can be connected to nipple for bleeding or directly to main liquid tube (depends on cooler supplier).
3. Water connection system must be tight.
4. Check the drainage system (see 6.2.6. Drainage system.).
5. Regularly check if drip tray 9 is tight. Clean drip train and drain piping.
6. If cooler is contaminated, clean it with brush, vacuum cleaner or with direct air stream. In more difficult situation, clean grime using tepid water and alkaline mixture, which does not generate corrosion to aluminium.
7. If the cooling surfaces coated with greasy dust, first spray the entire cooler with environmentally compatible solvent under low pressure. Then clean the cooler with water using a high-pressure jet after 10-12 minutes. It is important to hold the nozzle perpendicular to the fins and not closer than 150mm to prevent damaging the fins. Use a fin comb to straighten any deformed fins.
8. If droplet eliminator is contaminated, clean it.

### Dismantling:

1. Whenever a cooler is to be dismantled and removed from a system, it is important that the cooler be emptied of liquid (use liquid drain pipe 3).
2. If freezing is likely to occur in the cooler after it has been drained of liquid, it should be blown with compressed air to ensure that all water is gone.
3. Release panel blocks 4.
4. Take off panels 5 together with sealing ring's covers 11 and sealing rings 6 itself.
5. Unscrew screws and disengage fastening elements 7 presented at the bottom and at the top.
6. Take out the cooler 8 and droplet eliminator 10.
7. The water cooler is mounted conversely to dismantlement sequence.
8. Ensure tightness between cooler casing and frame construction, tubes and protection cover after mounting.
9. Protect connection tubes and aluminium fins from deformation while mounting cooler into the air handling unit.
10. Make sure that airflow does not get into header of coil when coil is mounted.

### Important:

1. If chloride content of process water is above 120-ppm (120mg/l) supplier is not responsible for corrosion occurred in such conditions.
2. The coils shall be connected to obtain a counter-flow mode, i.e. air and water must flow against each other, see Figure 6.3.1.2 and Figure 6.3.1.3. Section provided with labels that indicate how the inlet and the return piping is to be connected.

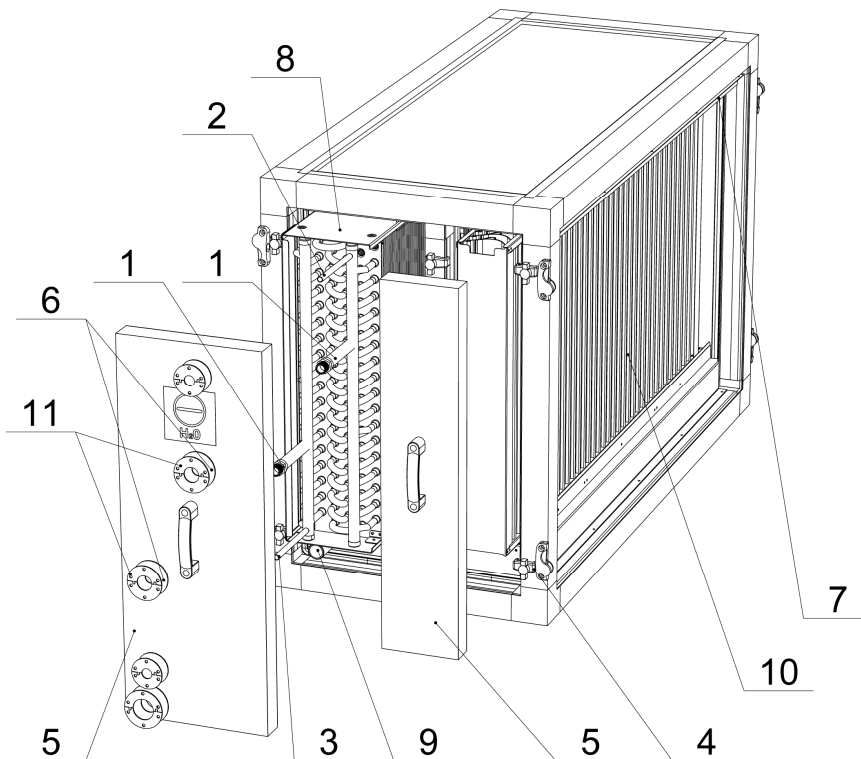

Figure 6.3.2.1 - Water cooler section.

1 – water inlet/outlet, 2 – nipple for bleeding, 3 – nipple for draining, 4 – panel blocks, 5 – removable panel, 6 – sealing ring, 7 – fastening element, 8 – cooling coil, 9 – drip tray, 10 – droplet eliminator, 11 – sealing ring's cover.

### 6.3.3. DX cooler

#### Description:

The DX cooler designed for cooling air with an evaporating medium and mounted in the unit.

#### Technical data:

1. Normal air velocity 2-3m/s. Max permissible air velocity 5m/s.
2. Depending on refrigerant type and evaporating temperature DX coolers available with max permissible operating pressure 2.2MPa, 2.9MPa or 4.3MPa at a max permissible operating temperature of 100°C. Do not exceed permissible pressure range.
3. The coil consist of copper tubes and aluminium or epoxy coated aluminium. The casing is made of hot galvanized steel sheet or AluZn 185 steel sheet. Other materials on request.
4. For utmost cleanness, the coils are inert gas soldered and filled with nitrogen prior to delivery.
5. Section with stainless steel drip tray and droplet eliminator (stainless steel frame, plastic profile). Droplet eliminator always included if air speed through coils from 2,5m/s (aluminium fins) or from 1,6m/s (epoxy coated fins). Optional for lower speeds.

#### Output stages:

DX coolers can be delivered divided into one, two or several output stages depending on the height of the heat exchanger.

First tube in airstream is always refrigerant "OUT" tube and the second tube is refrigerant "IN" tube for one stage cooler.

DX coolers with two output stages are normally coupled so that every other coil is coupled to output stage 1 and every other to output stage 2 ("interlaced coupling"), see Figure 6.3.3.1. Connections and fluid pipes are equipped with copper washers that indicate the stage association. DX coolers with three or more output stages are normally divided vertically, see Figure 6.3.3.2.

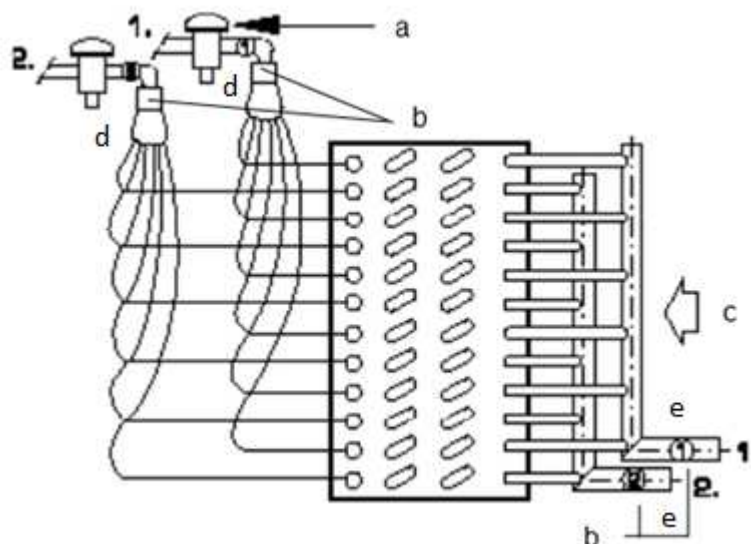

Figure 6.3.3.1 - Two output stages with "interlace coupling".

a – Expansion valve (not included), b – soldered copper washer, c – air direction, d – refrigerant IN, e – refrigerant OUT.

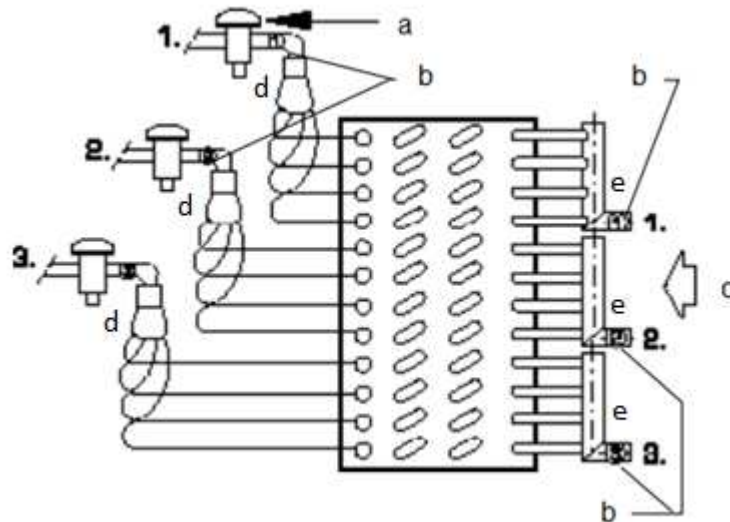

Figure 6.3.3.2 - Three or more output stages are normally divided vertically.  
 a – Expansion valve (not included), b – soldered copper washer, c – air direction.

Maintenance and cleaning:

Refer to section “6.3.2. Water cooler”.

Heating Mode:

DX cooler can work either in heating mode (optional checkbox in selection software). In this case used special three-pipe coil. Possible connection to system for cooling mode shown in Figure 6.3.3.3 and for heating mode shown in Figure 6.3.3.4.

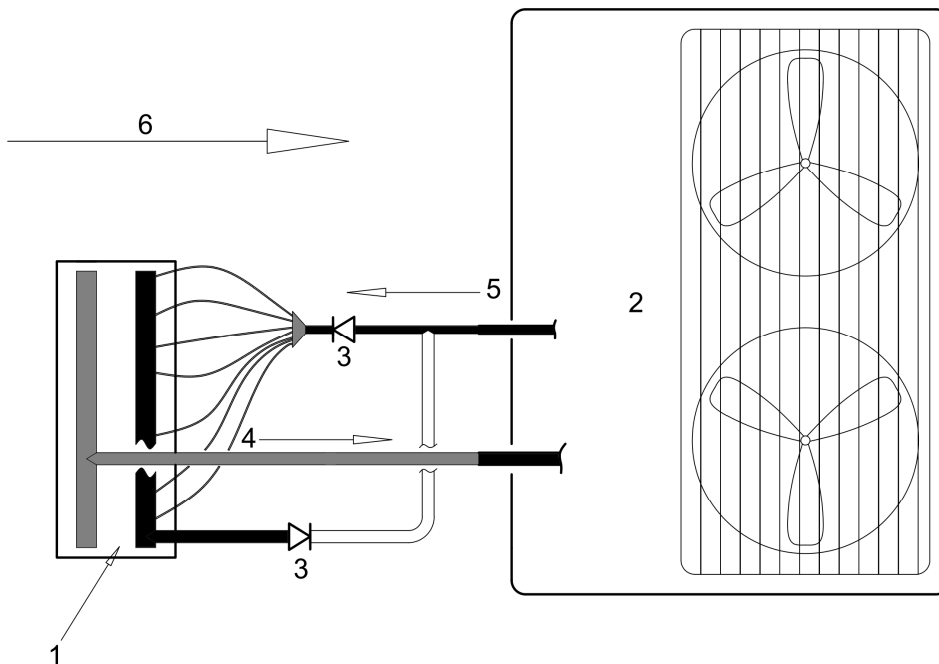

Figure 6.3.3.3 - Reversible refrigerant flow, three-pipe coil, cooling mode.

1 – Evaporator (cooling mode), 2 – outside unit, 3 – check valve, 4 – refrigerant flow (out of the coil), 5 – refrigerant flow (into the coil), 6 – airflow direction

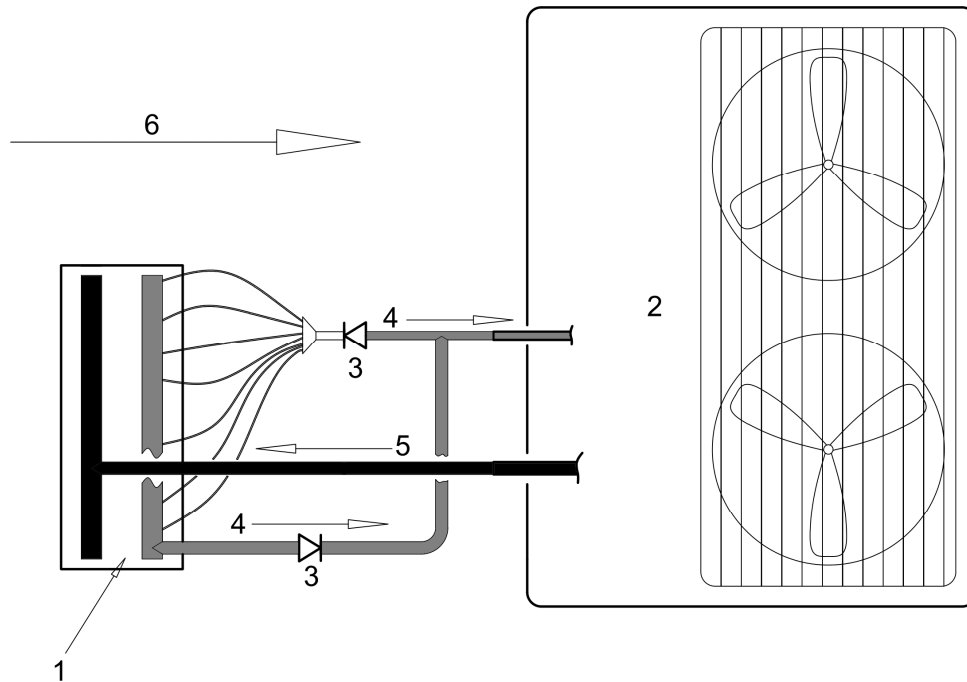

Figure 6.3.3.4 - Reversible refrigerant flow, three-pipe coil, heating mode.

1 – Condenser (heating mode), 2 – outside unit, 3 – check valve, 4 – refrigerant flow (out of the coil), 5 – refrigerant flow (into the coil), 6 – airflow direction

#### Dismantling:

1. Whenever a cooler is to be dismantled and removed from a system, it is important to stop refrigerant supply to cooler (close shut-off valves before cooler).
2. Release panel blocks 2.
3. Take off panels 3 together with sealing ring's covers 9 and sealing rings 4 itself.
4. Unscrew screws and disengage fastening elements 5 presented at the bottom and at the top.
5. Take out the cooler 6 and droplet eliminator 8.
6. DX cooler is mounted conversely to dismantlement sequence.
7. After mounting there should be ensure tightness between cooler casing and frame construction, tubes and protection cover.
8. Protect connection tubes and aluminium fins from deformation while mounting cooler into the air handling unit.
9. Make sure that airflow does not get into header of coil when coil is mounted.

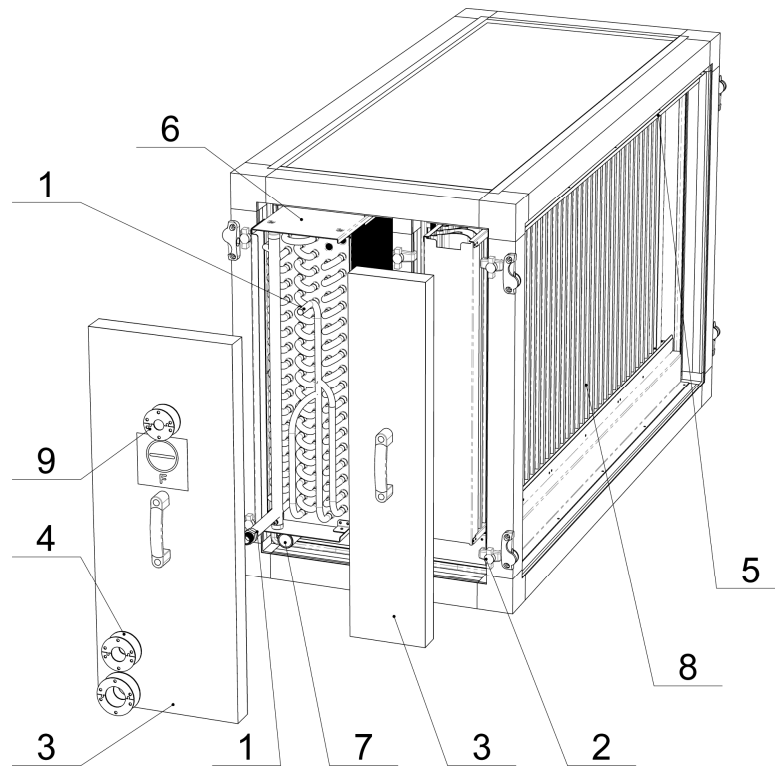

Figure 6.3.3.5 - DX cooler section.

1 – Refrigerant inlet/outlet, 2 – panel blocks, 3 – removable panel, 4 – sealing ring, 5 – fastening elements, 6 – DX cooler, 7 – condensate tray, 8 – droplet separator, 9 – sealing ring's cover.

### 6.3.4. Electrical heater

#### Description:

The electrical heaters designed for heating air by converting electrical energy to heat and mounted in the unit.

#### Technical data:

1. The casing is made of Aluzinc steel sheet.
2. Stainless steel heating elements.
3. Two-stage overhear protection. Overheat protection used to protect heater from overheating if airflow is too slow or system is breakdown. First stage (automatic) overheat protection activates at 50°C and reverses automatically when it cools down. Second stage (manual) overheat protection activates at 100°C, it should be resettled manually by pressing "RESET" switch (-s).

#### Connection to mains power:

1. Electrical connection may only be undertaken by technically trained personnel.
2. Electrical heaters should be connected to the standard mains power: three phase 230V / 50Hz or three phases 400V / 50 Hz. Wiring diagram is located on the inner side of the cover of electrical heater.
3. Heater should be connected to the mains supply with stationary cable that carried out thought rubber ledge.



4. Construction of power supply should be made so that voltage is supplied firstly to the fan and then to the electrical heater.
5. Construction of power disconnecting should be so that voltage is disabled firstly from the electrical heater and then from the fan.
6. Refer to separate “Electrical installation, operation and maintenance manual” document for more information.

Installation:

1. Distance from electrical heater and metallic or combustible materials should be not less than 100mm.
2. Distance from elbows, dampers must be not less than double diagonal of heater. Otherwise the airflow will not be even and the overheat protection may be activated.

Maintenance and cleaning:

1. If heater is contaminated, clean it with brush, vacuum cleaner or with direct air stream.

Dismantling:

1. Whenever a heater is to be dismantled and removed from a system, firstly disconnect it from main power supply.
2. Release panel blocks 1 and take off panel 2.
3. Unscrew and take off electrical heater cover 3.
4. Disconnect lead from electrical heater terminal box.
5. Take out the heater 5.
6. The electrical heater mounted conversely to dismantlement sequence.

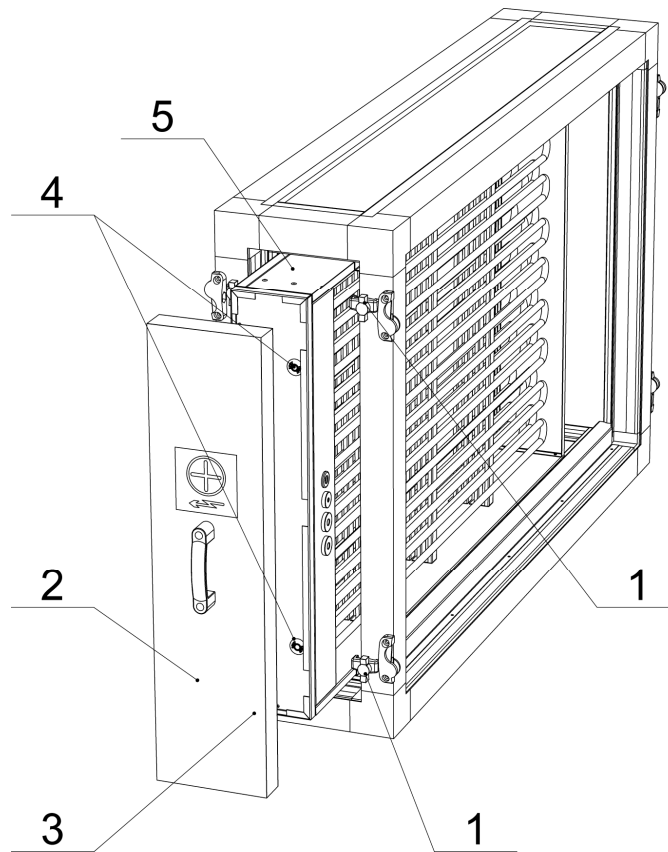

Figure 6.3.4.1 - Electric heater section.

1 – Panel blocks, 2 – removable panel, 3 – electrical heater cover, 4 – reset button (-s), 5 – electrical heater.

Overheat protection:

If overheat protection activates:

1. Disconnect heater from the mains supply.
2. Analyse and eliminate reasons of activation overheat protections thoroughly.
3. When failures are eliminated, restore manual overheat protection, i.e. push "RESET" switch (-s) 4. For this purpose release panel blocks 1 and take off panel 2.
4. Check if the heater works properly (no overheating).

Establishment of malfunctions:

Malfunction	Reason of malfunction	Eliminating malfunction
Full heating no regulation	Malfunction is in electrical circuit up to heater (controller, thermostat).	Check control devices and eliminate malfunction.
No heating	If there is no voltage on the contacts of heater then malfunction in electrical circuit up to heater (controller, fuses, thermostats, switches, etc.).	Check control devices and eliminate malfunction.
	If there is voltage on the contacts of heater then malfunction in overheat protections, heating elements.	Check contacts of overheat protections, measure voltage on heating elements and eliminate malfunction.

### 6.3.5. Steam heater

#### Description:

The steam heater designed to heat air with steam and mounted in the unit.

#### Technical data:

1. Normal air velocity 2-4m/s. Max permissible air velocity 5m/s.
2. Max permissible operating pressure: 1MPa at a max permissible operating temperature of 185°C.
3. The coil consist of copper tubes and aluminium fins. The casing is made of hot galvanized steel sheet or AluZn 185 steel sheet. Other materials on request.
4. All the connections are fitted with male pipe threads (SS-EN ISO 228-1).

#### Important:

1. The steam's pH-value should be between 8.8 and 9.2. The oxygen (O<sub>2</sub>) content must not exceed 0.01 mg/kg. Ammonia content (NH<sub>3</sub>) must not exceed 0.3 mg/kg.
2. Connect coil with steam to the upper pipe and the return to the lower pipe (Figure 6.3.5.1).

#### Maintenance and cleaning, dismantling:

Refer to section "6.3.1. Water heater".

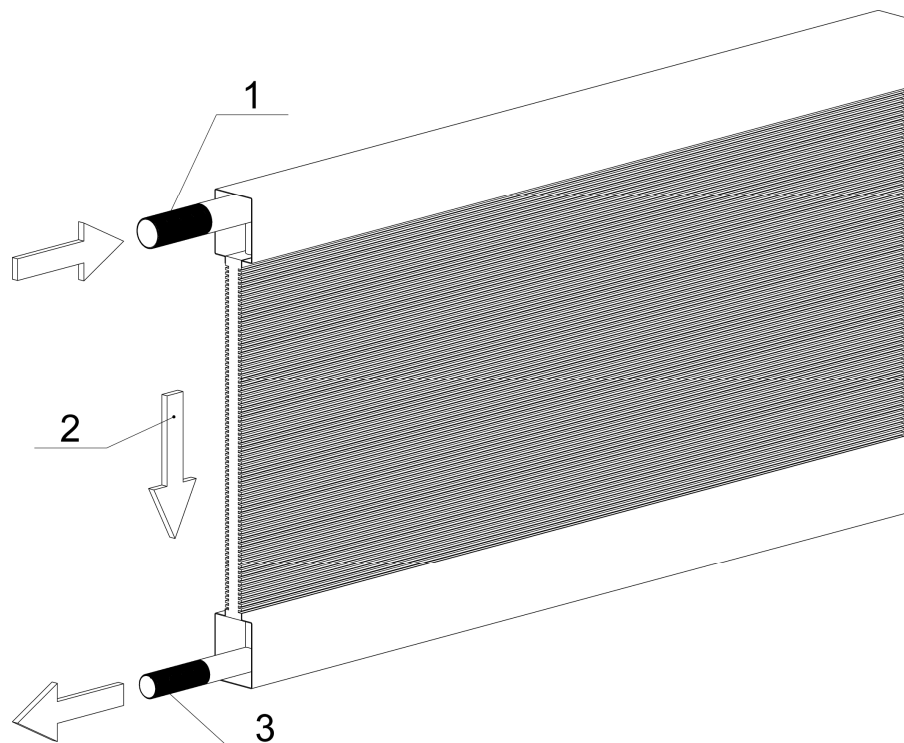

Figure 6.3.5.1 - Steam heater.

1 – Supply pipe, 2 – vertical steam transfer, 3 – return pipe.

### 6.3.6. Gas-fired heater

#### Description:

The gas-fired heater designed to heat air with natural or propane gas and mounted in the unit.

#### Technical data:

1. Nominal heating output from 11 to 200 kW for single units, up to 600 kW for multiple units.
2. Models available for indoor or outdoor applications.
3. Controls type: 10V modulating.
4. Tubes of the heat exchanger are made of stainless steel or aluminized steel.
5. Natural gas consumption from 2.1 to 28.7 m<sup>3</sup>/h, LPG consumption from 1,57 to 21,12 kg/h.
6. Airflow range from 1465 to 52500 m<sup>3</sup>/h.
7. Heating efficiency up to 91%.

#### Maintenance and cleaning:

1. If heater is contaminated, clean it with brush, vacuum cleaner or with direct air stream.
2. Observe the gas-fired heater manufacturer's operating instructions.

#### Dismantling:

1. Whenever a heater is to be dismantled and removed from a system, firstly disconnect it from power supply, gas supply 3, flue outlet 5 and combustion air inlet 4 (for indoor version).
2. Release panel blocks 1.
3. Take off panel (-s) 5 and aluminium profiles 7.
4. Release fastening elements 8.
5. Take out the heater 2.
6. The gas-fired heater mounted conversely to dismantlement sequence.

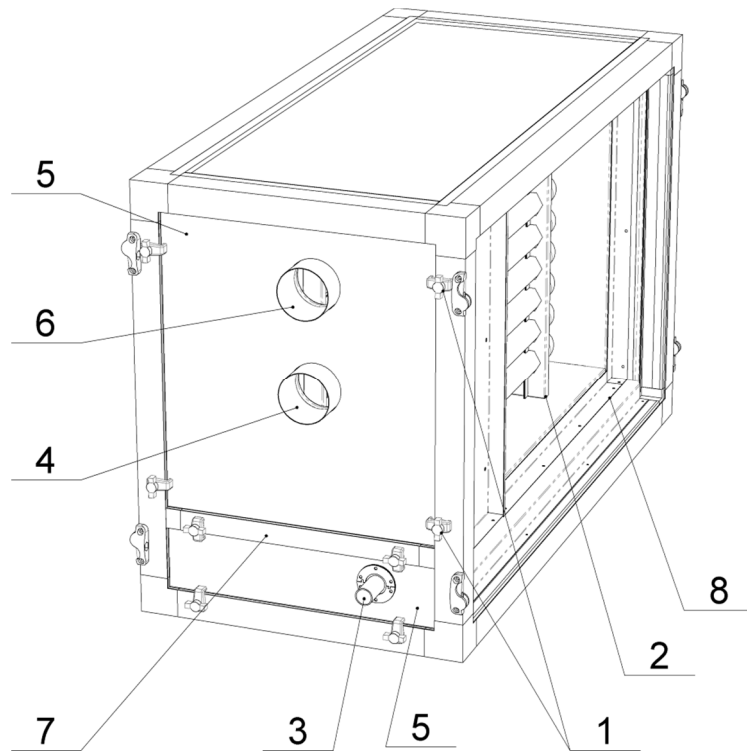

Figure 6.3.6.1 - Gas-fired heater section, indoor version.

1 – Panel blocks, 2 – gas-fired heater, 3 – gas inlet, 4 – combustion air inlet, 5 – removable panels, 6 – flue outlet, 7 – aluminium profiles, 8 – fastening elements.

Note: Gas inlet pipe 3, combustion air inlet pipe 4 and flue outlet pipe 6 are not provided for indoor version.

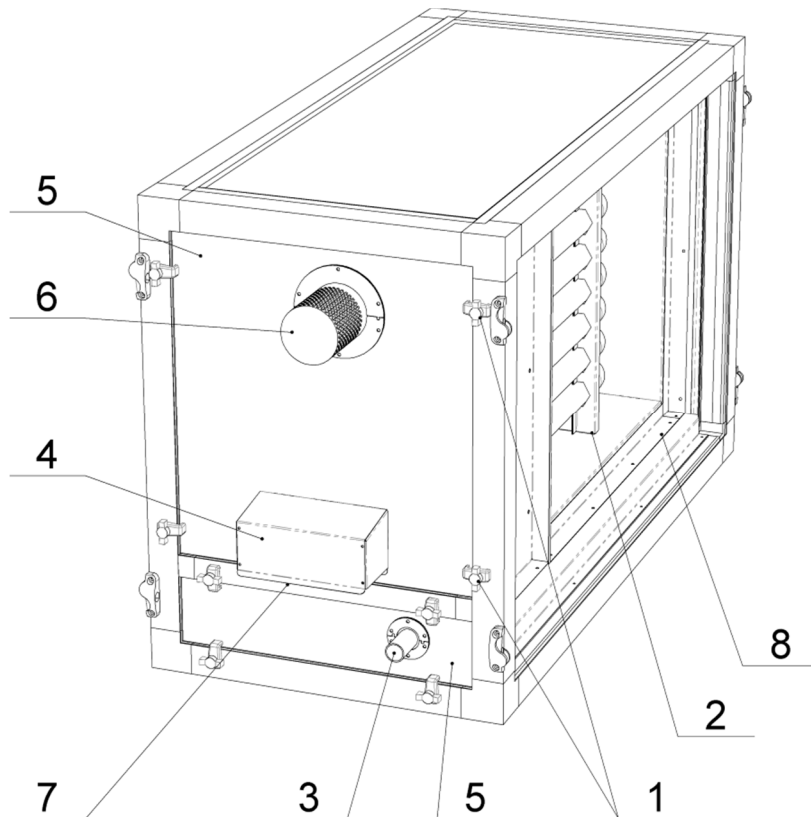

Figure 6.3.6.2 - Gas-fired heater section, outdoor version.

1 – Panel blocks, 2 – gas-fired heater, 3 – gas inlet, 4 – combustion air inlet, 5 – removable panels, 6 – flue outlet, 7 – aluminium profiles, 8 – fastening elements.

Note: Gas inlet pipe 3 is not provided for outdoor version.

## 6.4. Air filters

### Description:

1. The air filters in a ventilation system prevent dust and other impurities reaching the premises. They also protect sensitive components in the air handling unit, such as air heaters, coolers and heat exchangers from contamination.
2. The air filters usually shipped loose, packed in foil or in boxes, inside the air handling unit. It is essential to install air filters before putting the unit into operation, thus making sure sensitive components and ductwork are protected and kept clean.
3. Changing of filter should be primarily based on clogging, indicated by final pressure drop. However, for hygienic reasons, filters in the first filter section should not be in use for more than one year. Filters used in a second or third section, should not be in use for more than two years. When dry conditions in all filter sections are guaranteed at all times, longer period of use are possible if the pressure drop remains below the defined maximum. Both visual inspection and monitoring of pressure drop is recommended (refer to section 8.10. Filter contamination control accessories).
4. A maximum of 90% RH is allowed before each filter section for hygienic units.

### 6.4.1. Panel filter

#### Description:

1. Panel filter with galvanized steel sheet or AluZn 185, AISI 304 or AISI 316 steel sheet frame and G4 filtration class synthetic media. Pre filter for comfort air conditioning applications.
2. Slide type filter rack made of galvanized steel sheet, AluZn 185 steel sheet, AISI 304 steel sheet or AISI 316 steel sheet.
3. Temperature resistant up to 110°C.

#### Maintenance:

1. Panel filter designed for one-time use. Replace clogged filter with the new one of the same quality and dimensions as the original.
2. Replace filter when the pressure loss reaches the specified final pressure loss. Timely filter replacement ensures energy efficiency of the unit.
3. Maintenance interval in accordance with the degree of contamination of the filters (at least 3 months).
4. Keep at least one set of replacement filters in stock. Store in a dry and dust free area. Avoid contamination and damage.

#### Replacement:

1. Stop the AHU before filter replacement. This will prevent the penetration of any dust into the ventilation system falling from filter during replacement.
2. Use particulate respirator during replacement.
3. Release panel blocks 3.
4. Take off panel 1.
5. Take out filter 2.
6. Vacuum clean the inner surfaces of the filter section and/or wipe it clean with a damp cloth.
7. Insert new filters, set back panel 1 and fix it.

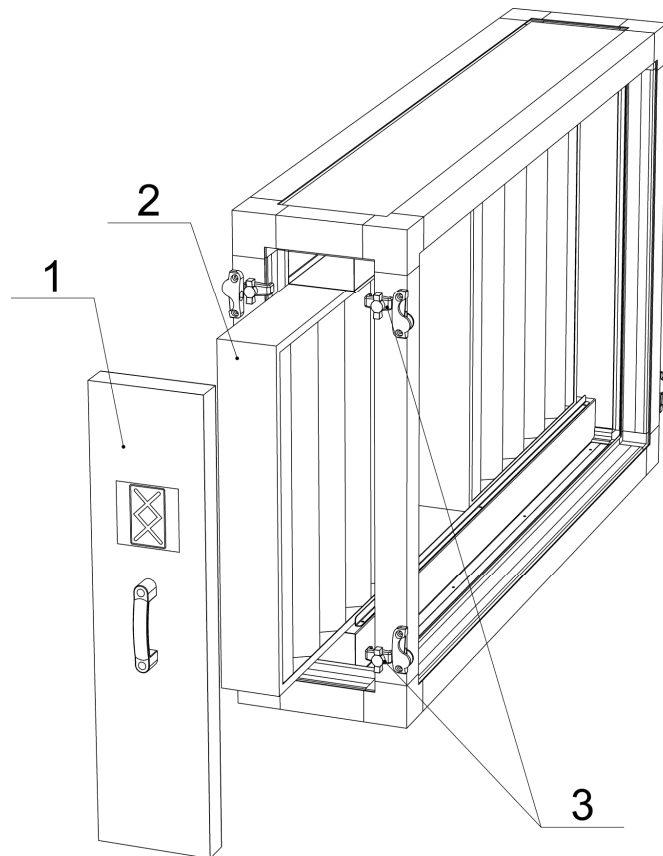

Figure 6.4.1.1 - Panel filter section.  
1 – Removable panel, 2 – panel filter, 3 - panel blocks.

## 6.4.2. Pocket filter

### Description:

1. Pocket filter with AluZn 185 steel sheet or plastic frame and M5, F7 or F9 filtration class synthetic media. Main filter for comfort air conditioning applications.
2. Slide type filter rack made of galvanized steel sheet, AluZn 185 steel sheet, AISI 304 steel sheet or AISI 316 steel sheet.
3. Temperature resistant M5 up to 110°C, F7 and F9 up to 80°C.
4. Drip tray available as option.

### Maintenance:

1. Pocket filter designed for one-time use. Replace clogged filter with the new one of the same quality and dimensions as the original.
2. Replace filter when the pressure loss reaches the specified final pressure loss. Timely filter replacement ensures energy efficiency of the unit.
3. Maintenance interval in accordance with the degree of contamination of the filters (at least 3 months).
4. Keep at least one set of replacement filters in stock. Store in a dry and dust free area. Avoid contamination and damage.

Replacement:

1. Stop the AHU before filter replacement. This will prevent the penetration of any dust into the ventilation system falling from filter during replacement.
2. Use particulate respirator during replacement.
3. Open service door 1 or remove maintenance panel.
4. Open quick-release filter mechanism 2.
5. Take out filters 3.
6. Vacuum clean the inner surfaces of the filter section and/or wipe it clean with a damp cloth.
7. Check filter gasket for possible damage and change it with new one if necessary.
8. Insert new filters.
9. Close quick-release filter mechanism 2.
10. Close service door or put on maintenance panel.

Important:

Pocket filters shall always be installed with the pockets in a vertical position (Figure 6.4.2.1).

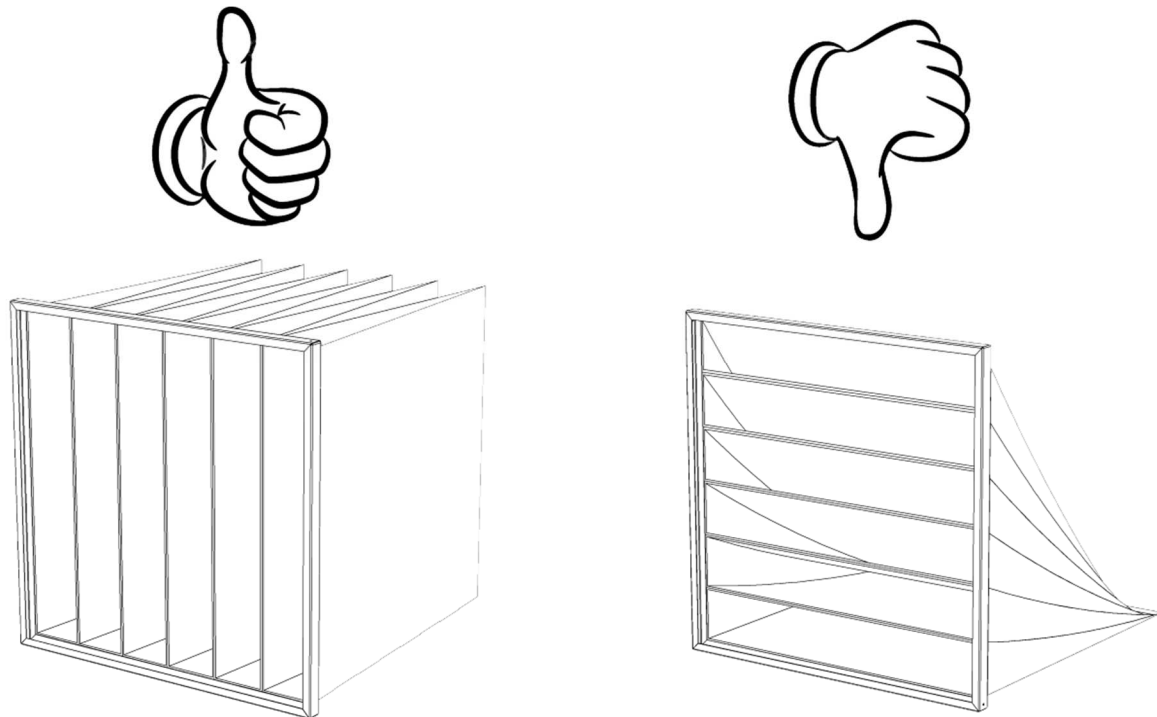

Figure 6.4.2.1 - Pocket filter in a vertical position.



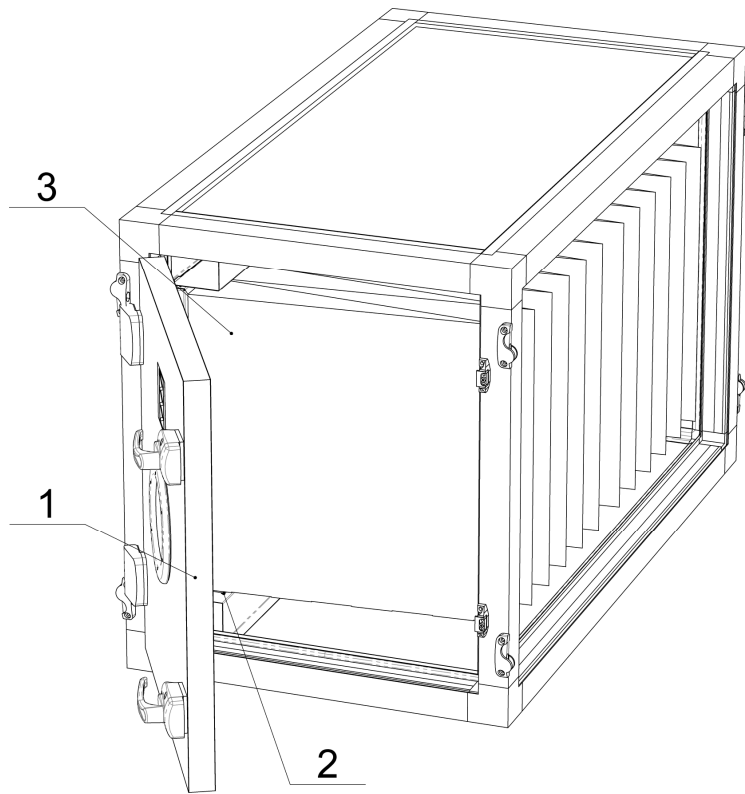

Figure 6.4.2.2 - Pocket filter section.  
 1 – Service door, 2 – pocket filter.

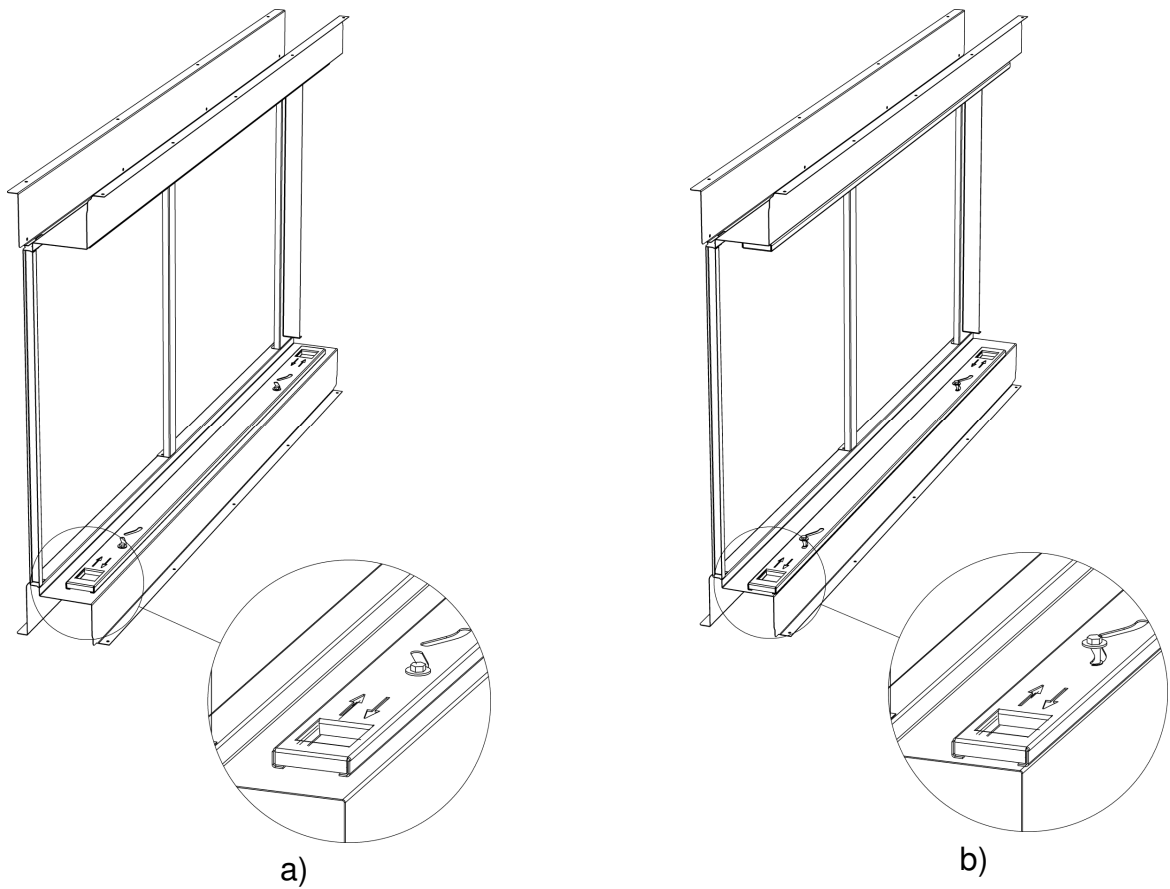

Figure 6.4.2.3 - Pocket filter rack.  
 a – quick-release mechanism closed, b – quick-release mechanism open.

### 6.4.3.EPA / HEPA filter

#### Description:

1. Efficiency particulate arrestance (EPA) air filter class E10 or E11.
2. High efficiency particulate arrestance (HEPA) air filter class H13 or H14.
3. Very high efficiency final filtration in air conditioning systems.
4. Special coated galvanized steel holding frame.
5. Galvanized steel or stainless steel AISI 304 filter frame with hotmelt spacers and high efficiency micro glass fibre filter media.
6. EPA/HEPA filter rack made of galvanized steel sheet, AluZn 185 steel sheet, AISI 304 steel sheet or AISI 316 steel sheet.
7. Maximum temperature: 70°C.
8. Maximum relative humidity: 90%.
9. Gasket on clean air side.

#### Maintenance:

1. EPA / HEPA filter designed for one-time use. Replace clogged filter with the new one of the same quality and dimensions as the original.
2. Replace filter when the pressure loss reaches the specified final pressure loss. Timely filter replacement ensures energy efficiency of the unit.
3. Maintenance interval in accordance with the degree of contamination of the filters (at least 3 months).
4. Keep at least one set of replacement filters in stock. Store in a dry and dust free area. Avoid contamination and damage.

#### Replacement:

1. Stop the AHU before filter replacement. This will prevent the penetration of any dust into the ventilation system falling from filter during replacement.
2. Use particulate respirator during replacement.
3. Open service door 1.
4. Release fixing bolts 4 on filter frame 2.
5. Take out filters 3.
6. Vacuum clean the inner surfaces of the filter section and/or wipe it clean with a damp cloth.
7. Insert new filters, tighten fixing screws, close service door. Use filters with gasket on clean air side only.

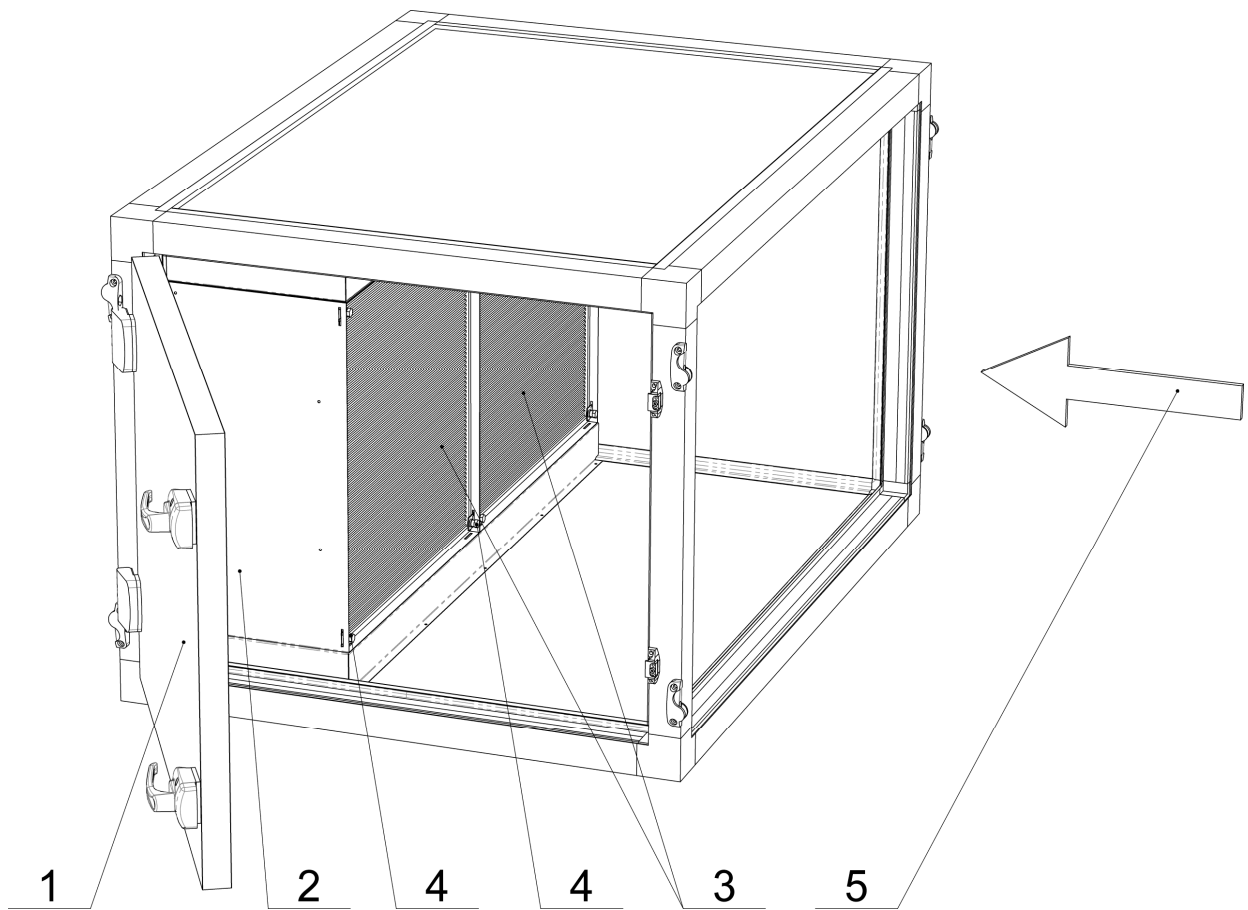

Figure 6.4.3.1 - EPA / HEPA filter section.

1 – Service door, 2 – filter frame, 3 – HEPA/EPA filter, 4 – fixing bolts, 5 – airflow.

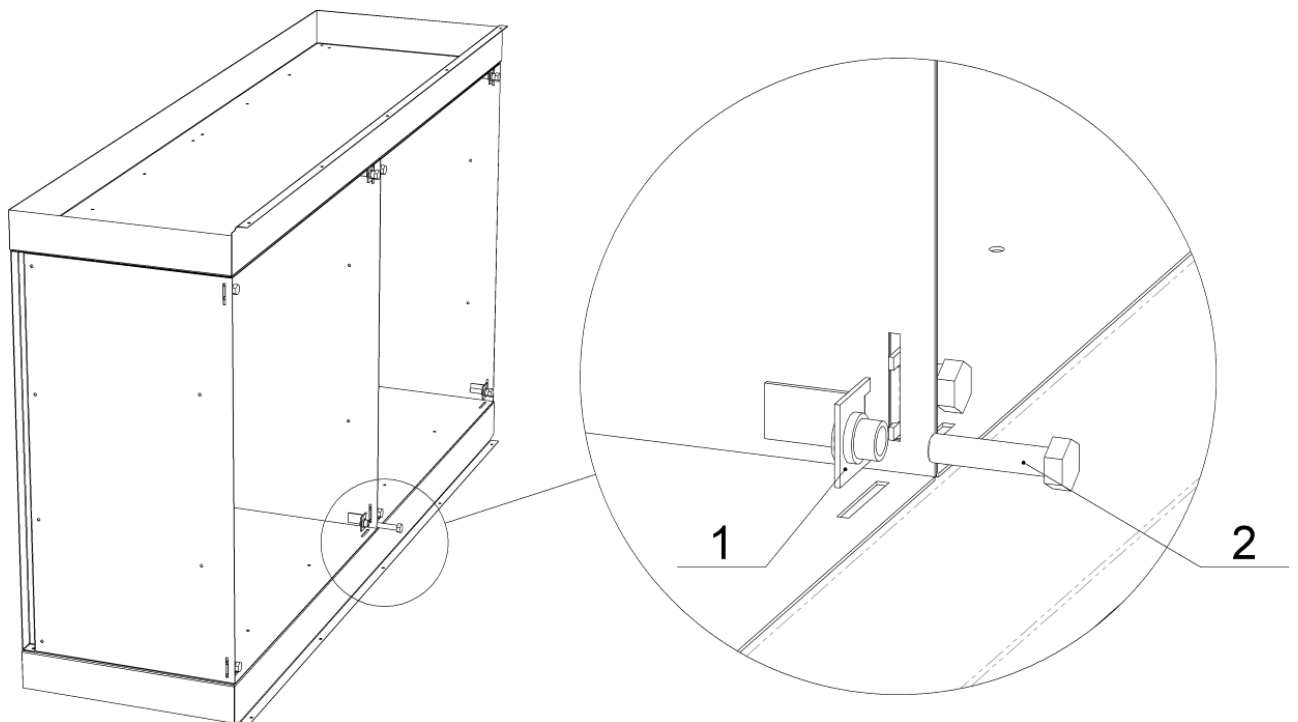

Figure 6.4.3.2 - EPA / HEPA filter rack.

1 – Fixing block, 2 – fixing bolt.

#### 6.4.4. Activated carbon cartridges filter

##### Description:

1. For purification of supply air-, exhaust air- and circulating air streams from harmful gases, steams and bad smells in canteen kitchens, museums, hospitals, laboratories, computer areas, chemical industry, paint shops, airports, petrol stations, parking garages.
2. Galvanized steel or stainless steel AISI 304 cartridges filled with untreated carbon.
3. Holding frame made of galvanized steel sheet, AluZn 185 steel sheet, AISI 304 steel sheet or AISI 316 steel sheet.
4. Temperature resistant up to 70°C.
5. Minimum contact period depending on application 0.05s to 1.0s.
6. Pre-filtration is necessary, required filter class F7.

##### Maintenance:

1. Replace the filter if activated carbon is saturated. For monitoring the filter's saturation level check the filter's odour or, if you have the necessary equipment, make measurements in the air to determine when change need to be done. Weighting of cartridges don't give good results because most of the additional weight is caused by the air humidity.
2. To prevent the reduction of expensive activated carbon filter's service life ensure that the pre filtering and fine filtering stages are in proper condition.

##### Replacement:

1. Stop the AHU before filter replacement.
2. Open service door 1.
3. Cartridges 2 secured with bayonet closure 4. Turn the filter cartridges with cartridge key 3 as indicated by the rotation arrow and remove from the frame. Cartridge key supplied with air handling unit.
4. Replenish or replace the activated carbon filter together with pre filter.
5. Dispose filters in accordance with the applicable regional regulations.

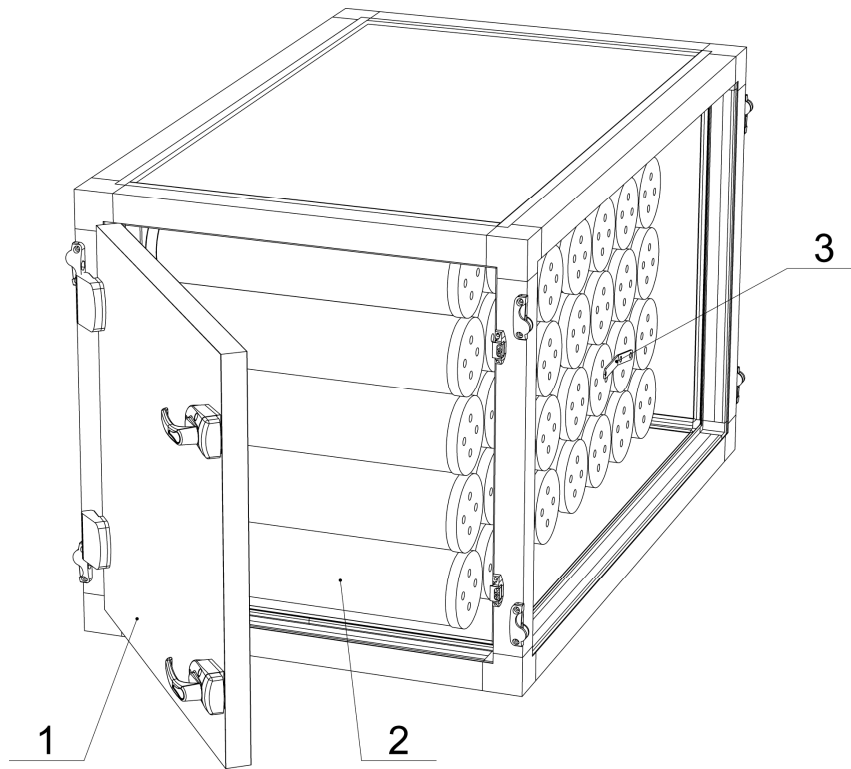

Figure 6.4.4.1 - Activated carbon filter section.  
 1 – Service door, 2 – Activated carbon cartridge, 3 – cartridge key.

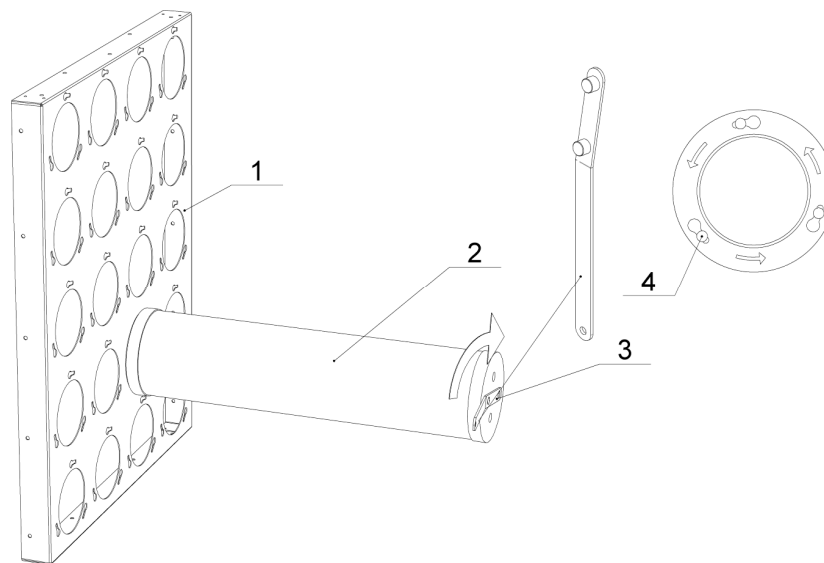

Figure 6.4.4.2 - Installation of activated carbon cartridge by “push and turn”.  
 Arrow indicates fixing direction. 1 – Holding frame, 2 – activated carbon cartridge, 3 – cartridge key, 4 – bayonet closure.

### 6.4.5. Grease filter

Description:

1. Filter for grease elimination or coarse dust removal. Used in kitchen extract systems or pre filtration within air conditioning systems.

2. Panel filter cells in aluminium wire mesh.
3. Slide type filter rack made of galvanized steel sheet, AluZn 185 steel sheet, AISI 304 steel sheet or AISI 316 steel sheet.
4. Filter section with grease-collecting tray.
5. Temperature resistant up to 200°C.

Maintenance:

1. Maintenance interval in accordance with the degree of contamination of the filters (at least every month). In case of extraction of highly greased air (for example in kitchens) it is recommended to wash grease filters every day. Clean grime using warm water and alkaline mixture, which does not generate corrosion to aluminium. Alternatively clean filters using a high-pressure jet.
2. Clean grease-collecting tray.

Replacement:

1. Stop the AHU before filter replacement.
2. Release panel blocks 1
3. Remove maintenance panel.
4. Pull out the grease filter 3.
5. Insert new or washed filter, set back maintenance panel.

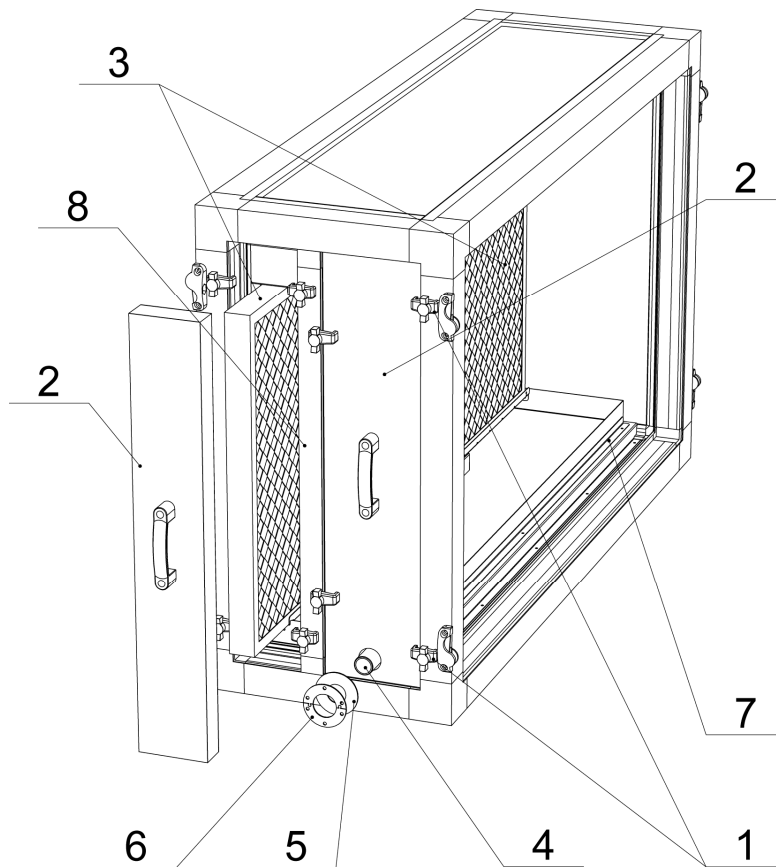

Figure 6.4.5.1 - Grease filter section.

1 – Panel blocks, 2 – removable panels, 3 – grease filters, 4 – drip tray, 5 – sealing ring, 6 – sealing ring’s cover, 7 – fastening elements, 8 – aluminium profile.

## 6.5. Humidifiers

### 6.5.1. Steam humidifier

#### Description:

Immersed electrode humidifier for comfort air conditioning applications. Humidifier consist of humidifier cabinet placed near air handling unit and steam distributors installed inside air handling unit section with stainless steel drip tray or inside air ductwork. Two humidifier types available: X-plus and Basic.

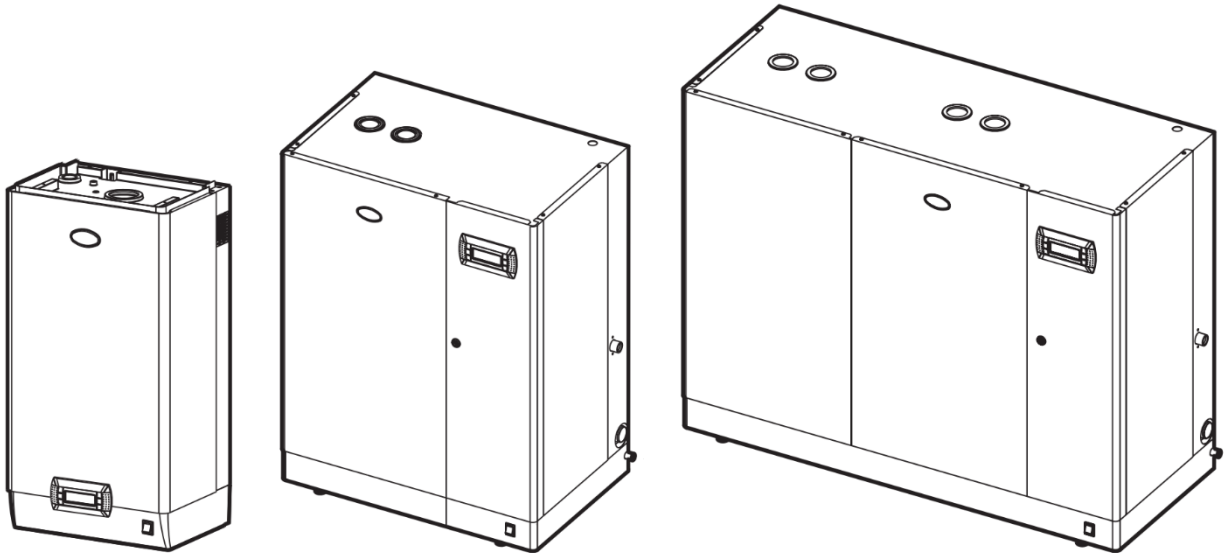

Figure 6.5.1.1 - Different size humidifier cabinets.

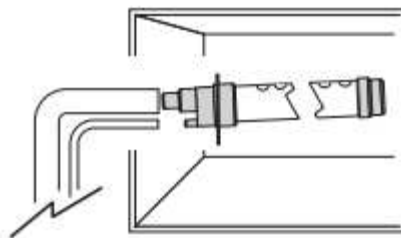

Figure 6.5.1.2 - Linear steam distributor in ductwork.

#### X-plus type:

1. Humidification range from 1 to 130 kg/h.
2. Built-in controller with graphic display and keypad for programming and controlling operation. The following modes can be selected:
  - ON/OFF by external humidistat;
  - Proportional based on an external voltage or current signal;
  - Proportional based on an external signal plus a safety limit probe in the duct;
  - Modulating based on the set point and a humidity probe reading;
  - Modulating based on the set point, a humidity probe reading and a limit probe in the duct;

- Modulating based on the set point and the reading of an external temperature probe (e.g. steam baths);
  - Controlled by BMS.
3. The steam flowrate modulated continuously from 20 to 100% of maximum capacity (10 - 100% in the 90 & 130 kg/h models). This type humidifier can accept the following signals, selected on the keypad: voltage-free contact from a humidistat, 0 - 1 V, 0 - 10 V, 2 - 10 V, 0 - 20 mA, 4 - 20 mA, 0 - 135 Ohm external load.
  4. Simplicity, with the graphic display and messages in different languages.
  5. Operation with daily and weekly time bands & variable set points.
  6. BMS connectivity via various types of LAN (e.g.: Modbus®, BACnet™, LON®). Complete diagnostics with text messages, alarm log with time stamping.
  7. Complete diagnostics with text messages, alarm log with time stamping.
  8. Automatic draining in standby.

#### Basic type:

1. Humidification range from 1 to 65 kg/h.
2. ON/OFF or proportional control (voltage or current signal).
3. Flowrate modulation: 20% - 100%.
4. Adjustable maximum capacity.
5. Cylinder life counter.
6. Automatic draining in standby.
7. Complete diagnostics with memory.
8. Large LCD display with numbers and graphic icons for easy and intuitive operation.

#### Steam and electrical connection:

Refer to manufacturer's operating instructions.

#### Maintenance and cleaning:

Clean humidifier section inside surfaces, spray nozzles and drip tray at regular interval (at least 1 month).

### 6.5.2. Evaporative humidifier

#### Description:

Evaporative humidifier employ water evaporation produced by air currents. Used for air humidification or for indirect adiabatic cooling. Air passes through a sheet of water and partially evaporates it. The water vapour added to the air's mix, which is at the same time cooled.

#### Technical data:

1. Units with recirculation in order to save water or direct water units to reduce maintenance work.
2. Stainless steel drip tray.
3. Droplet eliminator always included if air speed through humidifier from 3,5m/s. Optional for lower speeds.
4. Optional UV lamp water treatment system.



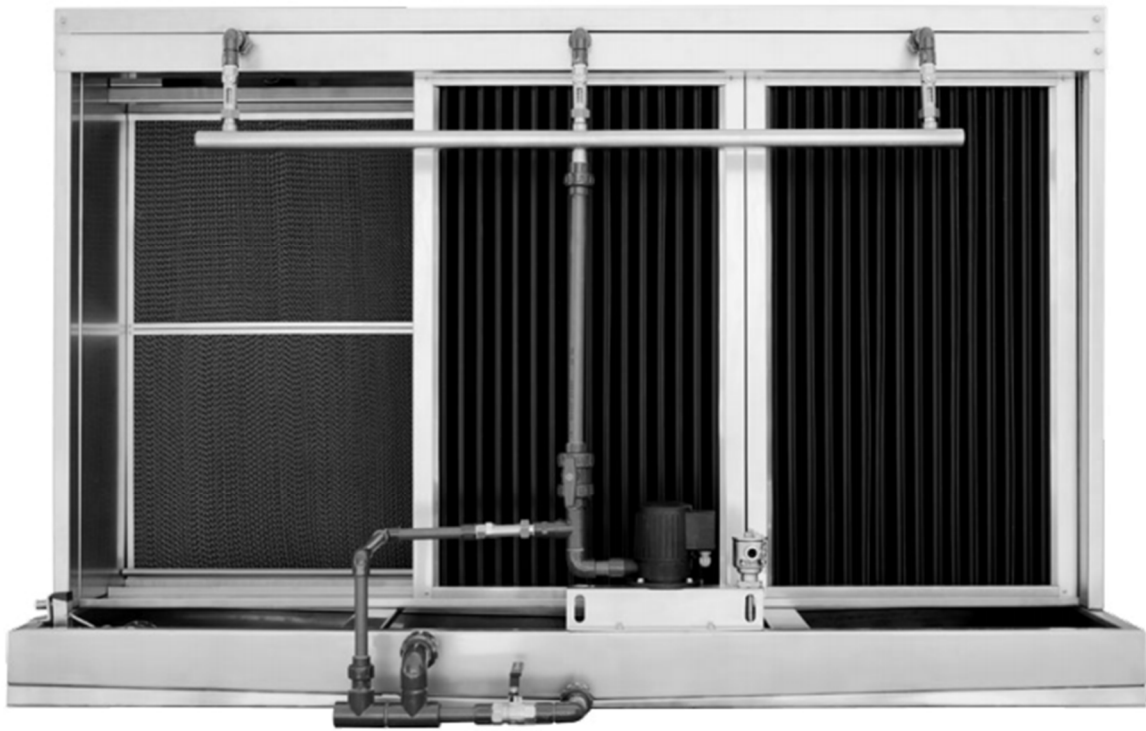

Figure 6.5.2.1 - Evaporative humidifier.

Water and electrical connection:

Refer to manufacturer's operating instructions.

Maintenance and cleaning:

Clean humidifier section inside surfaces, panels, piping and drip tray at regular interval (at least 1 month during humidification period). For more information refer to manufacturer's operating instructions.

Important:

In the units with direct water evaporative humidifiers (HEF2E-DW), to prevent possible condensations, it's a must to isolate the stainless steel manifold and pipes when the temperature of the feed water is below the dew point of the downstream air flow after the wetting panel.

## 6.6. Damper section

Description:

The function of dampers is to control air supply to ducts, to close unit when the system is off, to prevent cold air to get in to the premises. There could be negative consequences if dampers function not properly. For example water heater can freeze if there is no hot water in it. If dampers are not fully open the AHU would not work in total capacity.

Technical data:

1. Damper section (damper inside casing). Class 2 or class 4 tightness according to EN 1751:2014.

2. Standalone damper with PG type connection. Class 2 or class 4 tightness according to EN 1751:2014.
3. Dampers frame and blades made from aluminium.
4. Damper actuator or manual control available on request.

Maintenance and cleaning:

1. Check effectiveness of a damper. Check if it is opening and closing normally (so that the “full open” and “full close” conditions are satisfied).
1. Check is there no deformation (blades 1, frame 2).
2. Check is damper mounted tightly (there should be sealing strip or sealant between casing of section and frame of damper).
3. If actuator is mounted when check if it works properly. Check if it properly connected with driving axis of damper 3.
4. Clean blades and joints of dampers with liquid which does not generate the corrosion of aluminium.

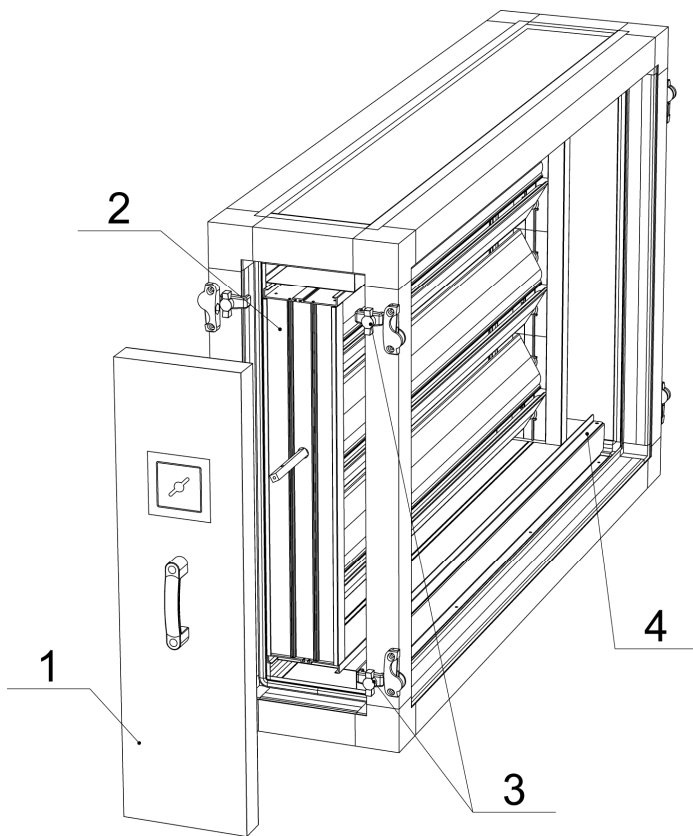

Figure 6.6.1 - Damper section.

1 – Removable panel, 2 – damper, 3 – panel block, 4 – fastening element.

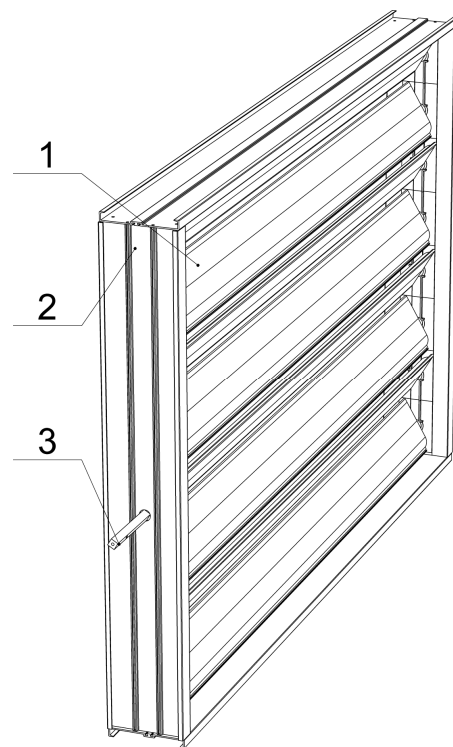

Figure 6.6.2 – Damper.

1 – Damper blades, 2 – damper frame, 3 – axis of damper.

## 6.7. Mixing section

Description:

Special section for outdoor air mixing with extract air. Optional stainless steel drip tray.

Types:

1. One stage mixing section with two dampers outside (Figure 6.7.1).
2. One stage mixing section with two dampers inside (Figure 6.7.2).
3. Two stage mixing section with three dampers inside (double deck (Figure 6.7.3) or side by side).
4. Two stage mixing section with only one middle damper inside (double deck (Figure 6.7.4) or side by side).

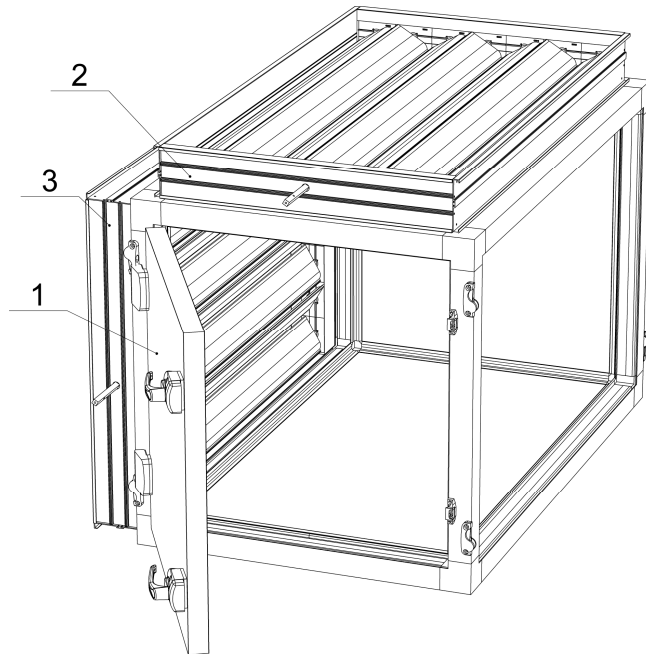

Figure 6.7.1 - One stage mixing section with two dampers outside.  
 1 – Service door, 2 – horizontal damper, 3 – vertical damper.

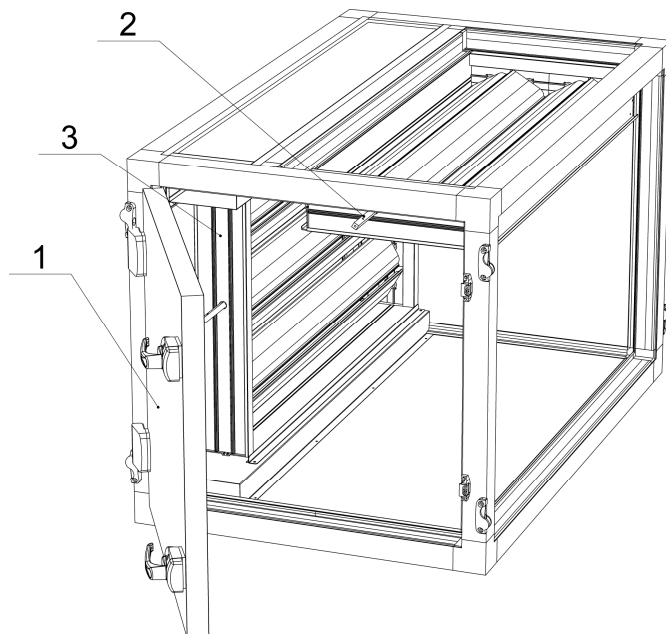

Figure 6.7.2 - One stage mixing section with two dampers inside.  
 1 – Service door, 2 – horizontal damper, 3 – vertical damper.

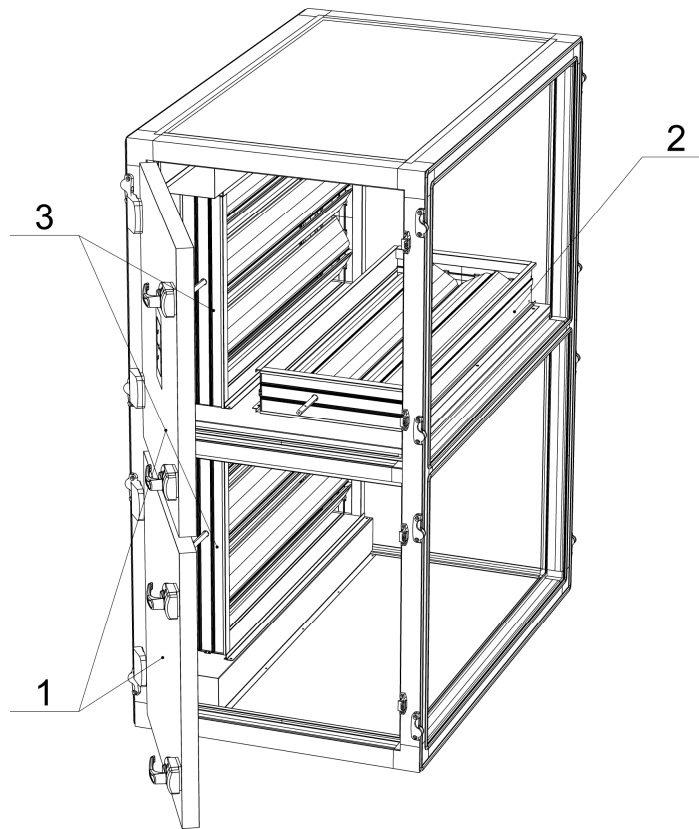

Figure 6.7.3 - Two stage mixing section with three dampers inside.  
 1 – Service door, 2 – horizontal damper, 3 – vertical damper.

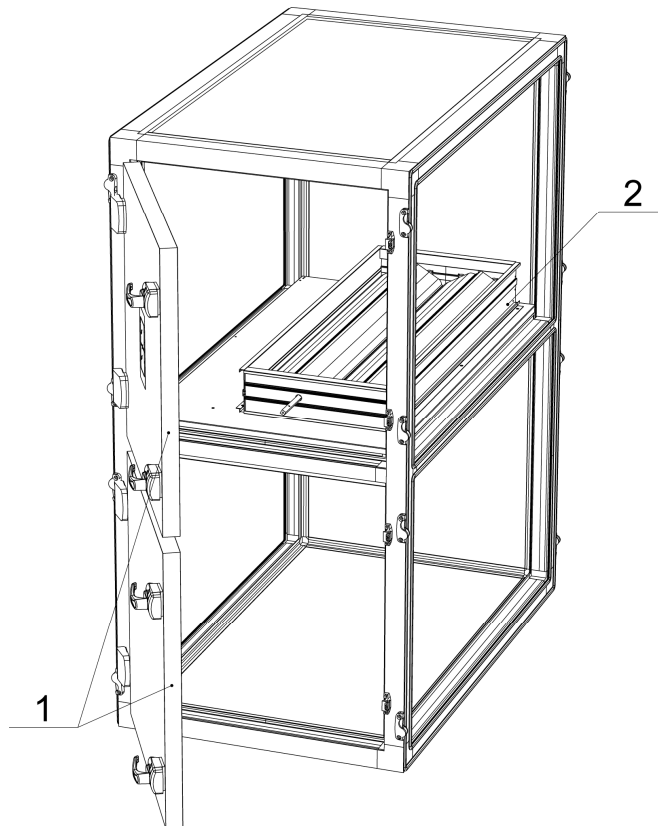

Figure 6.7.4 - Two stage mixing section with one damper inside.  
 1 – Service door, 2 – horizontal damper, 3 – vertical damper.

Maintenance and cleaning:

1. Refer to section “6.6. Damper section”.

**6.8. Service section**

Description:

1. Service air handling unit section for ease access to nearby components. Available with different access door or maintenance panel types:
  - Type A: access door with hinges and handles.
  - Type B: access door with hinges and handles, lockable.
  - Type C: maintenance panel with panel blocks and handle.
  - Type D: maintenance panel with panel blocks without handle.
2. Drip tray available as option.

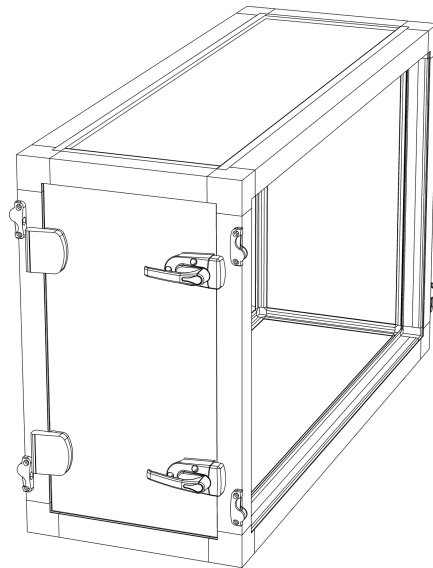

Figure 6.8.1 - Service section type A and B.

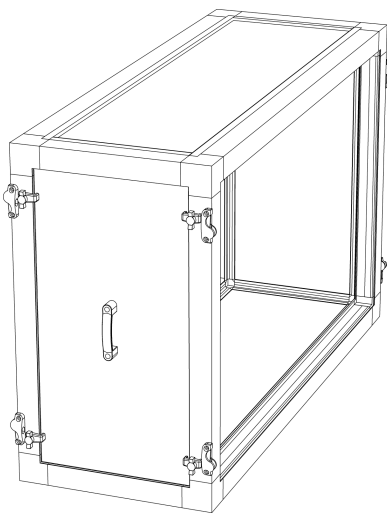

Figure 6.8.2 - Service section type C.

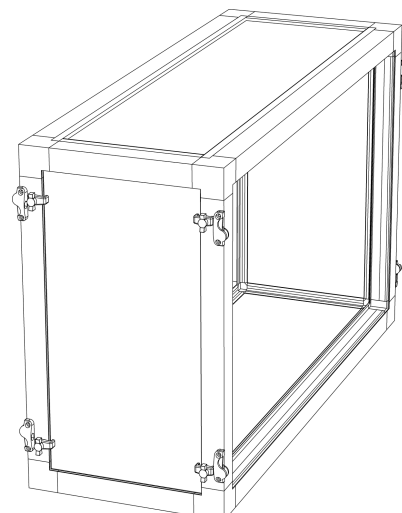

Figure 6.8.3 - Service section type D.

## 6.9. Droplet eliminator section

### Description:

Droplet eliminator section is used to prevent water drops to get downstream of it, in the duct or inside the air handling unit. It ensures higher air quality by removing possible causes of corrosion or the growth of bacteria and mildew.

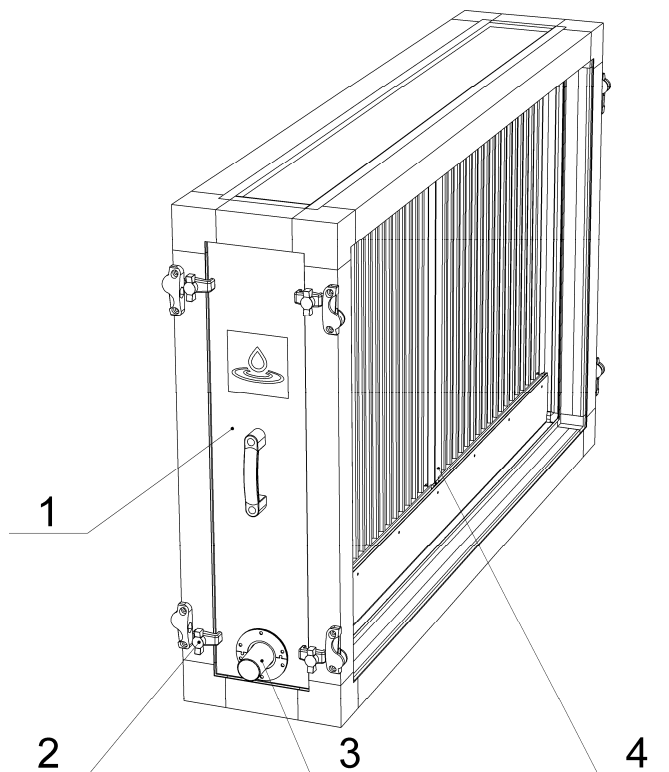

Figure 6.9.1 - Droplet eliminator section.

1 – Removable panel, 2 – panel blocks, 3 – drainage pipe, 4 – droplet separator.

## 7. Control system

### Description:

Control equipment customized according to every special customer need. All AmberAir units ordered with control system are factory configured and tested together with all the necessary field components. The control system conforms to EU directives (MD, EMC and LVD) and is CE marked. Units is self-contained and requires no major onsite electrical installation. The control equipment is ready to go as soon as the unit installed.

Control system sample shown in Figure 7.1. Specification of your control system provided in a separate document.

### Control system types:

1. Built in control system. All components are in control section.
2. Built in outside control system. Control cabinet mounted on the unit's doors or mounted on particular distance from the unit.
3. Not built in control system.

### Available controllers:

1. MCB (S-Touch; SA-Control).
2. Siemens (with POL871; POL822; POL 895 remote controller).
3. Regin (ED9100; E3-DSP).

### AmberAir controls features:

1. Indoor/outdoor operation possible (up to IP65).
2. PC control via Modbus (RS485), TCP/IP, LON, BACNet MSTP, Mbus, BACNet IP or Web.
3. Air quality control: CO<sub>2</sub>, humidity, constant pressure.
4. One or two remote controllers supported.
5. Plug and play – all components connected and tested.
6. Water heater/cooler actuator.
7. Filter contamination control (PS 600B).
8. Air supply, exhaust and mixing motorized dampers.
9. Sensors of different parameters.
10. Fire thermostats.
11. External switches.
12. Duct / room sensors for night cooling.
13. Frost protector for heating coil.
14. Smoke detector and fire damper with accompanying control unit.

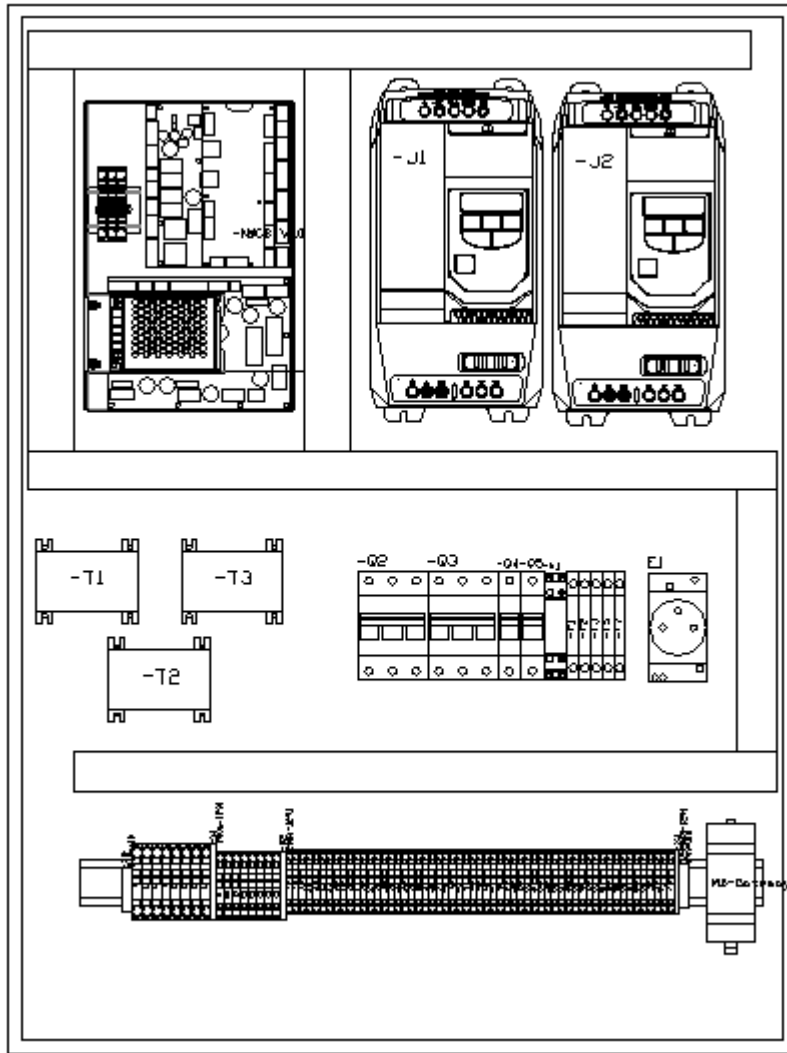

Figure 7.1 - AmberAir control system cabinet sample.



## 8. Accessories

### 8.1. Base frames

#### 8.1.1. Base frame type 1

Description:

Base frame type 1 (Figure 8.1.1.1) used to set air handling unit in parallel with foundation (it is very important to proper work of drainage system). Base frame type 1 can be adjustable or not adjustable. Adjustable base frame has two type of supporting foots: Type 1 – vibration-proof foot and Type 2 – adjustable angle foot. Type 2 foot allows to mount air handling unit on sloped surface.

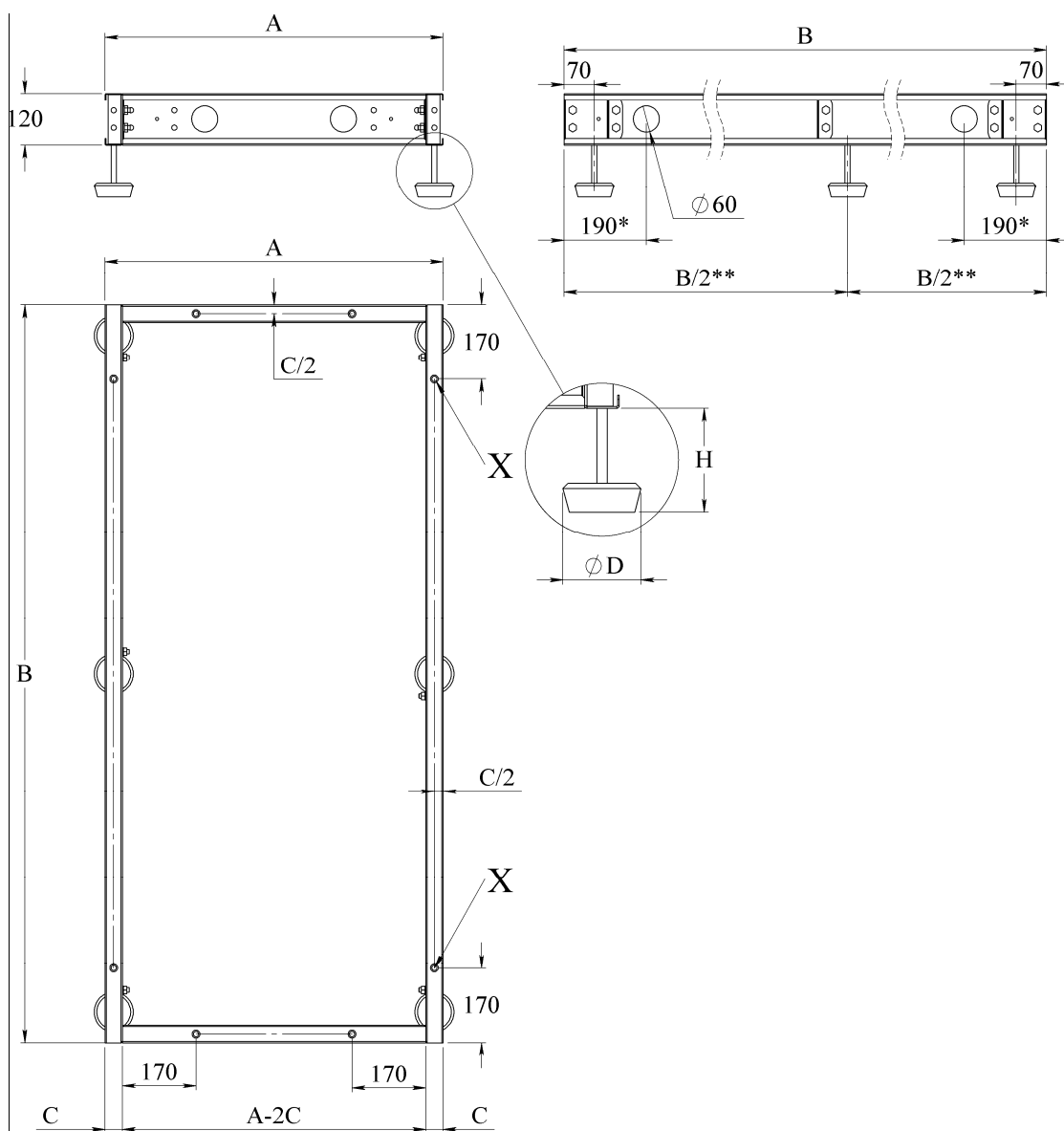

Figure 8.1.1.1 - AHU section base frame type 1.

A – AHU width, mm, B – AHU section length, mm, \* - opening for unloading section by crane if  $B \geq 610\text{mm}$ , \*\* - opening for additional vibration-proof foot if  $B \geq 1700\text{mm}$ , X – opening intended to connect base frame to AHU.

Available base frame heights E are 120 and 240mm. Other heights on request.

Base frame can be either fixed to AHU or delivered separately.

Vibration-proof foots type and measures  $\varnothing D$ , H, C and X depends on the unit size and the unit weight and given in Table 8.1.1.1.

Table 8.1.1.1 Base frame measures (foot type 1)

Unit size	Foot type	$\varnothing D$ , mm	H, mm	C, mm	X, mm
1-3KR	S000	40	55	40	13
4-6KR	S00	60	90	40	13
7-9KR	S0	70	105	40	13
10-16KR	S1	85	105	50	18
	S3	120	140	50	18

Adjustable angle foot types and measures  $\varnothing D$ , H, C and X depends on the unit size and the unit weight and given in the table 8.1.1.2.

Table 8.1.1.2 Base frame measures (foot type 2)

Unit size	Foot type	$\varnothing D$ , mm	H, mm	C, mm	X, mm
1-9KR	NF65-100X10	65	100	40	13
10-16KR	AMC159524	50	100	50	18

### 8.1.2. Base frame type 2

Base frame type 2 (Figure 8.1.2.1) used to set air handling unit in parallel with foundation (it is very important to proper work of drainage system). Base frame type 2 provides more space under the air handling unit for easier cleaning. It can be selected for AHU sizes 1-7KR.

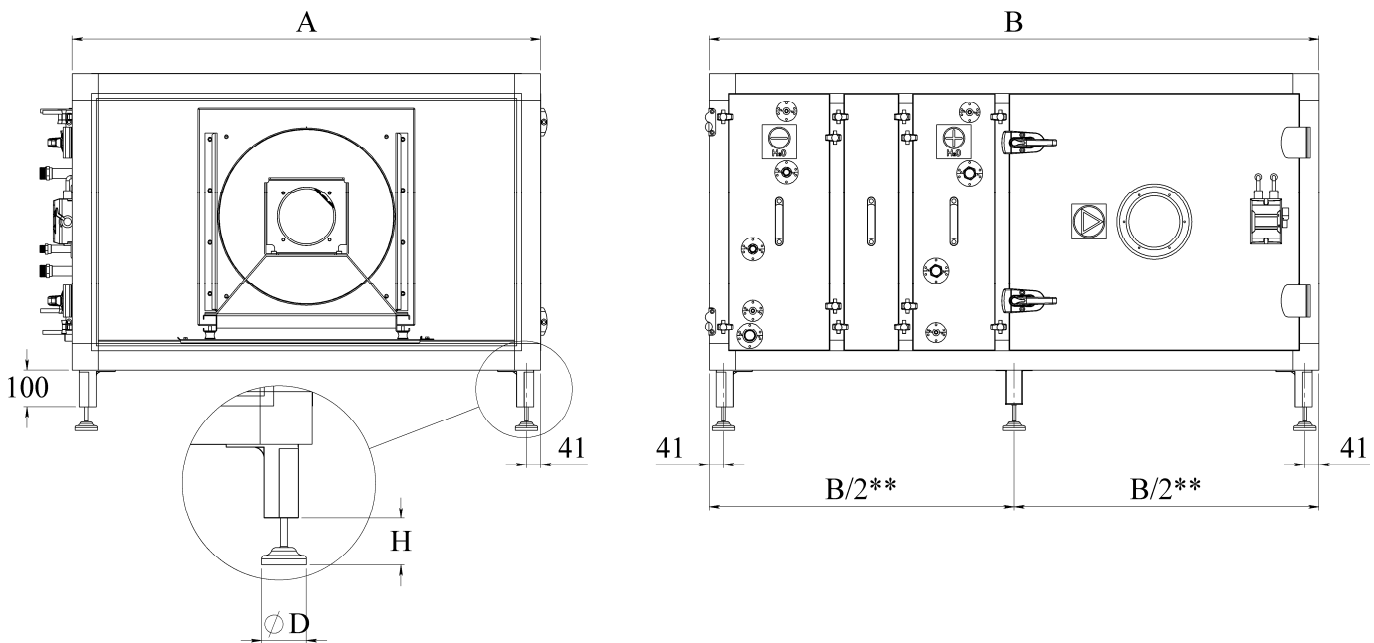

Figure 8.1.2.1 - AHU section with base frame type 2.

A – AHU width, mm, B – AHU section length, mm, \*\* - opening for additional centre support if B  $\geq$  1700mm.

Base frame type 2 can be adjustable or not adjustable. Adjustable base frame has same types of supporting foots as base frame type 1 already described in 8.1.1.

## 8.2. Sound attenuator

### Description:

1. Attenuator section designed to reduce generated by AHU fans noise level in the system.
2. Attenuator casing made of galvanized steel sheet, AluZn 185 steel sheet, AISI 304 steel sheet or AISI 316 steel sheet.
3. Cavity of baffle filled with sound-absorbent mineral wool.
4. Sound attenuators available as removable baffles inside casing (Figure 8.2.1) or as ductworks attenuators (Figure 8.2.2).
5. A maximum of 90% RH is allowed before each silencer section for hygienic units.

### Maintenance and cleaning:

1. Maintenance interval in accordance with the degree of contamination of the sound attenuator (at least 3 months).
2. Clean baffles with brush or vacuum cleaner.

### Sound attenuator section dismantling:

1. Stop the AHU before dismantling.
2. Release panel blocks 1.
3. Take off removable panel 2.
4. Take out separators 3 and baffles 4.
5. The sound attenuator mounted conversely to dismantlement sequence.

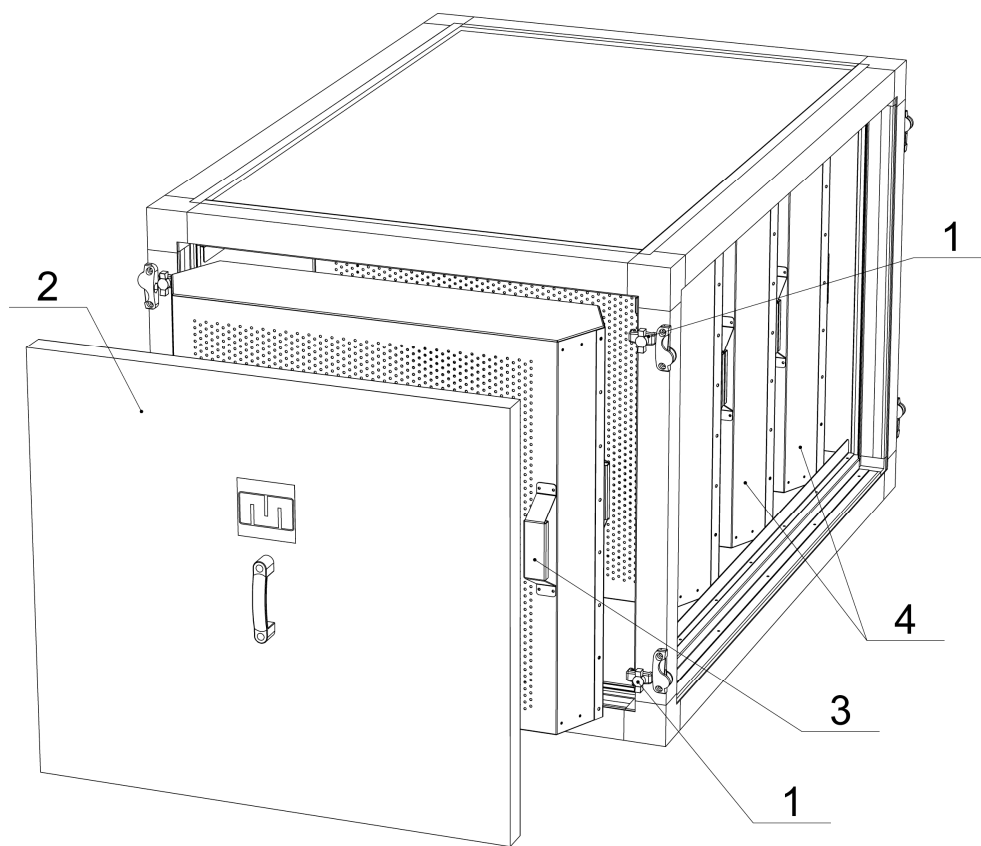

Figure 8.2.1 - Sound attenuator section.

1 – Panel blocks, 2 – removable panel, 3 – baffle handle, 4 – attenuators.

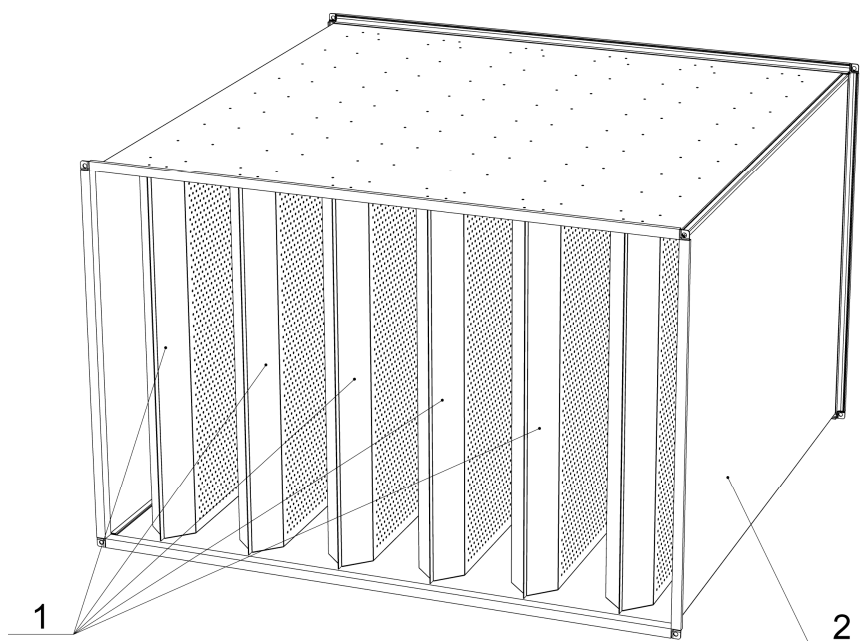

Figure 8.2.2 - Duct sound attenuator.

1 – Sound attenuator, 2 – duct.

### 8.3. Flexible connection

#### Description:

Flexible connection (Figure 8.3.1) used to connect air handling unit with duct system. It protects duct system from vibration generated by fan. Produced with E type connection (1). Use C type profile to connect flexible connection with damper or duct system and screws to connect with AHU.

#### Maintenance and cleaning:

1. Maintenance interval in accordance with the degree of contamination of the flexible connection (at least 3 months).
2. Check flexible connection for tightness between duct system and air handling unit during maintenance work.
3. Clean flexible connection with vacuum cleaner, do not damage flexible material 3 while cleaning.
4. Damages flexible connection leads to breakdowns and danger from escaping transported medium and must be replaced. Unscrew screws or take off C type connection profile for flexible connection replacement.

#### Important:

Remove transport locks 3 before starting the unit.

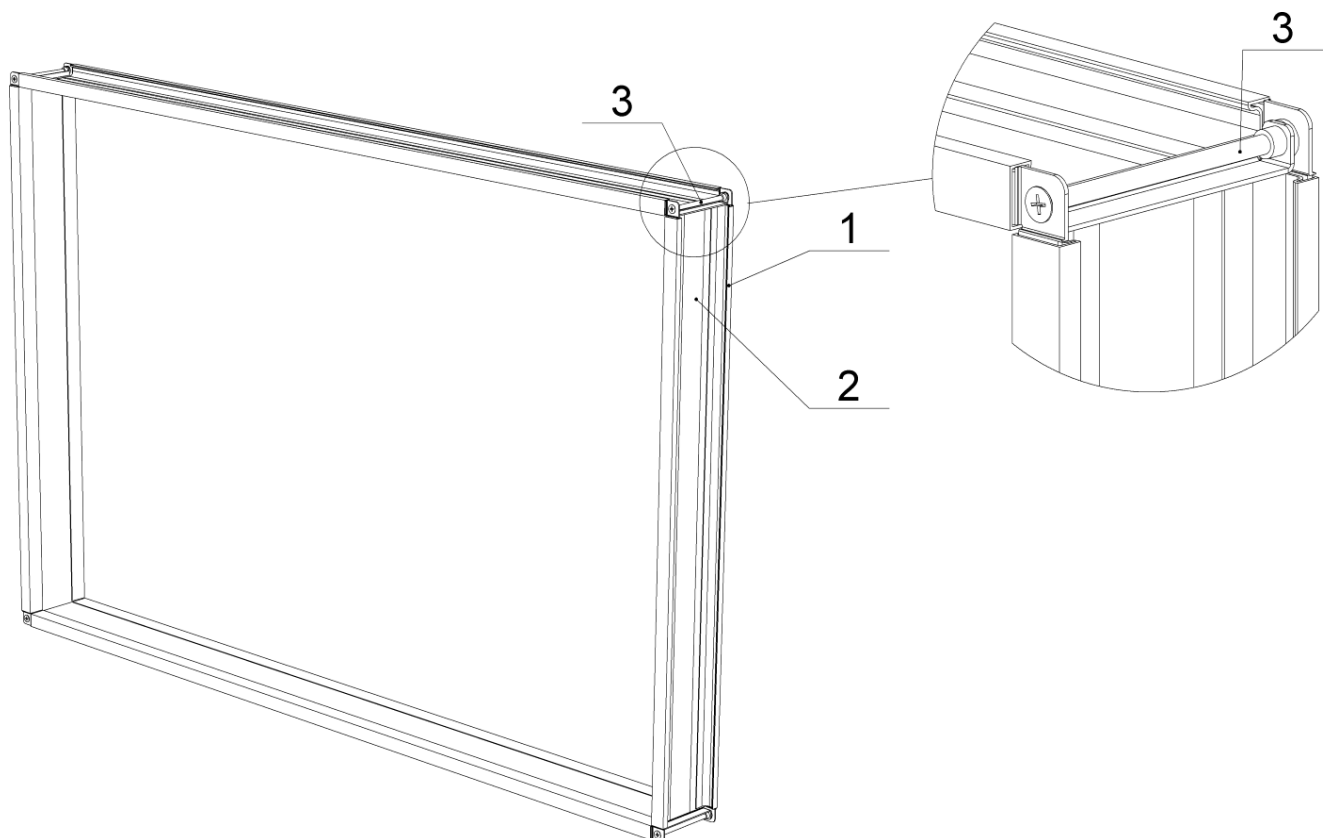

Figure 8.3.1 - Flexible connection.

1 – E type connection, 2 – flexible material, 3 – transport lock.

#### 8.4. Outdoor grille

Outdoor grille used to protect outdoor air section from precipitation and foreign objects (e.g. leaves). The grille is made from aluminium profiles.

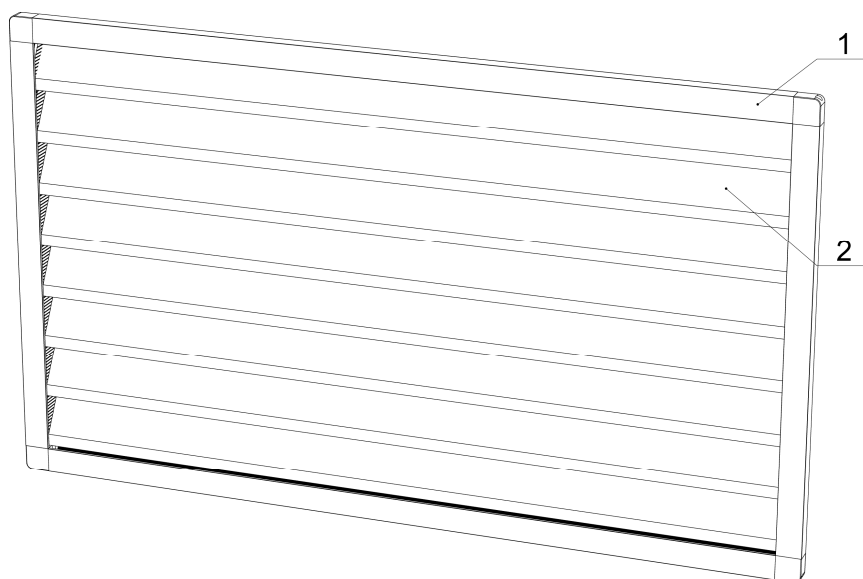

Figure 8.4.1 - Outdoor grille.  
1 – Grille frame, 2 – grille blades.

#### 8.5. Hood with net

Hood with net used to protect exhaust air section from precipitation and foreign objects. Made from galvanized steel sheet or AluZn 185 steel sheet with net.

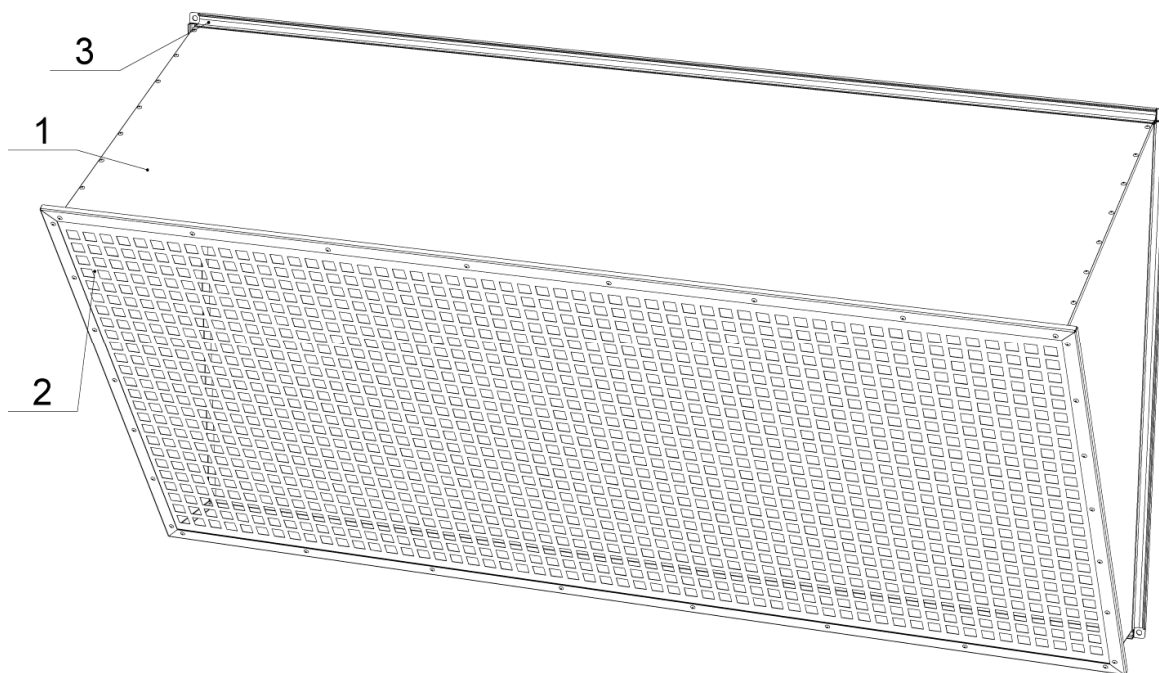

Figure 8.5.1 - Hood with net.  
1 – Frame, 2 – net, 3 – connection.

## 8.6. Roof

### Description:

Roof used to protect unit from precipitation.

Single slope roof are available for outdoor AHU sizes 1-10-KR, 12-13-KR.

Double slope roof are available for outdoor AHU sizes 11-KR, 14-16-KR.

### Assembling:

1. Fix roof guiding profiles 1 to AHU roof with self-screws (Figure 8.6.1 or Figure 8.6.3). The pitch of guiding profiles 1 for roof with single slope must be opposite directed to the maintenance side of AHU.
2. Fix roof segments 2 to the guiding profiles 1 using self-screws and rubber washers supplied with the unit (Figure 8.6.2 or Figure 8.6.4).
3. If air damper 4 or duct is above lower section of AHU as shown in Figure 8.6.2 or Figure 8.6.4, it can be a problem to fix roof with guiding profiles 1. In such a case fix roof segments 2 directly to the AHU roof with self-screws and rubber washers.
4. Join roof segments with C profiles supplied with the unit.

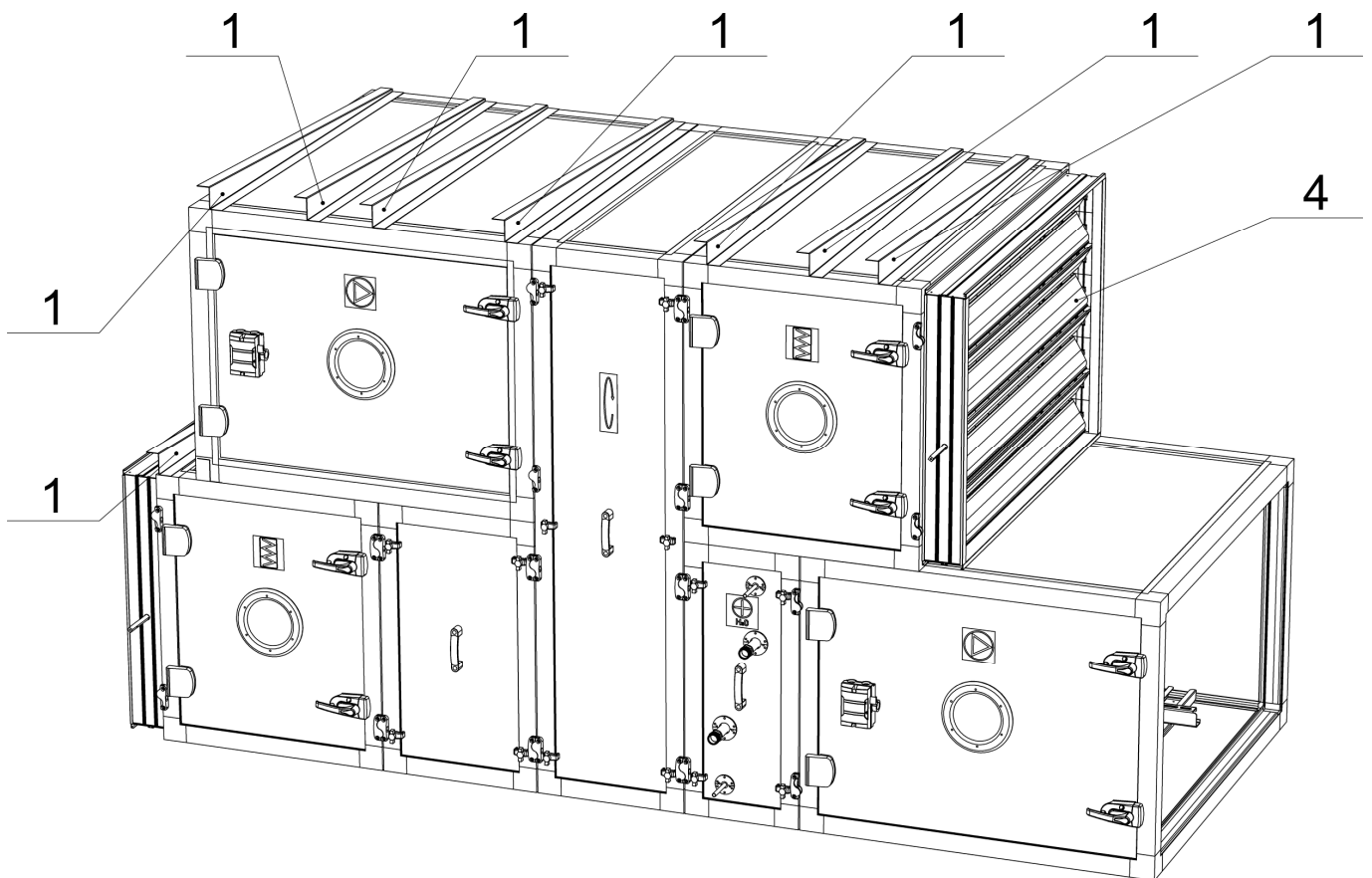

Figure 8.6.1 - Roof assembly with single slope. Step 1.

1 – Guiding profiles, 4 – damper.



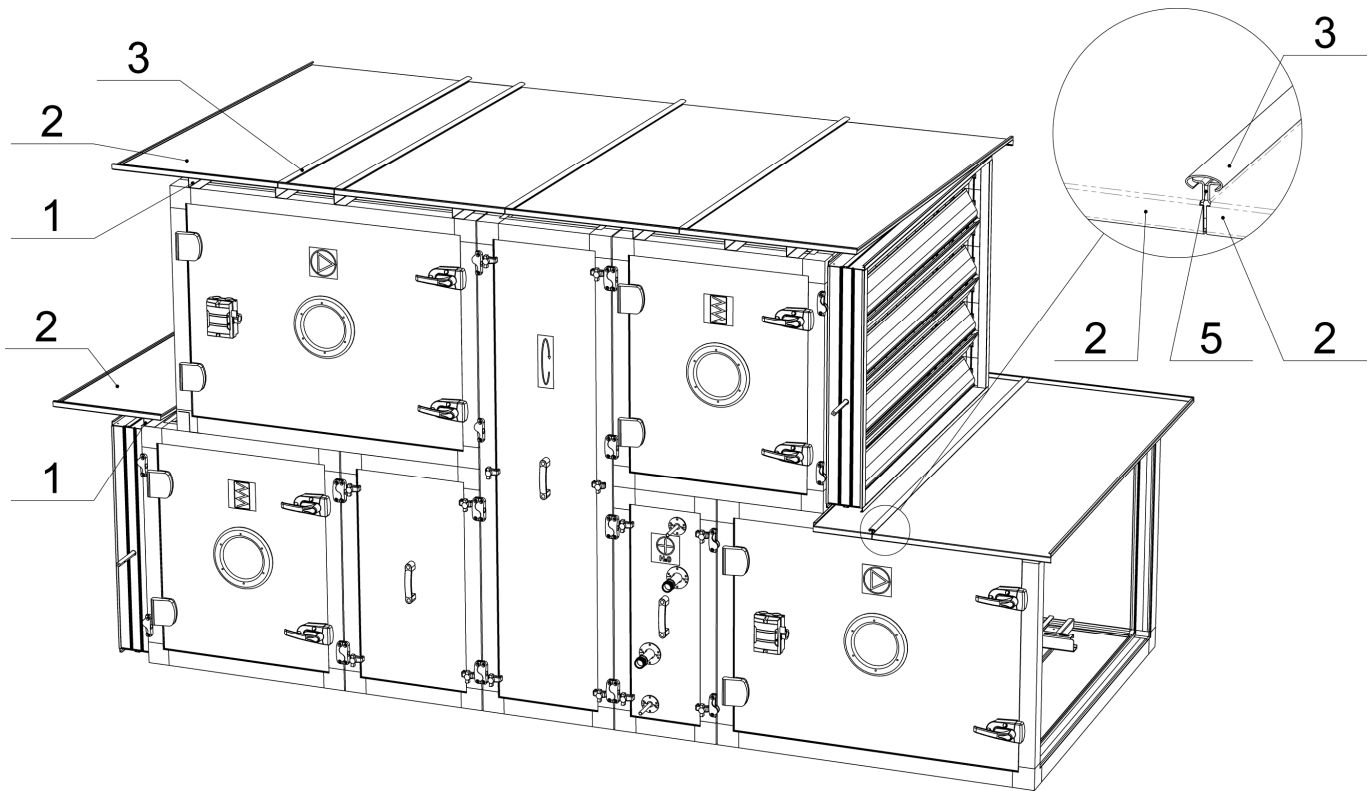

Figure 8.6.2 - Roof assembly with single slope. Step 2.

1 – Guiding profiles, 2 – roof segment, 3 – C profile connection, 5 – sealing strip.

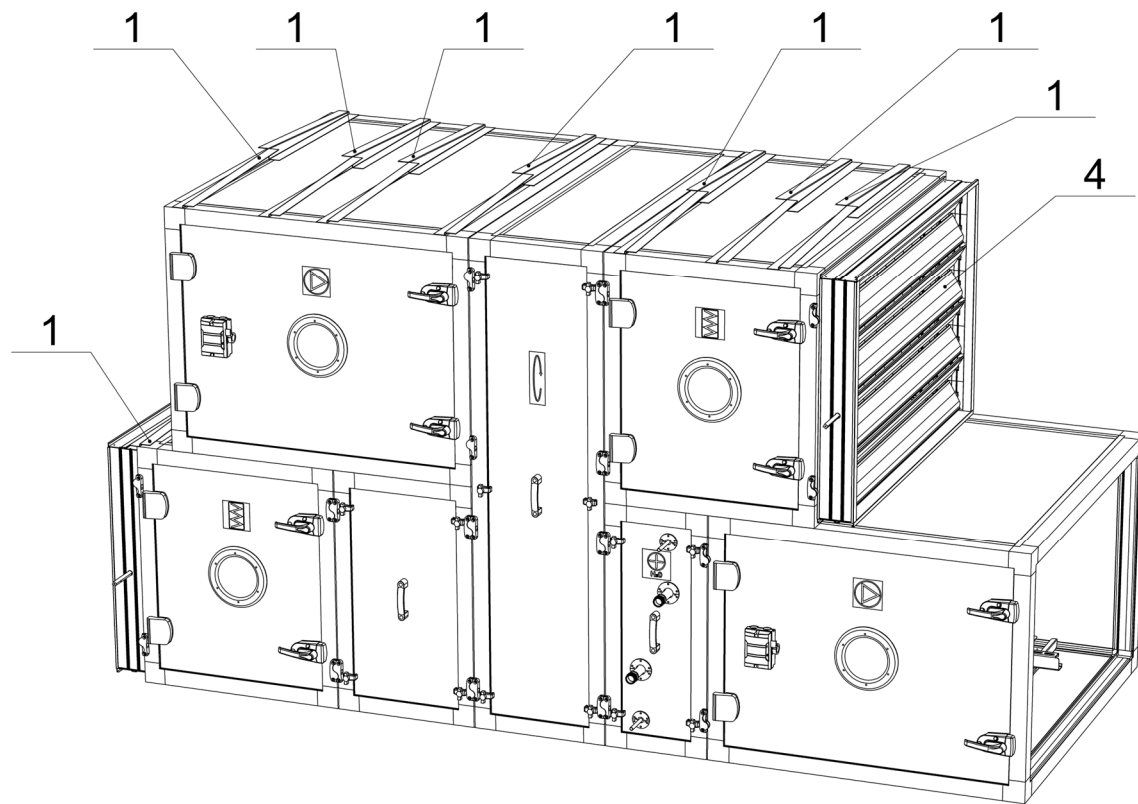

Figure 8.6.3 - Roof assembly with double slope. Step 1.

1 – Guiding profiles, 4 – damper.



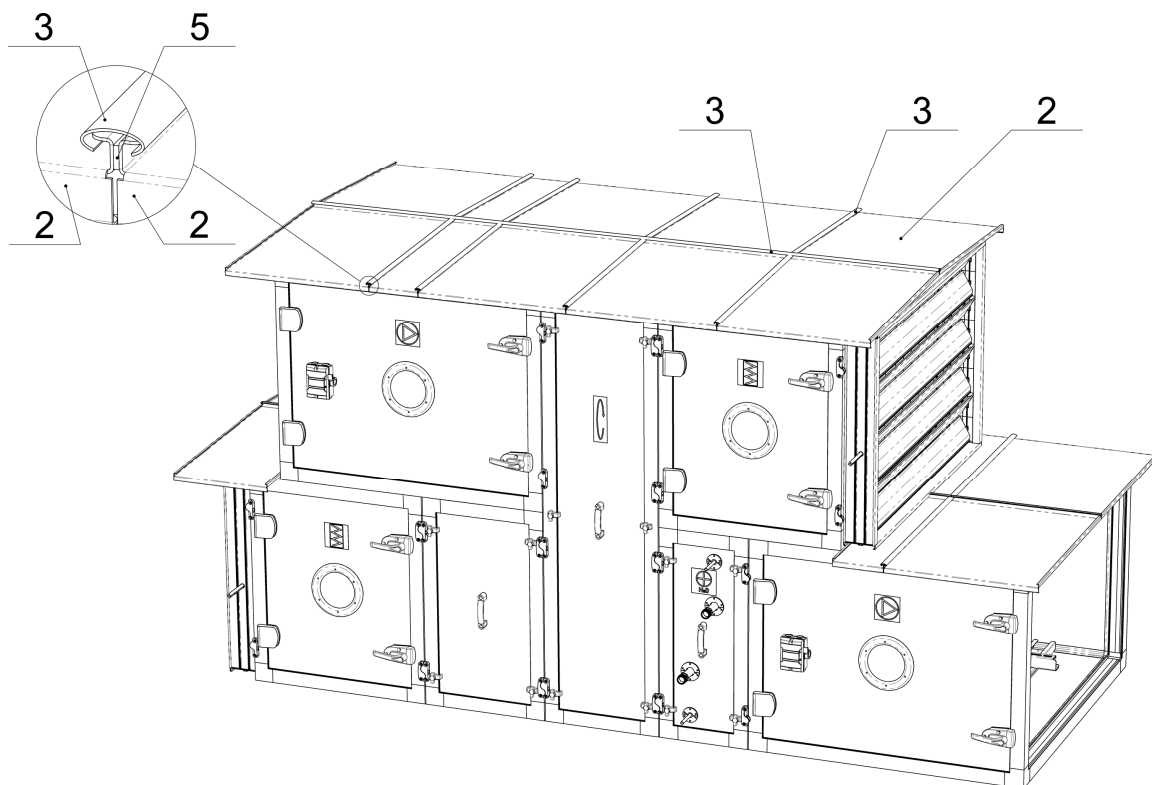

Figure 8.6.4 - Roof assembly with double slope. Step 2.

1 – Guiding profiles, 2 – roof segment, 3 – C profile connection, 5 – sealing strip,

### 8.7. Inspection window

Inspection windows used in air handling units when visual inspection (when unit is not opened, stopped) of inner components is needed. Optional component for filters section (to check if filters are not contaminated), fan section (to check if fan works properly), humidifier and service section.

Outdoor design unit's inspection window has cover to protect inner components from sunlight.

Fan sections with interior height from 1.6m and more always have inspection windows.

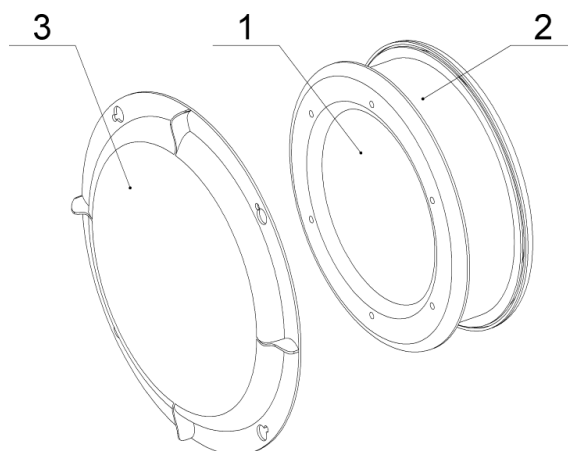

Figure 8.7.1 - Inspection window.

1 – Inspection window, 2 – rubber sealing, 3 – protection cover.

## 8.8. Lighting

8W LED bulb lamp lighting optionally can be installed inside some sections (e.g. fans, filters). Lighting switch installed outside the section.

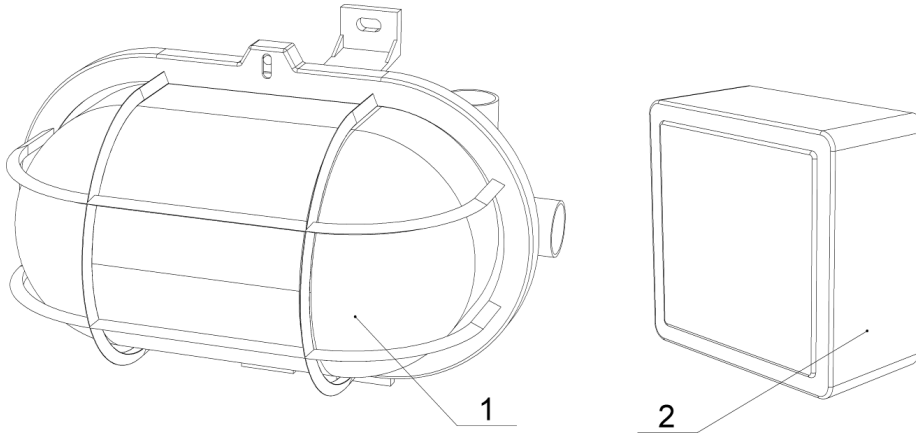

Figure 8.8.1 - Lighting.

1 – Lighting, 2 – switch.

## 8.9. Pressure taps

Pressure taps used to connect pressure-measuring devices and check pressure drop of the component during maintenance work. Pressure taps optionally can be ordered for water heater section, steam heater section, water cooler section, DX cooler section, evaporative humidifier section, counter-flow heat exchanger section, cross-flow heat exchanger section, rotary heat exchanger section, rotary heat exchanger with heat pump section and heat recovery coil sections. Number of pressure taps depends on section type.

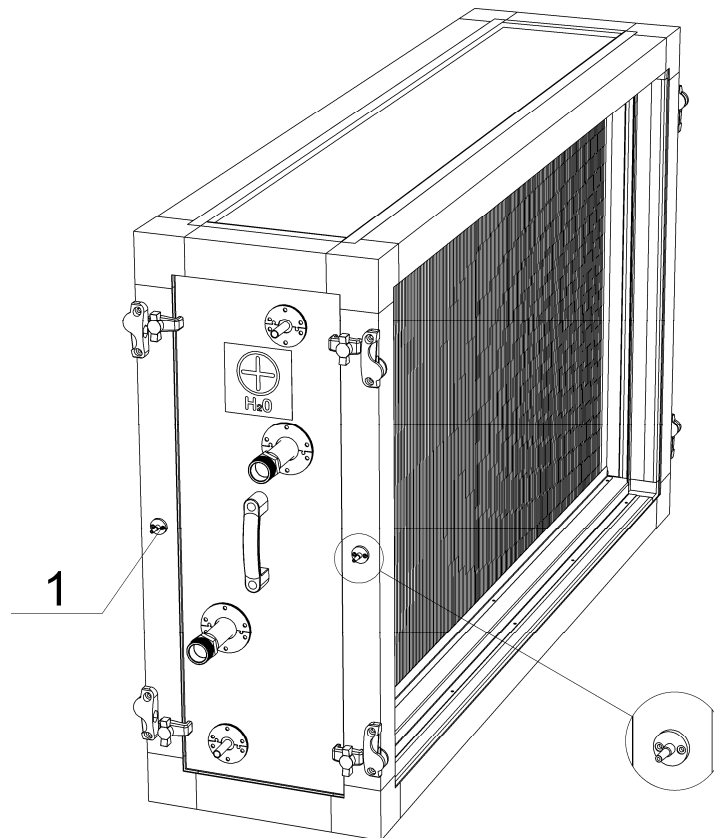
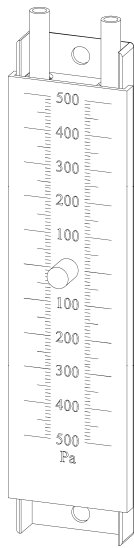

Figure 8.9.1. Pressure taps  
1 – Pressure tap.

## 8.10. Filter contamination control accessories

Different types of filter contamination control which can be selected within selection software for filter sections shown in the following figure.



A

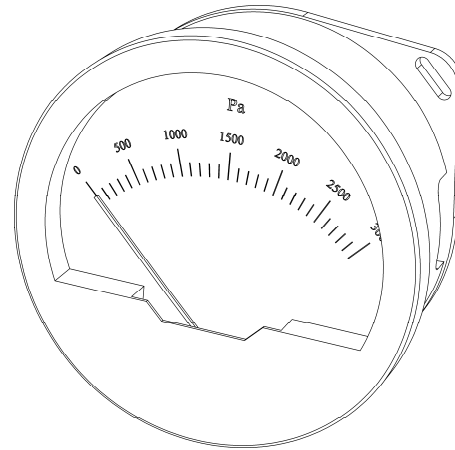

B



C



D



E

Figure 8.10.1 – Filter contamination control.

A - U-tube manometer, B - Pressure gauge, C - Pressure relay, D - Pressure transmitter, E - Pressure transmitter with display

## 9. Usage

### 9.1. Delivery

Air handling unit is delivered in separate sections. In case of transportation limits or restricted building accesses some sections can be divided in parts. Refer to separate manuals for instructions how to assemble such sections.

All surfaces of each section which are in contact with air stream cleaned and particles removed after manufacture with vacuum cleaner.

Fully completed section is set on a wooden palette, which protects the section from strain. Units are delivered with protective film to protect the product from dirt and water during shipping.

When the unit is delivered, it must be checked for damage and completeness in the presence of the lorry driver. Missing parts or damage should be documented immediately in the shipping order and reported to SALDA office.

If the contents of the unit is damaged, report the damage to SALDA office in writing together with photos of damaged parts after you established the extent of the damage. Possible shipping damage must be reported to SALDA office within five working days after delivery.

### 9.2. Loading, unloading and transportation

#### Important:

1. Make sure that before transportation the unit section is fastened correctly and does not move in the truck. If the unit section is not constrained, severe damage can occur during transportation.
2. For transporting use the original packing only. Remove the packing from the unit section before installation only.
3. For safety reasons wear gloves and safety footwear during unloading and transportation of the unit.
4. All sections are supplied on wooden pallets. Unloading and transporting should preferably be carried out with a crane or a fork-lift truck.
5. Before transporting the section, make sure that all doors, dampers and panels are closed and secured. Never use damaged lifting equipment or equipment with insufficient load-bearing capacity. Do not use ropes that are knotted or exposed to sharp edges. Handle units with care, without jerky movements. Do not set the unit down abruptly.

#### Caution:

Do not stand under an airborne load due to the risk that the lifting equipment could break. Death, serious injury or material damage may be caused by falling objects if safety precautions will not be followed.

#### 9.2.1. Unloading unit sections by crane using lifting bars

##### Attention:

Only use suitable and approved slinging devices (ropes, chains or lifting belts) for unloading and transporting the unit sections.

##### Unloading section using lifting bars:

1. Lifting bars (not provided by SALDA) are used together with base frame of the section.
2. If the section is supplied without base frame it must be lifted together with wooden palette.

3. The lifting bar should be a tube of  $\text{Ø}50\text{mm}$  with a stop at both ends, so that the lifting straps won't slip off while lifting is in progress.
4. Use the hoist (not provided by SALDA) as illustrated.
5. Timber spacers (not provided by SALDA) must be used to protect the edges of the section.
6. Suspension angle must not exceed  $80^\circ$ .
7. No additional loads should be lifted together with the section.
8. When installing units outdoors, particular care should be taken to ensure that the roof sheeting is not damaged by the hoists.
9. When lifting, pay attention to the centre of gravity in order to avoid slipping or tilting.

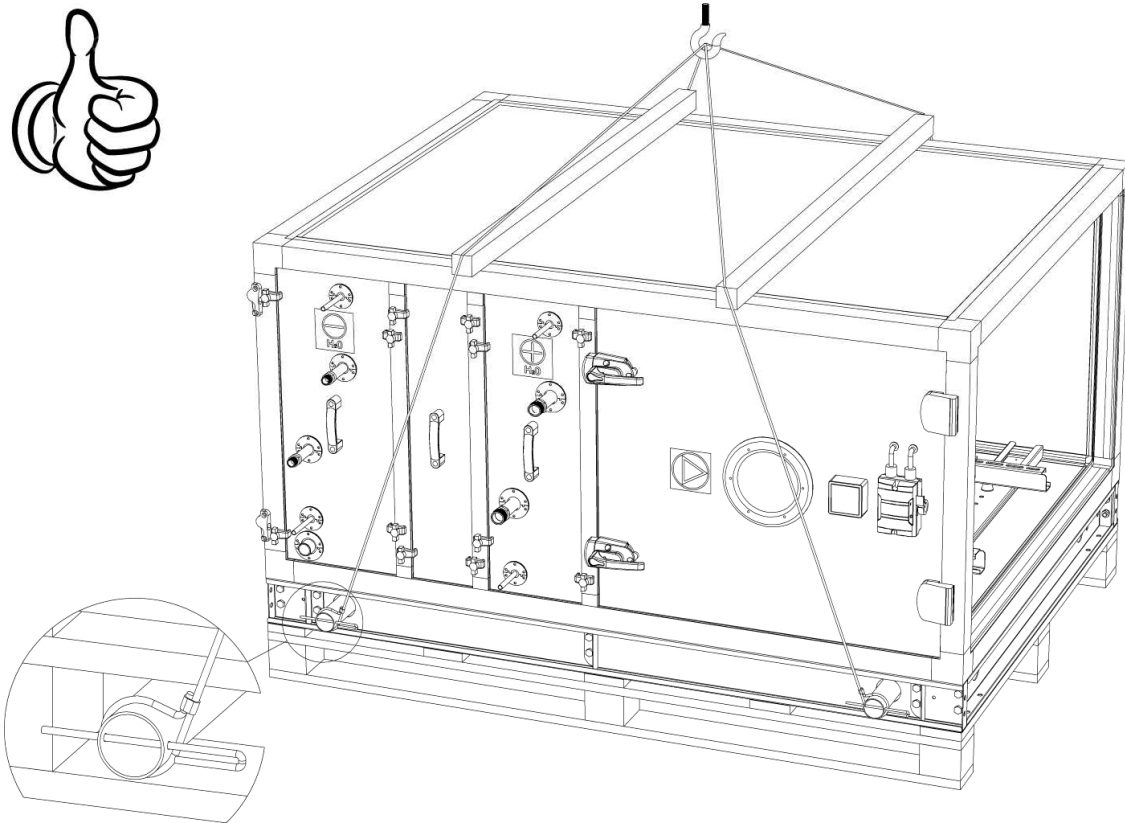

Figure 9.2.1.1 - Correct way of lifting AHU section with base frame using lifting bars

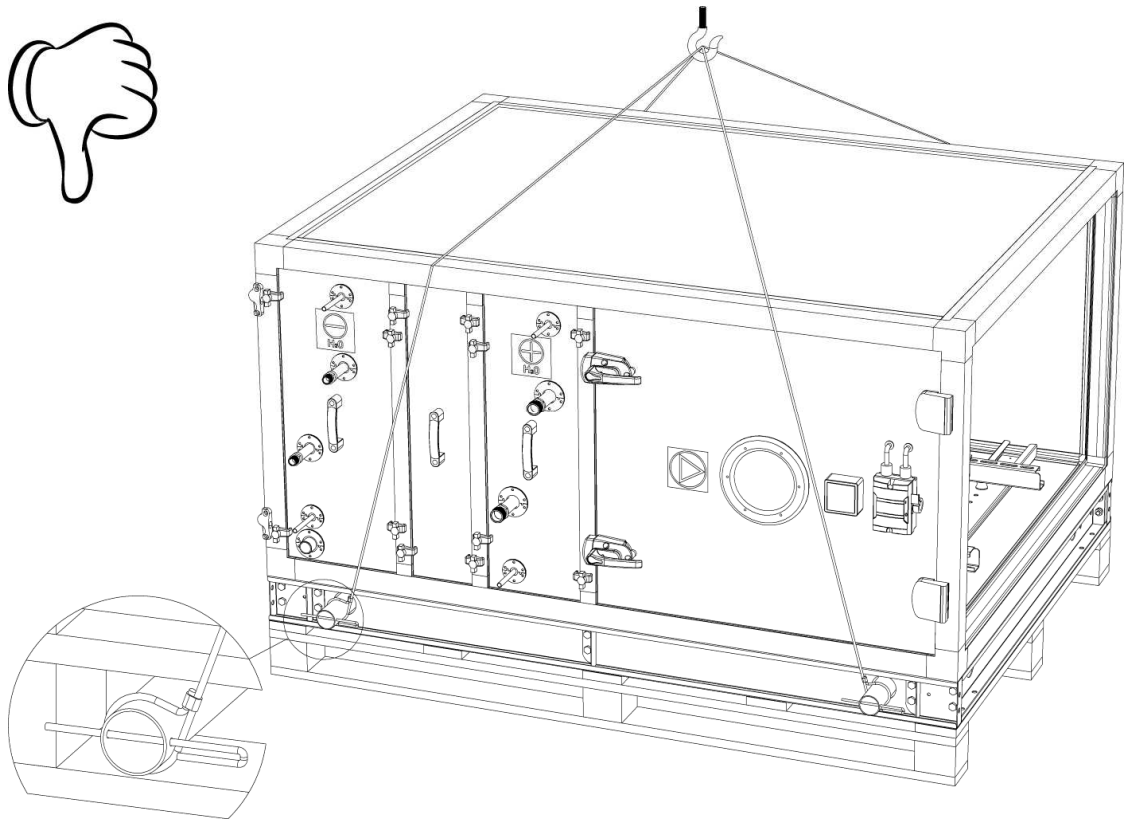

Figure 9.2.1.2 - Incorrect way of lifting AHU section with base frame using lifting bars (lack of timber spacers)

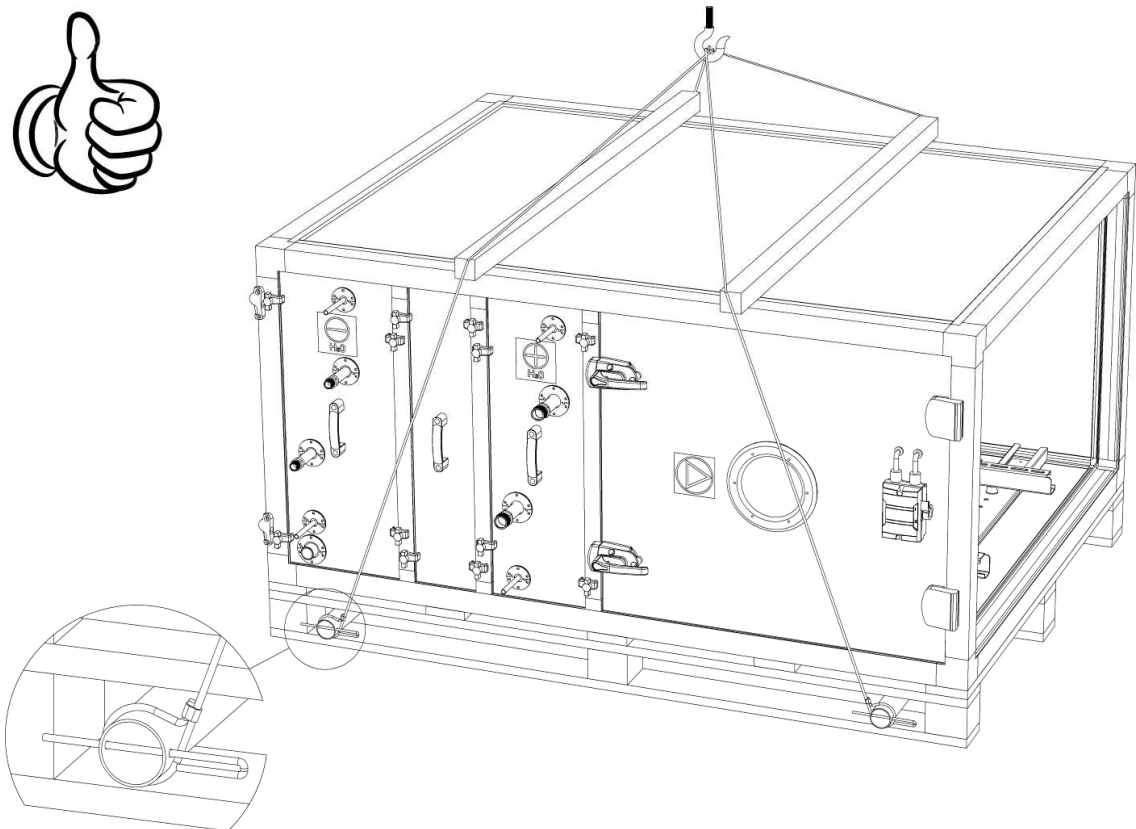

Figure 9.2.1.3 - Correct way of lifting AHU section without base frame using lifting bars



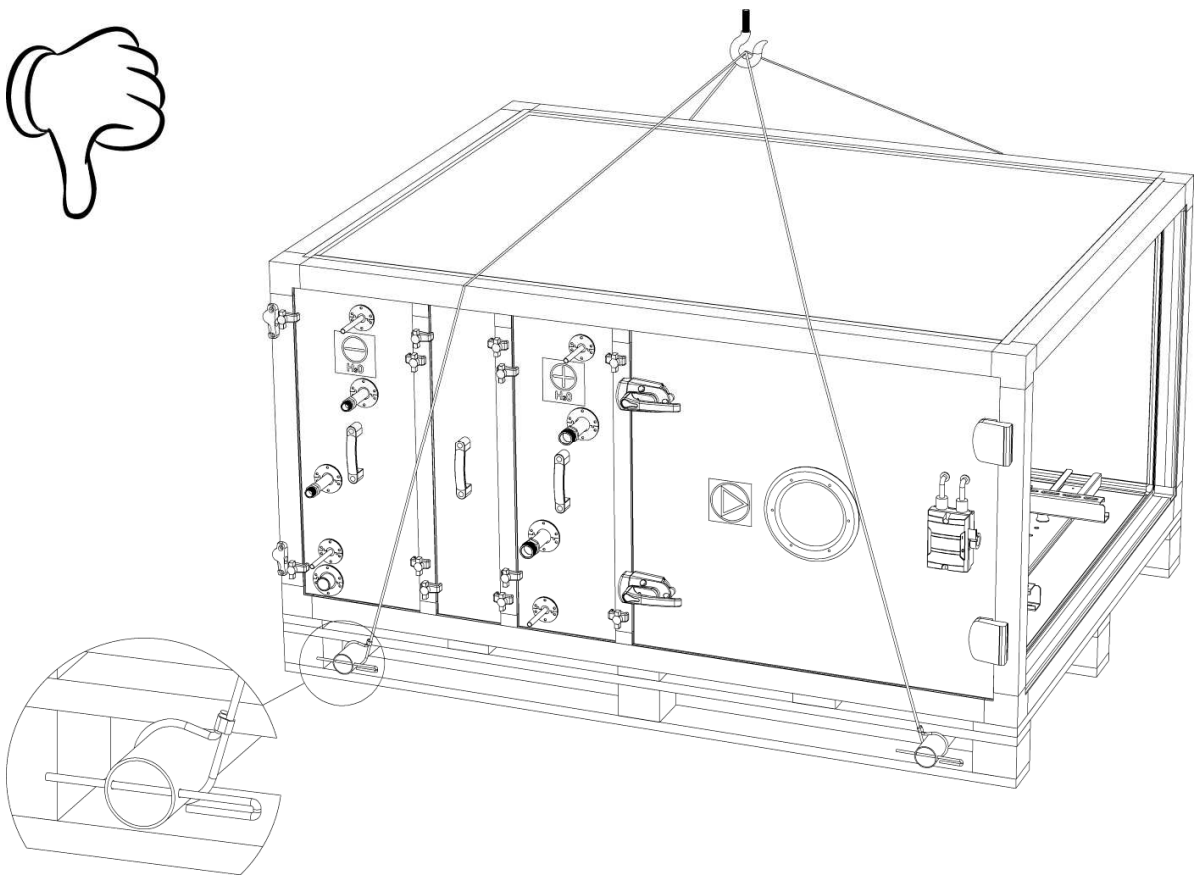

Figure 9.2.1.4 - Incorrect way of lifting AHU section without base frame using lifting bars (lack of timber spacers)

### 9.2.2. Unloading unit sections by crane using lifting loops

#### Unloading section using lifting loops (lifting loops available as option):

1. Only use lifting loops supplied by SALDA.
2. Use the hoist (not provided by SALDA) as illustrated.
3. Timber spacers (not provided by SALDA) must be used to protect the edges of the section.
4. Suspension angle must not exceed 80°.
5. No additional loads should be lifted together with the section.
6. When installing units outdoors, particular care should be taken to ensure that the roof sheeting is not damaged by the hoists.
7. When lifting, pay attention to the centre of gravity in order to avoid slipping or tilting.
8. Lifting loops may only be used once.



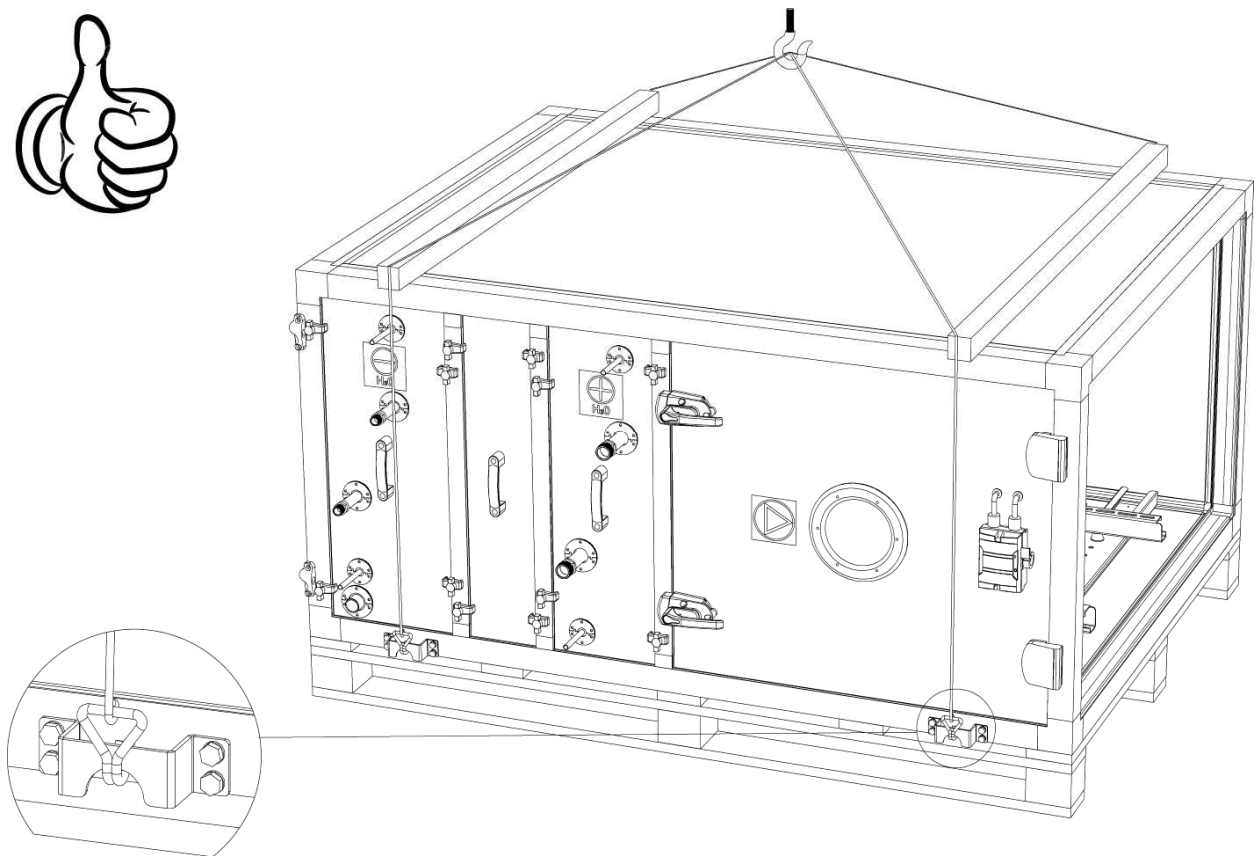

Figure 9.2.2.1 - Correct way of lifting AHU section using lifting loops

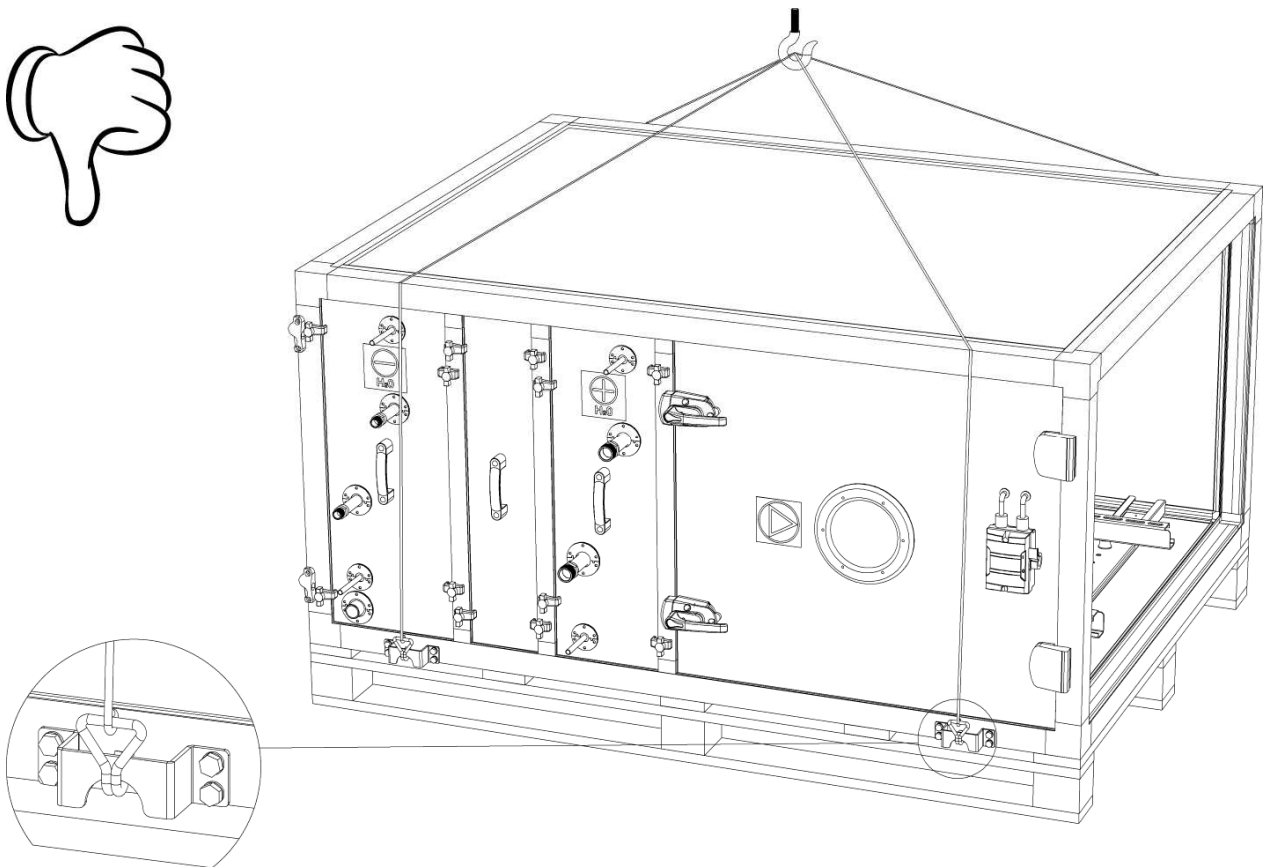
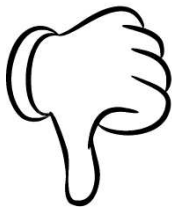

Figure 9.2.2.2 - Incorrect way of lifting AHU section using lifting loops (without timber spacers)

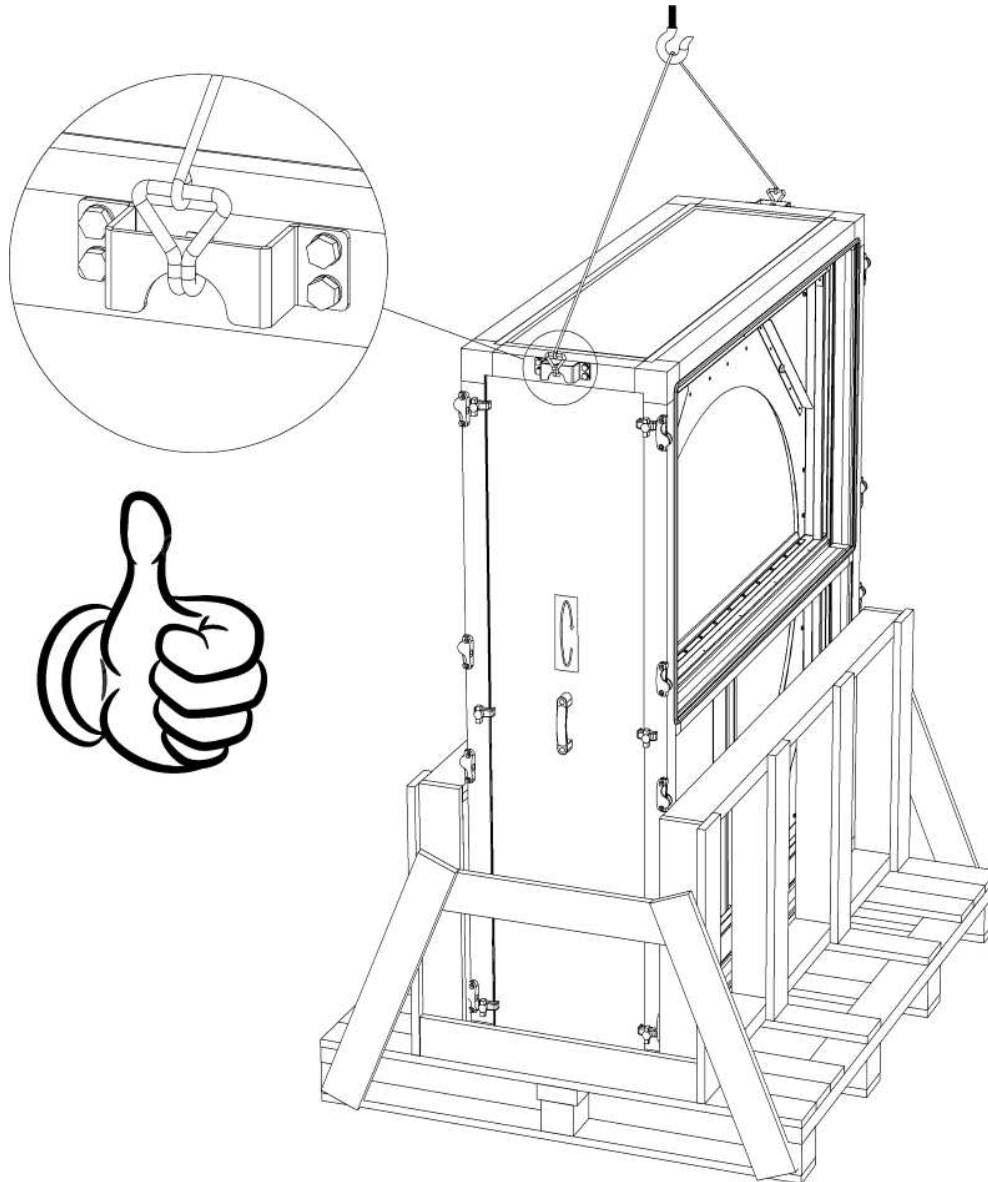

Figure 9.2.2.3 - Correct way of lifting rotary heat exchanger section using lifting loops

### 9.2.3. Unloading and transport unit sections by fork-lift truck

#### Attention:

When lifting and transporting the unit section with fork-lift truck, use forks which go fully underneath the unit section. Only transport sections on the base frame or on the wooden pallet (provided with the unit by SALDA) unless the section profiles are sufficiently protected.

#### Unloading and transport section by fork-lift truck:

1. When transporting by fork-lift truck, both base frame profiles of the section must be resting on the fork.
2. Never stack sections one on top of the other section for transportation. Exceptions are deliveries from SALDA factory, when adequate load-bearing capacity has been taken into account.

3. No additional loads should be lifted together with the section.
4. When lifting, pay attention to the centre of gravity in order to avoid slipping or tilting.

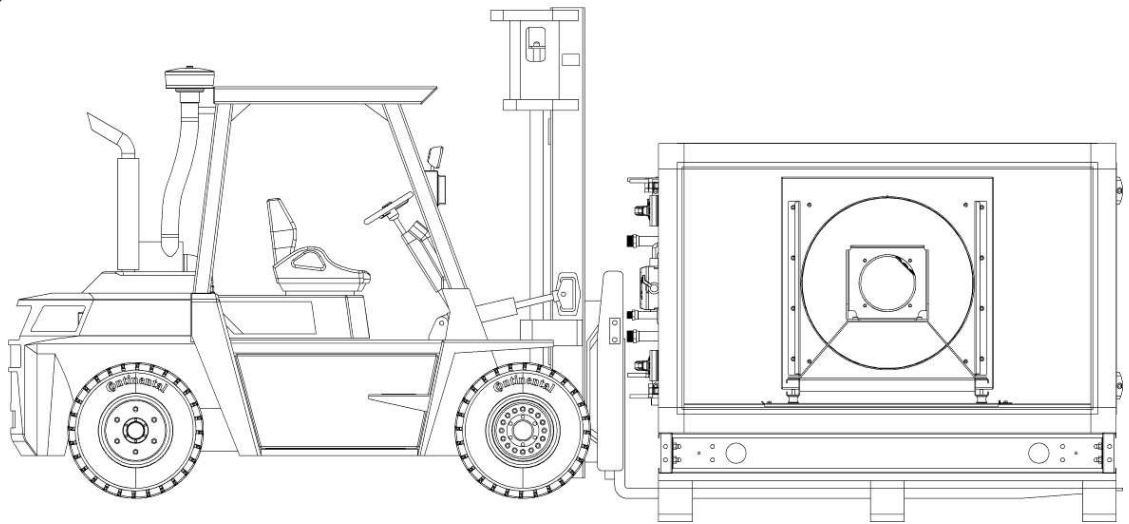

Figure 9.2.3.1 - Correct way of lifting AHU section with base frame by fork-lift truck.

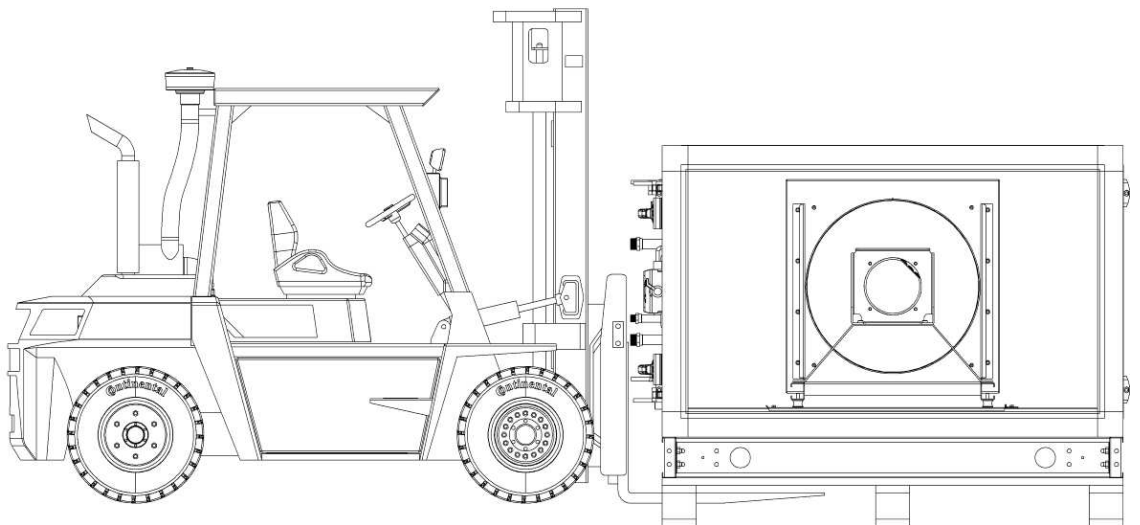
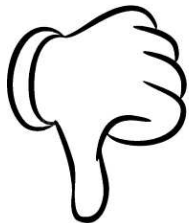

Figure 9.2.3.2 - Incorrect way of lifting AHU section with base frame by fork-lift truck (section is not laying on forks completely).

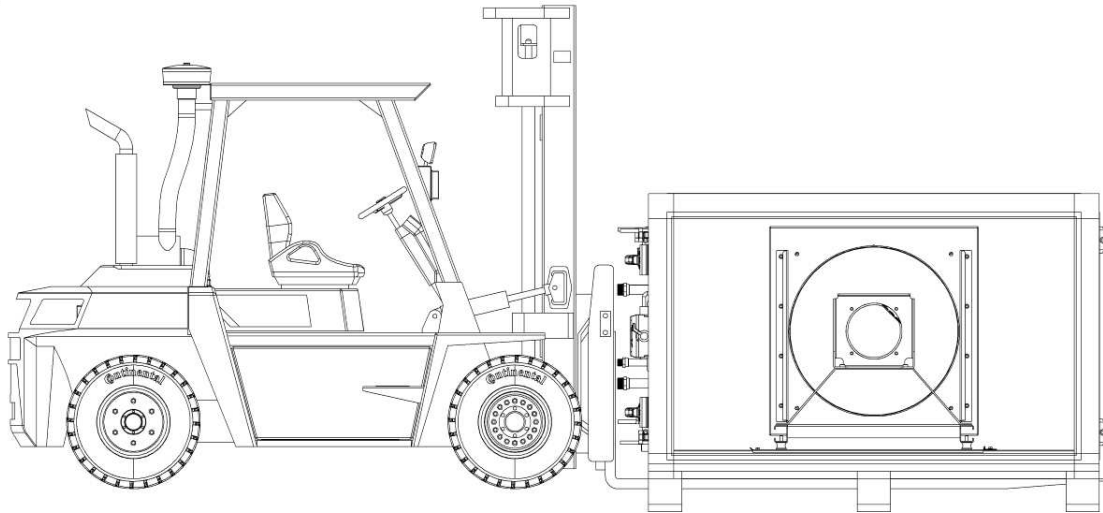

Figure 9.2.3.3 - Correct way of lifting AHU section without base frame.

### 9.3. Storage

Units are packed in the factory to comply needs of normal shipping. While unloading and storing the units, use suitable lifting equipment to avoid damages and injuries. Do not lift units by holding on power supply cables, connection boxes, air intake or discharge flanges. Avoid hits and shock overloads. Before installation units must be stored in a dry room with the relative air humidity not exceeding 70% (at +20° C) and with the average ambient temperature ranging between +5° C and +30° C. The place of storage must be protected against dirt and water. During the on-site storage every door, hatch and other type of openings (if applicable) shall be sealed. Avoid long term storage (period longer than 1 year is not recommended).

#### Attention:

Protective film is intended to protect the product during shipping. It is recommended to remove the protective film after the shipping, otherwise the product may get signs of oxidation.

## 9.4. Installation

### 9.4.1. Labelling

Each AHU section has a label with AHU name, date of manufacturing, serial number and section number.

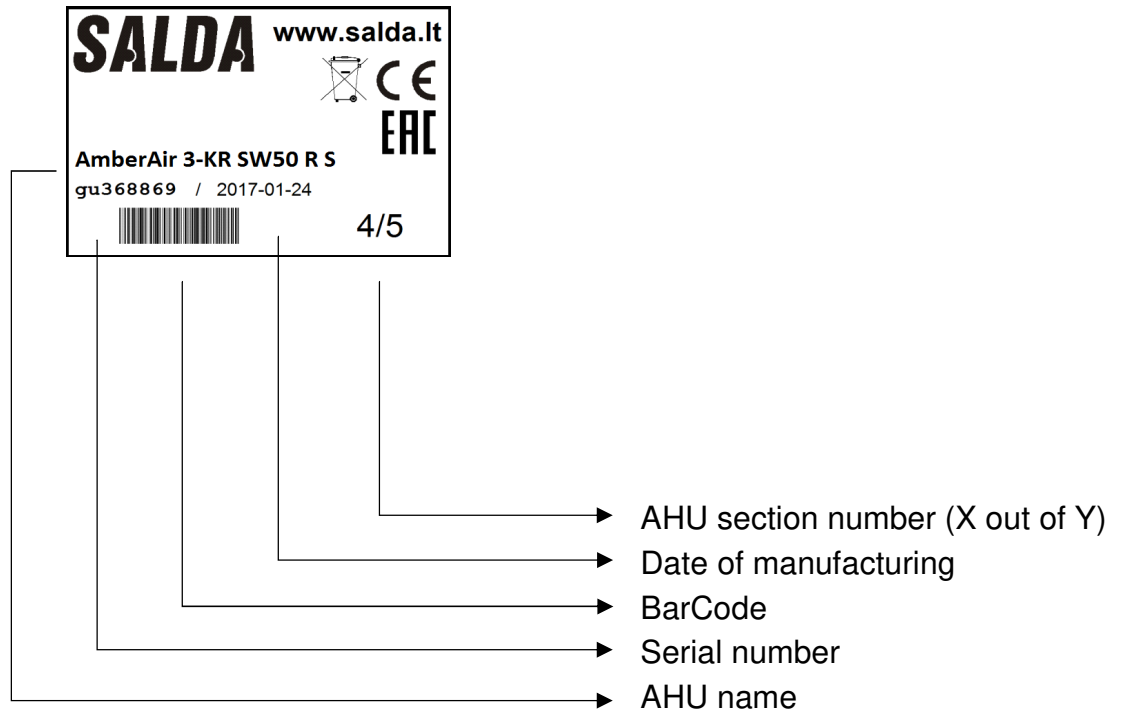

Additionally each component labelled with number that matches this component number on the drawing in the selection software printout. Please observe this information and connect the unit sections in correct order.

### 9.4.2. Maintenance side

1. Maintenance side is identified looking down from AHU's upside according the main air flow direction (Figure 9.4.2.1). The main air flow for the supply and heat recovery air handling units is a supply air flow and the main air flow for the exhaust air handling units is an exhaust air flow. For AHU with heat recovery coil the maintenance side is identified separately for supply and exhaust modules.
2. The connection side of water heater, cooler or drainage system tubes can be different from the AHU's maintenance side.
3. Recommended to leave the space in front of the unit for maintenance works. Leave at least space equal to one width of the unit to be able to change heating or cooling coil in case of its damage.
4. Recommended to leave at least 0.5m at the rear part of the unit for installation works.

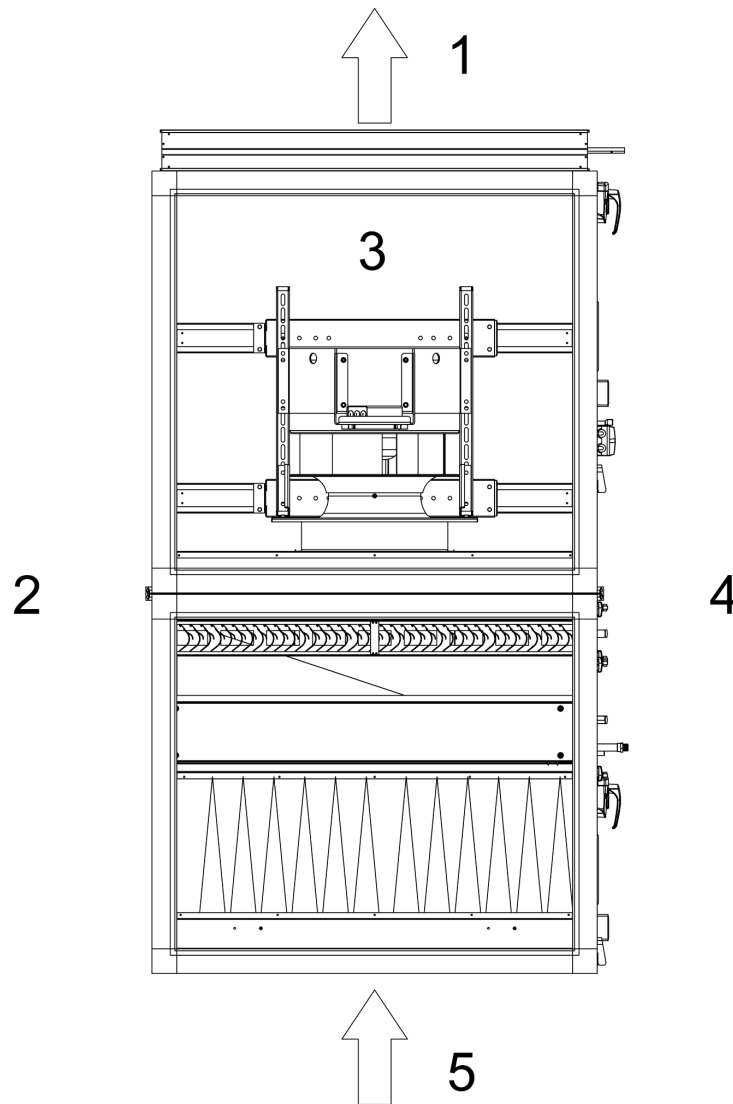

Figure 9.4.2.1 - Maintenance side of the unit.

1 – Main air flow direction, 2 – Left maintenance side, 3 – AHU Top view, 4 – right maintenance side, 5 – main air flow direction

### 9.4.3. Assembling

1. AHU with base frames fixed to sections (standard configuration):
  - 1.1. According to the AHU's drawing first floor sections with base frames are set out in the intended place leaving a 50cm gap between them.
  - 1.2. Apply the sealing strip between two sections (apply it only on one section, see 9.4.4). The sealing strip supplied with the unit.
  - 1.3. Lift up sections and screw vibration-proof foots to the base frames. The base level and smoothness should be secured if unit ordered without vibration-proof foots. Check sections using the level. Adjust the foots if necessary.
  - 1.4. Pull sections together and screw up using internal or external sections connection. External connection are selected with selection software by default. If the AHU is placed too close to a wall and there is no possibility to connect external connections, use internal connections. Please note that some sections might be difficult to connect with internal connections and another type of brackets (not provided by SALDA) might be required for permanent section connection. In case the unit with integrated control system the wire connections between the modules must be connected prior to connecting the unit sections.



- 1.5. Screw the base frames together.
  - 1.6. Lift up second floor sections on the first floor sections. Apply the sealing strip between two sections (apply it only on one section, see 9.4.4). Pull sections together and screw up them.
2. AHU ordered with base frames not fixed to sections / base frames not fixed to sections due to transportation height limits:
- 2.1. According to the AHU's drawing base frames are set out in the intended place. Number of the base frames depends on the configuration of the AHU.
  - 2.2. Screw vibration-proof foots to the base frames. The base level and smoothness should be secured if unit ordered without vibration-proof foots. Check base frames using the level. Adjust the foots if necessary.
  - 2.3. Screw the base frames together.
  - 2.4. Apply the sealing strip between two sections (apply it only on one section, see 9.4.4). The sealing strip supplied with the unit.
  - 2.5. Lift up first floor sections on base frames. Pull sections together and screw up using internal or external sections connection. External connection are selected with selection software by default. If the AHU is placed too close to a wall and there is no possibility to connect external connections, use internal connections. Please note that some sections might be difficult to connect with internal connections and another type of brackets (not provided by SALDA) might be required for permanent section connection. In case the unit with integrated control system the wire connections between the modules must be connected prior to connecting the unit sections.
  - 2.6. Screw the base frames to sections.
  - 2.7. Lift up second floor sections on the first floor sections. Apply the sealing strip between two sections (apply it only on one section, see 9.4.4). Pull sections together and screw up them.
3. AHU ordered without base frames:
- 3.1. According to the AHU's drawing first floor sections are set out in the intended place leaving a 50cm gap between them.
  - 3.2. Apply the sealing strip between two sections (apply it only on one section, see 9.4.4). The sealing strip supplied with the unit.
  - 3.3. Pull sections together and screw up using internal or external sections connection. External connection are selected with selection software by default. If the AHU is placed too close to a wall and there is no possibility to connect external connections, use internal connections. Please note that some sections might be difficult to connect with internal connections and another type of brackets (not provided by SALDA) might be required for permanent section connection. In case the unit with integrated control system the wire connections between the modules must be connected prior to connecting the unit sections.
  - 3.4. Lift up second floor sections on the first floor sections. Apply the sealing strip between two sections (apply it only on one section, see 9.4.4). Pull sections together and screw up them.
  - 3.5. The base level and smoothness should be secured for units without base frames.

Important:

1. Before installing the filters for units in hygienic design make final disinfection of the unit after assembling the sections together.

2. Check AHU using level after assembling the sections together. The AHU should be assembled horizontally otherwise it will be impossible to drain off water and bleed air from heaters or coolers, the condensate may stay in drip trays.

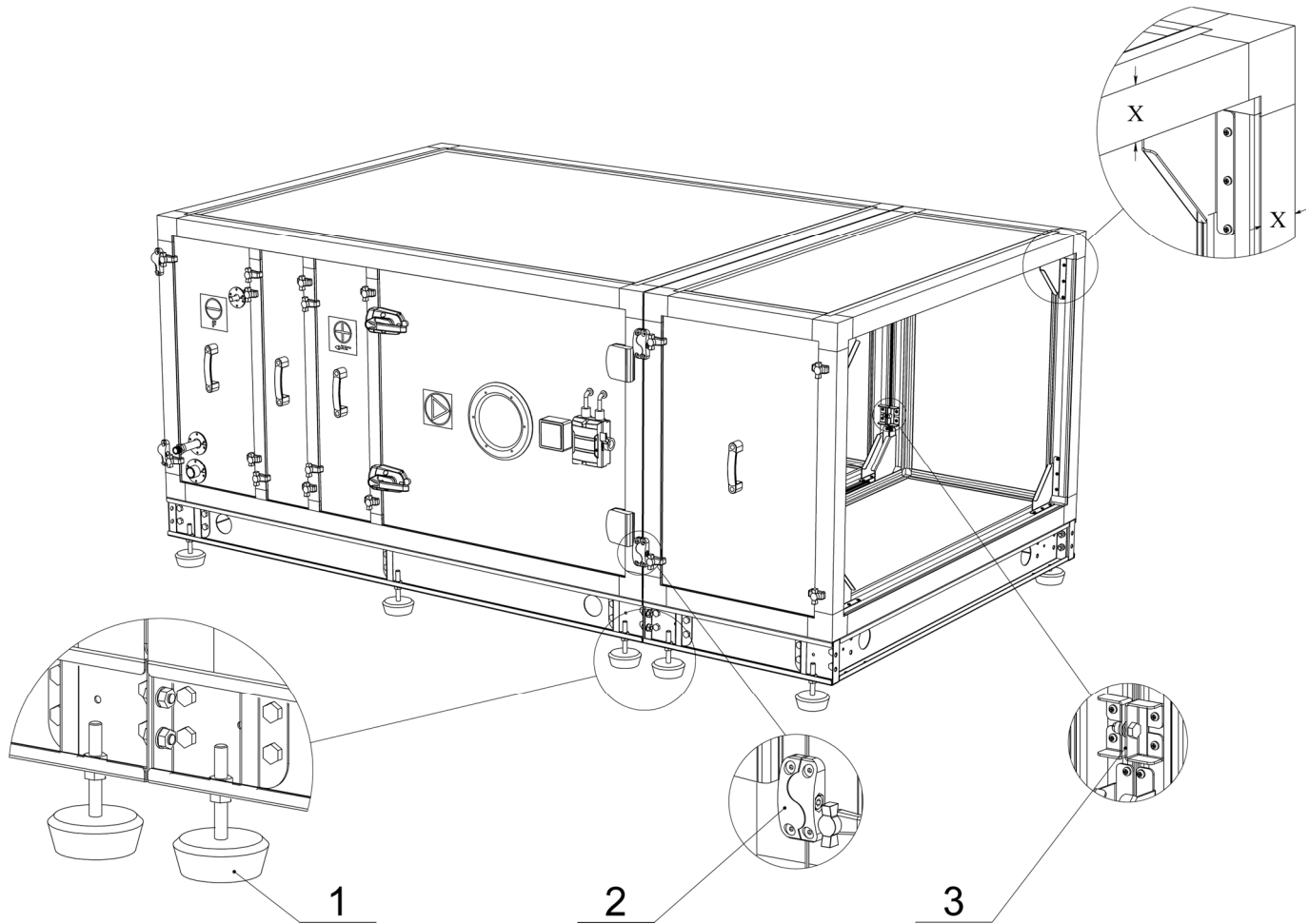

Figure 9.4.3.1 - Assembling.

1 – Vibration-proof foot, 2 – external connection, 3 – internal connection, x - aluminium profiles width:  $x=55.7\text{mm}$ .

Base level:

Flat base level is required for AHU installation. All unevenness, which might cause non-parallel frames of connecting parts, must be flattened before installation with adequate supports. The base level must conform to the building requirements in terms of statics, acoustics and proper water drainage.

9.4.4. Applying sealing strip on AmberAir units

Before screwing sections together, apply sealing strip between sections as shown in Figure 9.4.4.1 and Figure 9.4.4.2. Apply sealing strip only on one section. Apply sealing strip only on double deck section (undivided rotary heat exchanger section, plate heat exchanger section, undivided double-deck mixing section, etc.) when connecting double deck section with single deck section.



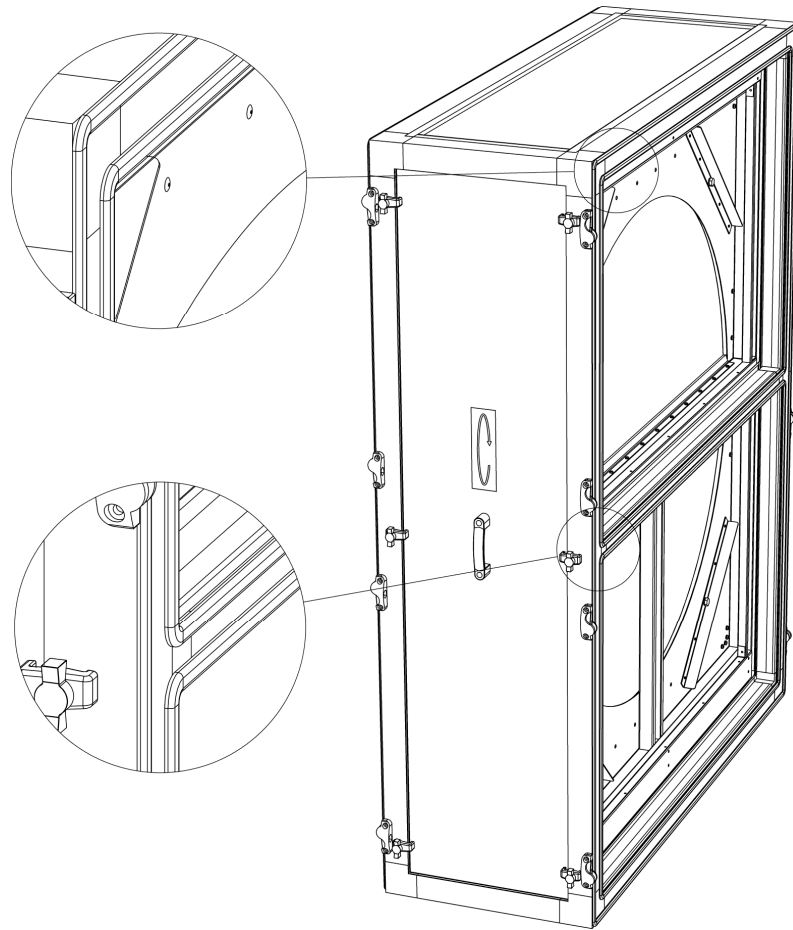

Figure 9.4.4.1 - Sealing strip on double deck AmberAir section.

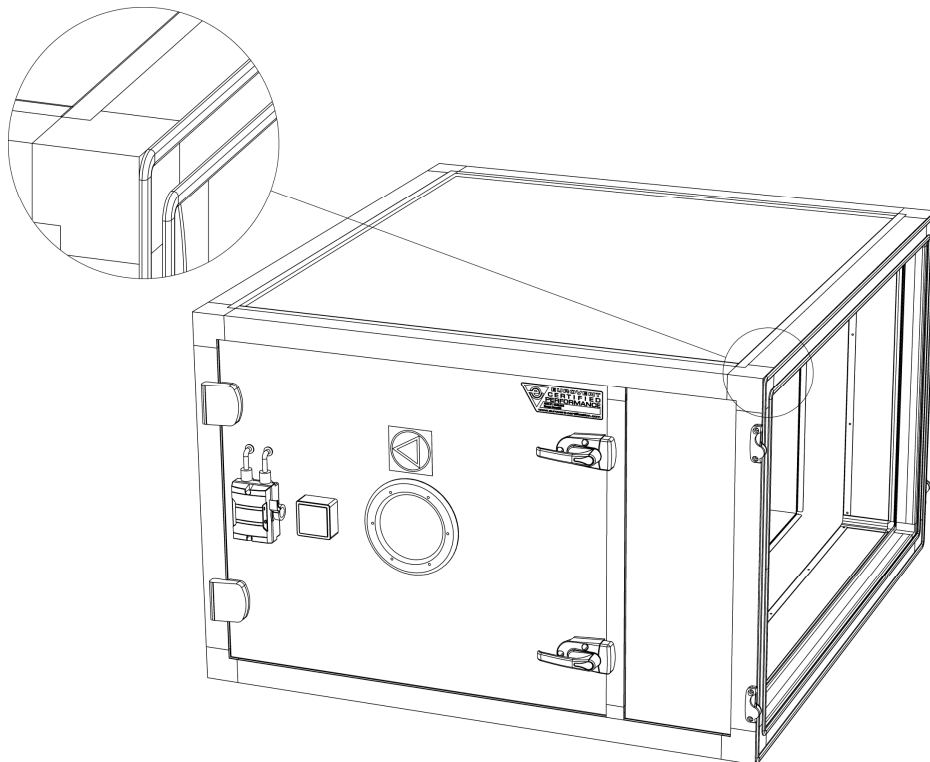

Figure 9.4.4.2 - Sealing strip on single deck AmberAir section.

### 9.4.5. Ceiling brackets

Ceiling brackets are used to hang AHU on the ceiling. Available as option until 4-KR unit size.

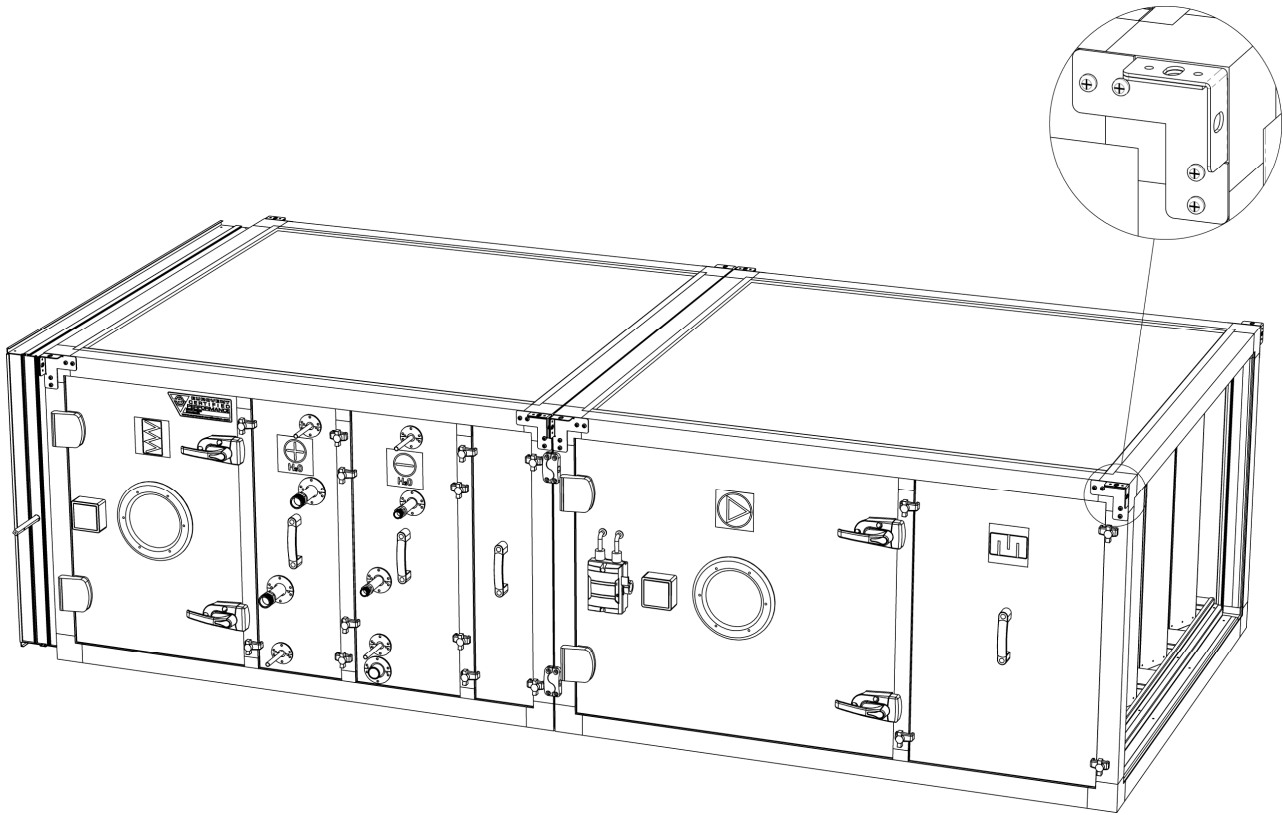

Figure 9.4.5.1 - AHU with ceiling brackets

### 9.4.6. Final disinfection

Final disinfection is recommended for all units after mounting the modules and connecting them together.

For Level 2 hygienic units final disinfection is mandatory after mounting the modules and connecting them together but before installing the filters.

## 9.5. Handles and hinges

### Description:

Access doors of AmberAir air handling units are equipped with a door handle with over-pressure protection. Refer to Figure 9.5.1 a) which shows handle in closed position. Locking mechanism of access panel is on the outer side of the unit.

### Door opening sequence (Figure 9.5.1):

1. In case door equipped with lockable handle – unlock it with supplied key before turn.
2. Turn handle 1 in direction 2 (Figure 9.5.1 b).
3. Pull handle in direction 3 (5 mm).
4. Turn handle in direction 4 (Figure 9.5.1 c).
5. Repeat steps 1-4 for other door handles if any.

6. Pull handle in direction 5 to open the access door (Figure 9.5.1 d).
7. Close door in the reverse sequence.

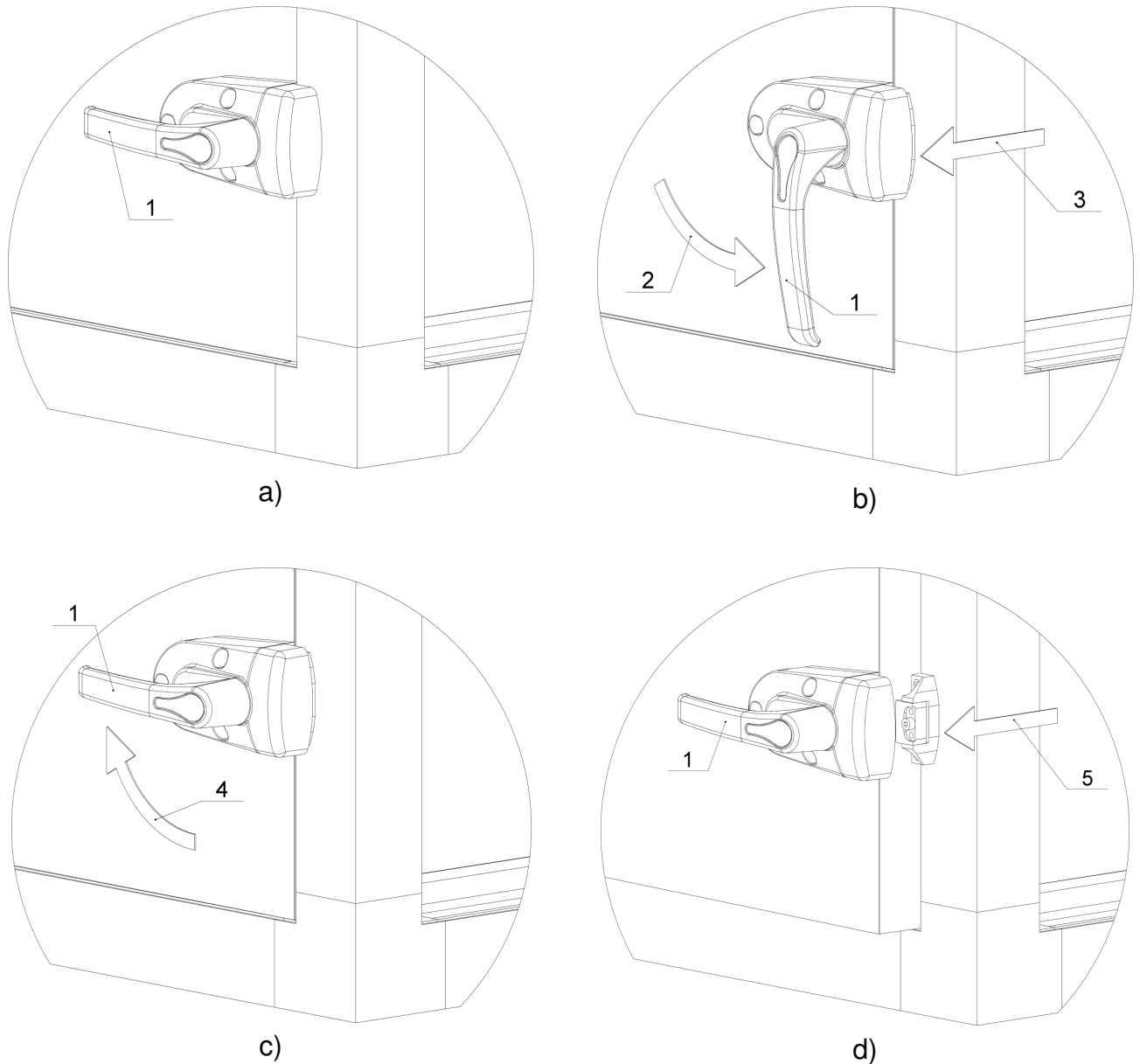

Figure 9.5.1 - AmberAir access door opening sequence.

**Important:**

After the complete assembly of the unit all access doors must be checked for freedom movement and, if necessary, aligned. Bolt torque: 3 Nm.

**Handle adjustment (Figure 9.5.2):**

1. Loosen three screws 1 (Figure 9.5.2 a).
2. Move handle sideways for horizontal alignment.
3. Tighten screws 1.
4. Loosen two screws 2 (Figure 9.5.2 b).
5. Move locking mechanism up or down for vertical alignment.

6. Tighten screws 2.
7. Turn screw 3 for the adjustment of locking mechanism.

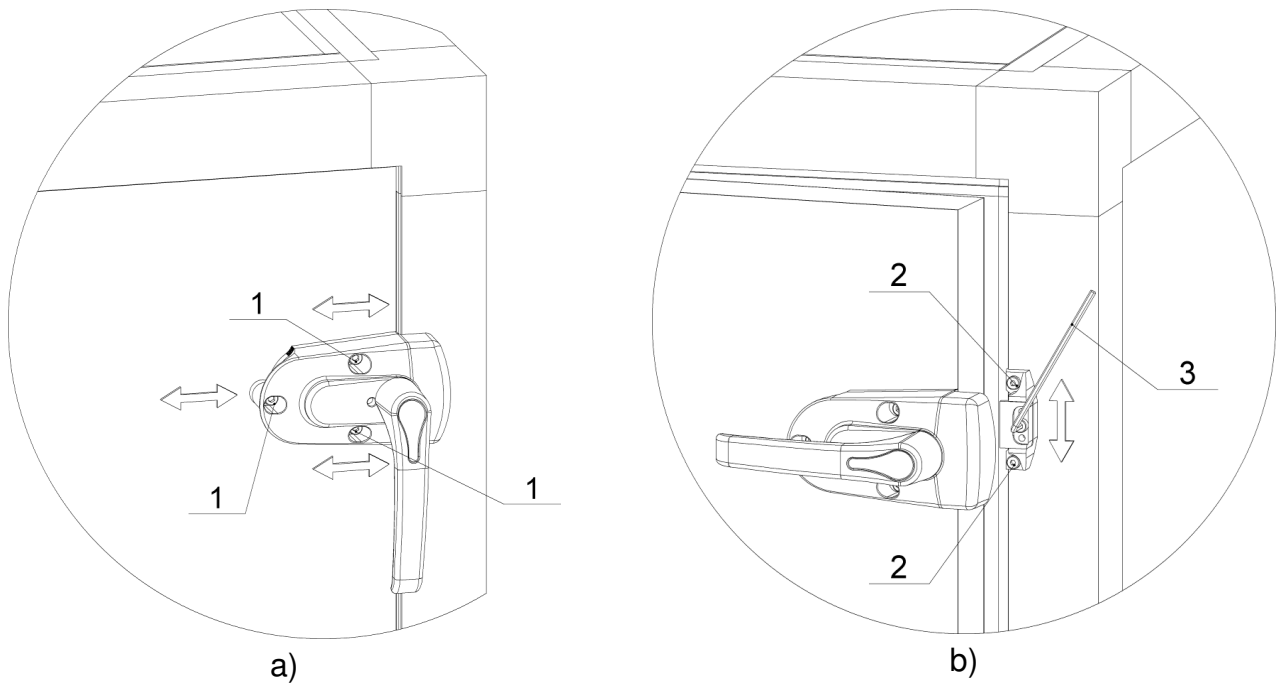

Figure 9.5.2 - AmberAir handle adjustment sequence.

Hinge adjustment (Figure 9.5.3):

1. Remove hinge cover 1 (Figure 9.5.3 a).
2. Loosen the two screws 2 securing the mobile element (Figure 9.5.3 b).
3. Turn the screw 3 for horizontal door alignment.
4. Turn the screw 4 for the adjustment of gasket compression (Figure 9.5.3 c).
5. Tighten the two screws 5 securing the mobile element.
6. Assembly hinge cover 1.
7. Loosen self-tapping screws 5 (Figure 9.5.3 d).
8. Move hinge 7 up or down for vertical door alignment.
9. Tighten self-tapping screws 5.

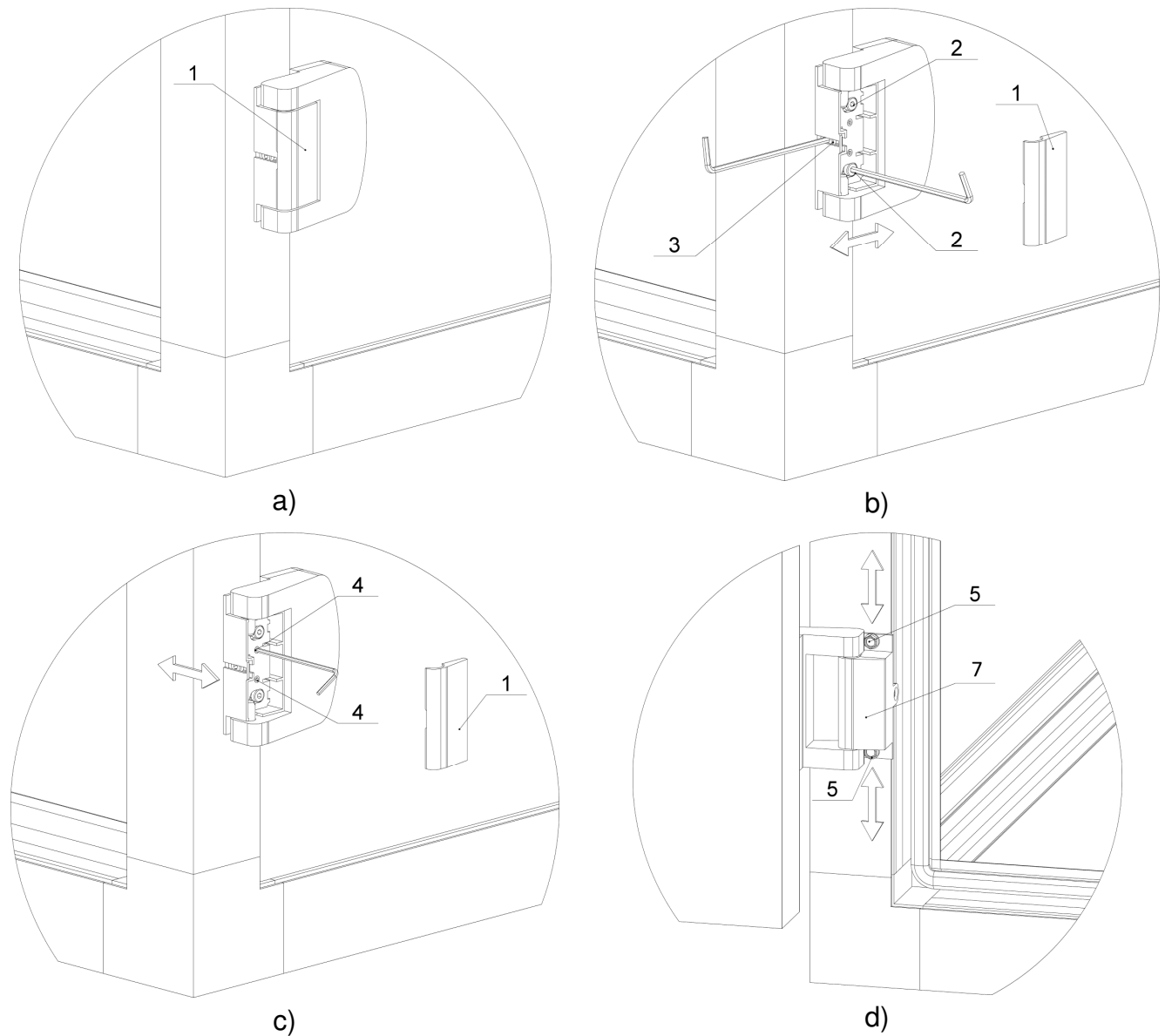

Figure 9.5.3 - AmberAir hinge adjustment sequence.

## 9.6. Shutdown and decommissioning

### Shutdown:

If the system is about to be shut down for a longer period, instructions for the individual sections must be observed. Additionally individual component's manufacturer information must be observed. Risk of freezing during winter time must be taken into account.

### Dismantling:

Only qualified and licensed personnel are allowed to disassemble and dispose the unit after the service life has expired. Please observe safety regulations for every component as well as the component manufacturer's instructions to avoid any damage to persons or property.

When carrying out decommissioning and dismantling work on the unit, disconnect all power supply connections, ensure the power cannot be inadvertently energized and verify that electric

lines have been disconnected. Earth and short-circuit them, and cover or otherwise isolate any neighbouring live parts. Not following safety instructions can lead to death or serious injury.

#### Disposal:

All components (i.e. activated carbon filters) and operating materials (i.e. oils, refrigerants, batteries) must be disposed in line with local regulations by authorized appointed contractor specializing in waste processing. All metal and plastic parts should be separated and sent for recycling.

## 9.7. Fire protection and fire emergency

#### Fire protection:

Possible spreading of fire between AHU and rooms through ducts must be prevented by system installer using appropriate protection devices (e.g. fire and smoke dampers). A possibly required downstream mounted grid (wire mesh width 20 x 20mm) or a suitable downstream air conditioning component made of non-combustible material according to EN 1886:2008 must be installed within the system to prevent any carry-over of flammable parts from filters, droplet eliminators or contact humidifiers into the supply air duct.

Observe national fire regulations requirements.

#### Fighting fire:

In case of fire emergency, comply with national fire regulations requirements. If there is fire, immediately disconnect power supply to the unit and close all dampers in order to stop oxygen supply spread of the fire. Fire-fighting and first aid measures must be directed and fire brigade must be informed immediately. Prioritize protecting people over protecting property.

#### Emission of noxious substances in case of fire:

During fire, noxious substances and gases are released to environment by burning components and materials. Serious health problems or even loss of life might be caused if noxious gases are inhaled. Use heavy duty breathing protection. Serious damage may be caused to health and property by bursting of pressure vessels or pipelines during a fire. Keep away from danger area.

## 10. Warranty

1. All equipment manufactured in our factory is checked in operating conditions and tested before delivery. The equipment is shipped in good working order and condition to the direct client. The unit is warrantied for the period of two years from the invoice date.
2. If equipment is found to have been damaged during transportation, a claim should be made against carrier, as we assume no responsibility for such damage.
3. This warranty does not apply:
  - 3.1. When transportation, storage, installation and maintenance instructions of the unit are violated.
  - 3.2. When the equipment is improperly maintained, mounted - inadequate maintenance.
  - 3.3. When the equipment without our knowledge and permission has been upgraded or unskilled repairs were made.
  - 3.4. When the unit was used not for its original purpose.
4. This warranty does not apply at these malfunction cases:
  - 4.1. Mechanical damage.
  - 4.2. Damage caused by entering outside objects, materials, liquids.
  - 4.3. Damage caused by natural disaster, accident (voltage change in the electricity network, lightning, etc.).
5. The company assumes no liability for its products either directly or indirectly damage, if the damage is caused by failure to comply with installation and mounting regulations, deliberate or careless users or third-party behaviour.

These conditions are readily discernible when the equipment is returned to our factory for inspection.

If the direct client determines that equipment is found to be faulty, or a breakdown occurred, he should inform the manufacturer within five working days and deliver the equipment to manufacturer. Delivery costs should be covered by customer.

## 11. Checklist for operation and maintenance

Periodically check, clean and repair (if necessary) all AHU components. Proper maintenance ensures a long service life of the unit. Document and keep all maintenance works journal in a well-known place.

Detailed maintenance instructions for each component stated in chapter 6. Maintenance intervals stated in the following table.

Table 11.1 Components maintenance intervals

Component	Action if required	Interval
<b>Unit housing</b>		
Check for contamination, damage and corrosion on the air side	clean and repair	12 months
Check empty housings for contamination, damage, and corrosion	clean and repair	12 months
<b>Fan</b>		
Check for contamination, damage, and corrosion	clean and repair	6 months
Fan / motor bearing	check and repair	1 month
Belt tension and alignment (for belt driven fans only)	check and repair	1 month
Flexible connection	clean and repair or replace	1 month
<b>Air filters</b>		
Check for unacceptable contamination and damage (leakages) and odours	change any affected air filters	3 months
Check differential pressure	change filter stage	6 months
Maximum interval until first filter stage is to be changed		12 months
Maximum interval until second filter stage is to be changed		24 months
<b>Heat exchangers (including heat recovery coils)</b>		
Visual inspection of air-to-air plate heat exchangers for contamination, damage, corrosion	clean, repair	6 months
Visual inspection of air-to-air rotary heat exchangers for contamination, damage, corrosion, and tightness	adjust seals, clean, repair	6 months
Heaters: Check for contamination, damage, corrosion, and tightness	clean and repair or replace	6 months



Table 11.1 Components maintenance intervals

Component	Action if required	Interval
Coolers: Check tube bundles, droplet eliminators and drip tray for contamination, corrosion, damage, and tightness	clean and repair or replace	3 months
Check drain and siphon	clean and repair or replace	3 months
<b>Electric heater</b>		
Check for contamination, damage, and corrosion	clean and repair	6 months
<b>Sound attenuators</b>		
Check sound attenuators for contamination, damage, and corrosion	clean or replace	3 months
<b>Damper</b>		
Check for contamination, damage, and corrosion	clean and repair	6 months
<b>Air humidifiers operating with recirculating water</b>		
Check for contamination, damage, microbial growth, and corrosion	clean and repair	1 month during humidification period
Check shutdown controls	readjust	12 months
Check circulation pump for contamination and deposits in the intake line, check condition and functioning of filters	clean pump circuit	3 months
Completely empty and dry humidifier unit		during standstills (> 48 h)
Check drain	clean and repair	3 months
<b>Air humidifiers operating without recirculating water</b>		
Check for contamination, damage, microbial growth, and corrosion	clean and repair	3 months
Check for condensate precipitation in the humidifier chamber	clean and repair steam humidifier	1 month
Check vapour distribution system for deposits	clean	6 months
Check spray nozzles for deposits	clean or replace nozzles	1 month
Check drain	clean and repair	3 months
<b>Outdoor grilles and hood</b>		
Check for contamination, damage, and corrosion	clean and repair	6 months





