

AIR CONDITIONER

Cassette type

SERVICE MANUAL



INDOOR

AUXG09KVLA
AUXG12KVLA
AUXG14KVLA
AUXG18KVLA
AUXG22KVLA

OUTDOOR



AOYG09KATA
AOYG12KATA



AOYG14KATA
AOYG18KATA



AOYG22KATA

FUJITSU GENERAL LIMITED

Notices:

- Product specifications and design are subject to change without notice for future improvement.
- For further details, please check with our authorized dealer.

Trademarks

The following term and logo are trademarks of Fujitsu General Limited in the United States, other countries or both:

FGLair™



Android and Google Play are trademarks of Google Inc.

App Store is a service mark of Apple Inc., registered in the U.S. and other countries.

IOS is a trademark or registered trademark of Cisco in the U.S. and other countries and is used under license.

CONTENTS

1. GENERAL INFORMATION

2. TECHNICAL DATA AND PARTS LIST

1. GENERAL INFORMATION

CONTENTS

1. GENERAL INFORMATION

1. Specifications	01-1
1-1. Indoor unit	01-1
1-2. Outdoor unit.....	01-5
2. Dimensions	01-7
2-1. Indoor unit	01-7
2-2. Outdoor unit.....	01-9

1. Specifications

1-1. Indoor unit

Type				Cassette				
				Inverter heat pump				
Model name				AUXG09KVLA	AUXG12KVLA	AUXG14KVLA		
Power supply				230 V ~ 50 Hz				
Power supply intake				Outdoor unit				
Available voltage range				198—264 V				
Capacity	Cooling	Rated	kW	2.50	3.50	4.30		
			Btu/h	8,500	11,900	14,700		
		Min.—Max.	kW	0.90—2.70	0.90—3.70	0.90—4.50		
	Heating	Rated	Btu/h	3,100—9,200	3,100—12,600	3,100—15,300		
			kW	3.20	4.10	5.00		
		Min.—Max.	Btu/h	10,900	13,400	17,000		
Input power	Cooling	Rated	kW	0.68	1.09	1.37		
			Max.	1.59	1.78	2.12		
		Heating	Rated	0.88	1.17	1.42		
	Heating	Rated	kW	1.59	1.78	2.12		
			Max.	3.4	5.2	6.4		
		Heating	Rated	4.4	5.8	6.6		
Current	Cooling	Rated	A	3.4	5.2	6.4		
	Heating		A	4.4	5.8	6.6		
Power factor	Cooling	Rated	%	87.0	91.1	93.1		
	Heating		%	87.0	87.7	93.5		
EER	Cooling	Rated	kW/kW	3.68	3.21	3.14		
COP	Heating		kW/kW	3.64	3.50	3.52		
Moisture removal			L/h (pints/h)	0.6 (1.1)	1.2 (2.1)	1.5 (2.6)		
Maximum operating current *1			Cooling	A	6.9	9.2		
			Heating	A	6.9	9.2		
Fan	Airflow rate	Cooling	HIGH	m ³ /h	540	680		
			MED	490	580			
			LOW	440	490			
			QUIET	390	410			
		Heating	HIGH	540	800			
			MED	490	680			
			LOW	440	580			
			QUIET	390	450			
	Type × Q'ty			Turbo × 1				
	Motor output			W	54			
Sound pressure level *2			Cooling	HIGH	33	38		
				MED	31	34		
				LOW	29	30		
				QUIET	27	27		
			Heating	HIGH	34	43		
				MED	32	38		
				LOW	29	34		
				QUIET	27	30		
Heat exchanger type			Dimensions (H × W × D)	mm	Main 1: 210 × 1,310 × 13.3			
					Main 2: 210 × 1,250 × 13.3			
			Fin pitch		Main 1: 1.2			
			Main 2: 1.2					
			Rows × Stages		Main 1: 1 × 10			
			Main 2: 1 × 10					
Pipe type	Copper tube							
Fin type	Aluminum							
Dimensions (H × W × D)			Net	mm	245 × 570 × 570			
			Gross	mm	265 × 730 × 625			
Weight			Net	kg	15			
			Gross	kg	19			
Connection pipe			Size	Liquid	Ø 6.35 (Ø 1/4)			
					Gas	Ø 9.52 (Ø 3/8)		
Method			Flare					
Operation range			Cooling	°C	18 to 32			
				%RH	80 or less			
Heating			°C	16 to 30				
Cassette grille (Grid type: Option)			Material			Polystyrene		
			Color			White		
						Approximate color of Munsell 9PB 9.1/0.2		
			Dimensions (H × W × D)	Net	mm	49 × 620 × 620		
				Gross	mm	120 × 765 × 755		
Weight	Net	kg	2.3					
	Gross	kg	4.5					
Remote control (Option)			Wired remote controller, Wireless remote controller, Mobile app*3 (FGLair™)					
Drain hose			Material			PVC		
			Size			mm		
			VP25 [Ø 25 (I.D.), Ø 32 (O.D.)]					

NOTES:

- Specifications are based on the following conditions:
 - Cooling: Indoor temperature of 27 °CDB/19 °CWB, and outdoor temperature of 35 °CDB/24 °CWB.
 - Heating: Indoor temperature of 20 °CDB/15 °CWB, and outdoor temperature of 7 °CDB/6 °CWB.
 - Pipe length: 5.0 m, Height difference: 0 m. (Between outdoor unit and indoor unit.)
- Protective function might work when using it outside the operation range.
- *1: Maximum operating current is the total current of the indoor unit and the outdoor unit.
- *2: Sound pressure level:
 - Measured values in manufacturer's anechoic chamber.
 - Because of the surrounding sound environment, the sound levels measured in actual installation conditions might be higher than the specified values here.
- *3: Available on Google Play™ store or on App Store®. Optional WLAN adapter is also required. For details, refer to the setting manual.

Specifications for ErP Lot10						
Model name		AUXG09KVLA		AUXG12KVLA	AUXG14KVLA	
Energy efficiency class	Cooling	A ⁺⁺				
	Heating (Average)	A ⁺				
P _{design}	Cooling	kW	2.5 (35°C)	3.5 (35°C)	4.3 (35°C)	
	Heating (Average)		2.3 (-10°C)	2.8 (-10°C)	3.2 (-10°C)	
SEER	Cooling	kWh/kWh	6.20	6.10	6.10	
SCOP	Heating (Average)		4.00	4.00	4.00	
Annual energy consumption	QCE	kWh/a	141	201	247	
	QHE (Average)		804	979	1,120	
Sound power level	Cooling	HIGH	dB (A)	46	49	50
	Heating			47	49	55

Type				Cassette		
				Inverter heat pump		
Model name				AUXG18KVLA	AUXG22KVLA	
Power supply				230 V ~ 50 Hz		
Power supply intake				Outdoor unit		
Available voltage range				198—264 V		
Capacity	Cooling	Rated	kW	5.20	6.00	
			Btu/h	17,700	20,500	
		Min.—Max.	kW	0.90—5.40	0.90—6.30	
			Btu/h	3,100—18,400	3,100—21,400	
	Heating	Rated	kW	6.00	7.00	
			Btu/h	20,500	23,900	
Min.—Max.		kW	0.90—6.30	0.90—7.40		
		Btu/h	3,100—21,400	3,100—25,200		
Input power	Cooling	Rated	kW	1.69	1.95	
		Max.		2.33	2.67	
	Heating	Rated		1.72	2.00	
		Max.		2.33	2.67	
Current	Cooling	Rated	A	7.8	8.6	
	Heating			7.9	8.8	
Power factor	Cooling			94.2	98.6	
	Heating			94.7	98.8	
EER	Cooling			3.08	3.08	
COP	Heating			3.49	3.50	
Moisture removal			L/h (pints/h)	2.2 (3.9)	2.6 (4.6)	
Maximum operating current *1		Cooling	A	10.1	11.6	
		Heating		10.1	11.6	
Fan	Airflow rate	Cooling	HIGH	m ³ /h	680	830
			MED		580	740
			LOW		490	600
			QUIET		410	450
		Heating	HIGH		800	860
			MED		680	760
			LOW		580	700
			QUIET		450	530
	Type × Q'ty		Turbo × 1			
	Motor output		W			
		54				
Sound pressure level *2	Cooling	HIGH	dB (A)	38	44	
		MED		34	42	
		LOW		30	36	
		QUIET		26	30	
	Heating	HIGH		43	45	
		MED		38	43	
		LOW		34	40	
		QUIET		30	33	
Heat exchanger type	Dimensions (H × W × D)		mm	Main 1: 210 × 1,310 × 13.3 Main 2: 210 × 1,250 × 13.3		
	Fin pitch			Main 1: 1.2 Main 2: 1.2		
	Rows × Stages			Main 1: 1 × 10 Main 2: 1 × 10		
	Pipe type			Copper tube		
	Fin type			Aluminum		
Dimensions (H × W × D)	Net		mm	245 × 570 × 570		
	Gross			265 × 730 × 625		
Weight	Net		kg	15	16	
	Gross			19	20	
Connection pipe	Size	Liquid	mm (in)	Ø 6.35 (Ø 1/4)		
		Gas		Ø 12.70 (Ø 1/2)		
	Method			Flare		
Operation range	Cooling	°C	18 to 32			
		%RH	80 or less			
	Heating	°C	16 to 30			
Cassette grille (Grid type: Option)	Material		Polystyrene			
	Color		White Approximate color of Munsell 9PB 9.1/0.2			
	Dimensions (H × W × D)	Net	mm	49 × 620 × 620		
		Gross		120 × 765 × 755		
	Weight	Net	kg	2.3		
Gross		4.5				
Remote control (Option)				Wired remote controller, Wireless remote controller, Mobile app*3 (FGLair™)		
Drain hose	Material		PVC			
	Size		mm			
		VP25 [Ø 25(I.D.), Ø 32(O.D.)]				
NOTES:						
<ul style="list-style-type: none"> Specifications are based on the following conditions: <ul style="list-style-type: none"> Cooling: Indoor temperature of 27 °CDB/19 °CWB, and outdoor temperature of 35 °CDB/24 °CWB. Heating: Indoor temperature of 20 °CDB/15 °CWB, and outdoor temperature of 7 °CDB/6 °CWB. Pipe length: 5.0 m, Height difference: 0 m. (Between outdoor unit and indoor unit.) Protective function might work when using it outside the operation range. *1: Maximum operating current is the total current of the indoor unit and the outdoor unit. *2: Sound pressure level: <ul style="list-style-type: none"> Measured values in manufacturer's anechoic chamber. Because of the surrounding sound environment, the sound levels measured in actual installation conditions might be higher than the specified values here. *3: Available on Google Play™ store or on App Store®. Optional WLAN adapter is also required. For details, refer to the setting manual. 						

Specifications for ErP Lot10				
Model name		AUXG18KVLA		AUXG22KVLA
Energy efficiency class	Cooling	A ⁺⁺		
	Heating (Average)	A		
Pdesign	Cooling	kW	5.2 (35°C)	6.0 (35°C)
	Heating (Average)		3.8 (-10°C)	4.4 (-10°C)
SEER	Cooling	kWh/kWh	6.10	6.10
SCOP	Heating (Average)		3.90	3.90
Annual energy consumption	QCE	kWh/a	298	344
	QHE (Average)		1,362	1,578
Sound power level	Cooling	HIGH	dB (A)	50
	Heating			55

1-2. Outdoor unit

Type			Inverter heat pump		
Model name			AOYG09KATA	AOYG12KATA	AOYG14KATA
Power supply			230 V ~ 50 Hz		
Available voltage range			198—264 V		
Starting current			A	4.4	5.8
Fan	Airflow rate	Cooling	m ³ /h	1,610	1,630
		Heating		1,550	1,410
	Type × Q'ty	Propeller fan × 1			
Motor output			W	23	
Sound pressure level *1	Cooling	Heating	dB (A)	47	49
		Heating		48	50
Sound power level	Cooling	Heating	dB (A)	60	62
		Heating		60	62
Heat exchanger type	Dimensions (H × W × D)	mm	504 × 650 × 18.19	Main 1: 504 × 630 × 18.19 Main 2: 504 × 630 × 18.19	Main 1: 504 × 881 × 18.19 Main 2: 504 × 851 × 18.19
	Fin pitch		1.3	Main 1: 1.3 Main 2: 1.3	
	Rows × Stages	1 × 24	Main 1: 1 × 24 Main 2: 1 × 24		
	Pipe type	Copper			
	Fin type	Type (Material)	Aluminum		
	Surface treatment	PC fin			
Compressor	Type × Q'ty	DC rotary × 1			
	Motor output	W	550	900	
Refrigerant	Type (Global warming potential)	R32 (675)			
	Charge	g	600	700	850
Refrigerant oil	Type	RB74AF			
	Amount	cm ³	240		340
Enclosure	Material	Steel sheet			
	Color	Beige Approximate color of Munsell 10YR 7.5/1.0			
Dimensions (H × W × D)	Net	mm	541 × 663 × 290	542 × 799 × 290	
	Gross		602 × 804 × 375	602 × 940 × 375	
Weight	Net	kg	23	25	32
	Gross		27	29	36
Connection pipe	Size	Liquid	mm (in)	Ø 6.35 (Ø 1/4)	
		Gas		Ø 9.52 (Ø 3/8)	
	Method	Flare			
	Pre-charge length	m	15		
	Max. length		15	20	
Max. height difference	15				
Operation range	Cooling	°C	-10 to 46		
	Heating		-15 to 24		
Drain hose	Material	PP			
	Size	mm	Ø 13.0 (I. D.), Ø 16.0 to Ø 16.8 (O. D.)		

NOTES:

- Specifications are based on the following conditions:
 - Cooling: Indoor temperature of 27 °CDB/19 °CWB, and outdoor temperature of 35 °CDB/24 °CWB.
 - Heating: Indoor temperature of 20 °CDB/15 °CWB, and outdoor temperature of 7 °CDB/6 °CWB.
 - Pipe length: 5.0 m, Height difference: 0 m.
- Protective function might work when using it outside the operation range.
- *1: Sound pressure level
 - Measured values in manufacturer's anechoic chamber.
 - Because of the surrounding sound environment, the sound levels measured in actual installation conditions might be higher than the specified values here.

Type				Inverter heat pump			
Model name				AOYG18KATA		AOYG22KATA	
Power supply				230 V ~ 50 Hz			
Available voltage range				198—264 V			
Starting current				A		7.9	
Fan	Airflow rate	Cooling	m ³ /h	1,710		2,240	
		Heating		1,840		2,240	
	Type × Q'ty	Propeller fan × 1					
Motor output				W		23	
Sound pressure level *1	Cooling	Heating	dB (A)	51		52	
				52		53	
Sound power level	Cooling	Heating	dB (A)	63		64	
				64		65	
Heat exchanger type	Dimensions (H × W × D)		mm	Main 1: 504 × 881 × 18.19		Main 1: 588 × 881 × 18.19	
	Main 2: 504 × 851 × 18.19			Main 2: 588 × 851 × 18.19			
	Fin pitch		Main 1: 1.3 Main 2: 1.3				
	Rows × Stages		Main 1: 1 × 24 Main 2: 1 × 24		Main 1: 1 × 28 Main 2: 1 × 28		
	Pipe type		Copper				
Compressor	Type × Q'ty	W		DC rotary × 1		DC twin rotary × 1	
	Motor output	900					
Refrigerant	Type (Global warming potential)		R32 (675)				
	Charge	g		900		1,100	
Refrigerant oil	Type	cm ³		RB68A		FW68S	
	Amount	340		340		350	
Enclosure	Material		Steel sheet				
	Color		Beige Approximate color of Munsell 10YR 7.5/1.0				
Dimensions (H × W × D)	Net	mm		542 × 799 × 290		632 × 799 × 290	
	Gross	602 × 940 × 375		692 × 940 × 375			
Weight	Net	kg		33		36	
	Gross	36		40			
Connection pipe	Size	Liquid	mm (in)	Ø 6.35 (Ø 1/4)			
		Gas		Ø 12.70 (Ø 1/2)			
	Method		Flare				
	Pre-charge length		15				
	Max. length		m		20		25
Max. height difference		15		20			
Operation range	Cooling	Heating	°C	-10 to 46			
				-15 to 24			
Drain hose	Material		PP				
	Size		mm Ø 13.0 (I. D.), Ø 16.0 to Ø 16.8 (O. D.)				
NOTES:							
<ul style="list-style-type: none"> • Specifications are based on the following conditions: <ul style="list-style-type: none"> – Cooling: Indoor temperature of 27 °CDB/19 °CWB, and outdoor temperature of 35 °CDB/24 °CWB. – Heating: Indoor temperature of 20 °CDB/15 °CWB, and outdoor temperature of 7 °CDB/6 °CWB. – Pipe length: 5.0 m, Height difference: 0 m (Between outdoor unit and indoor unit.). • Protective function might work when using it outside the operation range. • *1: Sound pressure level <ul style="list-style-type: none"> – Measured values in manufacturer's anechoic chamber. – Because of the surrounding sound environment, the sound levels measured in actual installation conditions might be higher than the specified values here. 							

2. Dimensions

2-1. Indoor unit

■ Models: AUXG09KVLA, AUXG12KVLA, AUXG14KVLA, AUXG18KVLA, and AUXG22KVLA

Unit: mm

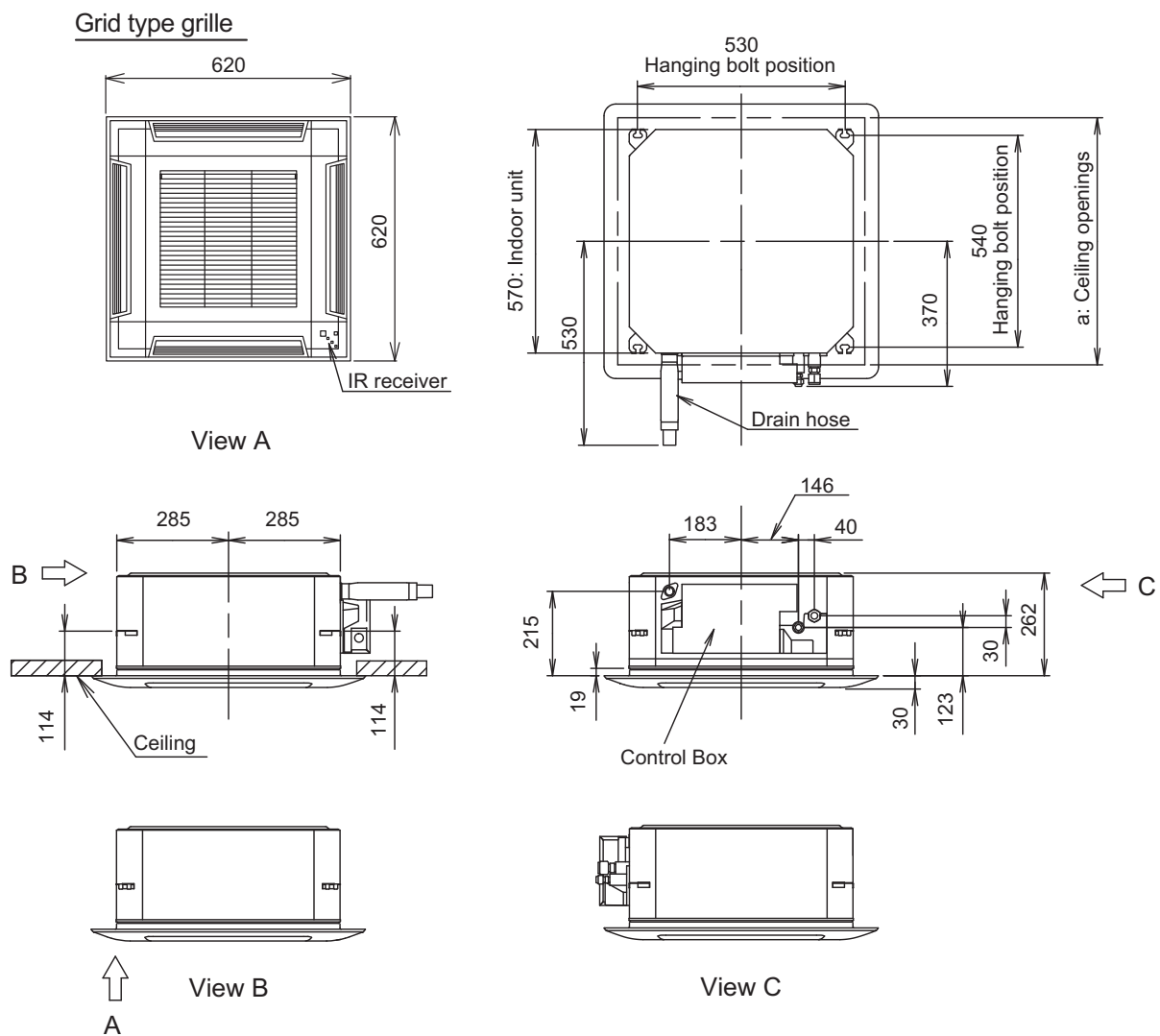

a: Ceiling openings		
Cassette grille (Option [Grid type])	mm	580 to 610

■ Installation space requirement

Unit: mm

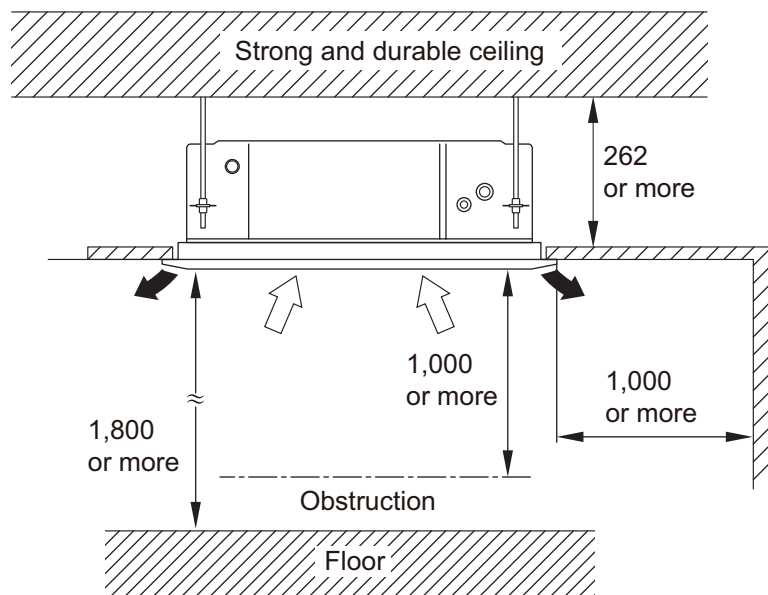

Maximum height from floor to ceiling (Unit: mm)	
Standard	2,700
High ceiling	3,000

3-way direction setting:

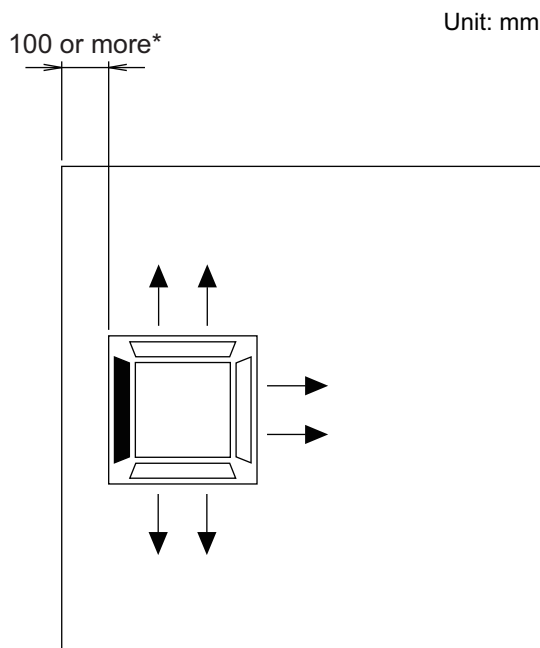

NOTES:

- To set "3-direction", optional Air outlet shutter plate (UTR-YDZB) must be installed, and the "outlet-direction" need to be switched to "3-way" by remote controller.
*When installing the indoor unit, be careful about the maintenance space.
- The ceiling height cannot be set in the 3-way outlet mode. Therefore, ceiling height setting change by function setting 20 is prohibited. For details, refer to "Contents of function setting" on page 1.

2-2. Outdoor unit

■ Models: AOYG09KATA and AOYG12KATA

Unit: mm

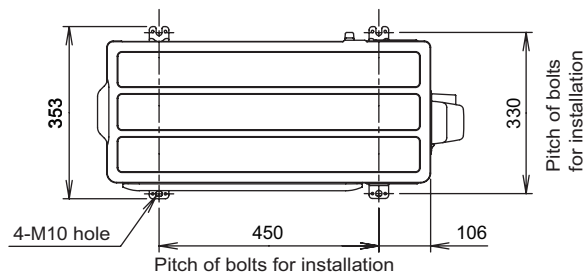

Top view

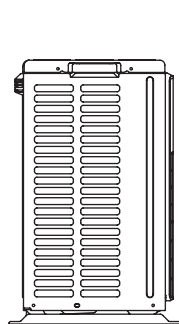

Side view

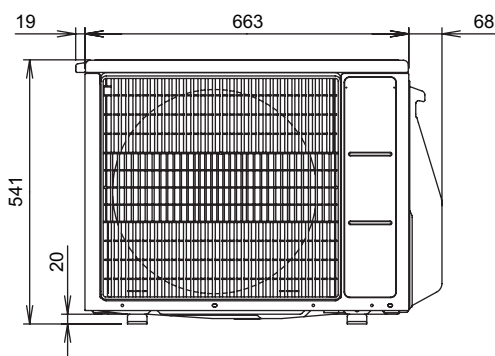

Front view

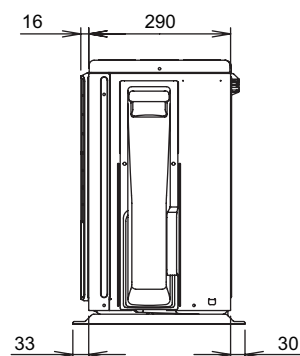

Side view

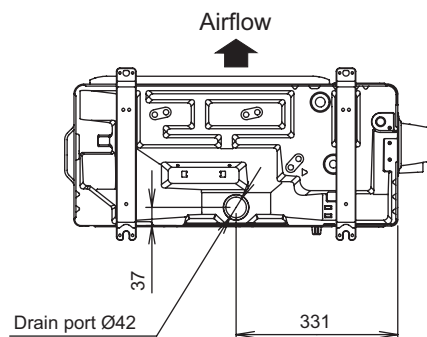

Bottom view

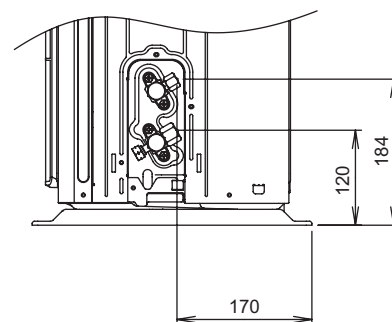

Side view (Valve part)

■ Models: AOYG14KATA and AOYG18KATA

Unit: mm

GENERAL INFORMATION

GENERAL INFORMATION

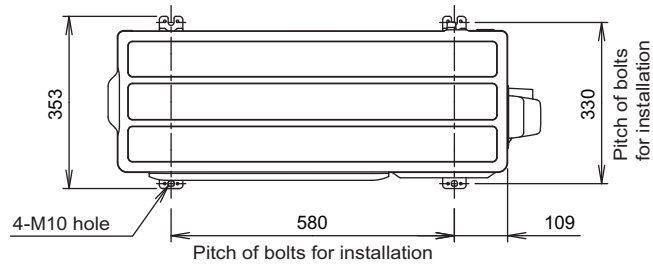

Top view

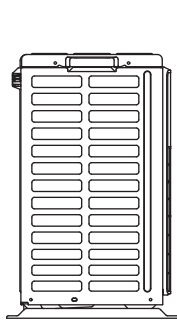

Side view

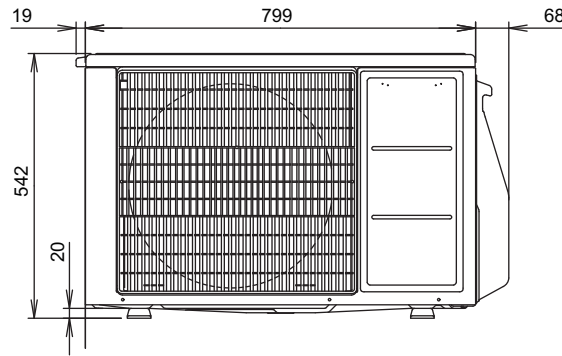

Front view

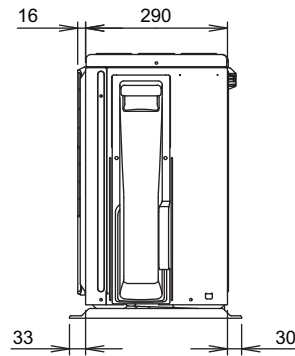

Side view

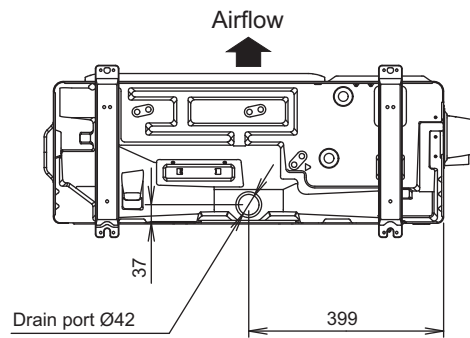

Bottom view

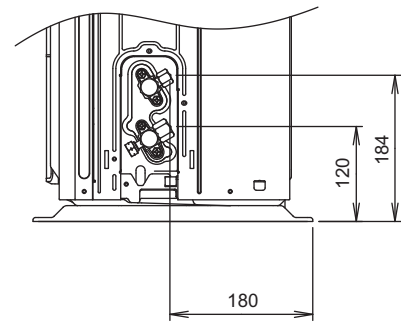

Side view (Valve part)

■ Model: AOYG22KATA

Unit: mm

GENERAL INFORMATION

GENERAL INFORMATION

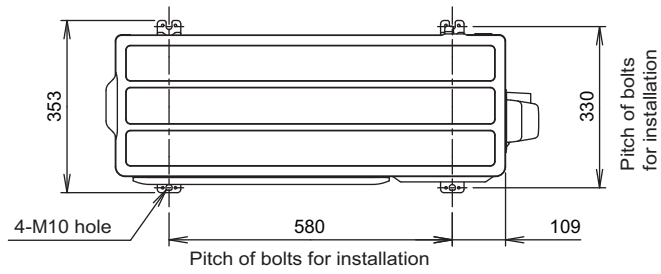

Top view

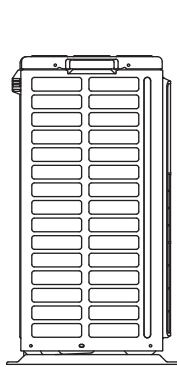

Side view

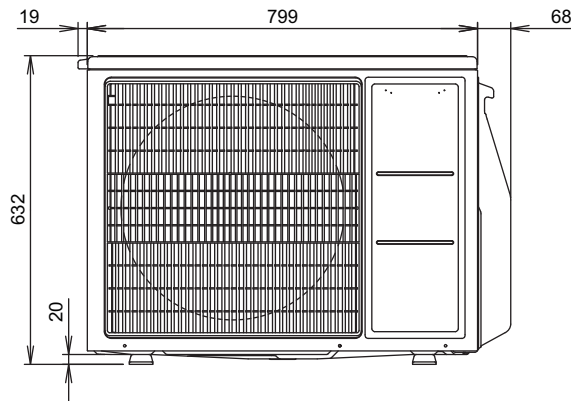

Front view

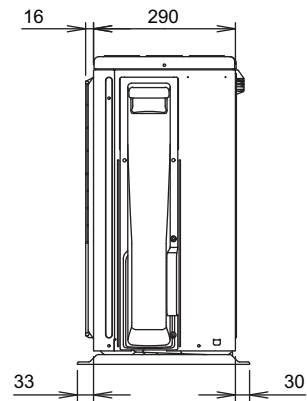

Side view

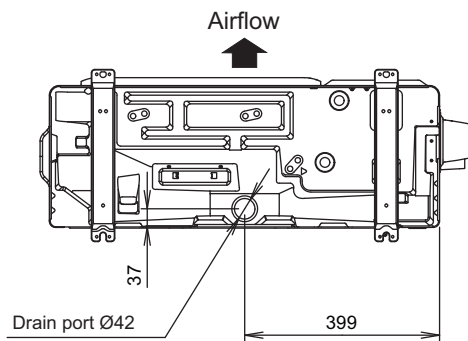

Bottom view

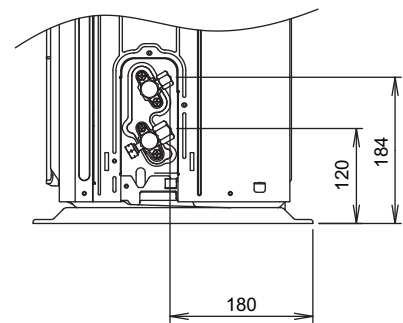

Side view (Valve part)

2. TECHNICAL DATA AND PARTS LIST

CONTENTS

2. TECHNICAL DATA AND PARTS LIST

1. Precautions	02-1
2. Indoor unit parts list	02-2
2-1. Models: AUXG09KVLA, AUXG12KVLA, AUXG14KVLA, AUXG18KVLA, and AUXG22KVLA.....	02-2
3. Outdoor unit parts list	02-7
3-1. Models: AOYG09KATA and AOYG12KATA.....	02-7
3-2. Models: AOYG14KATA and AOYG18KATA.....	02-11
3-3. Model: AOYG22KATA.....	02-15
4. Accessories	02-19
4-1. Indoor unit	02-19
4-2. Outdoor unit.....	02-19
5. Optional parts	02-20
5-1. Indoor unit	02-20
6. Refrigerant system diagrams	02-23
6-1. Models: AOYG09KATA and AOYG12KATA.....	02-23
6-2. Models: AOYG14KATA and AOYG18KATA.....	02-24
6-3. Model: AOYG22KATA.....	02-25
7. Wiring diagrams	02-26
7-1. Indoor unit	02-26
7-2. Outdoor unit.....	02-27
8. PC board diagrams	02-29
8-1.	02-29
8-2. Models: AOYG09KATA, AOYG12KATA, AOYG14KATA, and AOYG18KATA	02-30
8-3. Model: AOYG22KATA.....	02-31

1. Precautions

When you start servicing, pay attention to the following points. For detailed precautions, refer to the installation manual of the products.

⚠ CAUTION

- Service personnel
 - Any person who is involved with working on or breaking into a refrigerant circuit should hold a current valid certificate from an industry-accredited assessment authority, which authorizes their competence to handle refrigerants safely in accordance with an industry recognized assessment specification.
 - Servicing shall only be performed as recommended by the equipment manufacturer. Maintenance and repair requiring the assistance of other skilled personnel shall be carried out under the supervision of the person competent in the use of flammable refrigerants.
 - Servicing shall be performed only as recommended by the manufacturer.
 - Work
 - Prior to beginning work on systems containing flammable refrigerants, safety checks are necessary to ensure that the risk of ignition is minimized. When repairing the refrigerant system, refer to the precautions written in the installation manual of the products before you start servicing.
 - Work shall be undertaken under a controlled procedure so as to minimize the risk of a flammable gas or vapor being present while the work is being performed.
 - All maintenance staff and others working in the local area shall be instructed on the nature of work being carried out.
 - Work in confined spaces shall be avoided.
 - The area around the workspace shall be sectioned off.
 - Ensure that the conditions within the area have been made safe by control of flammable material.
 - Checking for presence of refrigerant
 - The area shall be checked with an appropriate refrigerant detector prior to and during work, to ensure the technician is aware of potentially flammable atmospheres.
 - Ensure that the leak detection equipment being used is suitable for use with flammable refrigerants, i.e. non-sparking, adequately sealed or intrinsically safe.
-
- Service parts information and design are subject to change without notice for product improvement.
 - For the latest information of the service parts, refer to our Service Portal.
<https://fujitsu-general.force.com/portal/>
 - Precise figure of the service parts listed in this manual may differ from the actual service parts.

2. Indoor unit parts list

2-1. Models: AUXG09KVLA, AUXG12KVLA, AUXG14KVLA, AUXG18KVLA, and AUXG22KVLA

TECHNICAL DATA
AND PARTS LIST

TECHNICAL DATA
AND PARTS LIST

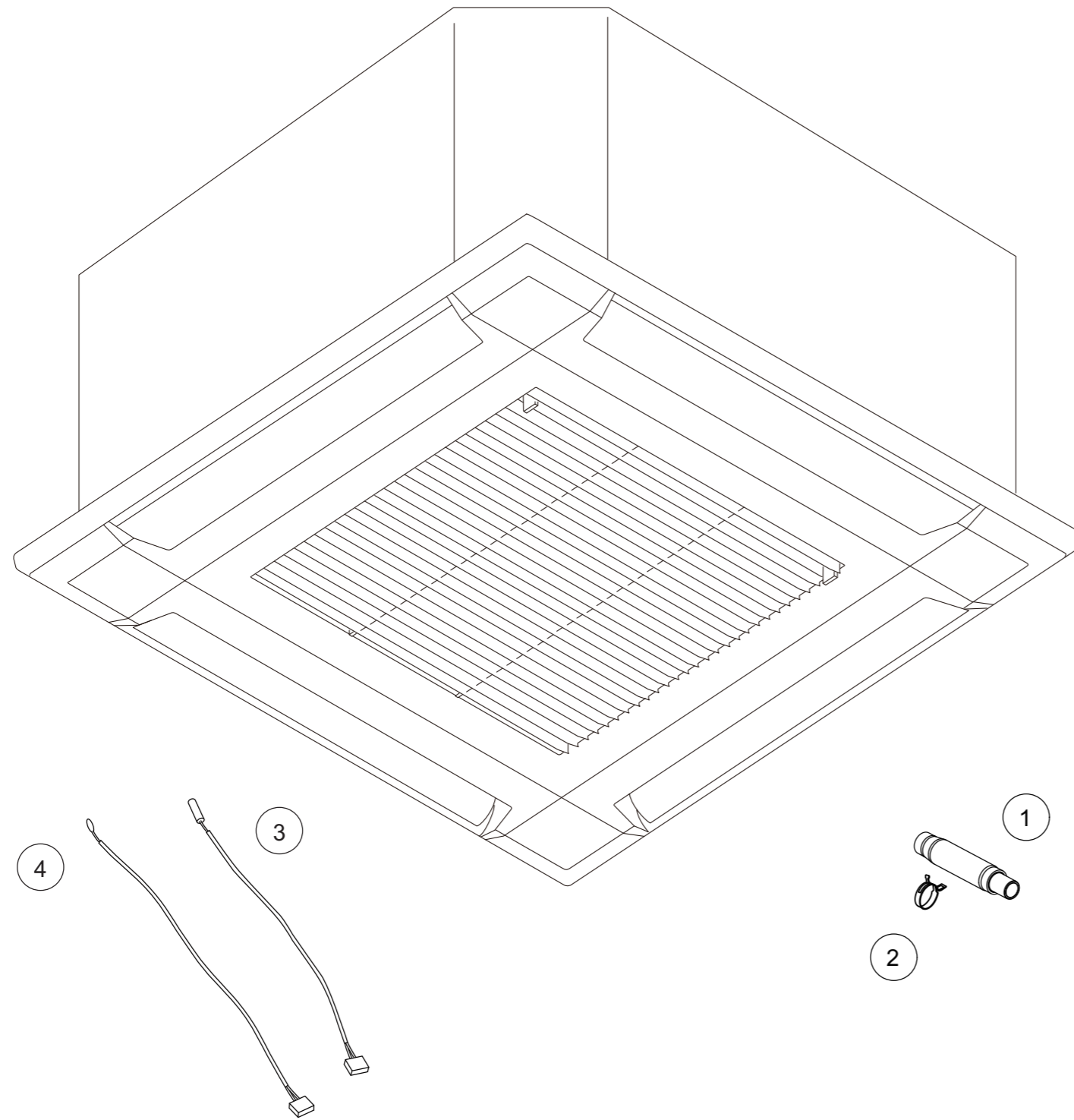

Ref.	Description	Part number
1	Drain hose	9379665001
2	Hose band	9379757010
3	Pipe Thermistor	9900942038
4	Room Thermistor	9900826000

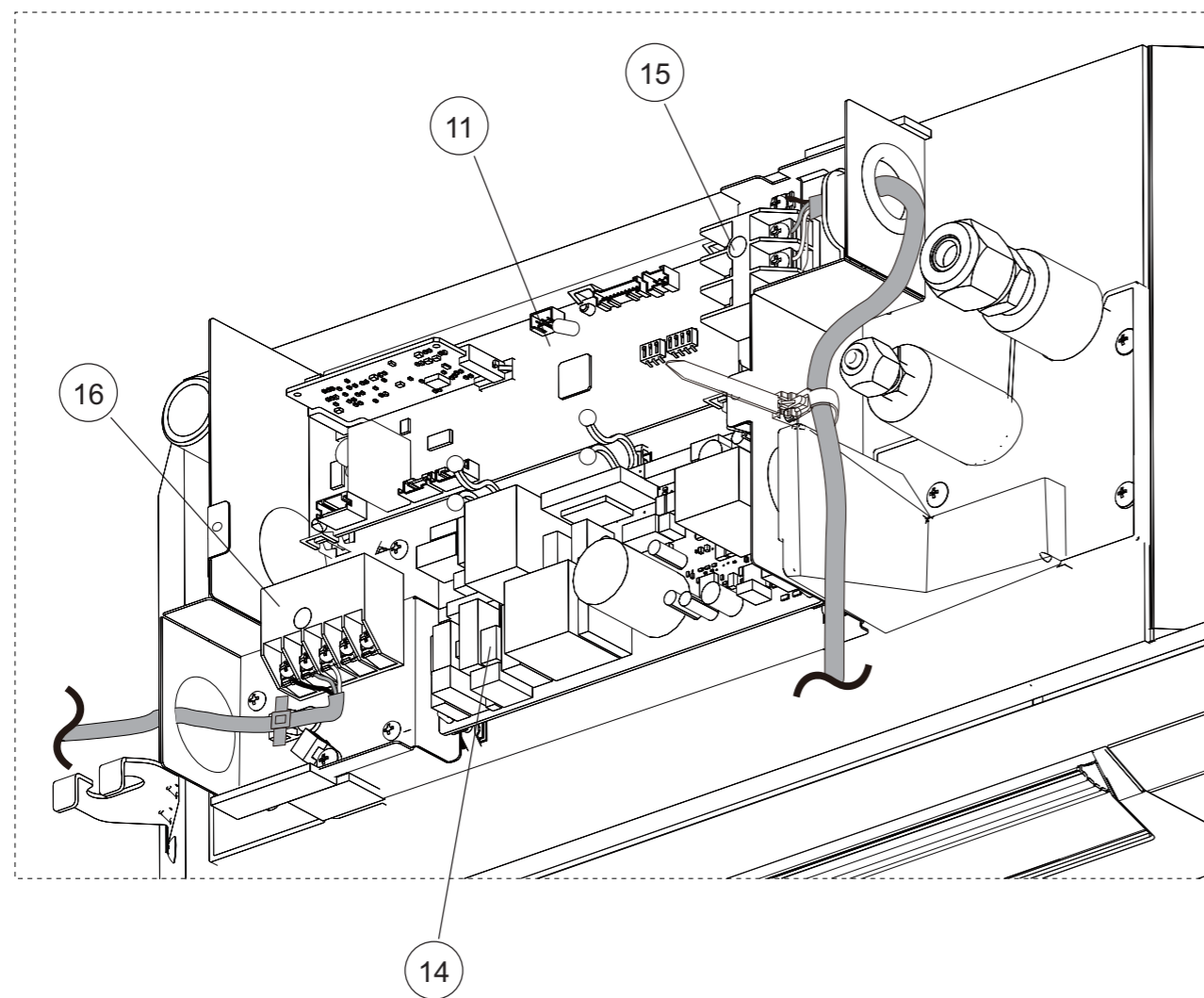
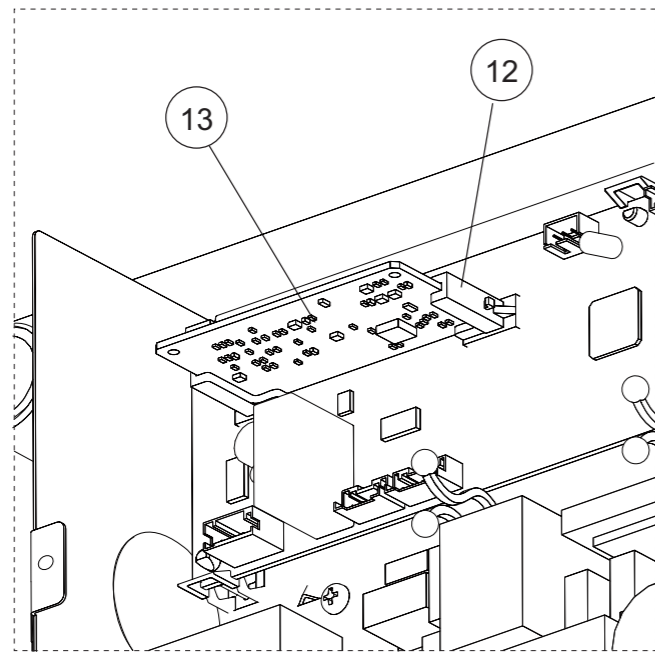

Ref.	Description	Part number
11	Main PCB (07)	9710995965
11	Main PCB (09)	9710995743
11	Main PCB (12)	9710995750
11	Main PCB (14)	9710995705
11	Main PCB (18)	9710995767
11	Main PCB (22)	9710995613
11	Main PCB (24)	9710995866
12	Holder	0600063023
13	Communication PCB	9710019005
14	Power supply PCB	9710661006
15	Terminal	9900568009
16	Terminal	9900896003

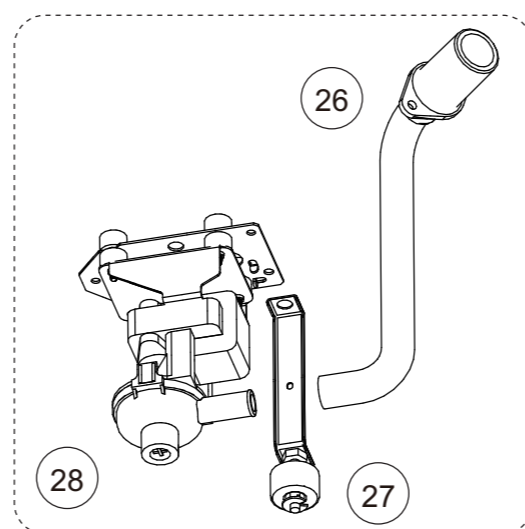
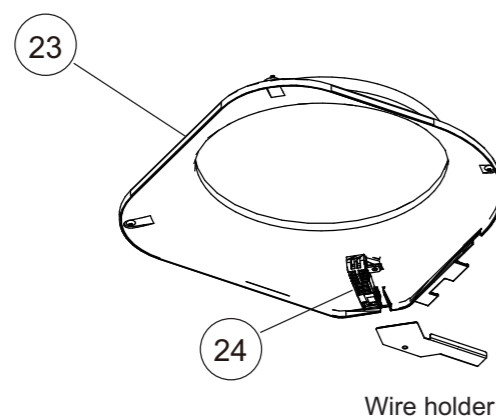
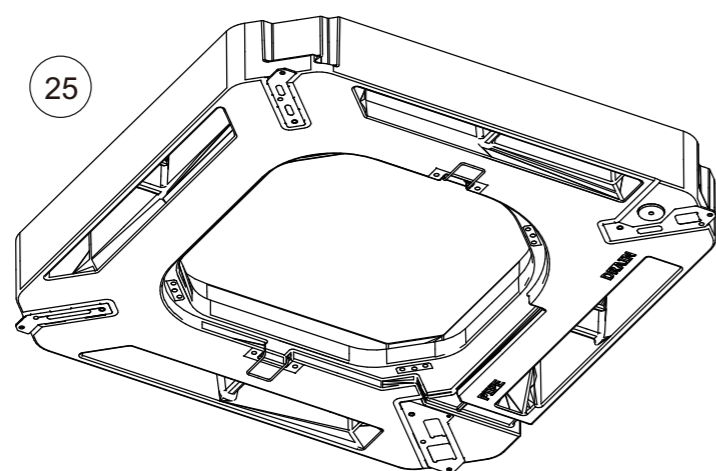
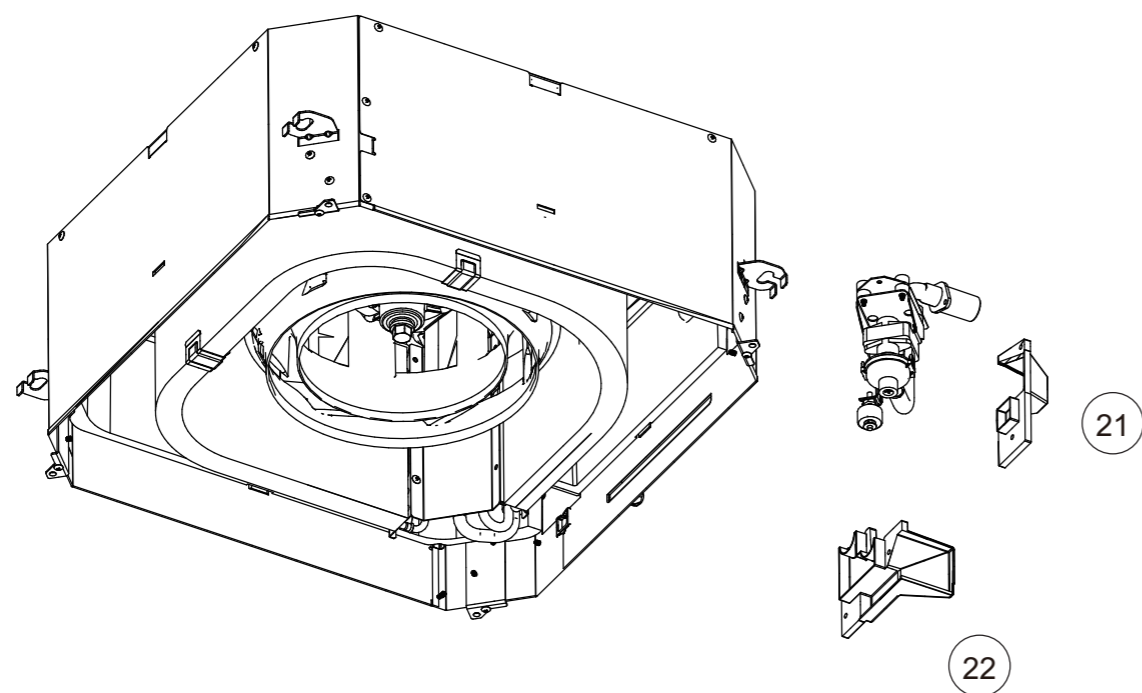

Ref.	Description	Part number
21	Wire cover	9375516017
22	Pipe cover	9375515010
23	Bellmouth	9375503017
24	Thermistor holder	9375477011
25	Drain pan sub assy (18)	9377765024
25	Drain pan sub assy (22, 24)	9377765017
26	Drain port sub assy	9375718015
27	Float Switch sub assy	9375721046
28	Drain pump sub assy	9375717025

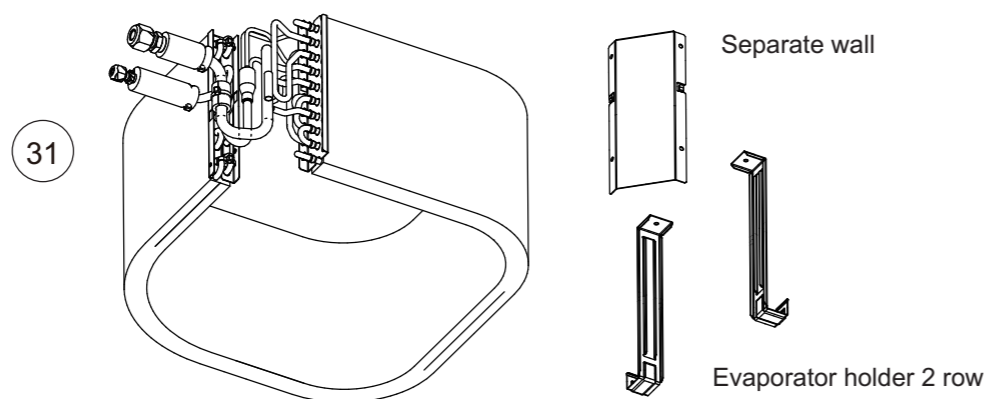
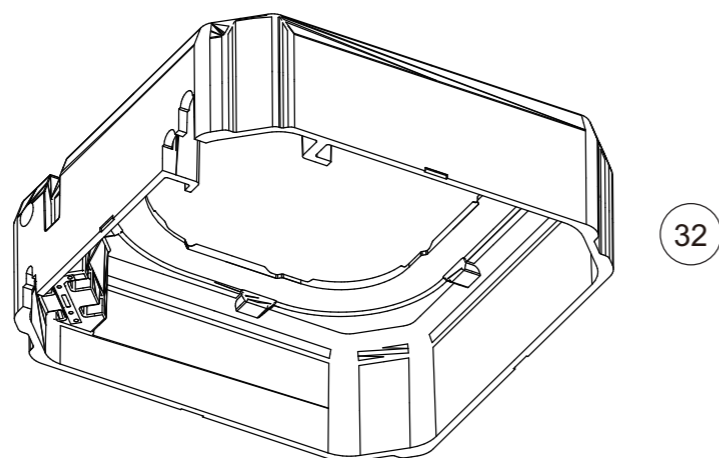
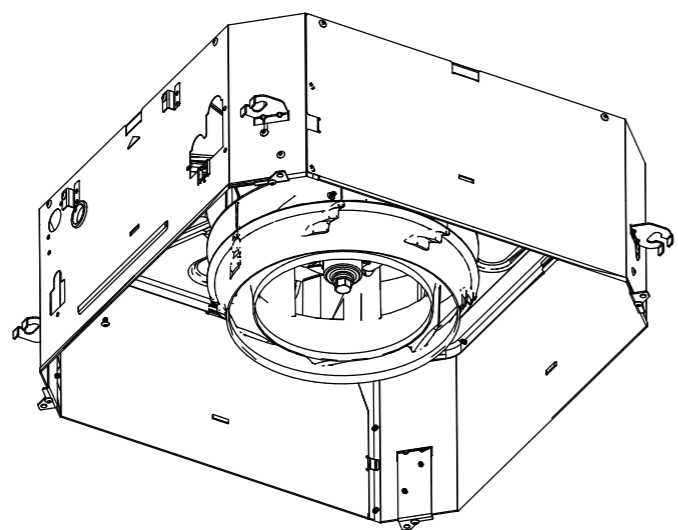

Ref.	Description	Part number
31	Evaporator total assy (07)	9377914156
31	Evaporator total assy (09, 12)	9377914101
31	Evaporator total assy (14)	9377914118
31	Evaporator total assy (18)	9377914125
31	Evaporator total assy (22, 24)	9377914149
32	Insulation box sub assy (07-18)	9377764065
32	Insulation box sub assy (22, 24)	9377764058

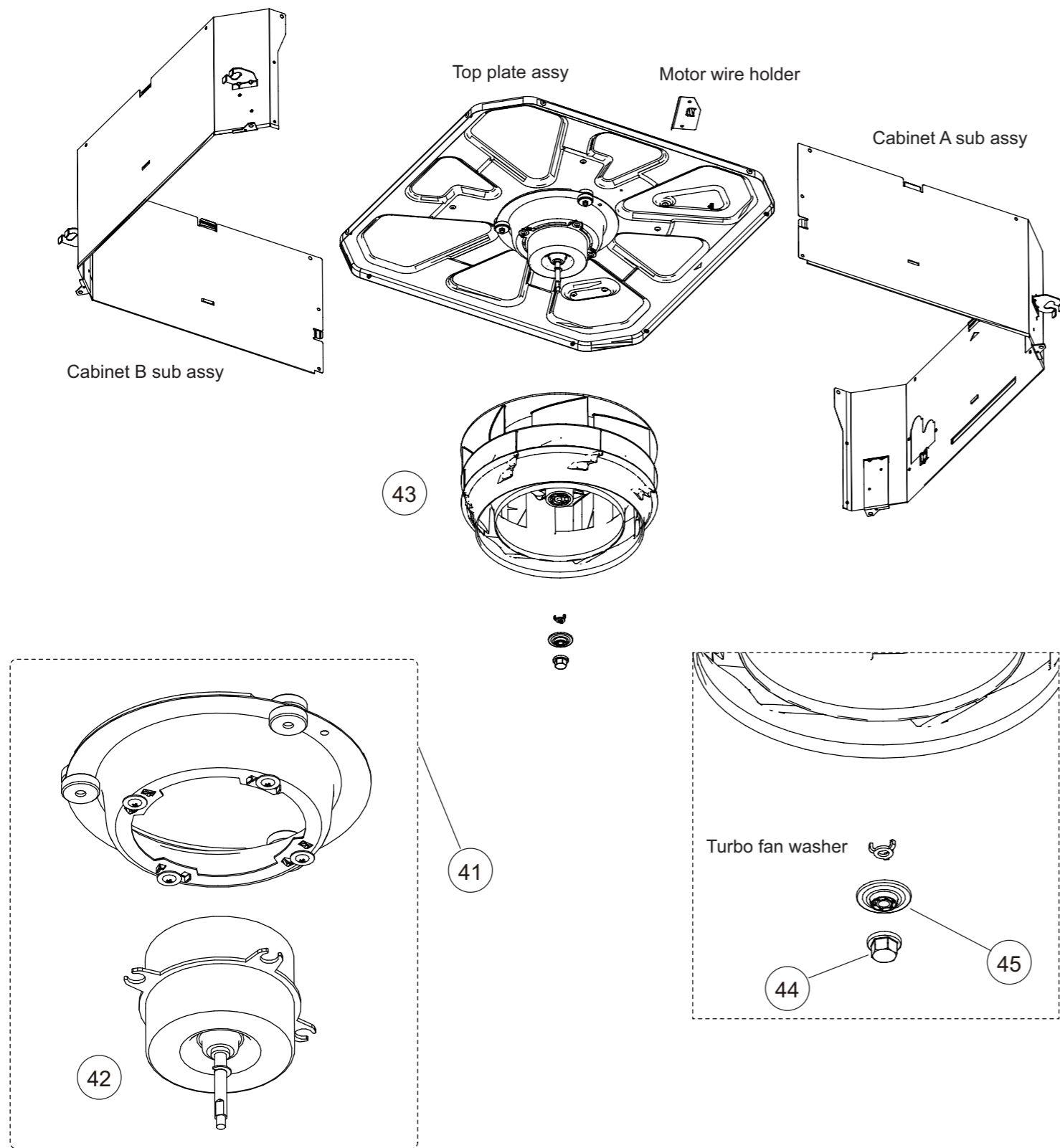

Ref.	Description	Part number
41	Fan motor sub assy	9375719012
42	Fan motor	9602436019
43	2 stage turbo fan assy	9375480011
44	Shaft cap	9377807014
45	Washer cover	9377811011

3. Outdoor unit parts list

3-1. Models: AOYG09KATA and AOYG12KATA

■ Exterior parts and chassis

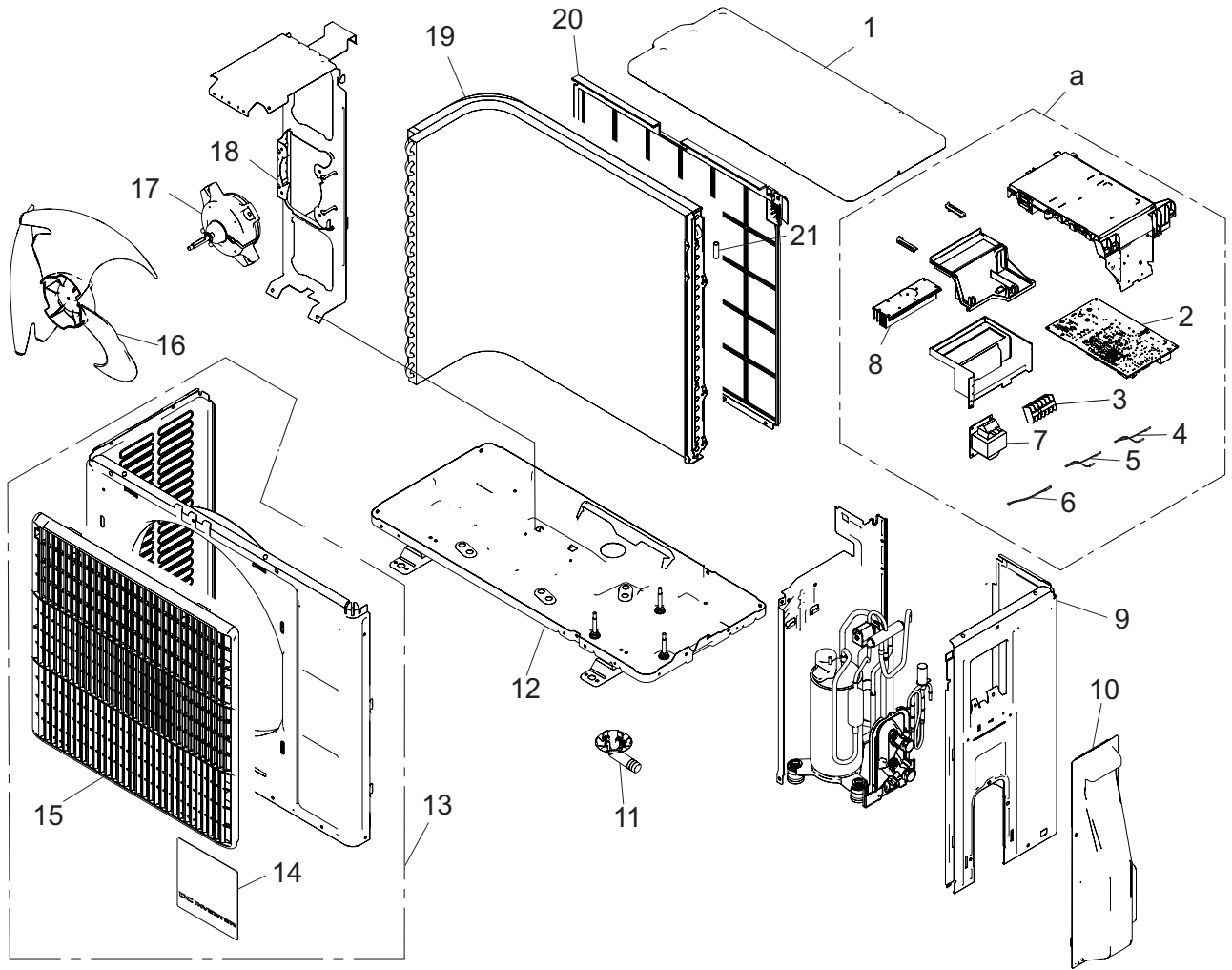

TECHNICAL DATA
AND PARTS LIST

TECHNICAL DATA
AND PARTS LIST

Item no.	Part no.	Part name	Service part
1	9322556080	Top panel assy	◆
2	9710924415	Main PCB	◆
3	9900435028	Terminal	◆
4	9900727062	Thermistor assy	◆
5	9900565060	Thermistor assy (outdoor temp)	◆
6	9900984014	Heat exchanger thermistor	◆
7	9900583019	Reactor assy	◆
8	9322418005	Heat sink	◆
9	9322552112	Cabinet right assy	◆
10	9322570000	Switch cover assy	◆
11	9322144003	Drain pipe	◆
12	9322308023	Base assy	◆
13	9322555106	Front panel assy	◆
14	9387859003	Emblem	◆
15	9322135001	Blow grille	◆
16	9322136008	Propeller fan	◆
17	9603657017	Brushless motor	◆
18	9322553003	Motor bracket assy	◆
19	9322272010	Condenser total assy (for 09 model)	◆
	9322273000	Condenser total assy (for 12 model)	◆
20	9322811004	Protective net	◆
21	9331404006	Thermistor holder	◆
<i>a</i>	—	Inverter assy	—

Compressor

TECHNICAL DATA
AND PARTS LIST

TECHNICAL DATA
AND PARTS LIST

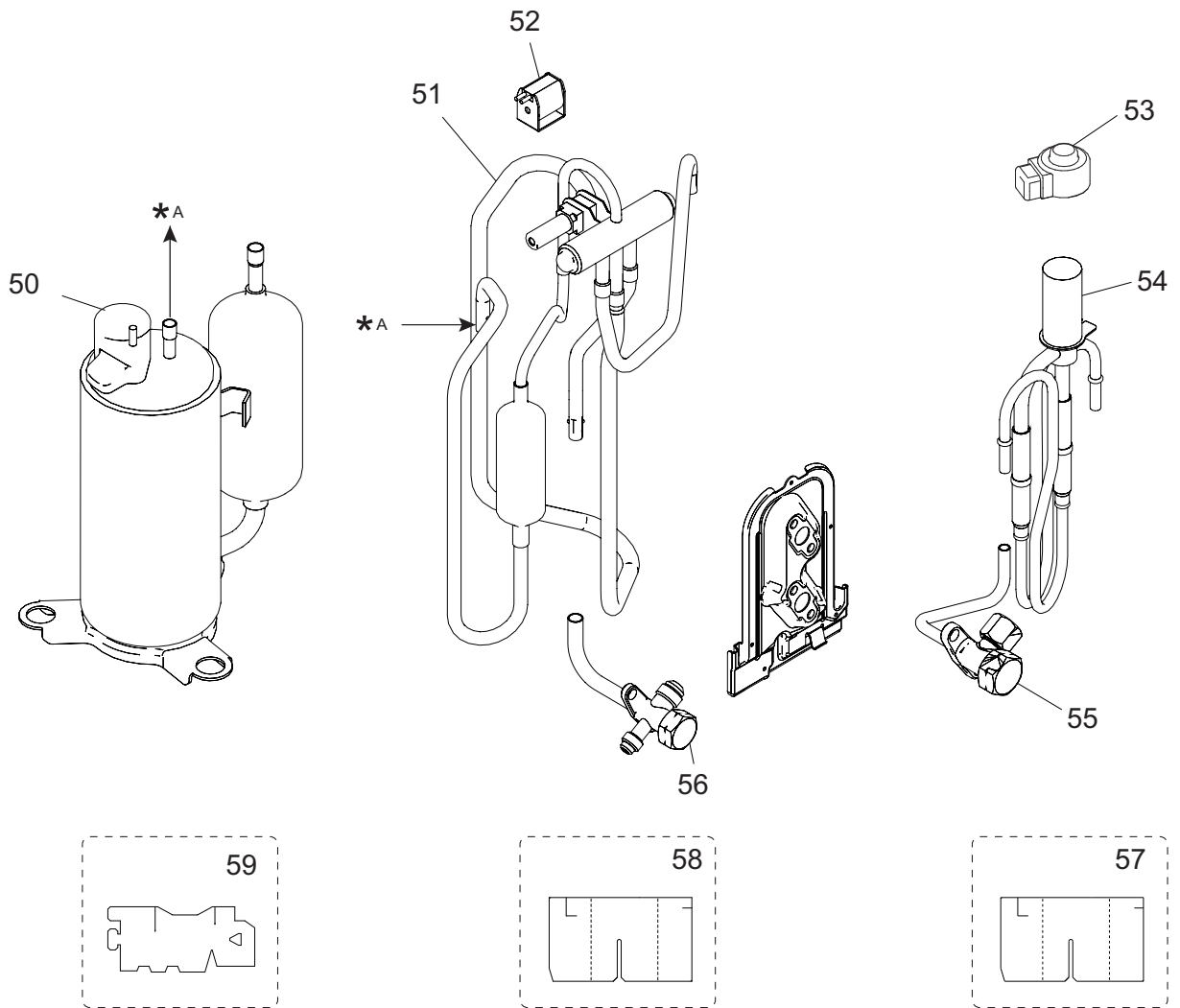

Item no.	Part no.	Part name	Service part
50	9322423009	Compressor assy (for 09 model)	◆
	9322425003	Compressor assy (for 12 model)	◆
51	9322392008	4 way valve assy	◆
52	9970110153	Solenoid	◆
53	9970173011	Expansion valve coil	◆
54	9322403001	Pulse motor valve	◆
55	9322474025	2 way valve assy	◆
56	9318254051	3 way valve assy	◆
57	9322389008	S insurator H	◆
58	9322388001	S insurator F	◆
59	9322387004	S insurator B	◆

3-2. Models: AOYG14KATA and AOYG18KATA

■ Exterior parts and Chassis

TECHNICAL DATA
AND PARTS LIST

TECHNICAL DATA
AND PARTS LIST

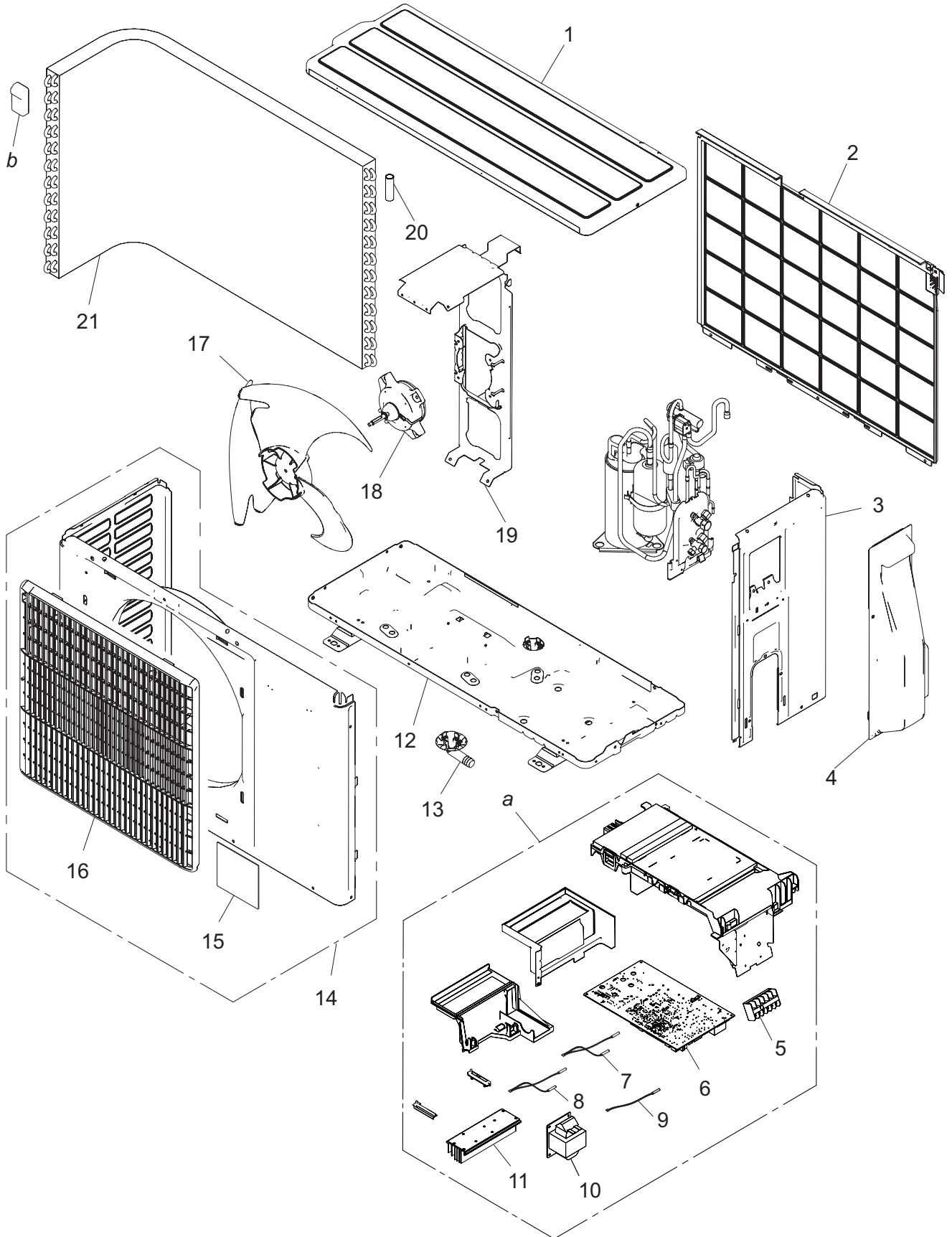

Item no.	Part no.	Part name	Service part
1	9322556028	Top panel assy	◆
2	9322811011	Protective net	◆
3	9322552020	Cabinet right assy	◆
4	9322570000	Switch cover assy	◆
5	9900435028	Terminal	◆
6	9710924422	Main PCB	◆
7	9900727062	Thermistor assy	◆
8	9900565060	Thermistor (Outdoor temp.)	◆
9	9900984014	Heat exchanger thermistor	◆
10	9900583019	Reactor assy (for 14 model)	◆
	9900963019	Reactor assy (for 18 model)	◆
11	9322418005	Heat sink	◆
12	9322314024	Base assy	◆
13	9322144003	Drain pipe	◆
14	9322555014	Front panel assy	◆
15	9319151007	Emblem	◆
16	9322135001	Blow grille	◆
17	9322136008	Propeller fan	◆
18	9603657017	Brushless motor	◆
19	9322553010	Motor bracket assy	◆
20	9331404006	Thermistor holder	◆
21	9322275004	Condenser total assy	◆
<i>a</i>	—	Inverter assy	—
<i>b</i>	—	Hair pin cushion	—

Compressor

TECHNICAL DATA
AND PARTS LIST

TECHNICAL DATA
AND PARTS LIST

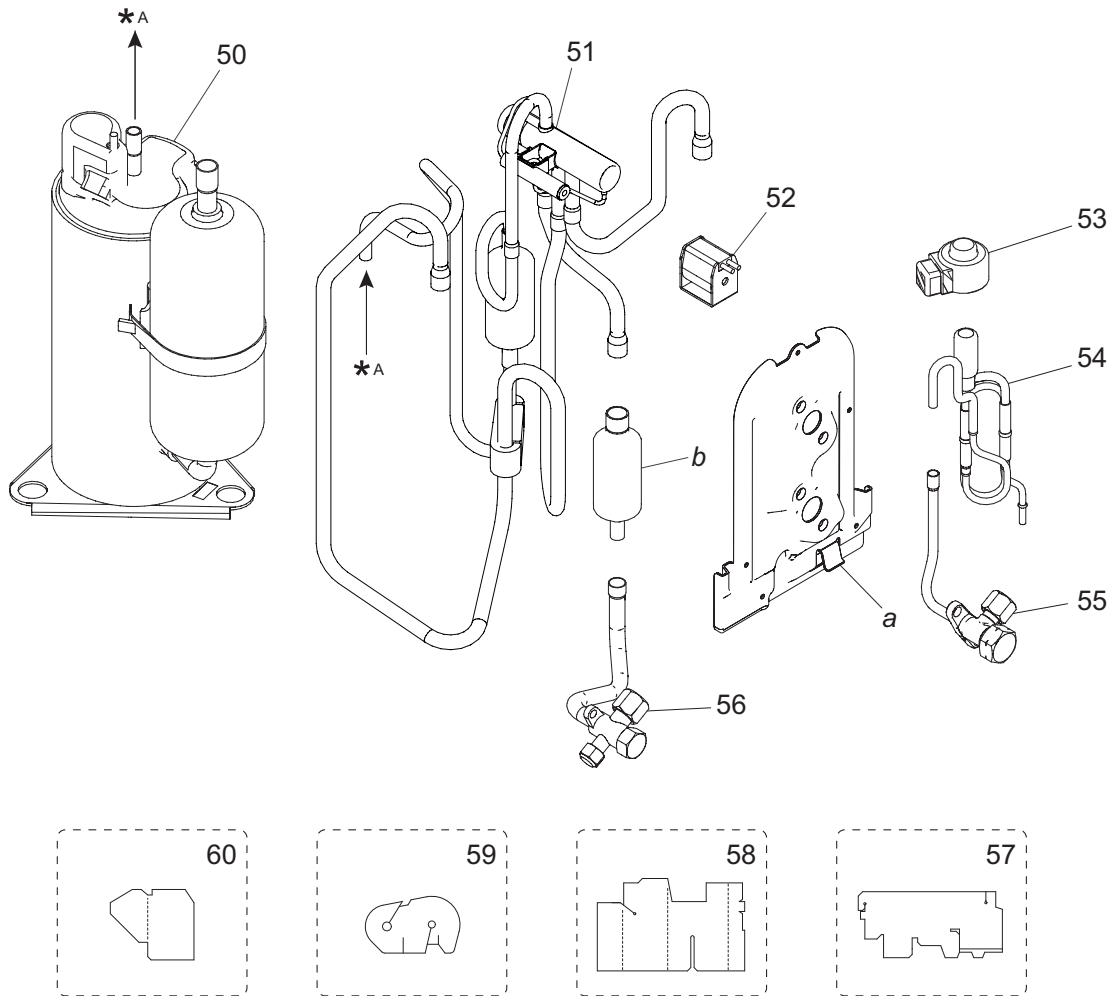

Item no.	Part no.	Part name	Service part
50	9322427007	Compressor assy (for 14 model)	◆
	9322429001	Compressor assy (for 18 model)	◆
51	9322444011	4-way valve assy	◆
52	9970110160	Solenoid	◆
53	9970173011	Expansion valve coil	◆
54	9322463029	Pulse motor valve assy	◆
55	9322474001	2-way valve assy	◆
56	9322475008	3-way valve assy (for 14 model)	◆
	9387831016	3-way valve assy (for 18 model)	◆
57	9322535009	S-insulator B	◆
58	9322536006	S-insulator F	◆
59	9322537003	S-insulator H	◆
60	9323045002	S-insulator V	◆
a	—	Valve bracket	—
b	—	Muffler	—

3-3. Model: AOYG22KATA

■ Exterior parts and Chassis

TECHNICAL DATA
AND PARTS LIST

TECHNICAL DATA
AND PARTS LIST

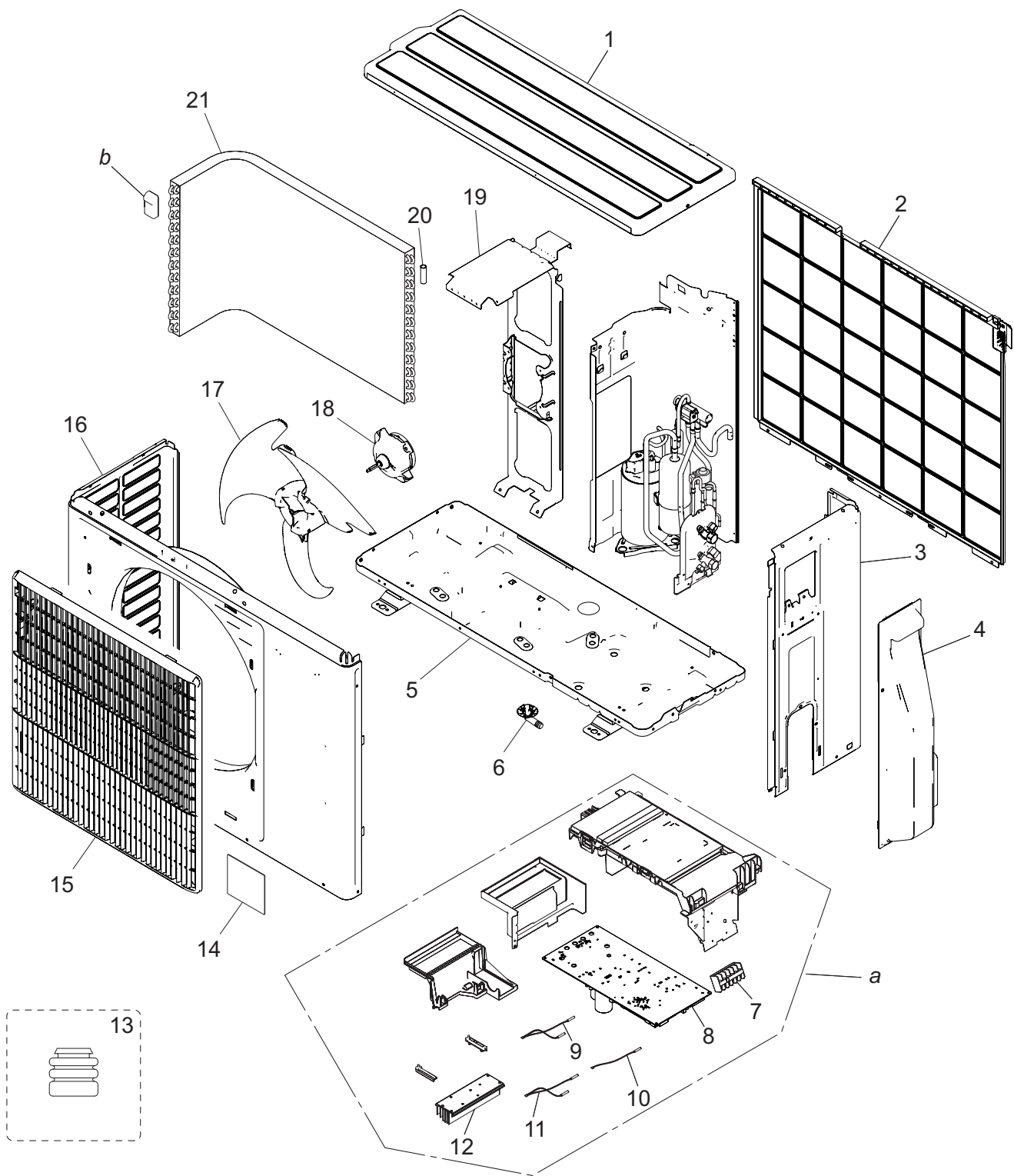

Item no.	Part no.	Part name	Service part
1	9322556028	Top panel assy	◆
2	9322811028	Protective net assy	◆
3	9322552099	Cabinet right assy	◆
4	9322570024	Switch cover assy	◆
5	9322314024	Base assy	◆
6	9322144003	Drain pipe	◆
7	9900435028	Terminal	◆
8	9710802331	Main PCB	◆
9	9900727079	Thermistor assy	◆
10	9900984014	Heat exchanger thermistor	◆
11	9900565060	Thermistor assy (Outdoor temp.)	◆
12	9322420039	Heat sink	◆
13	9322386007	Cushion rubber	◆
14	9319151007	Emblem	◆
15	9322149008	Blow grille	◆
16	9322555021	Front panel assy	◆
17	9322150004	Propeller fan	◆
18	9603601003	Brushless motor	◆
19	9322553027	Motor bracket assy	◆
20	9317089616	Condenser total assy	◆
21	9331404006	Thermistor holder pipe	◆
<i>a</i>	—	Inverter assy	—
<i>b</i>	—	Hair pin cushion	—

Compressor

TECHNICAL DATA
AND PARTS LIST

TECHNICAL DATA
AND PARTS LIST

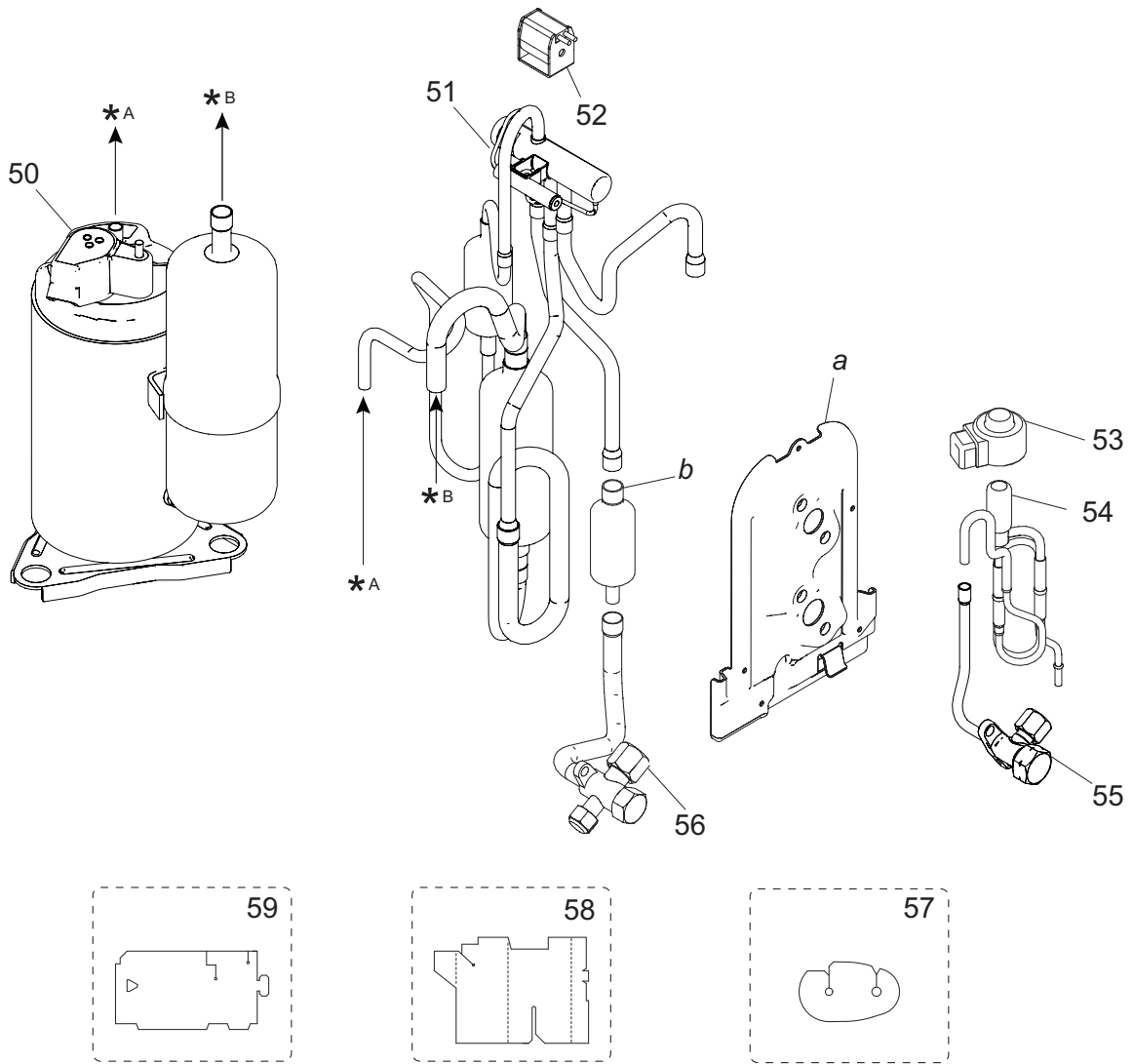





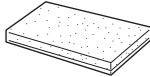
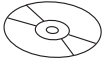

Item no.	Part no.	Part name	Service part
50	9810523006	Compressor	◆
51	9322783028	4-way valve assy	◆
52	9970110160	Solenoid	◆
53	9970173028	Expansion valve coil	◆
54	9322463029	Pulse motor valve assy	◆
55	9322474001	2-way valve assy	◆
56	9387831016	3-way valve assy	◆
57	9322501004	S-insulator H	◆
58	9322847003	S-insulator F	◆
59	9322500007	S-insulator B	◆
<i>a</i>	—	Valve bracket	—
<i>b</i>	—	Muffler	—

4. Accessories

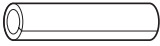
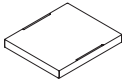
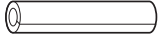

4-1. Indoor unit

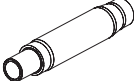
■ Models: AUXG09KVLA, AUXG12KVLA, AUXG14KVLA, AUXG18KVLA, and AUXG22KVLA

Part name	Exterior	Q'ty	Part name	Exterior	Q'ty
Operating manual		1	Drain hose insulation		1
Operating manual (CD-ROM)		1	Hose band		1
Installation manual		1	Coupler heat insulation (large)		1
Template (Carton top)		1	Coupler heat insulation (small)		1
M10 nut A (with flange)		4	Cable tie		2
M10 nut B (with spring lock washer)		4	Wire crammer		1
Drain hose		1			

4-2. Outdoor unit



■ Models: AOYG09KATA and AOYG12KATA, AOYG14KATA and AOYG18KATA, and AOYG22KATA



Part name	Exterior	Q'ty	Part name	Exterior	Q'ty
Installation manual		1	Drain pipe		1

5. Optional parts

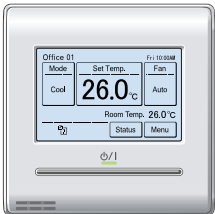
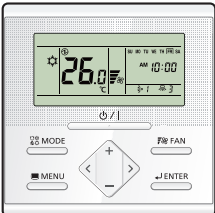
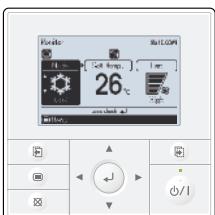
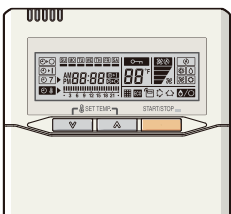
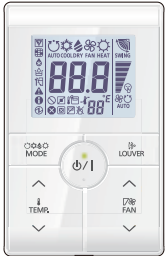
5-1. Indoor unit

■ Controllers

Exterior	Part name	Model name	Summary
	Wired remote controller	UTU-RNRYZ*	Easy finger touch operation with LCD panel. Backlit LCD enables easy operation in a dark room. Wire type: Non-polar 2-wire
	Wired remote controller	UTU-RLRY	High visibility and easy operation. Room temperature can be accurately controlled using the built-in thermo sensor. Wire type: Non-polar 2-wire
	Wired remote controller	UTU-RVNYM	Large and full-dot liquid crystal screen, wide and large keys easy to press, user-intuitive arrow key. Wire type: Polar 3-wire
	Wired remote controller	UTU-RNNYM	Room temperature can be controlled by detecting the temperature accurately with built-in thermo sensor. Wire type: Polar 3-wire
	Simple remote controller	UTU-RSRY	Compact remote controller concentrates on the basic functions such as Start/Stop, fan control, temperature setting, and operation mode. Wire type: Non-polar 2-wire
	Simple remote controller	UTU-RHRY	Compact remote controller concentrates on the basic functions such as Start/Stop, fan control, and temperature setting. Wire type: Non-polar 2-wire





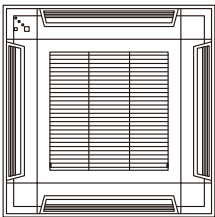

Exterior	Part name	Model name	Summary
	Simple remote controller	UTY-RSNYM	Compact remote controller concentrates on the basic functions such as Start/Stop, fan control, temperature setting, and operation mode. Wire type: Polar 3-wire
	Wireless remote controller	UTY-LNTY	Unit control is performed by wireless remote controller.

NOTE: Available functions may differ by the remote controller. For details, refer to the operation manual.

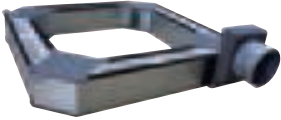
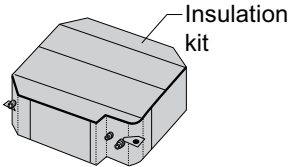

Exterior	Part name	Model name	Summary
	Cassette grille	UTG-UFYF-W	This cassette grille can be installed appropriately on the grid type ceiling common in the office.

Others

Exterior	Part name	Model name	Summary
	External connect kit	UTY-XWZXZG	Use to connect with various peripheral devices and air conditioner PCB. For control output port.
	Air outlet shutter plate	UTR-YDZB	Installed at the air outlet when 3-directions mode is performed.
	Fresh-air intake kit	UTZ-VXAA	By attaching Fresh-air intake kit to the indoor unit, it can be taken in fresh air of up to 10% of "high" air volume of the indoor unit.
	Insulation for high humidity	UTZ-KXGC	Install when the under-roof condition is expected to be the humidity of over 80% and the temperature of over 30 °C.
	Wireless LAN adapter	UTY-TFSXZ1	Remotely manage an air conditioning system using mobile devices such as smartphones and tablets. For connection indoor unit with UART interface.
	Modbus converter	UTY-VMSX	For connection between indoor unit with UART interface and a Modbus open network.
	KNX converter	UTY-VKSX	For connection between indoor unit with UART interface and a KNX open network.
	External switch controller	UTY-TERX	Air conditioner switching can be controlled by connecting other external sensor switches.

NOTE: Combined use of following optional parts and Wireless LAN adapter (UTY-TFSXZ1) is not allowed.

- Modbus converter
- KNX converter

6. Refrigerant system diagrams

6-1. Models: AOYG09KATA and AOYG12KATA

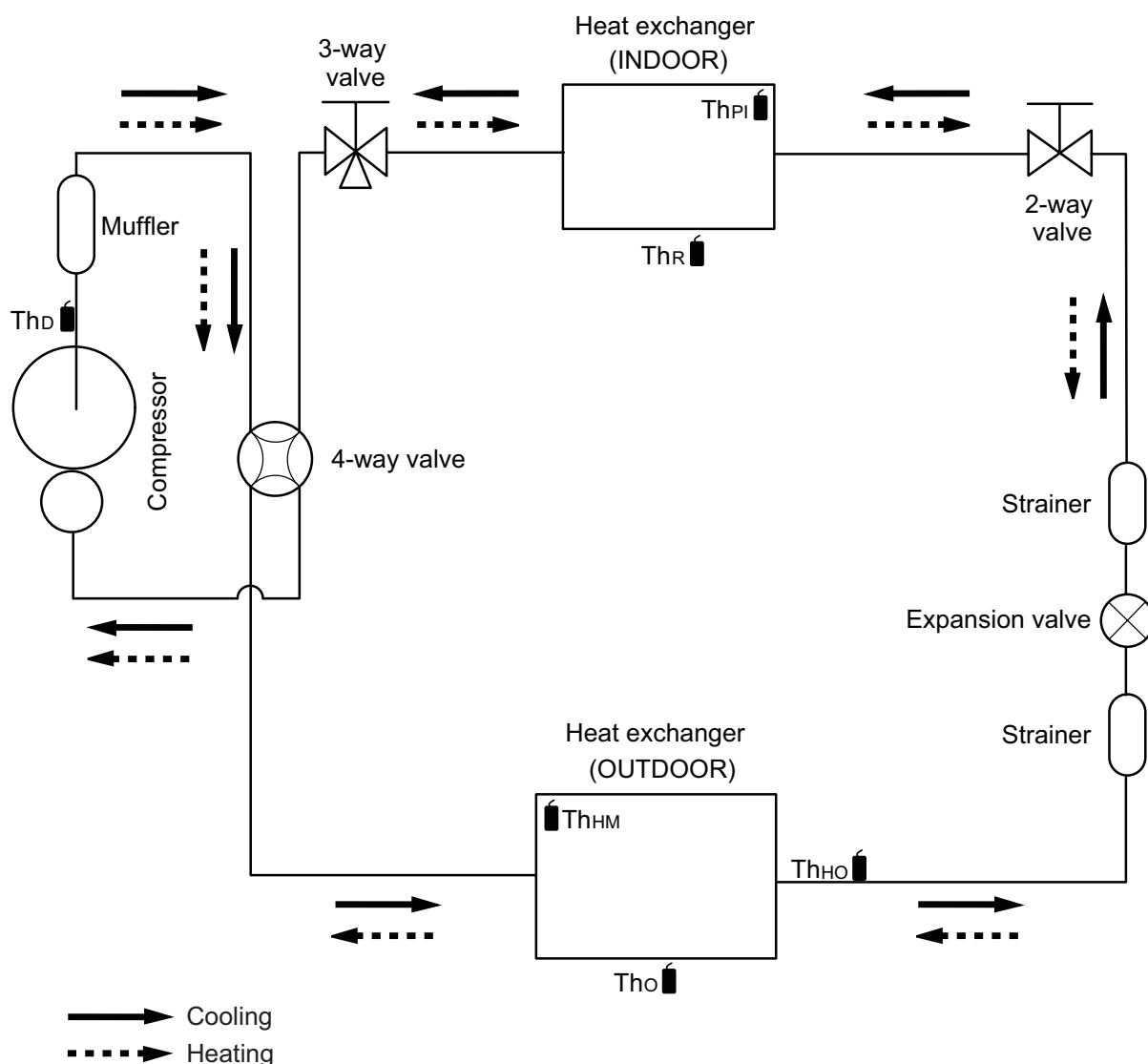

Th_D : Thermistor (Discharge temperature)

Th_o : Thermistor (Outdoor temperature)

Th_{HO} : Thermistor (Heat exchanger out temperature)

Th_{HM} : Thermistor (Heat exchanger middle temperature)

Th_R : Thermistor (Room temperature)

Th_{PI} : Thermistor (Pipe temperature)

6-2. Models: AOYG14KATA and AOYG18KATA

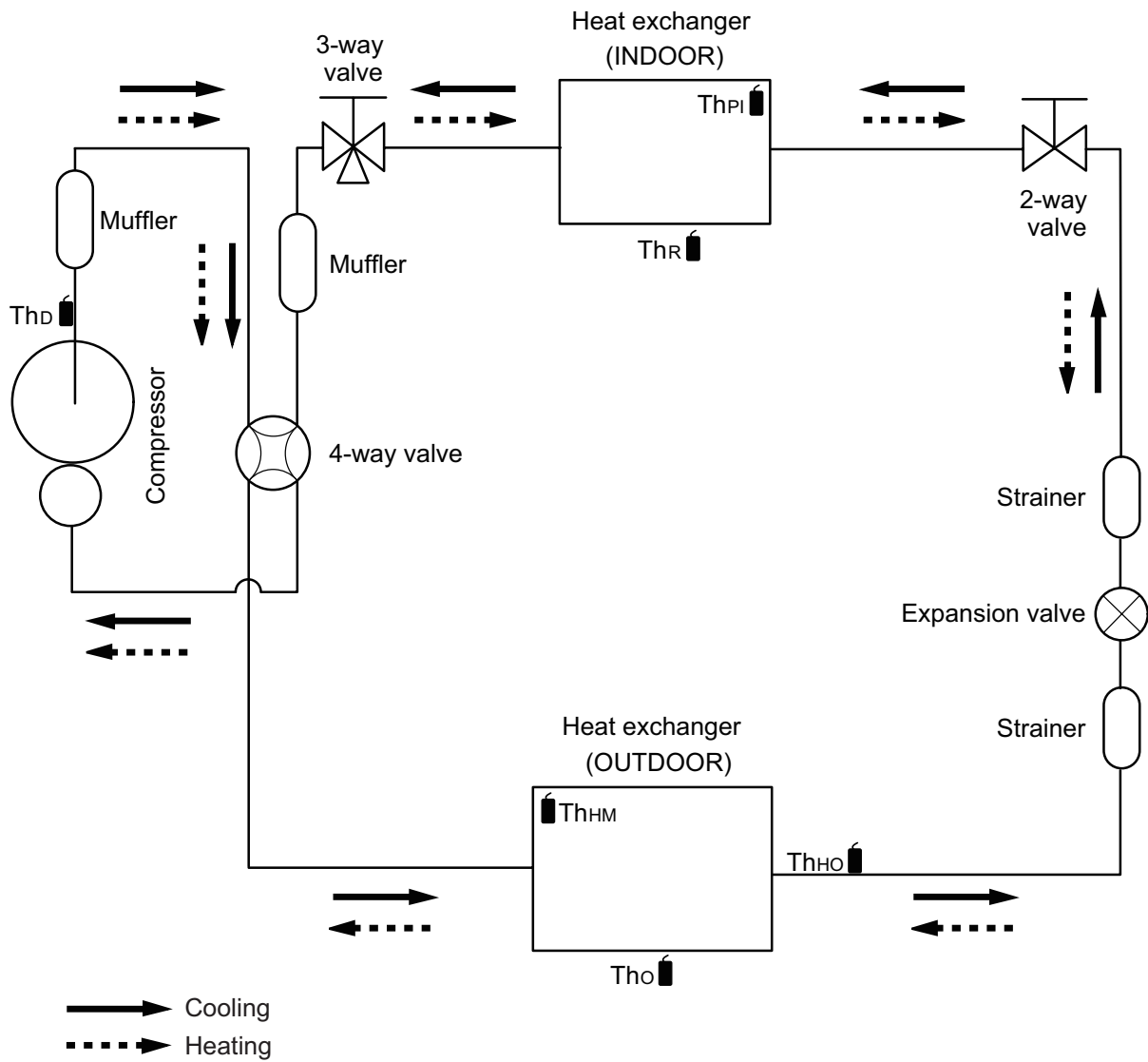

Th_D : Thermistor (Discharge temperature)

Th_O : Thermistor (Outdoor temperature)

Th_{HO} : Thermistor (Heat exchanger out temperature)

Th_{HM} : Thermistor (Heat exchanger middle temperature)

Th_R : Thermistor (Room temperature)

Th_{PI} : Thermistor (Pipe temperature)

6-3. Model: AOYG22KATA

TECHNICAL DATA
AND PARTS LIST

TECHNICAL DATA
AND PARTS LIST

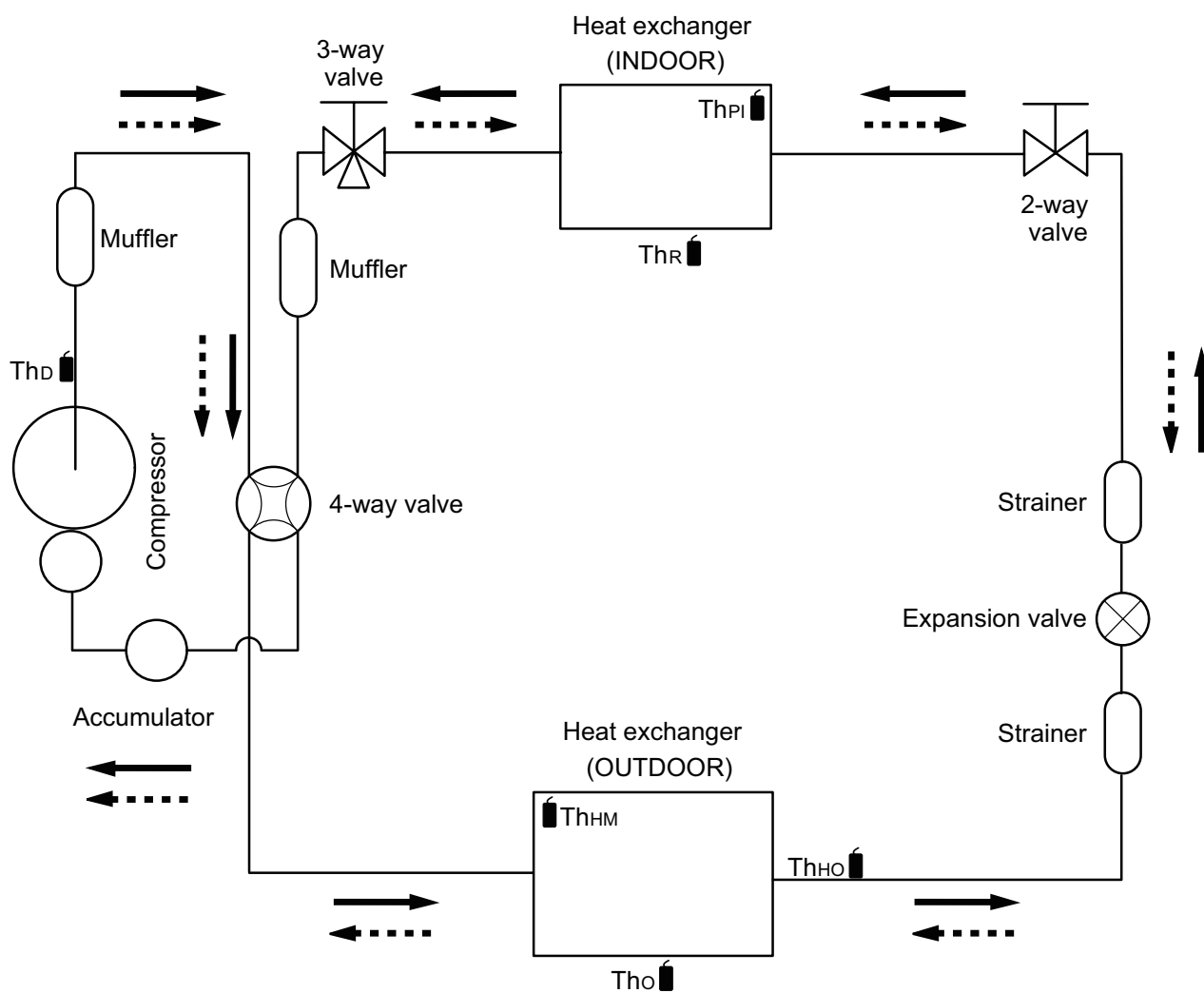

Cooling
 Heating

- Th_D : Thermistor (Discharge temperature)
- Th_O : Thermistor (Outdoor temperature)
- Th_{HO} : Thermistor (Heat exchanger out temperature)
- Th_{HM} : Thermistor (Heat exchanger middle temperature)
- Th_R : Thermistor (Room temperature)
- Th_{PI} : Thermistor (Pipe temperature)

7. Wiring diagrams

7-1. Indoor unit

■ Models: AUXG09KVLA, AUXG12KVLA, AUXG14KVLA, AUXG18KVLA, and AUXG22KVLA

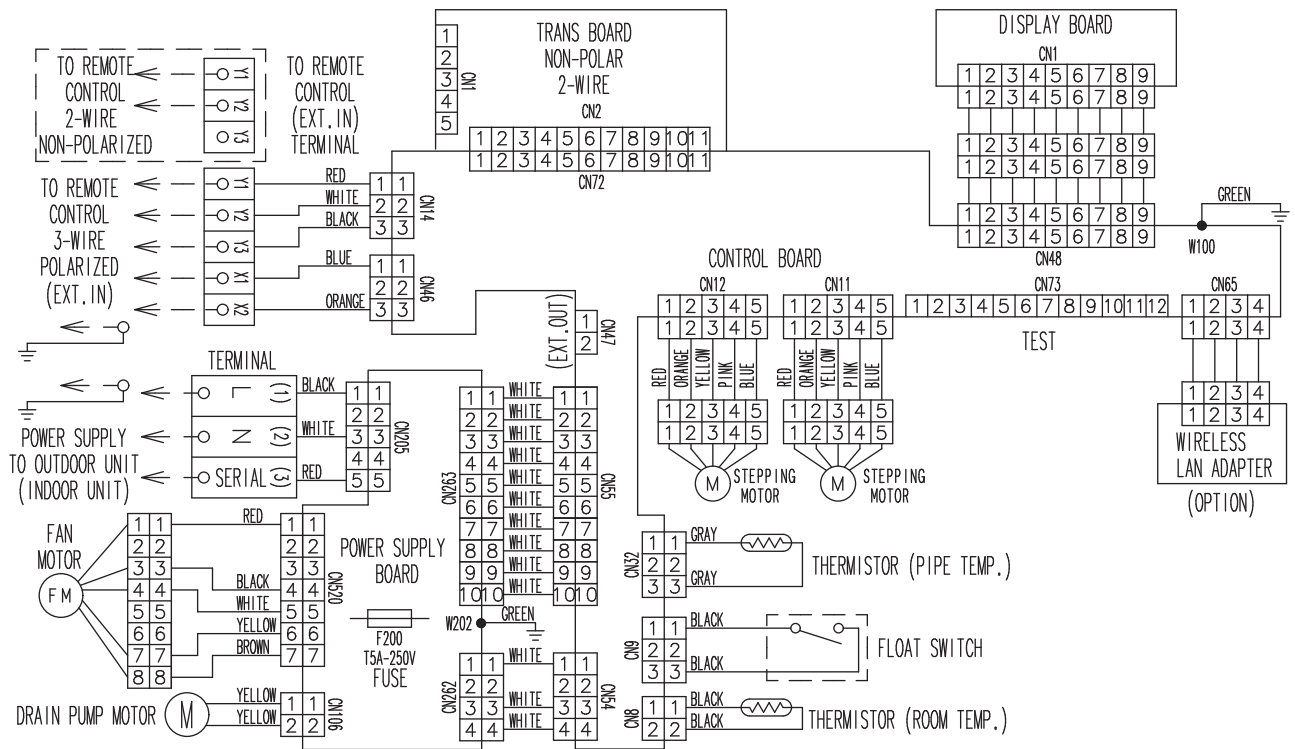

TECHNICAL DATA AND PARTS LIST

TECHNICAL DATA AND PARTS LIST

7-2. Outdoor unit

Models: AOYG09KATA, AOYG12KATA, AOYG14KATA, and AOYG18KATA

TECHNICAL DATA AND PARTS LIST

TECHNICAL DATA AND PARTS LIST

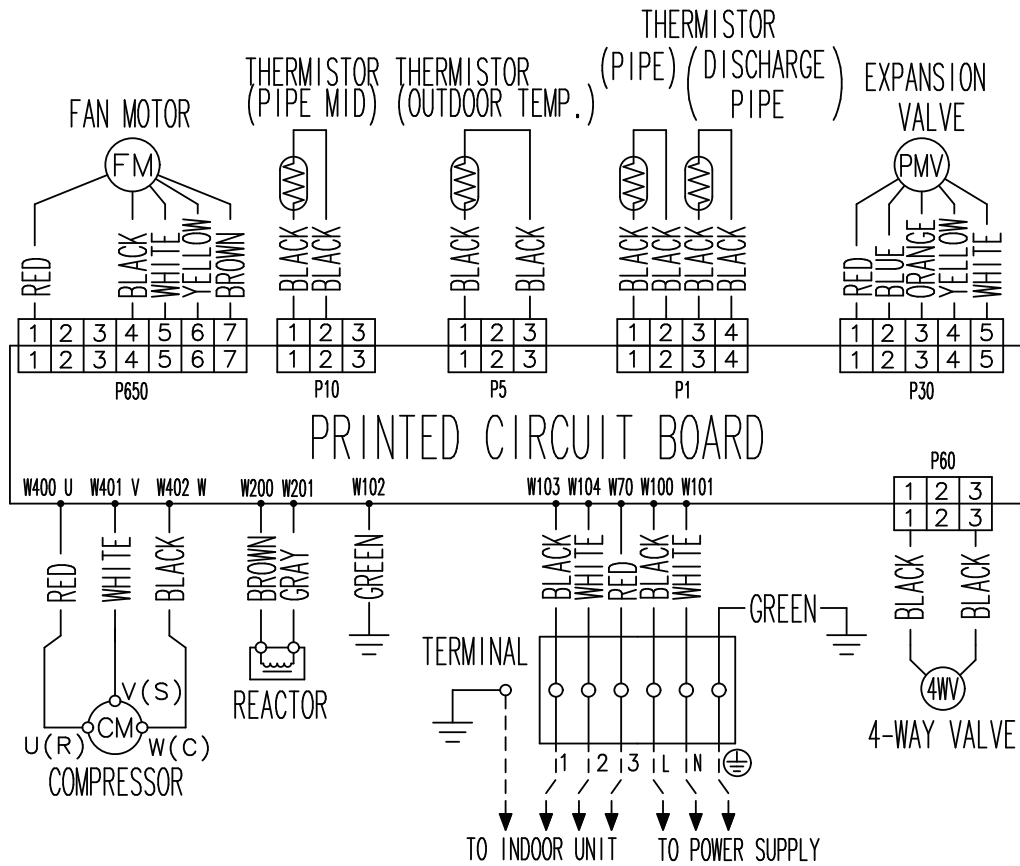

Model: AOYG22KATA

TECHNICAL DATA
AND PARTS LIST

TECHNICAL DATA
AND PARTS LIST

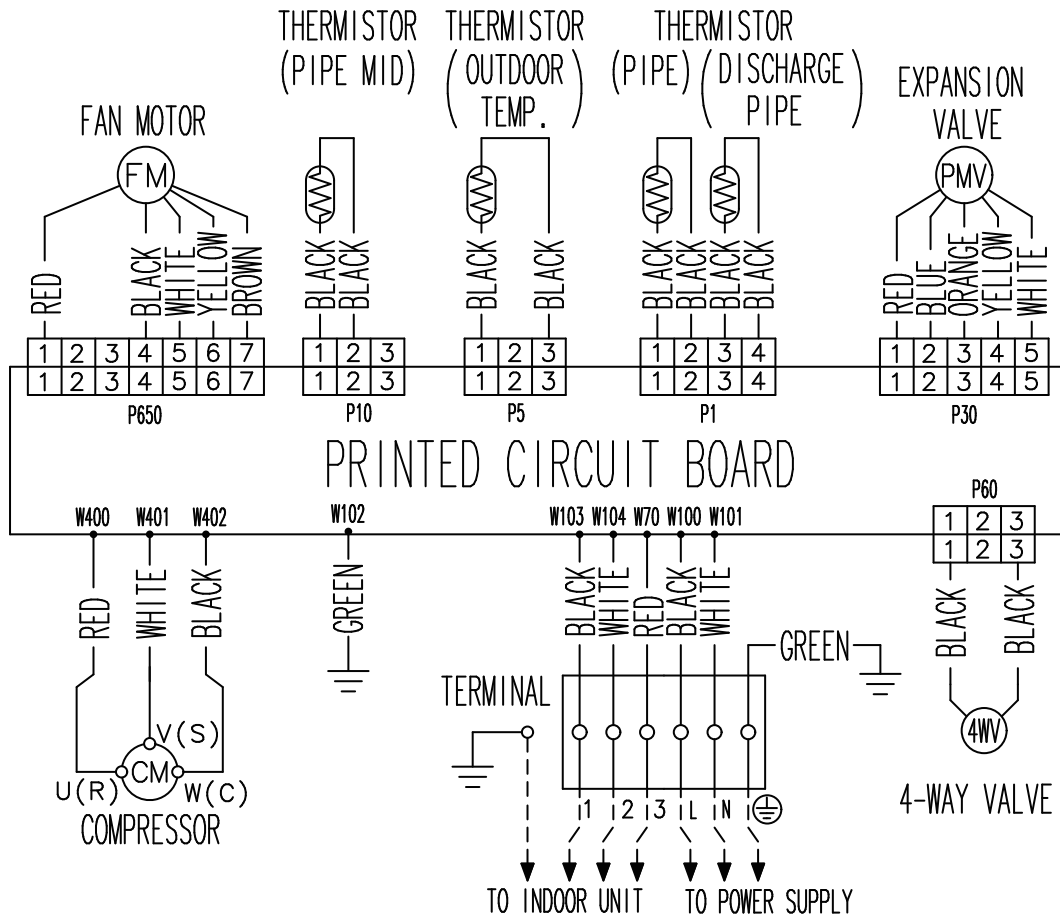

8-2. Models: AOYG09KATA, AOYG12KATA, AOYG14KATA, and AOYG18KATA

TECHNICAL DATA AND PARTS LIST

TECHNICAL DATA AND PARTS LIST

INVERTER ASSEMBLY
 AOYG09KATA : EZ-019AHUE
 AOYG12KATA : EZ-019BHUE
 AOYG14KATA : EZ-019CHUE
 AOYG18KATA : EZ-019DHUE

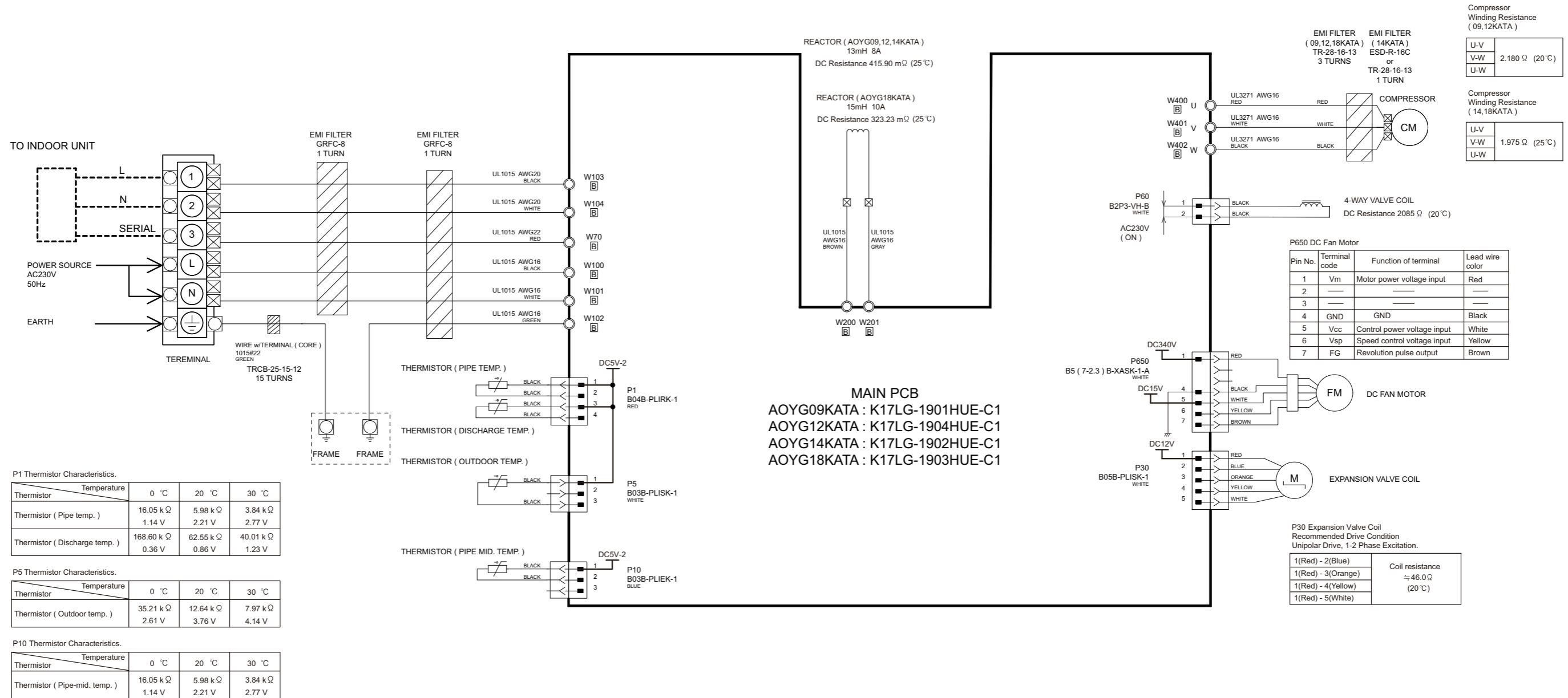

8-3. Model: AOYG22KATA

TECHNICAL DATA AND PARTS LIST

TECHNICAL DATA AND PARTS LIST

INVERTER ASSEMBLY EZ-019EHUE

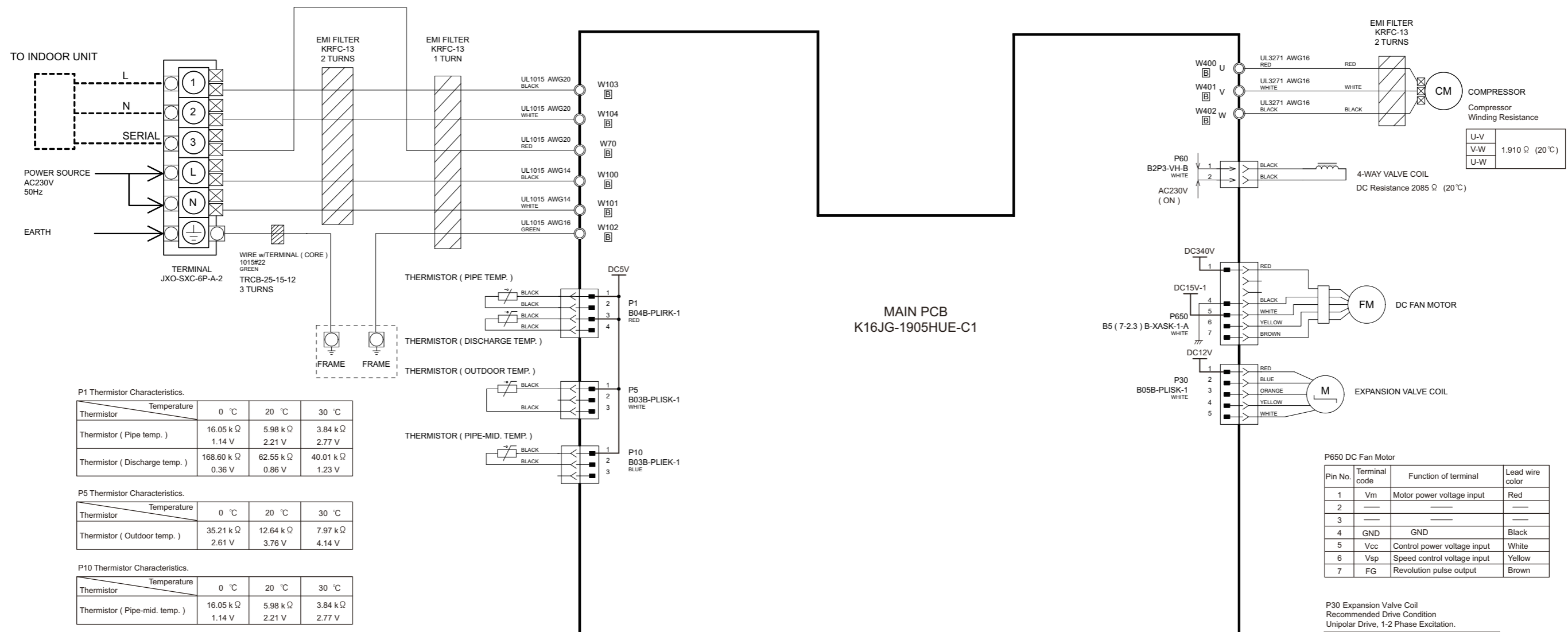

P1 Thermistor Characteristics.

Thermistor	Temperature	0 °C	20 °C	30 °C
Thermistor (Pipe temp.)		16.05 k Ω	5.98 k Ω	3.84 k Ω
		1.14 V	2.21 V	2.77 V
Thermistor (Discharge temp.)		168.60 k Ω	62.55 k Ω	40.01 k Ω
		0.36 V	0.86 V	1.23 V

P5 Thermistor Characteristics.

Thermistor	Temperature	0 °C	20 °C	30 °C
Thermistor (Outdoor temp.)		35.21 k Ω	12.64 k Ω	7.97 k Ω
		2.61 V	3.76 V	4.14 V

P10 Thermistor Characteristics.

Thermistor	Temperature	0 °C	20 °C	30 °C
Thermistor (Pipe-mid. temp.)		16.05 k Ω	5.98 k Ω	3.84 k Ω
		1.14 V	2.21 V	2.77 V

Compressor Winding Resistance

U-V	1.910 Ω (20 °C)
V-W	
U-W	

P650 DC Fan Motor

Pin No.	Terminal code	Function of terminal	Lead wire color
1	Vm	Motor power voltage input	Red
2	—	—	—
3	—	—	—
4	GND	GND	Black
5	Vcc	Control power voltage input	White
6	Vsp	Speed control voltage input	Yellow
7	FG	Revolution pulse output	Brown

P30 Expansion Valve Coil Recommended Drive Condition
Unipolar Drive, 1-2 Phase Excitation.

1(Red) - 3(Blue)	Coil resistance ≈ 46.0 Ω (20 °C)
1(Red) - 4(Orange)	
1(Red) - 5(Yellow)	
1(Red) - 6(White)	