

BACnet Gateway for VRF System

UTY-VBGX

INSTRUCTION MANUAL

Issue Date: 03/2021
r1.4.0 eng

FUJITSU GENERAL LIMITED

PART No. 9708569239-02

© FUJITSU GENERAL LIMITED 2021 All rights reserved

Information in this document is subject to change without notice. The software described in this document is furnished under a license agreement or nondisclosure agreement. No part of this publication may be reproduced, stored in a retrieval system or transmitted in any form or any means electronic or mechanical, including photocopying and recording for any purpose other than the purchaser's personal use without the written permission of Fujitsu General Limited.

FUJITSU GENERAL LIMITED

3-3-17, Suenaga, Takatsu-ku, Kawasaki 213-8502, Japan

TRADEMARKS

All trademarks and trade names used in this document are acknowledged to be the copyright of their respective holders.

BACnet is a trademark or registered trademark of the American Society of Heating, Refrigerating and Air-Conditioning Engineers, Inc.

LICENSE AGREEMENT FOR “CONFIGURATION TOOL OF BACnet GATEWAY FOR VRF SYSTEM” IMPORTANT-READ CAREFULLY

This “CONFIGURATION TOOL of BACnet GATEWAY for VRF SYSTEM” License Agreement (“LICENSE AGREEMENT”) is a legal agreement between you and Fujitsu General Limited (“FGL”) for the use of CONFIGURATION TOOL for VRF BACnet GATEWAY products consisting of computer software and online, electronic and/or printed documentation (collectively “SOFTWARE PRODUCT” or “SOFTWARE”). By installing, copying, or otherwise using the SOFTWARE PRODUCT, you accept to be bound by all of the terms and conditions of this LICENSE AGREEMENT. If you do not agree to any of the terms and conditions of this LICENSE AGREEMENT, you shall not use the SOFTWARE PRODUCT and shall promptly return the SOFTWARE PRODUCT to the place where you have obtained it.

1. COPYRIGHT AND OWNERSHIP.

The SOFTWARE PRODUCT is protected by copyright laws and international copyright treaties as well as other intellectual property laws and treaties. The SOFTWARE PRODUCT is licensed to you, not sold. FGL owns the title, copyright, and other intellectual property rights in the SOFTWARE PRODUCT.

2. GRANT OF LICENSE.

FGL hereby grants you the limited, non-exclusive and non-transferable rights to use the SOFTWARE PRODUCT only for the purpose of controlling the VRF air-conditioning system products (VRF) provided you comply with all terms and conditions of this LICENSE AGREEMENT.

3. DESCRIPTION OF OTHER RIGHTS AND LIMITATIONS.

(1) LIMITATIONS ON REVERSE ENGINEERING, DECOMPILATION, AND DISASSEMBLY.

You shall not modify, alter, reverse engineer, decompile, or disassemble the SOFTWARE PRODUCT. You shall not alter or remove any copyright, trademark or other proprietary notice of FGL from the SOFTWARE PRODUCT.

(2) NO RENTAL, LEASE AND TRANSFER.

You shall not rent, lease or transfer the SOFTWARE PRODUCT to any person and/or entity (-ies).

(3) TERMINATION.

Without prejudice to any other rights, FGL may terminate this LICENSE AGREEMENT if you fail to comply with any terms and conditions of this LICENSE AGREEMENT. In such an event, you shall promptly return all originals and copies of the SOFTWARE PRODUCT to FGL.

4. INSTALLATION AND USE OF SOFTWARE PRODUCT.

You may install and use the enclosed SOFTWARE PRODUCT on any computer under one of the operating environment identified in the documentation accompanying the SOFTWARE. The infrastructure necessary to use the SOFTWARE PRODUCT (PC, accessories, etc.) shall be prepared separately by you.

5. NO WARRANTY.

FGL EXPRESSLY DISCLAIMS ANY WARRANTY FOR THE SOFTWARE PRODUCT. THE SOFTWARE PRODUCT IS PROVIDED “AS IS” WITHOUT WARRANTY OF ANY KIND, EITHER EXPRESSED OR IMPLIED, INCLUDING, WITHOUT LIMITATION, STATUTORY WARRANTIES, MERCHANTABILITY OR FITNESS FOR A PARTICULAR PURPOSE OR NON-INFRINGEMENT OF THIRD PARTY’S RIGHTS. THE ENTIRE RISKS ARISING OUT OF USE OR PERFORMANCE OF THE SOFTWARE PRODUCT REMAIN WITH YOU. HOWEVER, IF YOU NOTIFY FGL OF PHYSICAL DEFECT OF THE MEDIA CONTAINING SOFTWARE WITHIN (90) DAYS FOLLOWING YOUR RECEIPT OF THE SOFTWARE PRODUCT, FGL WILL REPLACE THE DEFECTIVE MEDIA WITH NEW MEDIA.

6. LIMITATION OF LIABILITY.

IN NO EVENT SHALL FGL BE LIABLE TO YOU OR TO ANY THIRD PARTY FOR ANY DIRECT OR INDIRECT DAMAGES WHATSOEVER (INCLUDING, WITHOUT LIMITATION, DAMAGES FOR LOSS OF BUSINESS PROFIT, BUSINESS INTERRUPTION OR LOSS OF BUSINESS INFORMATION, DAMAGES ARISING OUT OF DATA OR INFORMATION

DERIVED FROM THE SOFTWARE OR ANY OTHER PECUNIARY LOSS), ARISING OUT OF THE USE OR INABILITY TO USE THE SOFTWARE, EVEN IF FGL HAS BEEN ADVISED OF THE POSSIBILITY OF SUCH DAMAGES.

7. ENTIRE AGREEMENT.

This LICENSE AGREEMENT (including any addendum or amendment to this LICENSE AGREEMENT included with the SOFTWARE PRODUCT) is the entire agreement between you and FGL relating to the SOFTWARE PRODUCT and supersedes all prior contemporaneous oral or written communications, proposals and representations with respect to the SOFTWARE PRODUCT or any other subject covered by this LICENSE AGREEMENT.

8. INDEMNITY.

You agree to indemnify and hold FGL, and its subsidiaries, affiliates, officers, agents, co-branders or other partners, and employees, harmless from any damage, claim or demand, including without limitation reasonable attorneys' fees, made by any third party due to or arising out of use of the SOFTWARE PRODUCT.

9. GOVERNING LAW AND JURISDICTION.

This LICENSE AGREEMENT is governed by the laws of JAPAN. You and FGL hereby irrevocably consent to the exclusive jurisdiction and venue in the Tokyo District Court and other higher courts having jurisdiction in Japan for the settlement of disputes arising under or in connection with this LICENSE AGREEMENT.

10. LANGUAGE OF AGREEMENT.

This LICENSE AGREEMENT shall be agreed based on the English language. The text in other language is made for reference purpose only and if there are any discrepancies between the English text and the text in other language, the English text shall prevail.

Gateway for the integration of Fujitsu air conditioning systems in BACnet/IP enabled monitoring and control systems.

Order Code:

UTY-VBGX

Model supporting up to 128 indoor units.

INDEX

1 Description 10

 1.1 Introduction 10

 1.2 Functionality 11

 1.3 Capacity of UTY-VBGX 11

2 Protocol Implementation Conformance Statement 12

 2.1 BACnet Standardized Device Profile (Annex L): 12

 2.2 Segmentation Capability: 12

 2.3 Data Link Layer Options: 12

 2.4 Device Address Binding: 13

 2.5 Networking Options: 13

 2.6 Character Sets Supported 13

 2.7 Gateway 13

3 BACnet Interoperability Building Blocks Supported (BIBBs) 14

 3.1 Data Sharing BIBBs 14

 3.2 Alarm and Event Management BIBBs 14

 3.3 Scheduling BIBBs 15

 3.4 Trending BIBBs 16

 3.5 Device and Network Management BIBBs 16

 3.6 Network Security BIBBs 18

4 Service Types 19

5 Objects 20

 5.1 Supported Object Types 20

 5.2 Member objects 22

 5.2.1 Type: Gateway 22

 5.2.2 Type: Batch objects 22

 5.2.3 Type: Indoor Unit 22

 5.2.4 Type: Outdoor Unit 23

 5.3 Objects and properties 23

 5.3.1 Fujitsu AC Gateway (Device Object Type) 25

 5.3.2 Gateway_ES_Status (Binary Input Object Type) 27

 5.3.3 Gateway_ES_Setting (Binary Output Object Type) 29

 5.3.4 Gateway_Error_Status (Binary Input Object Type) 31

 5.3.5 Gateway_ErrorCode_Status (Multistate Input Object Type) 33

 5.3.6 Batch_SetTemp_Setting (Analog Output Object Type) 35

 5.3.7 Batch_Operation_Setting (Binary Output Object Type) 37

 5.3.8 Batch_OperationMode_Setting (Multistate Output Object Type) 39

 5.3.9 Batch_FanSpeed_Setting (Multistate Output Object Type) 41

 5.3.10 Batch_RC_Prohibition_Setting (Multistate Output Object Type) 43

5.3.11	IU_rr_uu_SetTemp_Status (Analog Input Object Type).....	44
5.3.12	IU_rr_uu_SpaceTemp_Status (Analog Input Object Type).....	46
5.3.13	IU_rr_uu_AutoTempLoLim_Status (Analog Input Object Type).....	48
5.3.14	IU_rr_uu_AutoTempHiLim_Status (Analog Input Object Type)	50
5.3.15	IU_rr_uu_CoolTempLoLim_Status (Analog Input Object Type).....	52
5.3.16	IU_rr_uu_CoolTempHiLim_Status (Analog Input Object Type)	54
5.3.17	IU_rr_uu_HeatTempLoLim_Status (Analog Input Object Type)	56
5.3.18	IU_rr_uu_HeatTempHiLim_Status (Analog Input Object Type)	58
5.3.19	IU_rr_uu_SetTemp_Setting (Analog Output Object Type).....	60
5.3.20	IU_rr_uu_AutoTempLoLim_Setting (Analog Output Object Type).....	63
5.3.21	IU_rr_uu_AutoTempHiLim_Setting (Analog Output Object Type).....	65
5.3.22	IU_rr_uu_CoolTempLoLim_Setting (Analog Output Object Type).....	67
5.3.23	IU_rr_uu_CoolTempHiLim_Setting (Analog Output Object Type).....	69
5.3.24	IU_rr_uu_HeatTempLoLim_Setting (Analog Output Object Type).....	71
5.3.25	IU_rr_uu_HeatTempHiLim_Setting (Analog Output Object Type)	73
5.3.26	IU_rr_uu_Exists_Status (Binary Input Object Type).....	75
5.3.27	IU_rr_uu_Operation_Status (Binary Input Object Type)	77
5.3.28	IU_rr_uu_ThermostatOFF_Status (Binary Input Object Type).....	79
5.3.29	IU_rr_uu_FilterSign_Status (Binary Input Object Type)	81
5.3.30	IU_rr_uu_Emergency_Status (Binary Input Object Type)	83
5.3.31	IU_rr_uu_Error_Status (Binary Input Object Type)	85
5.3.32	IU_rr_uu_TempLimValid_Status (Binary Input Object Type)	87
5.3.33	IU_rr_uu_Operation_Setting (Binary Output Object Type).....	89
5.3.34	IU_rr_uu_ThermostatOFF_Setting (Binary Output Object Type).....	91
5.3.35	IU_rr_uu_Reset_Filter_Setting (Binary Output Object Type).....	93
5.3.36	IU_rr_uu_TempLimValid_Setting (Binary Output Object Type)	95
5.3.37	IU_rr_uu_OperationMode_Status (Multistate Input Object Type)	97
5.3.38	IU_rr_uu_FanSpeed_Status (Multistate Input Object Type)	99
5.3.39	IU_rr_uu_AirFlowDirVT_Status (Multistate Input Object Type).....	101
5.3.40	IU_rr_uu_AirFlowDirHZ_Status (Multistate Input Object Type).....	103
5.3.41	IU_rr_uu_RC_Prohibit_Status (Multistate Input Object Type).....	105
5.3.42	IU_rr_uu_Managed_Mode_Status (Multistate Input Object Type)	106
5.3.43	IU_rr_uu_ErrorCode_Status (Multistate Input Object Type)	108
5.3.44	IU_rr_uu_OperationMode_Setting (Multistate Output Object Type)	110
5.3.45	IU_rr_uu_FanSpeed_Setting (Multistate Output Object Type).....	112
5.3.46	IU_rr_uu_AitFlowDirVT_Setting (Multistate Output Object Type)	114
5.3.47	IU_rr_uu_AirFlowDirHZ_Setting (Multistate Output Object Type).....	116
5.3.48	IU_rr_uu_RC_Prohibit_Setting (Multistate Output Object Type).....	118
5.3.49	OU_rr_uu_Error_Status (Binary Input Object Type)	119
5.3.50	OU_rr_uu_ErrorCode_Status (Multistate Input Object Type).....	121

5.3.51	OU_rr_uu_ForcedOff_Status (Binary Input Object Type)	123
5.3.52	OU_rr_uu_CapacitySave_Status (Multistate Input Object Type)	125
5.3.53	OU_rr_uu_CapacitySave_Setting (Multistate Output Object Type)	127
5.3.54	OU_rr_uu_ForcedOff_Setting (Binary Output Object Type)	129
5.3.55	OU_rr_uu_LowNoiseOp_Status (Multistate Input Object Type)	131
5.3.56	OU_rr_uu_LowNoiseOp_Setting (Multistate Output Object Type)	133
5.3.57	Notification Class Object Type	135
6	Installation	136
6.1	Safety Precautions	136
6.2	Wiring Requirements & Notes	139
6.2.1	Electrical Requirement	139
6.3	Power device	140
6.4	Connect to BACnet	140
6.5	Connect to Fujitsu interface	141
6.6	Connect to PC (Configuration tool)	141
7	Set-up process and troubleshooting	142
7.1	Pre-requisites	142
7.2	Set-up procedure	142
7.3	LEDs status and push buttons	143
8	Configuration Tool for BACnet Gateway (UTY-VBGX)	144
8.1	Introduction	144
8.2	Welcome screen	144
8.3	Connection	145
8.4	Configuration	146
8.4.1	General	146
8.4.2	BACnet Server	147
8.4.3	Fujitsu VRF	148
8.5	Signals	149
8.6	Receive/Send	150
8.7	Diagnostic	152
8.7.1	Console	152
8.7.2	BACnet Server Viewer	152
8.7.3	Fujitsu VRF Viewer	153
8.7.4	Signals Viewer	153
9	AC Unit Types compatibility	154
10	Mechanical & electrical characteristics	154
11	Dimensions	155
12	Annex	156
12.1	Error codes	156
12.2	RC Prohibition	159

1 Description

1.1 Introduction

This document describes the integration of Fujitsu VRF air conditioning systems into BACnet compatible devices and systems using the BACnet Gateway for VRF System.

The aim of this integration is to monitor and control your Fujitsu VRF air conditioning system, remotely, from your Control Center using any commercial SCADA or monitoring software that includes a BACnet/IP driver. To do it so, the BACnet Gateway for VRF System allows BACnet/IP communication, acting as a server, allowing polling or subscription requests (COV).

The BACnet Gateway for VRF System makes available the Fujitsu air conditioning system indoor and outdoor units and its abstraction of Fujitsu air conditioning system properties and functionalities as fixed and independent BACnet Objects.

Simple configuration is needed: just select the appropriate communication parameters.

Up to 128 indoor units supported.

This document assumes that the user is familiar with BACnet and Fujitsu technologies and their technical terms.

Note: The 2 types of BACnet Gateway, UTY-ABGX and UTY-VBGX may not coexist within a VRF system.

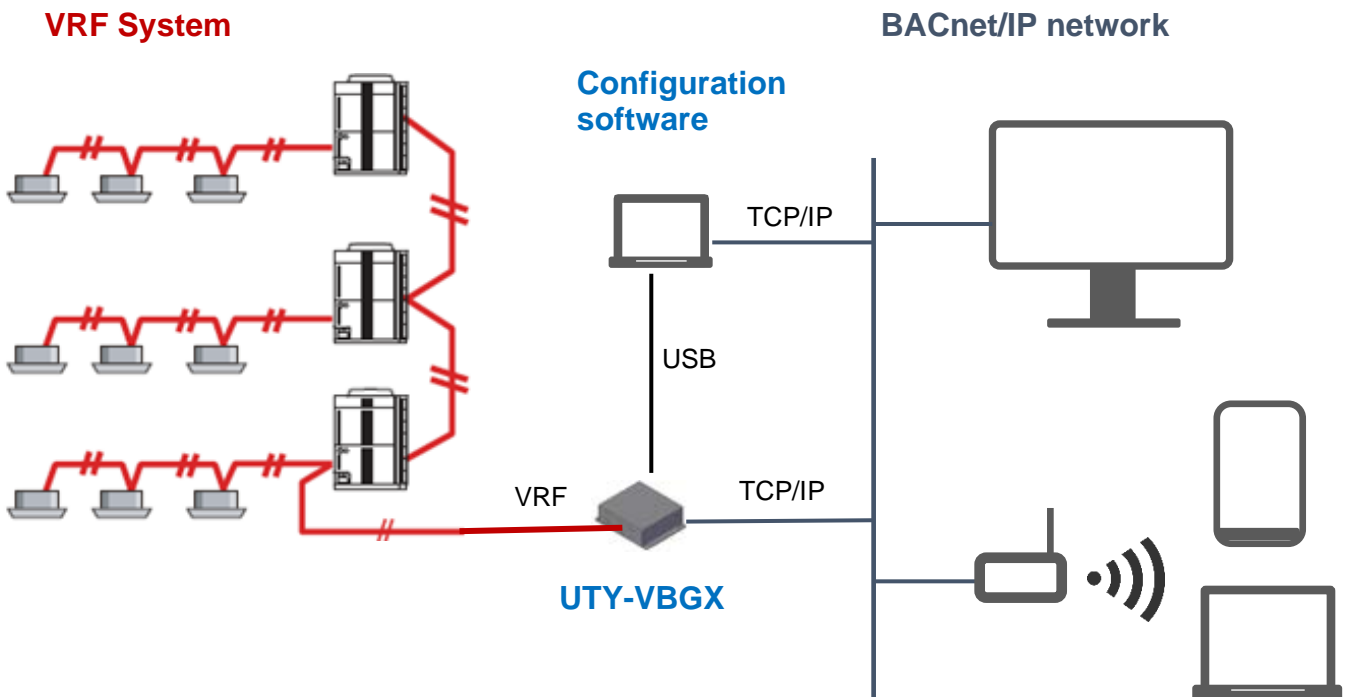

1.2 Functionality

The gateway continuously polls (reads) the VRF network for all configured signals and keeps the updated status of all of them in its memory, ready to be served when requested from the BACnet side.

The role of the gateway consists in associate the elements of the FGL indoor and outdoor units with BACnet objects.

The control of the indoor and outdoor units through the FGL bus is permitted, so commands toward the FGL indoor and outdoor units are allowed.

Each indoor and outdoor unit is offered in a set of BACnet objects.

Element	Object supported
Gateway	<ul style="list-style-type: none"> • Status • Command • Error
Indoor Unit	<ul style="list-style-type: none"> • Status • Command • Error
Outdoor Unit	<ul style="list-style-type: none"> • Status • Command • Error

1.3 Capacity of UTY-VBGX

Element	Max.	Notes
Number of indoor units	128	Number of indoor units that can be controlled through UTY-VBGX
Number of outdoor units	100	Number of outdoor units that can be controlled through UTY-VBGX
Number of VRF systems	1	Number of independent VRF systems that can be controlled through UTY-VBGX
Number of Refrigerant systems	32	Number of refrigerant systems that can be controlled through UTY-VBGX
Number of Objects	5000	Number of FGL control and status objects available into UTY-VBGX.

The number of *Indoor Units* and *Outdoor Units* may vary on each project. These parameters can be configured through Configuration Tool (See section 8).

2 Protocol Implementation Conformance Statement

BACnet Protocol Implementation Conformance Statement (PICS)

Date: 2021-2-4

Vendor Name: Fujitsu General Limited

Product Name: BACnet Gateway for VRF System

Product Model Number: UTY-VBGX

Application Software Version: 1.1.3.0

Firmware Revision: 14.1.2.0

BACnet Protocol Revision: 14

Note. Application Software Version and Firmware Revision may change without affecting the description in this statement.

Product Description:

BACnet Gateway for VRF System

2.1 BACnet Standardized Device Profile (Annex L):

- BACnet Operator Workstation (B-OWS)
- BACnet Building Controller (B-BC)
- BACnet Advanced Application Controller (B-AAC)
- BACnet Application Specific Controller (B-ASC)
- BACnet Smart Sensor (B-SS)
- BACnet Smart Actuator (B-SA)

Additional BACnet Interoperability Building Blocks Supported (Annex K):
Reference of BIBBs List

2.2 Segmentation Capability:

Segmented request supported No Yes Window Size 16 .
 Segmented responses supported No Yes Window Size 16 .

2.3 Data Link Layer Options:

- BACnet IP, (Annex J)
- BACnet IP, (Annex J), Foreign Device
- ISO 8802-3, Ethernet (Clause 7)
- ANSI/ATA 878.1, 2.5 Mb. ARCNET (Clause 8)
- ANSI/ATA 878.1, RS-485 ARCNET (Clause 8), baud rate(s) _____
- MS/TP master (Clause 9), baud rate(s): _____
- MS/TP slave (Clause 9), baud rate(s): _____
- Point-To-Point, EIA 232 (Clause 10), baud rate(s): _____
- Point-To-Point, modem, (Clause 10), baud rate(s): _____
- LonTalk, (Clause 11), medium: _____
- Other: _____

2.4 Device Address Binding:

Is static device binding supported? (This is currently necessary for two-way communication with MS/TP slaves and certain other devices.) Yes No

2.5 Networking Options:

- Router, Clause 6 - List all routing configurations, e.g., ARCNET-Ethernet, Ethernet-MS/TP, etc.
- Annex H, BACnet Tunneling Router over IP
- BACnet/IP Broadcast Management Device (BBMD)
Does the BBMD support registrations by Foreign Devices? Yes No

2.6 Character Sets Supported

Indicating support for multiple character sets does not imply that they can all be supported simultaneously.

- ISO 10646 (UTF-8)
- IBM™/Microsoft™ DBCS
- ISO 8859-1
- ISO 10646 (UCS-2)
- ISO 10646 (UCS-4)
- JIS X 0208

2.7 Gateway

If this product is a communication gateway, describe the types of non-BACnet equipment/network(s) that the gateway supports:

Fujitsu VRF Air Conditioning Network.

3 BACnet Interoperability Building Blocks Supported (BIBBs)

3.1 Data Sharing BIBBs

BIBB Type		Active	BACnet Service	Initiate	Execute
DS-RP-A	Data Sharing-ReadProperty-A	<input type="checkbox"/>	ReadProperty	<input checked="" type="checkbox"/>	<input type="checkbox"/>
DS-RP-B	Data Sharing-ReadProperty-B	<input checked="" type="checkbox"/>	ReadProperty	<input type="checkbox"/>	<input checked="" type="checkbox"/>
DS-RPM-A	Data Sharing-ReadPropertyMultiple-A	<input type="checkbox"/>	ReadPropertyMultiple	<input checked="" type="checkbox"/>	<input type="checkbox"/>
DS-RPM-B	Data Sharing-ReadPropertyMultiple-B	<input checked="" type="checkbox"/>	ReadPropertyMultiple	<input type="checkbox"/>	<input checked="" type="checkbox"/>
DS-WP-A	Data Sharing-WriteProperty-A	<input type="checkbox"/>	WriteProperty	<input checked="" type="checkbox"/>	<input type="checkbox"/>
DS-WP-B	Data Sharing-WriteProperty-B	<input checked="" type="checkbox"/>	WriteProperty	<input type="checkbox"/>	<input checked="" type="checkbox"/>
DS-WPM-A	Data Sharing-WritePropertyMultiple-A	<input type="checkbox"/>	WritePropertyMultiple	<input checked="" type="checkbox"/>	<input type="checkbox"/>
DS-WPM-B	Data Sharing-WritePropertyMultiple-B	<input checked="" type="checkbox"/>	WritePropertyMultiple	<input type="checkbox"/>	<input checked="" type="checkbox"/>
DS-COV-A	Data Sharing-COV-A	<input type="checkbox"/>	SubscribeCOV	<input checked="" type="checkbox"/>	<input type="checkbox"/>
			ConfirmedCOVNotification	<input type="checkbox"/>	<input checked="" type="checkbox"/>
			UnconfirmedCOVNotification	<input type="checkbox"/>	<input checked="" type="checkbox"/>
DS-COV-B	Data Sharing-COV-B	<input checked="" type="checkbox"/>	SubscribeCOV	<input type="checkbox"/>	<input checked="" type="checkbox"/>
			ConfirmedCOVNotification	<input checked="" type="checkbox"/>	<input type="checkbox"/>
			UnconfirmedCOVNotification	<input checked="" type="checkbox"/>	<input type="checkbox"/>
DS-COVP-A	Data Sharing-COVP-A	<input type="checkbox"/>	SubscribeCOVProperty	<input checked="" type="checkbox"/>	<input type="checkbox"/>
			ConfirmedCOVNotification	<input type="checkbox"/>	<input checked="" type="checkbox"/>
			UnconfirmedCOVNotification	<input type="checkbox"/>	<input checked="" type="checkbox"/>
DS-COVP-B	Data Sharing-COVP-B	<input type="checkbox"/>	SubscribeCOVProperty	<input type="checkbox"/>	<input checked="" type="checkbox"/>
			ConfirmedCOVNotification	<input checked="" type="checkbox"/>	<input type="checkbox"/>
			UnconfirmedCOVNotification	<input checked="" type="checkbox"/>	<input type="checkbox"/>
DS-COVU-A	Data Sharing-COV-Unsubscribed-A	<input type="checkbox"/>	UnconfirmedCOVNotification	<input type="checkbox"/>	<input checked="" type="checkbox"/>
DS-COVU-B	Data Sharing-COV- Unsubscribed -B	<input type="checkbox"/>	UnconfirmedCOVNotification	<input checked="" type="checkbox"/>	<input type="checkbox"/>
DS-V-A	Data Sharing-View-A	<input type="checkbox"/>	ReadProperty	<input checked="" type="checkbox"/>	<input type="checkbox"/>
DS-AV-A	Data Sharing-Advanced View-A	<input type="checkbox"/>	ReadProperty	<input checked="" type="checkbox"/>	<input type="checkbox"/>
DS-M-A	Data Sharing-Modify-A	<input type="checkbox"/>	WriteProperty	<input checked="" type="checkbox"/>	<input type="checkbox"/>
DS-AM-A	Data Sharing-Advanced Modify-A	<input type="checkbox"/>	WriteProperty	<input checked="" type="checkbox"/>	<input type="checkbox"/>
DS-WG-A	Data Sharing-WriteGroup-A	<input type="checkbox"/>	WriteGroup	<input checked="" type="checkbox"/>	<input type="checkbox"/>
DS-WG-I-B	Data Sharing-WriteGroup-Internal-B	<input type="checkbox"/>	WriteGroup	<input type="checkbox"/>	<input checked="" type="checkbox"/>
DS-WG-E-B	Data Sharing-WriteGroup-External-B	<input type="checkbox"/>	WriteGroup	<input type="checkbox"/>	<input checked="" type="checkbox"/>
			WriteProperty	<input checked="" type="checkbox"/>	<input type="checkbox"/>

3.2 Alarm and Event Management BIBBs

BIBB Type		Active	BACnet Service	Initiate	Execute
AE-N-A	Alarm and Event-Notification-A	<input type="checkbox"/>	ConfirmedEventNotification	<input type="checkbox"/>	<input checked="" type="checkbox"/>
			UnconfirmedEventNotification	<input type="checkbox"/>	<input checked="" type="checkbox"/>
AE-N-I-B	Alarm and Event-Notification Internal-B	<input checked="" type="checkbox"/>	ConfirmedEventNotification	<input checked="" type="checkbox"/>	<input type="checkbox"/>
			UnconfirmedEventNotification	<input checked="" type="checkbox"/>	<input type="checkbox"/>
AE-N-E-B	Alarm and Event-Notification External-B	<input type="checkbox"/>	ConfirmedEventNotification	<input checked="" type="checkbox"/>	<input type="checkbox"/>
			UnconfirmedEventNotification	<input checked="" type="checkbox"/>	<input type="checkbox"/>
AE-ACK-A	Alarm and Event-ACK-A	<input type="checkbox"/>	AcknowledgeAlarm	<input checked="" type="checkbox"/>	<input type="checkbox"/>
AE-ACK-B	Alarm and Event-ACK-B	<input checked="" type="checkbox"/>	AcknowledgeAlarm	<input type="checkbox"/>	<input checked="" type="checkbox"/>
AE-ASUM-A	Alarm and Event-Alarm Summary-A	<input type="checkbox"/>	GetAlarmSummary	<input checked="" type="checkbox"/>	<input type="checkbox"/>
AE-ASUM-B	Alarm and Event-Alarm Summary-B	<input checked="" type="checkbox"/>	GetAlarmSummary	<input type="checkbox"/>	<input checked="" type="checkbox"/>
AE-ESUM-A	Alarm and Event-Enrollment Summary-A	<input type="checkbox"/>	GetEnrollmentSummary	<input checked="" type="checkbox"/>	<input type="checkbox"/>
AE-ESUM-B	Alarm and Event-Enrollment Summary-B	<input type="checkbox"/>	GetEnrollmentSummary	<input type="checkbox"/>	<input checked="" type="checkbox"/>
AE-INFO-A	Alarm and Event-Information-A	<input type="checkbox"/>	GetEventInformation	<input checked="" type="checkbox"/>	<input type="checkbox"/>
AE-INFO-B	Alarm and Event-Information-B	<input checked="" type="checkbox"/>	GetEventInformation	<input type="checkbox"/>	<input checked="" type="checkbox"/>
AE-LS-A	Alarm and Event-LifeSafety-A	<input type="checkbox"/>	LifeSafetyOperation	<input checked="" type="checkbox"/>	<input type="checkbox"/>
			ConfirmedEventNotification	<input type="checkbox"/>	<input checked="" type="checkbox"/>
			UnconfirmedEventNotification	<input type="checkbox"/>	<input checked="" type="checkbox"/>
			AcknowledgeAlarm	<input checked="" type="checkbox"/>	<input type="checkbox"/>

AE-LS-B	Alarm and Event-LifeSafety-B	<input type="checkbox"/>	LifeSafetyOperation	<input type="checkbox"/>	<input checked="" type="checkbox"/>
			ConfirmedEventNotification	<input checked="" type="checkbox"/>	<input type="checkbox"/>
			UnconfirmedEventNotification	<input checked="" type="checkbox"/>	<input type="checkbox"/>
AE-VN-A	Alarm and Event Management-View Notifications-A	<input type="checkbox"/>	ConfirmedEventNotification	<input type="checkbox"/>	<input checked="" type="checkbox"/>
			UnconfirmedEventNotification	<input type="checkbox"/>	<input checked="" type="checkbox"/>
AE-AVN-A	Alarm and Event Management-Advanced View Notifications-A	<input type="checkbox"/>	ConfirmedEventNotification	<input type="checkbox"/>	<input checked="" type="checkbox"/>
			UnconfirmedEventNotification	<input type="checkbox"/>	<input checked="" type="checkbox"/>
AE-VM-A	Alarm and Event Management-View and Modify-A	<input type="checkbox"/>	ReadProperty	<input checked="" type="checkbox"/>	<input type="checkbox"/>
			WriteProperty	<input checked="" type="checkbox"/>	<input type="checkbox"/>
AE-AVM-A	Alarm and Event Management-Advanced View and Modify-A	<input type="checkbox"/>	CreateObject	<input checked="" type="checkbox"/>	<input type="checkbox"/>
			DeleteObject	<input checked="" type="checkbox"/>	<input type="checkbox"/>
			ReadProperty	<input checked="" type="checkbox"/>	<input type="checkbox"/>
			WriteProperty	<input checked="" type="checkbox"/>	<input type="checkbox"/>
AE-AS-A	Alarm and Event Management-Alarm Summary View-A	<input type="checkbox"/>	GetEventInformation	<input checked="" type="checkbox"/>	<input type="checkbox"/>
			GetEnrollmentSummary	<input checked="" type="checkbox"/>	<input type="checkbox"/>
			GetAlarmSummary	<input checked="" type="checkbox"/>	<input type="checkbox"/>
AE-ELV-A	Alarm and Event Management-Event Log View-A	<input type="checkbox"/>	ReadRange	<input checked="" type="checkbox"/>	<input type="checkbox"/>
AE-ELVM-A	Alarm and Event Management-Event Log View and Modify-A	<input type="checkbox"/>	ReadRange	<input checked="" type="checkbox"/>	<input type="checkbox"/>
			ReadProperty	<input checked="" type="checkbox"/>	<input type="checkbox"/>
			WriteProperty	<input checked="" type="checkbox"/>	<input type="checkbox"/>
AE-EL-I-B	Alarm and Event Management-Event Log-Internal-B	<input type="checkbox"/>	ReadRange	<input type="checkbox"/>	<input checked="" type="checkbox"/>
AE-EL-E-B	Alarm and Event Management-Event Log-External-B	<input type="checkbox"/>	ReadRange	<input type="checkbox"/>	<input checked="" type="checkbox"/>
			ConfirmedEventNotification	<input type="checkbox"/>	<input checked="" type="checkbox"/>
			UnconfirmedEventNotification	<input type="checkbox"/>	<input checked="" type="checkbox"/>
AE-NF-B	Alarm and Event Management-Notification Forwarder-B	<input type="checkbox"/>	ConfirmedEventNotification	<input checked="" type="checkbox"/>	<input checked="" type="checkbox"/>
			UnconfirmedEventNotification	<input checked="" type="checkbox"/>	<input checked="" type="checkbox"/>
			AddListElement	<input type="checkbox"/>	<input checked="" type="checkbox"/>
			RemoveListElement	<input type="checkbox"/>	<input checked="" type="checkbox"/>
AE-NF-I-B	Alarm and Event Management-Notification Forwarder-Internal-B	<input type="checkbox"/>	ConfirmedEventNotification	<input checked="" type="checkbox"/>	<input type="checkbox"/>
			UnconfirmedEventNotification	<input checked="" type="checkbox"/>	<input type="checkbox"/>
			AddListElement	<input type="checkbox"/>	<input checked="" type="checkbox"/>
			RemoveListElement	<input type="checkbox"/>	<input checked="" type="checkbox"/>

3.3 Scheduling BIBBs

BIBB Type		Active	BACnet Service	Initiate	Execute
SCHED-I-B	Scheduling-Internal-B (shall support DS-RP-B and DS-WP-B) (shall also support either DM-TS-B or DS-UTC-B)	<input type="checkbox"/>			
SCHED-E-B	Scheduling-External-B (shall support SCHED-I-B and DS-WP-A)	<input type="checkbox"/>			
SCHED-R-B	Scheduling-Readonly-B (support DS-RP-B and either DM-TS-B or DM-UTC-B)	<input type="checkbox"/>			
SCHED-AVM-A	Scheduling-Advanced View and Modify-A	<input type="checkbox"/>	CreateObject	<input checked="" type="checkbox"/>	<input type="checkbox"/>
			DeleteObject	<input checked="" type="checkbox"/>	<input type="checkbox"/>
			ReadProperty	<input checked="" type="checkbox"/>	<input type="checkbox"/>
			WriteProperty	<input checked="" type="checkbox"/>	<input type="checkbox"/>
SCHED-VM-A	Scheduling-View and Modify-A	<input type="checkbox"/>	ReadProperty	<input checked="" type="checkbox"/>	<input type="checkbox"/>
			WriteProperty	<input checked="" type="checkbox"/>	<input type="checkbox"/>
SCHED-WS-A	Scheduling-Weekly Schedule-A	<input type="checkbox"/>	ReadProperty	<input checked="" type="checkbox"/>	<input type="checkbox"/>
			WriteProperty	<input checked="" type="checkbox"/>	<input type="checkbox"/>
SCHED-WS-I-B	Scheduling-Weekly Schedule Internal-B	<input type="checkbox"/>	ReadProperty	<input type="checkbox"/>	<input checked="" type="checkbox"/>
			WriteProperty	<input type="checkbox"/>	<input checked="" type="checkbox"/>
			TimeSynchronization	<input type="checkbox"/>	<input checked="" type="checkbox"/>
			UTCTimeSynchronization	<input type="checkbox"/>	<input checked="" type="checkbox"/>

3.4 Trending BIBBs

BIBB Type		Active	BACnet Service	Initiate	Execute
T-VMT-I-B	Trending - Viewing and Modifying Trends Internal-B	<input type="checkbox"/>	ReadRange	<input type="checkbox"/>	<input checked="" type="checkbox"/>
T-VMT-E-B	Trending - Viewing and Modifying Trends External-B	<input type="checkbox"/>	ReadRange	<input type="checkbox"/>	<input checked="" type="checkbox"/>
T-ATR-A	Trending - Automated Trend Retrieval-A	<input type="checkbox"/>	ConfirmedEventNotification	<input type="checkbox"/>	<input checked="" type="checkbox"/>
			UnconfirmedEventNotification	<input type="checkbox"/>	<input checked="" type="checkbox"/>
			ReadRange	<input checked="" type="checkbox"/>	<input type="checkbox"/>
T-ATR-B	Trending - Automated Trend Retrieval-B	<input type="checkbox"/>	ConfirmedEventNotification	<input checked="" type="checkbox"/>	<input type="checkbox"/>
			UnconfirmedEventNotification	<input checked="" type="checkbox"/>	<input type="checkbox"/>
			ReadRange	<input type="checkbox"/>	<input checked="" type="checkbox"/>
T-VMMV-I-B	Trending - Viewing and Modifying Multiple Values Internal-B	<input type="checkbox"/>	ReadRange	<input type="checkbox"/>	<input checked="" type="checkbox"/>
T-VMMV-E-B	Trending - Viewing and Modifying Multiple Values External-B	<input type="checkbox"/>	ReadRange	<input type="checkbox"/>	<input checked="" type="checkbox"/>
			ReadPropertyMultiple	<input checked="" type="checkbox"/>	<input type="checkbox"/>
T-AMVR-A	Trending - Automated Multiple Value Retrieval-A	<input type="checkbox"/>	ConfirmedEventNotification	<input type="checkbox"/>	<input checked="" type="checkbox"/>
			UnconfirmedEventNotification	<input type="checkbox"/>	<input checked="" type="checkbox"/>
			ReadRange	<input checked="" type="checkbox"/>	<input type="checkbox"/>
T-AMRV-B	Trending - Automated Multiple Value Retrieval-B	<input type="checkbox"/>	ConfirmedEventNotification	<input checked="" type="checkbox"/>	<input type="checkbox"/>
			UnconfirmedEventNotification	<input checked="" type="checkbox"/>	<input type="checkbox"/>
			ReadRange	<input type="checkbox"/>	<input checked="" type="checkbox"/>
T-V-A	Trending - View-A	<input type="checkbox"/>	ReadRange	<input checked="" type="checkbox"/>	<input type="checkbox"/>
T-AVM-A	Trending - Advanced View and Modify-A	<input type="checkbox"/>	CreateObject	<input checked="" type="checkbox"/>	<input type="checkbox"/>
			DeleteObject	<input checked="" type="checkbox"/>	<input type="checkbox"/>
			ReadProperty	<input checked="" type="checkbox"/>	<input type="checkbox"/>
			ReadRange	<input checked="" type="checkbox"/>	<input type="checkbox"/>
			WriteProperty	<input checked="" type="checkbox"/>	<input type="checkbox"/>
T-A-A	Trending - Archival-A	<input type="checkbox"/>	T-ATR-A		
			T-AMRV-A		

3.5 Device and Network Management BIBBs

BIBB Type		Active	BACnet Service	Initiate	Execute
DM-DDB-A	Device Management - Dynamic Device Binding-A	<input checked="" type="checkbox"/>	Who-Is	<input checked="" type="checkbox"/>	<input type="checkbox"/>
			I-Am	<input type="checkbox"/>	<input checked="" type="checkbox"/>
DM-DDB-B	Device Management - Dynamic Device Binding-B	<input checked="" type="checkbox"/>	Who-Is	<input type="checkbox"/>	<input checked="" type="checkbox"/>
			I-Am	<input checked="" type="checkbox"/>	<input type="checkbox"/>
DM-DOB-A	Device Management - Dynamic Object Binding-A	<input type="checkbox"/>	Who-Has	<input checked="" type="checkbox"/>	<input type="checkbox"/>
			I-Have	<input type="checkbox"/>	<input checked="" type="checkbox"/>
DM-DOB-B	Device Management - Dynamic Object Binding-B	<input checked="" type="checkbox"/>	Who-Has	<input type="checkbox"/>	<input checked="" type="checkbox"/>
			I-Have	<input checked="" type="checkbox"/>	<input type="checkbox"/>
DM-DCC-A	Device Management - DeviceCommunicationControl-A	<input type="checkbox"/>	DeviceCommunicationControl	<input checked="" type="checkbox"/>	<input type="checkbox"/>
DM-DCC-B	Device Management - DeviceCommunicationControl-B	<input checked="" type="checkbox"/>	DeviceCommunicationControl	<input type="checkbox"/>	<input checked="" type="checkbox"/>
DM-TM-A	Device Management - Text Message-A	<input type="checkbox"/>	ConfirmedTextMessage	<input checked="" type="checkbox"/>	<input type="checkbox"/>
			UnconfirmedTextMessage	<input checked="" type="checkbox"/>	<input type="checkbox"/>
DM-TM-B	Device Management - Text Message-B	<input type="checkbox"/>	ConfirmedTextMessage	<input type="checkbox"/>	<input checked="" type="checkbox"/>
			UnconfirmedTextMessage	<input type="checkbox"/>	<input checked="" type="checkbox"/>
DM-TS-A	Device Management - TimeSynchronization-A	<input type="checkbox"/>	TimeSynchronization	<input checked="" type="checkbox"/>	<input type="checkbox"/>
DM-TS-B	Device Management - TimeSynchronization-B	<input checked="" type="checkbox"/>	TimeSynchronization	<input type="checkbox"/>	<input checked="" type="checkbox"/>
DM-UTC-A	Device Management - UTCTimeSynchronization-A	<input type="checkbox"/>	UTCTimeSynchronization	<input checked="" type="checkbox"/>	<input type="checkbox"/>

DM-UTC-B	Device Management - UTCTimeSynchronization-B	<input type="checkbox"/>	UTCTimeSynchronization	<input type="checkbox"/>	<input checked="" type="checkbox"/>
DM-RD-A	Device Management - ReinitializeDevice-A	<input type="checkbox"/>	ReinitializeDevice	<input checked="" type="checkbox"/>	<input type="checkbox"/>
DM-RD-B	Device Management - ReinitializeDevice-B	<input checked="" type="checkbox"/>	ReinitializeDevice	<input type="checkbox"/>	<input checked="" type="checkbox"/>
DM-BR-A	Device Management - Backup and Restore-A	<input type="checkbox"/>	AtomicReadFile	<input checked="" type="checkbox"/>	<input type="checkbox"/>
			AtomicWriteFile	<input checked="" type="checkbox"/>	<input type="checkbox"/>
			CreateObject	<input checked="" type="checkbox"/>	<input type="checkbox"/>
			ReinitializeDevice	<input checked="" type="checkbox"/>	<input type="checkbox"/>
DM-BR-B	Device Management - Backup and Restore-B	<input type="checkbox"/>	AtomicReadFile	<input type="checkbox"/>	<input checked="" type="checkbox"/>
			AtomicWriteFile	<input type="checkbox"/>	<input checked="" type="checkbox"/>
			ReinitializeDevice	<input type="checkbox"/>	<input checked="" type="checkbox"/>
DM-R-A	Device Management - Restart-A	<input type="checkbox"/>	UnconfirmedCOVNotification	<input type="checkbox"/>	<input checked="" type="checkbox"/>
DM-R-B	Device Management - Restart-B		UnconfirmedCOVNotification	<input checked="" type="checkbox"/>	<input type="checkbox"/>
DM-LM-A	Device Management - List Manipulation-A	<input type="checkbox"/>	AddListElement	<input checked="" type="checkbox"/>	<input type="checkbox"/>
			RemoveListElement	<input checked="" type="checkbox"/>	<input type="checkbox"/>
DM-LM-B	Device Management - List Manipulation-B	<input type="checkbox"/>	AddListElement	<input type="checkbox"/>	<input checked="" type="checkbox"/>
			RemoveListElement	<input type="checkbox"/>	<input checked="" type="checkbox"/>
DM-OCD-A	Device Management - Object Creation and Deletion-A	<input type="checkbox"/>	CreateObject	<input checked="" type="checkbox"/>	<input type="checkbox"/>
			DeleteObject	<input checked="" type="checkbox"/>	<input type="checkbox"/>
DM-OCD-B	Device Management - Object Creation and Deletion-B	<input type="checkbox"/>	CreateObject	<input type="checkbox"/>	<input checked="" type="checkbox"/>
			DeleteObject	<input type="checkbox"/>	<input checked="" type="checkbox"/>
DM-VT-A	Device Management - Virtual Terminal-A	<input type="checkbox"/>	VT-Open	<input checked="" type="checkbox"/>	<input type="checkbox"/>
			VT-Close	<input checked="" type="checkbox"/>	<input checked="" type="checkbox"/>
			VT-Data	<input checked="" type="checkbox"/>	<input checked="" type="checkbox"/>
DM-VT-B	Device Management - Virtual Terminal-B	<input type="checkbox"/>	VT-Open	<input type="checkbox"/>	<input checked="" type="checkbox"/>
			VT-Close	<input checked="" type="checkbox"/>	<input checked="" type="checkbox"/>
			VT-Data	<input checked="" type="checkbox"/>	<input checked="" type="checkbox"/>
NM-CE-A	Network Management - Connection Establishment-A	<input type="checkbox"/>	Establish-Connection-To-Network	<input checked="" type="checkbox"/>	<input type="checkbox"/>
			Disconnect-Connection-To-Network	<input checked="" type="checkbox"/>	<input type="checkbox"/>
NM-CE-B	Network Management - Connection Establishment-B	<input type="checkbox"/>	Establish-Connection-To-Network	<input type="checkbox"/>	<input checked="" type="checkbox"/>
			Disconnect-Connection-To-Network	<input type="checkbox"/>	<input checked="" type="checkbox"/>
NM-RC-A	Network Management - Router Configuration-A	<input type="checkbox"/>	Who-Is-Router-To-Network	<input checked="" type="checkbox"/>	<input type="checkbox"/>
			I-Am-Router-To-Network	<input type="checkbox"/>	<input checked="" type="checkbox"/>
			I-Could-Be-Router-To-Network	<input type="checkbox"/>	<input checked="" type="checkbox"/>
			Initialize-Routing-Table	<input checked="" type="checkbox"/>	<input type="checkbox"/>
NM-RC-B	Network Management - Router Configuration-B	<input type="checkbox"/>	Initialize-Routing-Table-Ack	<input type="checkbox"/>	<input checked="" type="checkbox"/>
			Who-Is-Router-To-Network	<input checked="" type="checkbox"/>	<input checked="" type="checkbox"/>
			I-Am-Router-To-Network	<input checked="" type="checkbox"/>	<input checked="" type="checkbox"/>
			Initialize-Routing-Table	<input type="checkbox"/>	<input checked="" type="checkbox"/>
DM-ANM-A	Device Management-Automatic Network Mapping-A	<input type="checkbox"/>	DM-DDB-B		
			DM-DDB-A		
DM-ADM-A	Device Management-Automatic Device Mapping-A	<input type="checkbox"/>	DS-RP-A		
			DM-ADM-A		
DM-ATS-A	Device Management-Automatic Time Synchronization-A	<input type="checkbox"/>	TimeSynchronization	<input checked="" type="checkbox"/>	<input type="checkbox"/>
			UTCTimeSynchronization	<input checked="" type="checkbox"/>	<input type="checkbox"/>
			DM-ATS-A		
DM-MTS-A	Device Management-Manual Time Synchronization-A	<input type="checkbox"/>	TimeSynchronization	<input checked="" type="checkbox"/>	<input type="checkbox"/>
			UTCTimeSynchronization	<input checked="" type="checkbox"/>	<input type="checkbox"/>

3.6 Network Security BIBBs

BIBB Type		Active	BACnet Service	Initiate	Execute
NS-SD	Network Security-Secure Device	<input type="checkbox"/>	Challenge-Request	<input type="checkbox"/>	<input checked="" type="checkbox"/>
			Security-Payload	<input checked="" type="checkbox"/>	<input checked="" type="checkbox"/>
			Security-Response	<input checked="" type="checkbox"/>	<input checked="" type="checkbox"/>
			Request-Key-Update	<input checked="" type="checkbox"/>	<input type="checkbox"/>
			Update-Key-Set	<input type="checkbox"/>	<input checked="" type="checkbox"/>
			Update-Distribution-Key	<input type="checkbox"/>	<input checked="" type="checkbox"/>
			What-Is-Network-Number	<input checked="" type="checkbox"/>	<input checked="" type="checkbox"/>
			Network-Number-Is	<input checked="" type="checkbox"/>	<input checked="" type="checkbox"/>
NS-ED	Network Security-Encrypted Device	<input type="checkbox"/>	NS-SD		
NS-MAD	Network Security-Multi-Application Device	<input type="checkbox"/>	NS-ED		
NS-DMK-A	Network Security-Device Master Key-A	<input type="checkbox"/>	Request-Master-Key	<input type="checkbox"/>	<input checked="" type="checkbox"/>
			Set-Master-Key	<input checked="" type="checkbox"/>	<input type="checkbox"/>
NS-DMK-B	Network Security-Device Master Key-B	<input type="checkbox"/>	Request-Master-Key	<input checked="" type="checkbox"/>	<input type="checkbox"/>
			Set-Master-Key	<input type="checkbox"/>	<input checked="" type="checkbox"/>
NS-KS	Network Security-Key Server	<input type="checkbox"/>	Request-Key-Update	<input type="checkbox"/>	<input checked="" type="checkbox"/>
			Update-Key-Set	<input checked="" type="checkbox"/>	<input type="checkbox"/>
			Update-Distribution-Key	<input checked="" type="checkbox"/>	<input type="checkbox"/>
			Request-Master-Key	<input type="checkbox"/>	<input checked="" type="checkbox"/>
			Set-Master-Key	<input checked="" type="checkbox"/>	<input type="checkbox"/>
			NS-SD		
			NS-DMK-A		
NS-TKS	Network Security-Temporary Key Server	<input type="checkbox"/>	Request-Key-Update	<input type="checkbox"/>	<input checked="" type="checkbox"/>
			Update-Key-Set	<input checked="" type="checkbox"/>	<input type="checkbox"/>
			Update-Distribution-Key	<input checked="" type="checkbox"/>	<input type="checkbox"/>
			Request-Master-Key	<input type="checkbox"/>	<input checked="" type="checkbox"/>
			Set-Master-Key	<input checked="" type="checkbox"/>	<input type="checkbox"/>
			NS-SD		
			NS-DMK-A		
NS-SR	Network Security-Secure Router	<input type="checkbox"/>	NS-SD		
			NS-ED		
NS-SP	Network Security-Security Proxy	<input type="checkbox"/>	NS-SR		

4 Service Types

Service type	Service name	Supported	Remarks
Alarm and Event Services	AcknowledgeAlarm	<input checked="" type="checkbox"/>	
	ConfirmedCOVNotification	<input type="checkbox"/>	
	ConfirmedEventNotification	<input type="checkbox"/>	
	GetAlarmSummary	<input checked="" type="checkbox"/>	
	GetEnrollmentSummary	<input type="checkbox"/>	
	SubscribeCOV	<input checked="" type="checkbox"/>	
File Access Services	AtomicReadFile	<input type="checkbox"/>	
	AtomicWriteFile	<input type="checkbox"/>	
Object Access Services	AddListElement	<input type="checkbox"/>	
	RemoveListElement	<input type="checkbox"/>	
	CreateObject	<input type="checkbox"/>	
	DeleteObject	<input type="checkbox"/>	
	ReadProperty	<input checked="" type="checkbox"/>	
	ReadPropertyConditional	<input type="checkbox"/>	
	ReadPropertyMultiple	<input checked="" type="checkbox"/>	
	ReadRange	<input type="checkbox"/>	
	WriteGroup	<input type="checkbox"/>	
	WriteProperty	<input checked="" type="checkbox"/>	
	WritePropertyMultiple	<input checked="" type="checkbox"/>	
Remote Device Management Services	DeviceCommunicationControl	<input checked="" type="checkbox"/>	
	ConfirmedPrivateTransfer	<input type="checkbox"/>	
	ConfirmedTextMessage	<input type="checkbox"/>	
	ReinitializeDevice	<input checked="" type="checkbox"/>	
Virtual Terminal Services	VtOpen	<input type="checkbox"/>	
	VtClose	<input type="checkbox"/>	
	VtData	<input type="checkbox"/>	
Security Services	Authenticate	<input type="checkbox"/>	
	RequestKey	<input type="checkbox"/>	
Unconfirmed Services	I-Am	<input checked="" type="checkbox"/>	
	I-Have	<input type="checkbox"/>	
	UnconfirmedCOVNotification	<input type="checkbox"/>	
	UnconfirmedEventNotification	<input type="checkbox"/>	
	UnconfirmedPrivateTransfer	<input type="checkbox"/>	
	UnconfirmedTextMessage	<input type="checkbox"/>	
	TimeSynchronization	<input checked="" type="checkbox"/>	
	UtcTimeSynchronization	<input type="checkbox"/>	
	Who-Has	<input checked="" type="checkbox"/>	
	Who-Is	<input checked="" type="checkbox"/>	
	LifeSafetyOperation	<input type="checkbox"/>	
	SubscribeCOVProperty	<input type="checkbox"/>	
	GetEventInformation	<input checked="" type="checkbox"/>	

5 Objects

5.1 Supported Object Types

The objects supported are shown in the table below.

Object Type	ID	Supported	Management Point
Analog-Input	0	<input checked="" type="checkbox"/>	IU_rr_uu_SetTemp_Status IU_rr_uu_SpaceTemp_Status IU_rr_uu_AutoTempLoLim_Status IU_rr_uu_AutoTempHiLim_Status IU_rr_uu_CoolTempLoLim_Status IU_rr_uu_CoolTempHiLim_Status IU_rr_uu_HeatTempLoLim_Status IU_rr_uu_HeatTempHiLim_Status
Analog-Output	1	<input checked="" type="checkbox"/>	Batch_SetTemp_Setting IU_rr_uu_SetTemp_Setting IU_rr_uu_AutoTempLoLim_Setting IU_rr_uu_AutoTempHiLim_Setting IU_rr_uu_CoolTempLoLim_Setting IU_rr_uu_CoolTempHiLim_Setting IU_rr_uu_HeatTempLoLim_Setting IU_rr_uu_HeatTempHiLim_Setting
Analog-Value	2	<input type="checkbox"/>	
Binary-Input	3	<input checked="" type="checkbox"/>	Gateway_ES_Status Gateway_Error_Status IU_rr_uu_Exists_Status IU_rr_uu_Operation_Status IU_rr_uu_ThermostatOFF_Status IU_rr_uu_FilterSign_Status IU_rr_uu_Emergency_Status IU_rr_uu_Error_Status IU_rr_uu_TempLimValid_Status OU_rr_uu_Error_Status OU_rr_uu_ForcedOff_Status
Binary-Output	4	<input checked="" type="checkbox"/>	Gateway_ES_Setting Batch_Operation_Setting IU_rr_uu_Operation_Setting IU_rr_uu_ThermostatOFF_Setting IU_rr_uu_Reset_Filter_Setting IU_rr_uu_TempLimValid_Setting OU_rr_uu_ForcedOff_Setting
Binary-Value	5	<input type="checkbox"/>	
Calendar	6	<input type="checkbox"/>	
Command	7	<input type="checkbox"/>	
Device	8	<input checked="" type="checkbox"/>	UTY-VBGX
Event-Enrollment	9	<input type="checkbox"/>	
File	10	<input type="checkbox"/>	
Group	11	<input type="checkbox"/>	
Loop	12	<input type="checkbox"/>	
Multistate-Input	13	<input checked="" type="checkbox"/>	Gateway_ErrorCode_Status IU_rr_uu_OperationMode_Status IU_rr_uu_FanSpeed_Status IU_rr_uu_AirFlowDirVT_Status IU_rr_uu_AirFlowDirHZ_Status IU_rr_uu_RC_Prohibit_Status IU_rr_uu_ErrorCode_Status IU_rr_uu_Managed_Mode_Status OU_rr_uu_ErrorCode_Status OU_rr_uu_CapacitySave_Status OU_rr_uu_LowNoiseOp_Status

Multistate-Output	14	<input checked="" type="checkbox"/>	Batch_OperationMode_Setting Batch_FanSpeed_Setting Batch_RC_Prohibition_Setting IU_rr_uu_OperationMode_Setting IU_rr_uu_FanSpeed_Setting IU_rr_uu_AirFlowDirVT_Setting IU_rr_uu_AirFlowDirHZ_Setting IU_rr_uu_RC_Prohibit_Setting OU_rr_uu_LowNoiseOp_Setting OU_rr_uu_CapacitySave_Setting
Notification-Class	15	<input checked="" type="checkbox"/>	NotificationClass_x
Program	16	<input type="checkbox"/>	
Schedule	17	<input type="checkbox"/>	
Averaging	18	<input type="checkbox"/>	
Multistate-Value	19	<input type="checkbox"/>	
Trend-Log	20	<input type="checkbox"/>	
Life-Safety-Point	21	<input type="checkbox"/>	
Life-Safety-Zone	22	<input type="checkbox"/>	
Accumulator	23	<input type="checkbox"/>	
Pulse-Converter	24	<input type="checkbox"/>	
Event-Log	25	<input type="checkbox"/>	
Global-Group	26	<input type="checkbox"/>	
Trend-Log-Multiple	27	<input type="checkbox"/>	
Load-Control	28	<input type="checkbox"/>	
Structured-View	29	<input type="checkbox"/>	
Access-Door	30	<input type="checkbox"/>	
Timer	31	<input type="checkbox"/>	
Access-Credential	32	<input type="checkbox"/>	
Access-Point	33	<input type="checkbox"/>	
Access-Rights	34	<input type="checkbox"/>	
Access-User	35	<input type="checkbox"/>	
Access-Zone	36	<input type="checkbox"/>	
Credential-Data-Input	37	<input type="checkbox"/>	
Network-Security	38	<input type="checkbox"/>	
Bitstring-Value	39	<input type="checkbox"/>	
CharacterString-Value	40	<input type="checkbox"/>	
Date-Pattern-Value	41	<input type="checkbox"/>	
Date-Value	42	<input type="checkbox"/>	
Datetime-Pattern-Value	43	<input type="checkbox"/>	
Datetime-Value	44	<input type="checkbox"/>	
Integer-Value	45	<input type="checkbox"/>	
Large-Analog-Value	46	<input type="checkbox"/>	
Octetstring-Value	47	<input type="checkbox"/>	
Positive-Integer-Value	48	<input type="checkbox"/>	
Time-Pattern-Value	49	<input type="checkbox"/>	
Time-Value	50	<input type="checkbox"/>	
Notification-Forwarder	51	<input type="checkbox"/>	
Alert-Enrollment	52	<input type="checkbox"/>	
Channel	53	<input type="checkbox"/>	
Lighting-Output	54	<input type="checkbox"/>	

5.2 Member objects

5.2.1 Type: Gateway

Object-name	Description	Object-type	Object-instance
UTY-VBGX	BACnet Gateway for VRF System	Device	144
Gateway_ES_Status	-	BI	0
Gateway_Error_Status	-	BI	1
Gateway_ES_Setting	-	BO	0
Gateway_ErrorCode_Status	-	MI	0

5.2.2 Type: Batch objects

Object-name	Object-type	Object-instance
Batch_SetTemp_Setting	AO	0
Batch_Operation_Setting	BO	1
Batch_OperationMode_Setting	MO	0
Batch_FanSpeed_Setting	MO	1
Batch_RC_Prohibition_Setting	MO	2

5.2.3 Type: Indoor Unit

Object-name	Object-type	Object-instance
IU_rr_uu_SetTemp_Status	AI	10rruu
IU_rr_uu_SpaceTemp_Status	AI	11rruu
IU_rr_uu_AutoTempLoLim_Status	AI	12rruu
IU_rr_uu_AutoTempHiLim_Status	AI	13rruu
IU_rr_uu_CoolTempLoLim_Status	AI	14rruu
IU_rr_uu_CoolTempHiLim_Status	AI	15rruu
IU_rr_uu_HeatTempLoLim_Status	AI	16rruu
IU_rr_uu_HeatTempHiLim_Status	AI	17rruu
IU_rr_uu_SetTemp_Setting	AO	10rruu
IU_rr_uu_AutoTempLoLim_Setting	AO	11rruu
IU_rr_uu_AutoTempHiLim_Setting	AO	12rruu
IU_rr_uu_CoolTempLoLim_Setting	AO	13rruu
IU_rr_uu_CoolTempHiLim_Setting	AO	14rruu
IU_rr_uu_HeatTempLoLim_Setting	AO	15rruu
IU_rr_uu_HeatTempHiLim_Setting	AO	16rruu
IU_rr_uu_Exists_Status	BI	10rruu
IU_rr_uu_Operation_Status	BI	11rruu
IU_rr_uu_ThermostatOFF_Status	BI	12rruu
IU_rr_uu_FilterSign_Status	BI	13rruu
IU_rr_uu_Emergency_Status	BI	14rruu
IU_rr_uu_Error_Status	BI	15rruu
IU_rr_uu_TempLimValid_Status	BI	16rruu
IU_rr_uu_Operation_Setting	BO	10rruu
IU_rr_uu_ThermostatOFF_Setting	BO	11rruu
IU_rr_uu_Reset_Filter_Setting	BO	12rruu
IU_rr_uu_TempLimValid_Setting	BO	13rruu
IU_rr_uu_OperationMode_Status	MI	10rruu
IU_rr_uu_FanSpeed_Status	MI	11rruu

IU_rr_uu_AirFlowDirVT_Status	MI	12rruu
IU_rr_uu_AirFlowDirHZ_Status	MI	13rruu
IU_rr_uu_RC_Prohibit_Status	MI	14rruu
IU_rr_uu_ErrorCode_Status	MI	15rruu
IU_rr_uu_Managed_Mode_Status	MI	16rruu
IU_rr_uu_OperationMode_Setting	MO	10rruu
IU_rr_uu_FanSpeed_Setting	MO	11rruu
IU_rr_uu_AirFlowDirVT_Setting	MO	12rruu
IU_rr_uu_AirFlowDirHZ_Setting	MO	13rruu
IU_rr_uu_RC_Prohibit_Setting	MO	14rruu

5.2.4 Type: Outdoor Unit

Object-name	Object-type	Object-instance
OU_rr_uu_Error_Status	BI	30rruu
OU_rr_uu_ForcedOff_Status	BI	31rruu
OU_rr_uu_ForcedOff_Setting	BO	30rruu
OU_rr_uu_ErrorCode_Status	MI	31rruu
OU_rr_uu_CapacitySave_Status	MI	32rruu
OU_rr_uu_LowNoiseOp_Status	MI	33rruu
OU_rr_uu_LowNoiseOp_Setting	MO	30rruu
OU_rr_uu_CapacitySave_Setting	MO	32rruu

5.3 Objects and properties

Below you can find relevant information for the objects and properties.

Object_Identifier: In the **Device Object**, the value of object instance is configurable through Configuration Tool. See Table 5.1 to obtain the name of each object.

Variable	Description
"rr"	Refrigerant Address (0..99)
"uu"	Outdoor Unit address (0..3)
	Indoor Unit address (0..63)

Table 5.1 Objects and properties variables and descriptions

Object_Name: In the **Device Object**, this string is configurable through Configuration Tool. See Table 5.1 to obtain the name of each object.

Description: In the **Device Object**, this string is configurable through Configuration Tool. See Table 5.1 to obtain the description of each object.

Relinquish_Default: In **Binary Outputs**, **Multistate Outputs** and **Multistate Values**, the value of *Present_Value* property will be read.

Priority_Array: In **Binary Outputs**, **Multistate Outputs** and **Multistate Values**, *Priority_Array[16]* will acquire the value of *Present_Value* property and *Priority_Array[1]~[15]* will be NULL.

State_Text: In **Multistate Outputs**, **Multistate Outputs** and **Multistate Values**, it cannot be read the whole array at once, so "Array Index" must be specified in order to obtain the text of the corresponding state.

IMPORTANT

1. Write the Present_Value of each object in accordance with the limitation of the actual unit to be controlled. If the value that are not within the permissible value of the corresponding unit is written, BACnet Gateway assumes no guarantee on the actual operation of the unit. The range of values specified for objects in this manual, does not reflect the limitation of various types of units that are supported by this product. Refer to the manual of each unit, or other technical documents provided for each product line-ups, for the permissible values of each unit.
2. All control signals such as Operation Mode Setting, Temperature Setting and FAN Speed Setting are accepted when indoor unit is "ON".
3. BACnet Gateway for VRF System requires that the control packets (WriteProperty services) received on the BACnet/IP side to be spaced with at least 300ms interval. The interval is required to transfer the received packet from the high speed BACnet/IP side toward the low speed VRF system side. Not doing so may result in loss of packets.
4. When BACnet Gateway is connected to single units thru Single Split Convertors (eg. UTY-VTGX), certain restrictions apply, due to the limited features supported by the single split convertors. See below.

Features			Availability		Support by UTY-VTG*/UTY-VTG*V	
			Monitor	Control	When connecting to 2w R/C line	When connecting to 3w R/C line
For End Users	Basic	Operation on/off	A	A	ok	ok
		Operation mode	A	A	ok	ok
		Setpoint temperature	A	A	ok (in unit of 0.5deg)	ok (in unit of 1deg)
		Fan	A	A	ok	ok
	Air flow direction	Vertical	A	A	ok	not supported
		Horizontal	A	A	ok	not supported
	Room sensors	Intake temperature (R/C)	A	NA	not supported	not supported
Filter sign status/reset		A	A	ok	ok	
For Administrators	Restrictions	R/C prohibition	A	A	ok	ok (ON prohibit not supported)
	Economy saving	Temperature setpoint limit	A	A	not supported	not supported
		Outdoor capacity save	A	A	not supported	not supported
		Outdoor forced off	A	A	not supported	not supported
		Forced thermo off	A	A	not supported	not supported
	Outdoor low noise operation		A	A	not supported	not supported
Error monitoring	Error state, code	A	NA	ok	ok (5U.1 only for some model)	

5.3.1 Fujitsu AC Gateway (Device Object Type)

Property Identifier	Property Datatype	Value	ASHRAE	UTY-VBGX
Object_Identifier	BACnetObjectIdentifier	(Device, 144)	R	R
Object_Name	CharacterString	"Device UTY-VBGX"	R	R
Object_Type	BACnetObjectType	DEVICE (8) (Device Object Type)	R	R
System_Status	BACnetDeviceStatus	OPERATIONAL (0)	R	R
Vendor_Name	CharacterString	"FUJITSU GENERAL LIMITED"	R	R
Vendor_Identifier	Unsigned16	144	R	R
Model_Name	CharacterString	"UTY-VBGX"	R	R
Firmware_Revision	CharacterString	"14.1.2.0" (Example value)	R	R
Application_Software_Version	CharacterString	"1.1.3.0" (Example value)	R	R
Location	CharacterString	-	O	-
Description	CharacterString	"BACnet Gateway for VRF System"	O	-
Protocol_Version	Unsigned	1	R	R
Protocol_Revision	Unsigned	14	R	R
Protocol_Services_Supported	BACnetServiceSupported	Refer to section 4 [Service Types].	R	R
Protocol_Object_Types_Supported	BACnetObjectTypes Supported	Refer to section 5.1 [Object Types].	R	R
Object_List	BACnetArray[N] of BACnetObjectIdentifier	BACnetARRAY[N]	R	R
Structured_Object_List	BACnetArray[N] of BACnetObjectIdentifier	-	O	-
Max_APDU_Length_Accepted	Unsigned	1476	R	R
Segmentation_Supported	BACnetSegmentation	SEGMENTED-BOTH (0)	R	R
Max_Segments_accepted	Unsigned	16	O	R
VT_Classes_Supported	List of BACnetVTClass	-	O	-
Active_VT_Sessions	List of BACnetVTSession	-	O	-
Local_Date	Date	Current date	O	R
Local_Time	Time	Current time	O	R
UTC_Offset	INTEGER	-	O	-
Daylight_Savings_Status	BOOLEAN	-	O	-
APDU_Segment_Timeout	Unsigned	3000	R	R
APDU_Timeout	Unsigned	3000	R	R
Number_of_APDU_Retries	Unsigned	3	R	R
Time_Synchronization_Recipients	List of BACnetRecipient	-	O	-

Max_Master	Unsigned	-	O	-
Max_Info_Frames	Unsigned	-	O	-
Device_Address_Binding	List of BACnetAddressBinding	NULL (empty)	R	R
Database_Revision	Unsigned	0	R	R
Configuration_Files	BACnetArray[N] of BACnetObjectIdentifier	-	O	-
Last_Restore_Time	BACnetTimeStamp	-	O	-
Backup_Failure_Timeout	Unsigned16	-	O	-
Backup_Preparation_Time	Unsigned16	-	O	-
Restore_Preparation_Time	Unsigned16	-	O	-
Restore_Completion_Time	Unsigned16	-	O	-
Backup_And_Restore_State	BACnetBackupState	-	O	-
Active_COV_Subscriptions	List of BACnetCOVSubscription	List of BACnetCOVSubscription	O	R
Slave_Proxy_Enable	BACnetArray[N] of BOOLEAN	-	O	-
Manual_Slave_Address_Binding	List of BACnetAddressBinding	-	O	-
Auto_Slave_Discovery	BACnetArray[N] of BOOLEAN	-	O	-
Slave_Address_Binding	BACnetAddressBinding	-	O	-
Last_Restart_Reason	BACnetRestartReason	-	O	-
Time_Of_Device_Restart	BACnetTimeStamp	-	O	-
Restart_Notification_Recipients	List of BACnetRecipient	-	O	-
UTC_Time_Synchronization_Recipients	List of BACnetRecipient	-	O	-
Time_Synchronization_Interval	Unsigned	-	O	-
Align_Intervals	BOOLEAN	-	O	-
Interval_Offset	Unsigned	-	O	-
Serial_Number	CharacterString	Product serial number of BACnet	O	R
Property_List	BACnetArray[N] of BACnetPropertyIdentifier	BACnetArray[N]	R	R
Profile_Name	CharacterString	-	O	-

5.3.2 Gateway_ES_Status (Binary Input Object Type)

The current Energy Saving status can be monitored.

Property Identifier	Property Datatype	Value	ASHRAE	UTY-VBGX
Object_Identifier	BACnetObjectIdentifier	(Binary Input, 0)	R	R
Object_Name	CharacterString	"Gateway_ES_Status"	R	R
Object_Type	BACnetObjectType	BINARY_INPUT (3)	R	R
Present_Value	BACnetBinaryPV	INACTIVE (0) / ACTIVE (1)	R	R
Description	CharacterString	-	O	-
Device_Type	CharacterString	-	O	-
Status_Flags	BACnetStatusFlags	{FALSE, FALSE/TRUE, FALSE, FALSE}	R	R
Event_State	BACnetEventState	STATE_NORMAL (0)	R	R
Reliability	BACnetReliability	NO_FAULT_DETECTED (0), UNRELIABLE_OTHER (7)	O	R
Out_Of_Service	BOOLEAN	FALSE	R	R
Polarity	BACnetPolarity	NORMAL (0)	R	R
Inactive_Text	CharacterString	"Not Used"	O	R
Active_Text	CharacterString	"Energy Saving"	O	R
Change_Of_State_Time	BACnetDatetime	-	O	-
Change_Of_State_Count	Unsigned	-	O	-
Time_Of_State_Count_Reset	BACnetDatetime	-	O	-
Elapsed_Active_Time	Unsigned	-	O	-
Time_Of_Active_Time_Reset	BACnetDatetime	-	O	-
Time_Delay	Unsigned	-	O	R*
Notification_Class	Unsigned	-	O	R*
Alarm_Value	BACnetBinaryPV	-	O	R*
Event_Enable	BACnetEventTransitionBits	-	O	R*
Acked_Transitions	BACnetEventTransitionBits	-	O	R*
Notify_Type	BACnetNotifyType	-	O	R*
Event_Time_Stamps	BACnetArray[N] of BACnetTimeStamp	-	O	R*
Event_Message_Texts	BACnetArray[3] of CharacterString	-	O	-
Event_Message_Texts_Config	BACnetArray[3] of CharacterString	-	O	-
Event_Detection_Enable	BOOLEAN	-	O	R*
Event_Algorithm_Inhibit_Ref	BACnetObjectPropertyReference	-	O	-
Event_Algorithm_Inhibit	BOOLEAN	-	O	-
Time_Delay_Normal	Unsigned	-	O	-

Reliability_Evaluation_Inhibit	BOOLEAN	-	O	-
Property_List	BACnetArray[N] of BACnetPropertyIdentifier	BACnetArray[N]	R	R
Profile_Name	CharacterString	-	O	-

* Only available when specific object has a Notification Class configured

5.3.3 Gateway_ES_Setting (Binary Output Object Type)

The current Energy Saving status can be set.

Property Identifier	Property Datatype	Value	ASHRAE	UTY-VBGX
Object_Identifier	BACnetObjectIdentifier	(Binary Output, 0)	R	R
Object_Name	CharacterString	"Gateway_ES_Setting"	R	R
Object_Type	BACnetObjectType	BINARY_OUTPUT (4)	R	R
Present_Value	BACnetBinaryPV	INACTIVE (0) / ACTIVE (1)	W	W
Description	CharacterString	-	O	-
Device_Type	CharacterString	-	O	-
Status_Flags	BACnetStatusFlags	{FALSE, FALSE, FALSE, FALSE}	R	R
Event_State	BACnetEventState	STATE_NORMAL (0)	R	R
Reliability	BACnetReliability	NO_FAULT_DETECTED (0)	O	R
Out_Of_Service	BOOLEAN	FALSE	R	R
Polarity	BACnetPolarity	NORMAL (0)	R	R
Inactive_Text	CharacterString	"Not Used"	O	R
Active_Text	CharacterString	"Energy Saving"	O	R
Change_Of_State_Time	BACnetDatetime	-	O	-
Change_Of_State_Count	Unsigned	-	O	-
Time_Of_State_Count_Reset	BACnetDatetime	-	O	-
Elapsed_Active_Time	Unsigned	-	O	-
Time_Of_Active_Time_Reset	BACnetDatetime	-	O	-
Minimum_Off_Time	Unsigned32	-	O	--
Minimum_On_Time	Unsigned32	-	O	-
Priority_Array	BACnetPriorityArray	BACnetPriorityArray	R	R
Relinquish_Default	BACnetBinaryPV	INACTIVE (0)	R	R
Time_Delay	Unsigned	-	O	R*
Notification_Class	Unsigned	-	O	R*
Feedback_Value	BACnetBinaryPV	-	O	W
Event_Enable	BACnetEventTransitionBits	-	O	R*
Acked_Transitions	BACnetEventTransitionBits	-	O	R*
Notify_Type	BACnetNotifyType	-	O	R*
Event_Time_Stamps	BACnetArray[N] of BACnetTimeStamp	-	O	R*
Event_Message_Texts	BACnetArray[3] of CharacterString	-	O	-
Event_Message_Texts_Config	BACnetArray[3] of CharacterString	-	O	-

Event_Detection_Enable	BOOLEAN		O	R*
Event_Algorithm_Inhibit_Ref	BACnetObjectPropertyReference	-	O	-
Event_Algorithm_Inhibit	BOOLEAN	-	O	-
Time_Delay_Normal	Unsigned	-	O	-
Reliability_Evaluation_Inhibit	BOOLEAN	-	O	-
Property_List	BACnetArray[N] of BACnetPropertyIdentifier	BACnetArray[N]	R	R
Profile_Name	CharacterString	-	O	-

* Only available when specific object has a Notification Class configured

Note. Gateway_ES_Setting may only be set from one unit at a time, within one VRF network.

5.3.4 Gateway_Error_Status (Binary Input Object Type)

The normal and error statuses of the Gateway can be monitored.

Property Identifier	Property Datatype	Value	ASHRAE	UTY-VBGX
Object_Identifier	BACnetObjectIdentifier	(Binary Input, 1)	R	R
Object_Name	CharacterString	"Gateway_Error_Status"	R	R
Object_Type	BACnetObjectType	BINARY_INPUT (3)	R	R
Present_Value	BACnetBinaryPV	INACTIVE (0) / ACTIVE (1)	R	R
Description	CharacterString	-	O	-
Device_Type	CharacterString	-	O	-
Status_Flags	BACnetStatusFlags	{FALSE, FALSE/TRUE, FALSE, FALSE}	R	R
Event_State	BACnetEventState	STATE_NORMAL (0)	R	R
Reliability	BACnetReliability	NO_FAULT_DETECTED (0), UNRELIABLE_OTHER (7)	O	R
Out_Of_Service	BOOLEAN	FALSE	R	R
Polarity	BACnetPolarity	NORMAL (0)	R	R
Inactive_Text	CharacterString	"Normal"	O	R
Active_Text	CharacterString	"Abnormal"	O	R
Change_Of_State_Time	BACnetDatetime	-	O	R
Change_Of_State_Count	Unsigned	-	O	R
Time_Of_State_Count_Reset	BACnetDatetime	-	O	R
Elapsed_Active_Time	Unsigned	-	O	R
Time_Of_Active_Time_Reset	BACnetDatetime	-	O	R
Time_Delay	Unsigned	-	O	R*
Notification_Class	Unsigned	-	O	R*
Alarm_Value	BACnetBinaryPV	-	O	R*
Event_Enable	BACnetEventTransitionBits	-	O	R*
Acked_Transitions	BACnetEventTransitionBits	-	O	R*
Notify_Type	BACnetNotifyType	-	O	R*
Event_Time_Stamps	BACnetArray[N] of BACnetTimeStamp	-	O	R*
Event_Message_Texts	BACnetArray[3] of CharacterString	-	O	-
Event_Message_Texts_Config	BACnetArray[3] of CharacterString	-	O	-
Event_Detection_Enable	BOOLEAN	-	O	R*
Event_Algorithm_Inhibit_Ref	BACnetObjectPropertyReference	-	O	-
Event_Algorithm_Inhibit	BOOLEAN	-	O	-
Time_Delay_Normal	Unsigned	-	O	-

Reliability_Evaluation_Inhibit	BOOLEAN	-	O	-
Property_List	BACnetArray[N] of BACnetPropertyIdentifier	BACnetArray[N]	R	R
Profile_Name	CharacterString	-	O	-

* Only available when specific object has a Notification Class configured

5.3.5 Gateway_ErrorCode_Status (Multistate Input Object Type)

The error code when a Gateway error occurs can be checked.

Property Identifier	Property Datatype	Value	ASHRAE	UTY-VBGX
Object_Identifier	BACnetObjectIdentifier	(Multistate Input, 0)	R	R
Object_Name	CharacterString	"Gateway_ErrorCode_Status"	R	R
Object_Type	BACnetObjectType	MULTISTATE_INPUT (13)	R	R
Present_Value	Unsigned	1 ~ 3	R	R
Description	CharacterString	-	O	-
Device_Type	CharacterString	-	O	-
Status_Flags	BACnetStatusFlags	{FALSE, FALSE/TRUE, FALSE, FALSE}	R	R
Event_State	BACnetEventState	STATE_NORMAL (0)	R	R
Reliability	BACnetReliability	NO_FAULT_DETECTED (0), UNRELIABLE_OTHER (7)	O	R
Out_Of_Service	BOOLEAN	FALSE	R	R
Number_Of_States	Unsigned	3	R	R
State_Text	BACnetArray[N] of CharacterString	-	O	-
Time_Delay	Unsigned	-	O	R*
Notification_Class	Unsigned	-	O	R*
Alarm_Values	List of Unsigned	-	O	R*
Fault_Values	List of Unsigned	-	O	R*
Event_Enable	BACnetEventTransitionBits	-	O	R*
Acked_Transitions	BACnetEventTransitionBits	-	O	R*
Notify_Type	BACnetNotifyType	-	O	R*
Event_Time_Stamps	BACnetArray[N] of BACnetTimeStamp	-	O	R*
Event_Message_Texts	BACnetArray[3] of CharacterString	-	O	-
Event_Message_Texts_Config	BACnetArray[3] of CharacterString	-	O	-
Event_Detection_Enable	BOOLEAN	-	O	R*
Event_Algorithm_Inhibit_Ref	BACnetObjectPropertyReference	-	O	-
Event_Algorithm_Inhibit	BOOLEAN	-	O	-
Time_Delay_Normal	Unsigned	-	O	-
Reliability_Evaluation_Inhibit	BOOLEAN	-	O	-
Property_List	BACnetArray[N] of BACnetPropertyIdentifier	BACnetArray[N]	R	R
Profile_Name	CharacterString	-	O	-

* Only available when specific object has a Notification Class configured

Gateway Error Code table

Gateway Error Code can be interpreted using the values in the following correspondence table.

Pesent_Value	Description
1	No Error
2	Hardware Error

5.3.6 Batch_SetTemp_Setting (Analog Output Object Type)

Property Identifier	Property Datatype	Value	ASHRAE	UTY-VBGX
Object_Identifier	BACnetObjectIdentifier	(Analog Output, 0)	R	R
Object_Name	CharacterString	"Batch_SetTemp_Setting"	R	R
Object_Type	BACnetObjectType	ANALOG_OUTPUT (1)	R	R
Present_Value	REAL	10 ~ 30(°C) // 48 ~ 88(°F)	W	W
Description	CharacterString	-	O	-
Device_Type	CharacterString	-	O	-
Status_Flags	BACnetStatusFlags	{FALSE, FALSE, FALSE, FALSE}	R	R
Event_State	BACnetEventState	STATE_NORMAL (0)	R	R
Reliability	BACnetReliability	NO_FAULT_DETECTED (0)	O	R
Out_Of_Service	BOOLEAN	FALSE	R	R
Update_Interval	Unsigned	-	O	-
Units	BACnetEngineeringUnits	Degrees Celsius (62) // Fahrenheit (64)	R	R
Min_Pres_Value	REAL	-	O	-
Max_Pres_Value	REAL	-	O	-
Resolution	REAL	-	O	-
COV_Increment	REAL	1	O	R
Priority_Array	BACnetPriorityArray	BACnetPriorityArray	R	R
Relinquish_Default	Unsigned	26	R	R
Time_Delay	Unsigned	-	O	R*
Notification_Class	Unsigned	-	O	R*
High_Limit	REAL	-	O	R*
Low_Limit	REAL	-	O	R*
Deadband	REAL	-	O	R*
Limit_Enable	BACnetLimitEnable	-	O	R*
Event_Enable	BACnetEventTransitionBits	-	O	R*
Acked_Transitions	BACnetEventTransitionBits	-	O	R*
Notify_Type	BACnetNotifyType	-	O	R*
Event_Time_Stamps	BACnetArray[N] of BACnetTimeStamp	-	O	R*
Event_Message_Texts	BACnetArray[3] of CharacterString	-	O	-
Event_Message_Texts_Config	BACnetArray[3] of CharacterString	-	O	-
Event_Detection_Enable	BOOLEAN	-	O	R*

Event_Algorithm_Inhibit_Ref	BACnetObjectPropertyReference	-	O	-
Event_Algorithm_Inhibit	BOOLEAN	-	O	-
Time_Delay_Normal	Unsigned	-	O	-
Reliability_Evaluation_Inhibit	BOOLEAN	-	O	-
Property_List	BACnetArray[N] of BACnetPropertyIdentifier	BACnetArray[N]	R	R
Profile_Name	CharacterString	-	O	-

* Only available when specific object has a Notification Class configured

5.3.7 Batch_Operation_Setting (Binary Output Object Type)

Property Identifier	Property Datatype	Value	ASHRAE	UTY-VBGX
Object_Identifier	BACnetObjectIdentifier	(Binary Output, 1)	R	R
Object_Name	CharacterString	"Batch_Operation_Setting"	R	R
Object_Type	BACnetObjectType	BINARY_OUTPUT (4)	R	R
Present_Value	BACnetBinaryPV	INACTIVE (0) / ACTIVE (1)	W	W
Description	CharacterString	-	O	-
Device_Type	CharacterString	-	O	-
Status_Flags	BACnetStatusFlags	{FALSE, FALSE, FALSE, FALSE}	R	R
Event_State	BACnetEventState	STATE_NORMAL (0)	R	R
Reliability	BACnetReliability	NO_FAULT_DETECTED (0)	O	R
Out_Of_Service	BOOLEAN	FALSE	R	R
Polarity	BACnetPolarity	NORMAL (0)	R	R
Inactive_Text	CharacterString	"Off"	O	R
Active_Text	CharacterString	"On"	O	R
Change_Of_State_Time	BACnetDatetime	-	O	R
Change_Of_State_Count	Unsigned	-	O	R
Time_Of_State_Count_Reset	BACnetDatetime	-	O	R
Elapsed_Active_Time	Unsigned	-	O	R
Time_Of_Active_Time_Reset	BACnetDatetime	-	O	R
Minimum_Off_Time	Unsigned32	-	O	-
Minimum_On_Time	Unsigned32	-	O	-
Priority_Array	BACnetPriorityArray	BACnetPriorityArray	R	R
Relinquish_Default	BACnetBinaryPV	INACTIVE (0)	R	R
Time_Delay	Unsigned	-	O	R*
Notification_Class	Unsigned	-	O	R*
Feedback_Value	BACnetBinaryPV	-	O	W
Event_Enable	BACnetEventTransitionBits	-	O	R*
Acked_Transitions	BACnetEventTransitionBits	-	O	R*
Notify_Type	BACnetNotifyType	-	O	R*
Event_Time_Stamps	BACnetArray[N] of BACnetTimeStamp	-	O	R*
Event_Message_Texts	BACnetArray[3] of CharacterString	-	O	-
Event_Message_Texts_Config	BACnetArray[3] of CharacterString	-	O	-

Event_Detection_Enable	BOOLEAN	-	O	R*-
Event_Algorithm_Inhibit_Ref	BACnetObjectPropertyReference	-	O	-
Event_Algorithm_Inhibit	BOOLEAN	-	O	-
Time_Delay_Normal	Unsigned	-	O	-
Reliability_Evaluation_Inhibit	BOOLEAN	-	O	-
Property_List	BACnetArray[N] of BACnetPropertyIdentifier	BACnetArray[N]	R	R
Profile_Name	CharacterString	-	O	-

* Only available when specific object has a Notification Class configured

5.3.8 Batch_OperationMode_Setting (Multistate Output Object Type)

Property Identifier	Property Datatype	Value	ASHRAE	UTY-VBGX
Object_Identifier	BACnetObjectIdentifier	(Multistate Output, 0)	R	R
Object_Name	CharacterString	"Batch_OperationMode_Setting"	R	R
Object_Type	BACnetObjectType	MULTISTATE_OUTPUT (14)	R	R
Present_Value	Unsigned	1 ~ 5	W	W
Description	CharacterString	-	O	-
Device_Type	CharacterString	-	O	-
Status_Flags	BACnetStatusFlags	{FALSE, FALSE, FALSE, FALSE}	R	R
Event_State	BACnetEventState	STATE_NORMAL (0)	R	R
Reliability	BACnetReliability	NO_FAULT_DETECTED (0)	O	R
Out_Of_Service	BOOLEAN	FALSE	R	R
Number_Of_States	Unsigned	5	R	R
State_Text	BACnetArray[N] of CharacterString	<i>Check Operation Mode settings below</i>	O	R
Priority_Array	BACnetPriorityArray	BACnetPriorityArray	R	R
Relinquish_Default	Unsigned	1	R	R
Time_Delay	Unsigned	-	O	R*
Notification_Class	Unsigned	-	O	R*
Feedback_Value	Unsigned	-	O	W
Event_Enable	BACnetEventTransitionBits	-	O	R*
Acked_Transitions	BACnetEventTransitionBits	-	O	R*
Notify_Type	BACnetNotifyType	-	O	R*
Event_Time_Stamps	BACnetArray[N] of BACnetTimeStamp	-	O	R*
Event_Message_Texts	BACnetArray[3] of CharacterString	-	O	-
Event_Message_Texts_Config	BACnetArray[3] of CharacterString	-	O	-
Event_Detection_Enable	BOOLEAN	-	O	R*
Event_Algorithm_Inhibit_Ref	BACnetObjectPropertyReference	-	O	-
Event_Algorithm_Inhibit	BOOLEAN	-	O	-
Time_Delay_Normal	Unsigned	-	O	-
Reliability_Evaluation_Inhibit	BOOLEAN	-	O	-
Property_List	BACnetArray[N] of BACnetPropertyIdentifier	BACnetArray[N]	R	R
Profile_Name	CharacterString	-	O	-

* Only available when specific object has a Notification Class configured

Operation Mode settings table

Mode commands can be set using the values in the following correspondence table.

Pesent_Value	Contents displayed in State_Text
1	Cool
2	Heat
3	Fan
4	Dry
5	Auto

5.3.9 Batch_FanSpeed_Setting (Multistate Output Object Type)

Property Identifier	Property Datatype	Value	ASHRAE	UTY-VBGX
Object_Identifier	BACnetObjectIdentifier	(Multistate Output, 1)	R	R
Object_Name	CharacterString	"Batch_FanSpeed_Setting"	R	R
Object_Type	BACnetObjectType	MULTISTATE_OUTPUT (14)	R	R
Present_Value	Unsigned	1 ~ 7	W	W
Description	CharacterString	-	O	-
Device_Type	CharacterString	-	O	-
Status_Flags	BACnetStatusFlags	{FALSE, FALSE, FALSE, FALSE}	R	R
Event_State	BACnetEventState	STATE_NORMAL (0)	R	R
Reliability	BACnetReliability	NO_FAULT_DETECTED (0)	O	R
Out_Of_Service	BOOLEAN	FALSE	R	R
Number_Of_States	Unsigned	7	R	R
State_Text	BACnetArray[N] of CharacterString	<i>Check Fan Speed settings below</i>	O	R
Priority_Array	BACnetPriorityArray	BACnetPriorityArray	R	R
Relinquish_Default	Unsigned	1	R	R
Time_Delay	Unsigned	-	O	R*
Notification_Class	Unsigned	-	O	R*
Feedback_Value	Unsigned	-	O	W
Event_Enable	BACnetEventTransitionBits	-	O	R*
Acked_Transitions	BACnetEventTransitionBits	-	O	R*
Notify_Type	BACnetNotifyType	-	O	R*
Event_Time_Stamps	BACnetArray[N] of BACnetTimeStamp	-	O	R*
Event_Message_Texts	BACnetArray[3] of CharacterString	-	O	-
Event_Message_Texts_Config	BACnetArray[3] of CharacterString	-	O	-
Event_Detection_Enable	BOOLEAN	-	O	R*
Event_Algorithm_Inhibit_Ref	BACnetObjectPropertyReference	-	O	-
Event_Algorithm_Inhibit	BOOLEAN	-	O	-
Time_Delay_Normal	Unsigned	-	O	-
Reliability_Evaluation_Inhibit	BOOLEAN	-	O	-
Property_List	BACnetArray[N] of BACnetPropertyIdentifier	BACnetArray[N]	R	R
Profile_Name	CharacterString	-	O	-

* Only available when specific object has a Notification Class configured

Fan Speed settings table

Fan Speed commands can be set using the values in the following correspondence table.

Pesent_Value	Contents displayed in State_Text
1	Low
2	High
3	Med
4	Auto

Pesent_Value	Contents displayed in State_Text
5	Quiet
6	Med-Low
7	Med-High

5.3.10 Batch_RC_Prohibition_Setting (Multistate Output Object Type)

Property Identifier	Property Datatype	Value	ASHRAE	UTY-VBGX
Object_Identifier	BACnetObjectIdentifier	(Multistate Output, 2)	R	R
Object_Name	CharacterString	"Batch_RC_Prohibition_Setting"	R	R
Object_Type	BACnetObjectType	MULTISTATE_OUTPUT (14)	R	R
Present_Value	Unsigned	1 ~ 65	W	W
Description	CharacterString	-	O	-
Device_Type	CharacterString	-	O	-
Status_Flags	BACnetStatusFlags	{FALSE, FALSE, FALSE, FALSE}	R	R
Event_State	BACnetEventState	STATE_NORMAL (0)	R	R
Reliability	BACnetReliability	NO_FAULT_DETECTED (0)	O	R
Out_Of_Service	BOOLEAN	FALSE	R	R
Number_Of_States	Unsigned	65	R	R
State_Text	BACnetArray[N] of CharacterString	Check RC Prohibition table (section 12.2)	O	R
Priority_Array	BACnetPriorityArray	BACnetPriorityArray	R	R
Relinquish_Default	Unsigned	1	R	R
Time_Delay	Unsigned	-	O	R*
Notification_Class	Unsigned	-	O	R*
Feedback_Value	Unsigned	-	O	W
Event_Enable	BACnetEventTransitionBits	-	O	R*
Acked_Transitions	BACnetEventTransitionBits	-	O	R*
Notify_Type	BACnetNotifyType	-	O	R*
Event_Time_Stamps	BACnetArray[N] of BACnetTimeStamp	-	O	R*
Event_Message_Texts	BACnetArray[3] of CharacterString	-	O	-
Event_Message_Texts_Config	BACnetArray[3] of CharacterString	-	O	-
Event_Detection_Enable	BOOLEAN	-	O	R*
Event_Algorithm_Inhibit_Ref	BACnetObjectPropertyReference	-	O	-
Event_Algorithm_Inhibit	BOOLEAN	-	O	-
Time_Delay_Normal	Unsigned	-	O	-
Reliability_Evaluation_Inhibit	BOOLEAN	-	O	-
Property_List	BACnetArray[N] of BACnetPropertyIdentifier	BACnetArray[N]	R	R
Profile_Name	CharacterString	-	O	-

* Only available when specific object has a Notification Class configured

5.3.11 IU_rr_uu_SetTemp_Status (Analog Input Object Type)

Indoor unit temperature setting status can be monitored.

Property Identifier	Property Datatype	Value	ASHRAE	UTY-VBGX
Object_Identifier	BACnetObjectIdentifier	(Analog Input, 10rruu)	R	R
Object_Name	CharacterString	"IU_rr_uu_SetTemp_Status"	R	R
Object_Type	BACnetObjectType	ANALOG_INPUT (0)	R	R
Present_Value	REAL	10 ~ 30(°C) // 48 ~ 88(°F)	R	R
Description	CharacterString	-	O	-
Device_Type	CharacterString	-	O	-
Status_Flags	BACnetStatusFlags	{FALSE, FALSE/TRUE, FALSE, FALSE}	R	R
Event_State	BACnetEventState	STATE_NORMAL (0)	R	R
Reliability	BACnetReliability	NO_FAULT_DETECTED (0), UNRELIABLE_OTHER (7)	O	R
Out_Of_Service	BOOLEAN	FALSE	R	R
Update_Interval	Unsigned	-	O	-
Units	BACnetEngineeringUnits	Degrees Celsius (62) / Fahrenheit (64)	R	R
Min_Pres_Value	REAL	-	O	-
Max_Pres_Value	REAL	-	O	-
Resolution	REAL	-	O	-
COV_Increment	REAL	0	O	R
Time_Delay	Unsigned	-	O	R*
Notification_Class	Unsigned	-	O	R*
High_Limit	REAL	-	O	R*
Low_Limit	REAL	-	O	R*
Deadband	REAL	-	O	R*
Limit_Enable	BACnetLimitEnable	-	O	R*
Event_Enable	BACnetEventTransitionBits	-	O	R*
Acked_Transitions	BACnetEventTransitionBits	-	O	R*
Notify_Type	BACnetNotifyType	-	O	R*
Event_Time_Stamps	BACnetArray[N] of BACnetTimeStamp	-	O	R*
Event_Message_Texts	BACnetArray[3] of CharacterString	-	O	-
Event_Message_Texts_Config	BACnetArray[3] of CharacterString	-	O	-
Event_Detection_Enable	BOOLEAN	-	O	R*
Event_Algorithm_Inhibit_Ref	BACnetObjectPropertyReference	-	O	-
Event_Algorithm_Inhibit	BOOLEAN	-	O	-

Time_Delay_Normal	Unsigned	-	O	-
Reliability_Evaluation_Inhibit	BOOLEAN	-	O	-
Property_List	BACnetArray[N] of BACnetPropertyIdentifier	BACnetArray[N]	R	R
Profile_Name	CharacterString	-	O	-

* Only available when specific object has a Notification Class configured

5.3.12 IU_rr_uu_SpaceTemp_Status (Analog Input Object Type)

Indoor unit surrounding temperature status can be monitored.

Property Identifier	Property Datatype	Value	ASHRAE	UTY-VBGX
Object_Identifier	BACnetObjectIdentifier	(Analog Input, 11rruu)	R	R
Object_Name	CharacterString	"IU_rr_uu_SpaceTemp_Status"	R	R
Object_Type	BACnetObjectType	ANALOG_INPUT (0)	R	R
Present_Value	REAL	0 ~ 63.5(°C) // 30 ~ 148(°F)	R	R
Description	CharacterString	-	O	-
Device_Type	CharacterString	-	O	-
Status_Flags	BACnetStatusFlags	{FALSE, FALSE/TRUE, FALSE, FALSE}	R	R
Event_State	BACnetEventState	STATE_NORMAL (0)	R	R
Reliability	BACnetReliability	NO_FAULT_DETECTED (0), UNRELIABLE_OTHER (7)	O	R
Out_Of_Service	BOOLEAN	FALSE	R	R
Update_Interval	Unsigned	-	O	-
Units	BACnetEngineeringUnits	Degrees Celsius (62) // Fahrenheit (64)	R	R
Min_Pres_Value	REAL	-	O	-
Max_Pres_Value	REAL	-	O	-
Resolution	REAL	-	O	-
COV_Increment	REAL	0	O	R
Time_Delay	Unsigned	-	O	R*
Notification_Class	Unsigned	-	O	R*
High_Limit	REAL	-	O	R*
Low_Limit	REAL	-	O	R*
Deadband	REAL	-	O	R*
Limit_Enable	BACnetLimitEnable	-	O	R*
Event_Enable	BACnetEventTransitionBits	-	O	R*
Acked_Transitions	BACnetEventTransitionBits	-	O	R*
Notify_Type	BACnetNotifyType	-	O	R*
Event_Time_Stamps	BACnetArray[N] of BACnetTimeStamp	-	O	R*
Event_Message_Texts	BACnetArray[3] of CharacterString	-	O	-
Event_Message_Texts_Config	BACnetArray[3] of CharacterString	-	O	-
Event_Detection_Enable	BOOLEAN	-	O	R*
Event_Algorithm_Inhibit_Ref	BACnetObjectPropertyReference	-	O	-
Event_Algorithm_Inhibit	BOOLEAN	-	O	-

Time_Delay_Normal	Unsigned	-	O	-
Reliability_Evaluation_Inhibit	BOOLEAN	-	O	-
Property_List	BACnetArray[N] of BACnetPropertyIdentifier	BACnetArray[N]	R	R
Profile_Name	CharacterString	-	O	-

* Only available when specific object has a Notification Class configured

The room temperature monitored by the air conditioner fluctuates depending on the place where the sensor is installed.

*If optional equipment for measurement is installed in the indoor unit, it can be used at room temperature.

Data sent as "Space Temperature" is a data used for controlling units.

They may have values different from the actual room temperature in some cases like when the operation mode is changed.

When using this data for operation control as in setting operation mode and temperature, beware of the above and use it at the discretion of the user.

5.3.13 IU_rr_uu_AutoTempLoLim_Status (Analog Input Object Type)

The indoor unit temperature lower limit values status when Auto Mode is active can be monitored.

Property Identifier	Property Datatype	Value	ASHRAE	UTY-VBGX
Object_Identifier	BACnetObjectIdentifier	(Analog Input, 12rruu)	R	R
Object_Name	CharacterString	"IU_rr_uu_AutoTempLoLim_Status"	R	R
Object_Type	BACnetObjectType	ANALOG_INPUT (0)	R	R
Present_Value	REAL	18 ~ 30(°C) // 64 ~ 88(°F)	R	R
Description	CharacterString	-	O	-
Device_Type	CharacterString	-	O	-
Status_Flags	BACnetStatusFlags	{FALSE, FALSE/TRUE, FALSE, FALSE}	R	R
Event_State	BACnetEventState	STATE_NORMAL (0)	R	R
Reliability	BACnetReliability	NO_FAULT_DETECTED (0), UNRELIABLE_OTHER (7)	O	R
Out_Of_Service	BOOLEAN	FALSE	R	R
Update_Interval	Unsigned	-	O	-
Units	BACnetEngineeringUnits	Degrees Celsius (62) // Fahrenheit (64)	R	R
Min_Pres_Value	REAL	-	O	-
Max_Pres_Value	REAL	-	O	-
Resolution	REAL	-	O	-
COV_Increment	REAL	0	O	R
Time_Delay	Unsigned	-	O	R*
Notification_Class	Unsigned	-	O	R*
High_Limit	REAL	-	O	R*
Low_Limit	REAL	-	O	R*
Deadband	REAL	-	O	R*
Limit_Enable	BACnetLimitEnable	-	O	R*
Event_Enable	BACnetEventTransitionBits	-	O	R*
Acked_Transitions	BACnetEventTransitionBits	-	O	R*
Notify_Type	BACnetNotifyType	-	O	R*
Event_Time_Stamps	BACnetArray[N] of BACnetTimeStamp	-	O	R*
Event_Message_Texts	BACnetArray[3] of CharacterString	-	O	-
Event_Message_Texts_Config	BACnetArray[3] of CharacterString	-	O	-
Event_Detection_Enable	BOOLEAN	-	O	R*-
Event_Algorithm_Inhibit_Ref	BACnetObjectPropertyReference	-	O	-
Event_Algorithm_Inhibit	BOOLEAN	-	O	-

Time_Delay_Normal	Unsigned	-	O	-
Reliability_Evaluation_Inhibit	BOOLEAN	-	O	-
Property_List	BACnetArray[N] of BACnetPropertyIdentifier	BACnetArray[N]	R	R
Profile_Name	CharacterString	-	O	-

* Only available when specific object has a Notification Class configured

5.3.14 IU_rr_uu_AutoTempHiLim_Status (Analog Input Object Type)

The indoor unit temperature upper limit values status when Auto Mode is active can be monitored.

Property Identifier	Property Datatype	Value	ASHRAE	UTY-VBGX
Object_Identifier	BACnetObjectIdentifier	(Analog Input, 13rruu)	R	R
Object_Name	CharacterString	"IU_rr_uu_AutoTempHiLim_Status"	R	R
Object_Type	BACnetObjectType	ANALOG_INPUT (0)	R	R
Present_Value	REAL	18 ~ 30(°C) // 64 ~ 88(°F)	R	R
Description	CharacterString	-	O	-
Device_Type	CharacterString	-	O	-
Status_Flags	BACnetStatusFlags	{FALSE, FALSE/TRUE, FALSE, FALSE}	R	R
Event_State	BACnetEventState	STATE_NORMAL (0)	R	R
Reliability	BACnetReliability	NO_FAULT_DETECTED (0), UNRELIABLE_OTHER (7)	O	R
Out_Of_Service	BOOLEAN	FALSE	R	R
Update_Interval	Unsigned	-	O	-
Units	BACnetEngineeringUnits	Degrees Celsius (62) // Fahrenheit (64)	R	R
Min_Pres_Value	REAL	-	O	-
Max_Pres_Value	REAL	-	O	-
Resolution	REAL	-	O	-
COV_Increment	REAL	0	O	R
Time_Delay	Unsigned	-	O	R*
Notification_Class	Unsigned	-	O	R*
High_Limit	REAL	-	O	R*
Low_Limit	REAL	-	O	R*
Deadband	REAL	-	O	R*
Limit_Enable	BACnetLimitEnable	-	O	R*
Event_Enable	BACnetEventTransitionBits	-	O	R*
Acked_Transitions	BACnetEventTransitionBits	-	O	R*
Notify_Type	BACnetNotifyType	-	O	R*
Event_Time_Stamps	BACnetArray[N] of BACnetTimeStamp	-	O	R*
Event_Message_Texts	BACnetArray[3] of CharacterString	-	O	-
Event_Message_Texts_Config	BACnetArray[3] of CharacterString	-	O	-
Event_Detection_Enable	BOOLEAN	-	O	R*
Event_Algorithm_Inhibit_Ref	BACnetObjectPropertyReference	-	O	-
Event_Algorithm_Inhibit	BOOLEAN	-	O	-

Time_Delay_Normal	Unsigned	-	O	-
Reliability_Evaluation_Inhibit	BOOLEAN	-	O	-
Property_List	BACnetArray[N] of BACnetPropertyIdentifier	BACnetArray[N]	R	R
Profile_Name	CharacterString	-	O	-

* Only available when specific object has a Notification Class configured

5.3.15 IU_rr_uu_CoolTempLoLim_Status (Analog Input Object Type)

The indoor unit temperature lower limit values status when Cool Mode is active can be monitored.

Property Identifier	Property Datatype	Value	ASHRAE	UTY-VBGX
Object_Identifier	BACnetObjectIdentifier	(Analog Input, 14rruu)	R	R
Object_Name	CharacterString	"IU_rr_uu_CoolTempLoLim_Status"	R	R
Object_Type	BACnetObjectType	ANALOG_INPUT (0)	R	R
Present_Value	REAL	18 ~ 30(°C) // 64 ~ 88(°F)	R	R
Description	CharacterString	-	O	-
Device_Type	CharacterString	-	O	-
Status_Flags	BACnetStatusFlags	{FALSE, FALSE/TRUE, FALSE, FALSE}	R	R
Event_State	BACnetEventState	STATE_NORMAL (0)	R	R
Reliability	BACnetReliability	NO_FAULT_DETECTED (0), UNRELIABLE_OTHER (7)	O	R
Out_Of_Service	BOOLEAN	FALSE	R	R
Update_Interval	Unsigned	-	O	-
Units	BACnetEngineeringUnits	Degrees Celsius (62) // Fahrenheit (64)	R	R
Min_Pres_Value	REAL	-	O	-
Max_Pres_Value	REAL	-	O	-
Resolution	REAL	-	O	-
COV_Increment	REAL	0	O	R
Time_Delay	Unsigned	-	O	R*
Notification_Class	Unsigned	-	O	R*
High_Limit	REAL	-	O	R*
Low_Limit	REAL	-	O	R*
Deadband	REAL	-	O	R*
Limit_Enable	BACnetLimitEnable	-	O	R*
Event_Enable	BACnetEventTransitionBits	-	O	R*
Acked_Transitions	BACnetEventTransitionBits	-	O	R*
Notify_Type	BACnetNotifyType	-	O	R*
Event_Time_Stamps	BACnetArray[N] of BACnetTimeStamp	-	O	R*
Event_Message_Texts	BACnetArray[3] of CharacterString	-	O	-
Event_Message_Texts_Config	BACnetArray[3] of CharacterString	-	O	-
Event_Detection_Enable	BOOLEAN	-	O	R*
Event_Algorithm_Inhibit_Ref	BACnetObjectPropertyReference	-	O	-
Event_Algorithm_Inhibit	BOOLEAN	-	O	-

Time_Delay_Normal	Unsigned	-	O	-
Reliability_Evaluation_Inhibit	BOOLEAN	-	O	-
Property_List	BACnetArray[N] of BACnetPropertyIdentifier	BACnetArray[N]	R	R
Profile_Name	CharacterString	-	O	-

* Only available when specific object has a Notification Class configured

5.3.16 IU_rr_uu_CoolTempHiLim_Status (Analog Input Object Type)

The indoor unit temperature upper limit values status when Cool Mode is active can be monitored.

Property Identifier	Property Datatype	Value	ASHRAE	UTY-VBGX
Object_Identifier	BACnetObjectIdentifier	(Analog Input, 15rruu)	R	R
Object_Name	CharacterString	"IU_rr_uu_CoolTempHiLim_Status"	R	R
Object_Type	BACnetObjectType	ANALOG_INPUT (0)	R	R
Present_Value	REAL	18 ~ 30(°C) // 64 ~ 88(°F)	R	R
Description	CharacterString	-	O	-
Device_Type	CharacterString	-	O	-
Status_Flags	BACnetStatusFlags	{FALSE, FALSE/TRUE, FALSE, FALSE}	R	R
Event_State	BACnetEventState	STATE_NORMAL (0)	R	R
Reliability	BACnetReliability	NO_FAULT_DETECTED (0), UNRELIABLE_OTHER (7)	O	R
Out_Of_Service	BOOLEAN	FALSE	R	R
Update_Interval	Unsigned	-	O	-
Units	BACnetEngineeringUnits	Degrees Celsius (62) // Fahrenheit (64)	R	R
Min_Pres_Value	REAL	-	O	-
Max_Pres_Value	REAL	-	O	-
Resolution	REAL	-	O	-
COV_Increment	REAL	0	O	R
Time_Delay	Unsigned	-	O	R*
Notification_Class	Unsigned	-	O	R*
High_Limit	REAL	-	O	R*
Low_Limit	REAL	-	O	R*
Deadband	REAL	-	O	R*
Limit_Enable	BACnetLimitEnable	-	O	R*
Event_Enable	BACnetEventTransitionBits	-	O	R*
Acked_Transitions	BACnetEventTransitionBits	-	O	R*
Notify_Type	BACnetNotifyType	-	O	R*
Event_Time_Stamps	BACnetArray[N] of BACnetTimeStamp	-	O	R*
Event_Message_Texts	BACnetArray[3] of CharacterString	-	O	-
Event_Message_Texts_Config	BACnetArray[3] of CharacterString	-	O	-
Event_Detection_Enable	BOOLEAN	-	O	R*
Event_Algorithm_Inhibit_Ref	BACnetObjectPropertyReference	-	O	-
Event_Algorithm_Inhibit	BOOLEAN	-	O	-

Time_Delay_Normal	Unsigned	-	O	-
Reliability_Evaluation_Inhibit	BOOLEAN	-	O	-
Property_List	BACnetArray[N] of BACnetPropertyIdentifier	BACnetArray[N]	R	R
Profile_Name	CharacterString	-	O	-

* Only available when specific object has a Notification Class configured

5.3.17 IU_rr_uu_HeatTempLoLim_Status (Analog Input Object Type)

The indoor unit temperature lower limit values status when Heat Mode is active can be monitored.

Property Identifier	Property Datatype	Value	ASHRAE	UTY-VBGX
Object_Identifier	BACnetObjectIdentifier	(Analog Input, 16rruu)	R	R
Object_Name	CharacterString	"IU_rr_uu_HeatTempLoLim_Status"	R	R
Object_Type	BACnetObjectType	ANALOG_INPUT (0)	R	R
Present_Value	REAL	10 ~ 30(°C) // 48 ~ 88(°F)	R	R
Description	CharacterString	-	O	-
Device_Type	CharacterString	-	O	-
Status_Flags	BACnetStatusFlags	{FALSE, FALSE/TRUE, FALSE, FALSE}	R	R
Event_State	BACnetEventState	STATE_NORMAL (0)	R	R
Reliability	BACnetReliability	NO_FAULT_DETECTED (0), UNRELIABLE_OTHER (7)	O	R
Out_Of_Service	BOOLEAN	FALSE	R	R
Update_Interval	Unsigned	-	O	-
Units	BACnetEngineeringUnits	Degrees Celsius (62) // Fahrenheit (64)	R	R
Min_Pres_Value	REAL	-	O	-
Max_Pres_Value	REAL	-	O	-
Resolution	REAL	-	O	-
COV_Increment	REAL	0	O	R
Time_Delay	Unsigned	-	O	R*
Notification_Class	Unsigned	-	O	R*
High_Limit	REAL	-	O	R*
Low_Limit	REAL	-	O	R*
Deadband	REAL	-	O	R*
Limit_Enable	BACnetLimitEnable	-	O	R*
Event_Enable	BACnetEventTransitionBits	-	O	R*
Acked_Transitions	BACnetEventTransitionBits	-	O	R*
Notify_Type	BACnetNotifyType	-	O	R*
Event_Time_Stamps	BACnetArray[N] of BACnetTimeStamp	-	O	R*
Event_Message_Texts	BACnetArray[3] of CharacterString	-	O	-
Event_Message_Texts_Config	BACnetArray[3] of CharacterString	-	O	-
Event_Detection_Enable	BOOLEAN	-	O	R*
Event_Algorithm_Inhibit_Ref	BACnetObjectPropertyReference	-	O	-
Event_Algorithm_Inhibit	BOOLEAN	-	O	-

Time_Delay_Normal	Unsigned	-	O	-
Reliability_Evaluation_Inhibit	BOOLEAN	-	O	-
Property_List	BACnetArray[N] of BACnetPropertyIdentifier	BACnetArray[N]	R	R
Profile_Name	CharacterString	-	O	-

* Only available when specific object has a Notification Class configured

5.3.18 IU_rr_uu_HeatTempHiLim_Status (Analog Input Object Type)

The indoor unit temperature upper limit values status when Heat Mode is active can be monitored.

Property Identifier	Property Datatype	Value	ASHRAE	UTY-VBGX
Object_Identifier	BACnetObjectIdentifier	(Analog Input, 17rruu)	R	R
Object_Name	CharacterString	"IU_rr_uu_HeatTempHiLim_Status"	R	R
Object_Type	BACnetObjectType	ANALOG_INPUT (0)	R	R
Present_Value	REAL	10 ~ 30(°C) // 48 ~ 88(°F)	R	R
Description	CharacterString	-	O	-
Device_Type	CharacterString	-	O	-
Status_Flags	BACnetStatusFlags	{FALSE, FALSE/TRUE, FALSE, FALSE}	R	R
Event_State	BACnetEventState	STATE_NORMAL (0)	R	R
Reliability	BACnetReliability	NO_FAULT_DETECTED (0), UNRELIABLE_OTHER (7)	O	R
Out_Of_Service	BOOLEAN	FALSE	R	R
Update_Interval	Unsigned	-	O	-
Units	BACnetEngineeringUnits	Degrees Celsius (62) // Fahrenheit (64)	R	R
Min_Pres_Value	REAL	-	O	-
Max_Pres_Value	REAL	-	O	-
Resolution	REAL	-	O	-
COV_Increment	REAL	0	O	R
Time_Delay	Unsigned	-	O	R*
Notification_Class	Unsigned	-	O	R*
High_Limit	REAL	-	O	R*
Low_Limit	REAL	-	O	R*
Deadband	REAL	-	O	R*
Limit_Enable	BACnetLimitEnable	-	O	R*
Event_Enable	BACnetEventTransitionBits	-	O	R*
Acked_Transitions	BACnetEventTransitionBits	-	O	R*
Notify_Type	BACnetNotifyType	-	O	R*
Event_Time_Stamps	BACnetArray[N] of BACnetTimeStamp	-	O	R*
Event_Message_Texts	BACnetArray[3] of CharacterString	-	O	-
Event_Message_Texts_Config	BACnetArray[3] of CharacterString	-	O	-
Event_Detection_Enable	BOOLEAN	-	O	R*
Event_Algorithm_Inhibit_Ref	BACnetObjectPropertyReference	-	O	-
Event_Algorithm_Inhibit	BOOLEAN	-	O	-

Time_Delay_Normal	Unsigned	-	O	-
Reliability_Evaluation_Inhibit	BOOLEAN	-	O	-
Property_List	BACnetArray[N] of BACnetPropertyIdentifier	BACnetArray[N]	R	R
Profile_Name	CharacterString	-	O	-

* Only available when specific object has a Notification Class configured.

5.3.19 IU_rr_uu_SetTemp_Setting (Analog Output Object Type)

Set temperature can be commanded for indoor unit.

Property Identifier	Property Datatype	Value	ASHRAE	UTY-VBGX
Object_Identifier	BACnetObjectIdentifier	(Analog Output, 10rruu)	R	R
Object_Name	CharacterString	"IU_rr_uu_SetTemp_Setting"	R	R
Object_Type	BACnetObjectType	ANALOG_OUTPUT (1)	R	R
Present_Value	REAL	10 ~ 30(°C) // 48 ~ 88(°F)	W	W
Description	CharacterString	-	O	-
Device_Type	CharacterString	-	O	-
Status_Flags	BACnetStatusFlags	{FALSE, FALSE, FALSE, FALSE}	R	R
Event_State	BACnetEventState	STATE_NORMAL (0)	R	R
Reliability	BACnetReliability	NO_FAULT_DETECTED (0)	O	R
Out_Of_Service	BOOLEAN	FALSE	R	R
Update_Interval	Unsigned	-	O	-
Units	BACnetEngineeringUnits	Degrees Celsius (62) // Fahrenheit (64)	R	R
Min_Pres_Value	REAL	-	O	-
Max_Pres_Value	REAL	-	O	-
Resolution	REAL	-	O	-
COV_Increment	REAL	0	O	R
Priority_Array	BACnetPriorityArray	BACnetPriorityArray	R	R
Relinquish_Default	Unsigned	26	R	R
Time_Delay	Unsigned	-	O	R*
Notification_Class	Unsigned	-	O	R*
High_Limit	REAL	-	O	R*
Low_Limit	REAL	-	O	R*
Deadband	REAL	-	O	R*
Limit_Enable	BACnetLimitEnable	-	O	R*
Event_Enable	BACnetEventTransitionBits	-	O	R*
Acked_Transitions	BACnetEventTransitionBits	-	O	R*
Notify_Type	BACnetNotifyType	-	O	R*
Event_Time_Stamps	BACnetArray[N] of BACnetTimeStamp	-	O	R*
Event_Message_Texts	BACnetArray[3] of CharacterString	-	O	-
Event_Message_Texts_Config	BACnetArray[3] of CharacterString	-	O	-
Event_Detection_Enable	BOOLEAN	-	O	R*

Event_Algorithm_Inhibit_Ref	BACnetObjectPropertyReference	-	O	-
Event_Algorithm_Inhibit	BOOLEAN	-	O	-
Time_Delay_Normal	Unsigned	-	O	-
Reliability_Evaluation_Inhibit	BOOLEAN	-	O	-
Property_List	BACnetArray[N] of BACnetPropertyIdentifier	BACnetArray[N]	R	R
Profile_Name	CharacterString	-	O	-

* Only available when specific object has a Notification Class configured

Notes on the set temperature value

A set point value sent from the BMS must be taken from the column in the following table, whichever unit, Centigrade/Fahrenheit is used. Any entered values not from the table will be ignored, rounded or translated to other values.

A. Single split System (eg. Halcyon System) through the single network convertor

Cool/Dry/Auto : 18-30degC (64-88 degF)

Heat : 16-30 degC (60-88 degF)

Setting the value exceeding the upper or lower limit of the unit will be rounded to the nearest limit.

Fahrenheit	Centigrade	Fahrenheit	Centigrade
60	16	64	18
62	17	66	19
		68	20
		70	21
		72	22
		74	23
		76	24
		78	25
		80	26
		82	27
		84	28
		86	29
		88	30

B. Airstage VRF System

Setting the value exceeding the upper or lower value limit of the unit will be rounded to the nearest limit.

V-II or later Series: Value obtained by scanning

Fahrenheit	Centigrade	Fahrenheit	Centigrade
48	10	64	18
49	10.5	65	18.5
50	11	66	19
51	11.5	67	19.5
52	12	68	20
53	12.5	69	20.5
54	13	70	21
55	13.5	71	21.5
56	14	72	22
57	14.5	73	22.5
58	15	74	23
59	15.5	75	23.5
60	16	76	24
61	16.5	77	24.5
62	17	78	25
63	17.5	79	25.5
		80	26
		81	26.5
		82	27
		83	27.5
		84	28
		85	28.5
		86	29
		87	29.5
		88	30

5.3.20 IU_rr_uu_AutoTempLoLim_Setting (Analog Output Object Type)

Set temperature lower limit values when Auto Mode is active can be commanded for indoor unit.

Property Identifier	Property Datatype	Value	ASHRAE	UTY-VBGX
Object_Identifier	BACnetObjectIdentifier	(Analog Output, 11rruu)	R	R
Object_Name	CharacterString	"IU_rr_uu_AutoTempLoLim_Setting"	R	R
Object_Type	BACnetObjectType	ANALOG_OUTPUT (1)	R	R
Present_Value	REAL	18 ~ 30(°C) // 64 ~ 88(°F)	W	W
Description	CharacterString	-	O	-
Device_Type	CharacterString	-	O	-
Status_Flags	BACnetStatusFlags	{FALSE, FALSE, FALSE, FALSE}	R	R
Event_State	BACnetEventState	STATE_NORMAL (0)	R	R
Reliability	BACnetReliability	NO_FAULT_DETECTED (0)	O	R
Out_Of_Service	BOOLEAN	FALSE	R	R
Update_Interval	Unsigned	-	O	-
Units	BACnetEngineeringUnits	Degrees Celsius (62) // Fahrenheit (64)	R	R
Min_Pres_Value	REAL	-	O	-
Max_Pres_Value	REAL	-	O	-
Resolution	REAL	-	O	-
COV_Increment	REAL	0	O	R
Priority_Array	BACnetPriorityArray	BACnetPriorityArray	R	R
Relinquish_Default	Unsigned	26	R	R
Time_Delay	Unsigned	-	O	R*
Notification_Class	Unsigned	-	O	R*
High_Limit	REAL	-	O	R*
Low_Limit	REAL	-	O	R*
Deadband	REAL	-	O	R*
Limit_Enable	BACnetLimitEnable	-	O	R*
Event_Enable	BACnetEventTransitionBits	-	O	R*
Acked_Transitions	BACnetEventTransitionBits	-	O	R*
Notify_Type	BACnetNotifyType	-	O	R*
Event_Time_Stamps	BACnetArray[N] of BACnetTimeStamp	-	O	R*
Event_Message_Texts	BACnetArray[3] of CharacterString	-	O	-
Event_Message_Texts_Config	BACnetArray[3] of CharacterString	-	O	-
Event_Detection_Enable	BOOLEAN	-	O	R*

Event_Algorithm_Inhibit_Ref	BACnetObjectPropertyReference	-	O	-
Event_Algorithm_Inhibit	BOOLEAN	-	O	-
Time_Delay_Normal	Unsigned	-	O	-
Reliability_Evaluation_Inhibit	BOOLEAN	-	O	-
Property_List	BACnetArray[N] of BACnetPropertyIdentifier	BACnetArray[N]	R	R
Profile_Name	CharacterString	-	O	-

* Only available when specific object has a Notification Class configured

5.3.21 IU_rr_uu_AutoTempHiLim_Setting (Analog Output Object Type)

Set temperature upper limit values when Auto Mode is active can be commanded for indoor unit.

Property Identifier	Property Datatype	Value	ASHRAE	UTY-VBGX
Object_Identifier	BACnetObjectIdentifier	(Analog Output, 12rruu)	R	R
Object_Name	CharacterString	"IU_rr_uu_AutoTempHiLim_Setting"	R	R
Object_Type	BACnetObjectType	ANALOG_OUTPUT (1)	R	R
Present_Value	REAL	18 ~ 30(°C) // 64 ~ 88(°F)	W	W
Description	CharacterString	-	O	-
Device_Type	CharacterString	-	O	-
Status_Flags	BACnetStatusFlags	{FALSE, FALSE, FALSE, FALSE}	R	R
Event_State	BACnetEventState	STATE_NORMAL (0)	R	R
Reliability	BACnetReliability	NO_FAULT_DETECTED (0)	O	R
Out_Of_Service	BOOLEAN	FALSE	R	R
Update_Interval	Unsigned	-	O	-
Units	BACnetEngineeringUnits	Degrees Celsius (62) // Fahrenheit (64)	R	R
Min_Pres_Value	REAL	-	O	-
Max_Pres_Value	REAL	-	O	-
Resolution	REAL	-	O	-
COV_Increment	REAL	0	O	R
Priority_Array	BACnetPriorityArray	BACnetPriorityArray	R	R
Relinquish_Default	Unsigned	26	R	R
Time_Delay	Unsigned	-	O	R*
Notification_Class	Unsigned	-	O	R*
High_Limit	REAL	-	O	R*
Low_Limit	REAL	-	O	R*
Deadband	REAL	-	O	R*
Limit_Enable	BACnetLimitEnable	-	O	R*
Event_Enable	BACnetEventTransitionBits	-	O	R*
Acked_Transitions	BACnetEventTransitionBits	-	O	R*
Notify_Type	BACnetNotifyType	-	O	R*
Event_Time_Stamps	BACnetArray[N] of BACnetTimeStamp	-	O	R*
Event_Message_Texts	BACnetArray[3] of CharacterString	-	O	-
Event_Message_Texts_Config	BACnetArray[3] of CharacterString	-	O	-
Event_Detection_Enable	BOOLEAN	-	O	R*

Event_Algorithm_Inhibit_Ref	BACnetObjectPropertyReference	-	O	-
Event_Algorithm_Inhibit	BOOLEAN	-	O	-
Time_Delay_Normal	Unsigned	-	O	-
Reliability_Evaluation_Inhibit	BOOLEAN	-	O	-
Property_List	BACnetArray[N] of BACnetPropertyIdentifier	BACnetArray[N]	R	R
Profile_Name	CharacterString	-	O	-

* Only available when specific object has a Notification Class configured

5.3.22 IU_rr_uu_CoolTempLoLim_Setting (Analog Output Object Type)

Set temperature lower limit values when Cool Mode is active can be commanded for indoor unit.

Property Identifier	Property Datatype	Value	ASHRAE	UTY-VBGX
Object_Identifier	BACnetObjectIdentifier	(Analog Output, 13rruu)	R	R
Object_Name	CharacterString	"IU_rr_uu_CoolTempLoLim_Setting"	R	R
Object_Type	BACnetObjectType	ANALOG_OUTPUT (1)	R	R
Present_Value	REAL	18 ~ 30(°C) // 64 ~ 88(°F)	W	W
Description	CharacterString	-	O	-
Device_Type	CharacterString	-	O	-
Status_Flags	BACnetStatusFlags	{FALSE, FALSE, FALSE, FALSE}	R	R
Event_State	BACnetEventState	STATE_NORMAL (0)	R	R
Reliability	BACnetReliability	NO_FAULT_DETECTED (0)	O	R
Out_Of_Service	BOOLEAN	FALSE	R	R
Update_Interval	Unsigned	-	O	-
Units	BACnetEngineeringUnits	Degrees Celsius (62) // Fahrenheit (64)	R	R
Min_Pres_Value	REAL	-	O	-
Max_Pres_Value	REAL	-	O	-
Resolution	REAL	-	O	-
COV_Increment	REAL	0	O	R
Priority_Array	BACnetPriorityArray	BACnetPriorityArray	R	R
Relinquish_Default	Unsigned	26	R	R
Time_Delay	Unsigned	-	O	R*
Notification_Class	Unsigned	-	O	R*
High_Limit	REAL	-	O	R*
Low_Limit	REAL	-	O	R*
Deadband	REAL	-	O	R*
Limit_Enable	BACnetLimitEnable	-	O	R*
Event_Enable	BACnetEventTransitionBits	-	O	R*
Acked_Transitions	BACnetEventTransitionBits	-	O	R*
Notify_Type	BACnetNotifyType	-	O	R*
Event_Time_Stamps	BACnetArray[N] of BACnetTimeStamp	-	O	R*
Event_Message_Texts	BACnetArray[3] of CharacterString	-	O	-
Event_Message_Texts_Config	BACnetArray[3] of CharacterString	-	O	-
Event_Detection_Enable	BOOLEAN	-	O	R*

Event_Algorithm_Inhibit_Ref	BACnetObjectPropertyReference	-	O	-
Event_Algorithm_Inhibit	BOOLEAN	-	O	-
Time_Delay_Normal	Unsigned	-	O	-
Reliability_Evaluation_Inhibit	BOOLEAN	-	O	-
Property_List	BACnetArray[N] of BACnetPropertyIdentifier	BACnetArray[N]	R	R
Profile_Name	CharacterString	-	O	-

* Only available when specific object has a Notification Class configured.

5.3.23 IU_rr_uu_CoolTempHiLim_Setting (Analog Output Object Type)

Set temperature upper limit values when Cool Mode is active can be commanded for indoor unit.

Property Identifier	Property Datatype	Value	ASHRAE	UTY-VBGX
Object_Identifier	BACnetObjectIdentifier	(Analog Output, 14rruu)	R	R
Object_Name	CharacterString	"IU_rr_uu_CoolTempHiLim_Setting"	R	R
Object_Type	BACnetObjectType	ANALOG_OUTPUT (1)	R	R
Present_Value	REAL	18~ 30(°C) // 64 ~ 88(°F)	W	W
Description	CharacterString	-	O	-
Device_Type	CharacterString	-	O	-
Status_Flags	BACnetStatusFlags	{FALSE, FALSE, FALSE, FALSE}	R	R
Event_State	BACnetEventState	STATE_NORMAL (0)	R	R
Reliability	BACnetReliability	NO_FAULT_DETECTED (0)	O	R
Out_Of_Service	BOOLEAN	FALSE	R	R
Update_Interval	Unsigned	-	O	-
Units	BACnetEngineeringUnits	Degrees Celsius (62) // Fahrenheit (64)	R	R
Min_Pres_Value	REAL	-	O	-
Max_Pres_Value	REAL	-	O	-
Resolution	REAL	-	O	-
COV_Increment	REAL	0	O	R
Priority_Array	BACnetPriorityArray	BACnetPriorityArray	R	R
Relinquish_Default	Unsigned	26	R	R
Time_Delay	Unsigned	-	O	R*
Notification_Class	Unsigned	-	O	R*
High_Limit	REAL	-	O	R*
Low_Limit	REAL	-	O	R*
Deadband	REAL	-	O	R*
Limit_Enable	BACnetLimitEnable	-	O	R*
Event_Enable	BACnetEventTransitionBits	-	O	R*
Acked_Transitions	BACnetEventTransitionBits	-	O	R*
Notify_Type	BACnetNotifyType	-	O	R*
Event_Time_Stamps	BACnetArray[N] of BACnetTimeStamp	-	O	R*
Event_Message_Texts	BACnetArray[3] of CharacterString	-	O	-
Event_Message_Texts_Config	BACnetArray[3] of CharacterString	-	O	-
Event_Detection_Enable	BOOLEAN	-	O	R*

Event_Algorithm_Inhibit_Ref	BACnetObjectPropertyReference	-	O	-
Event_Algorithm_Inhibit	BOOLEAN	-	O	-
Time_Delay_Normal	Unsigned	-	O	-
Reliability_Evaluation_Inhibit	BOOLEAN	-	O	-
Property_List	BACnetArray[N] of BACnetPropertyIdentifier	BACnetArray[N]	R	R
Profile_Name	CharacterString	-	O	-

* Only available when specific object has a Notification Class configured

5.3.24 IU_rr_uu_HeatTempLoLim_Setting (Analog Output Object Type)

Set temperature lower limit values when Heat Mode is active can be commanded for indoor unit.

Property Identifier	Property Datatype	Value	ASHRAE	UTY-VBGX
Object_Identifier	BACnetObjectIdentifier	(Analog Output, 15rruu)	R	R
Object_Name	CharacterString	"IU_rr_uu_HeatTempLoLim_Setting"	R	R
Object_Type	BACnetObjectType	ANALOG_OUTPUT (1)	R	R
Present_Value	REAL	10 ~ 30(°C) // 48 ~ 88(°F)	W	W
Description	CharacterString	-	O	-
Device_Type	CharacterString	-	O	-
Status_Flags	BACnetStatusFlags	{FALSE, FALSE, FALSE, FALSE}	R	R
Event_State	BACnetEventState	STATE_NORMAL (0)	R	R
Reliability	BACnetReliability	NO_FAULT_DETECTED (0)	O	R
Out_Of_Service	BOOLEAN	FALSE	R	R
Update_Interval	Unsigned	-	O	-
Units	BACnetEngineeringUnits	Degrees Celsius (62) // Fahrenheit (64)	R	R
Min_Pres_Value	REAL	-	O	-
Max_Pres_Value	REAL	-	O	-
Resolution	REAL	-	O	-
COV_Increment	REAL	0	O	R
Priority_Array	BACnetPriorityArray	BACnetPriorityArray	R	R
Relinquish_Default	Unsigned	26	R	R
Time_Delay	Unsigned	-	O	R*
Notification_Class	Unsigned	-	O	R*
High_Limit	REAL	-	O	R*
Low_Limit	REAL	-	O	R*
Deadband	REAL	-	O	R*
Limit_Enable	BACnetLimitEnable	-	O	R*
Event_Enable	BACnetEventTransitionBits	-	O	R*
Acked_Transitions	BACnetEventTransitionBits	-	O	R*
Notify_Type	BACnetNotifyType	-	O	R*
Event_Time_Stamps	BACnetArray[N] of BACnetTimeStamp	-	O	R*
Event_Message_Texts	BACnetArray[3] of CharacterString	-	O	-
Event_Message_Texts_Config	BACnetArray[3] of CharacterString	-	O	-
Event_Detection_Enable	BOOLEAN	-	O	R*

Event_Algorithm_Inhibit_Ref	BACnetObjectPropertyReference	-	O	-
Event_Algorithm_Inhibit	BOOLEAN	-	O	-
Time_Delay_Normal	Unsigned	-	O	-
Reliability_Evaluation_Inhibit	BOOLEAN	-	O	-
Property_List	BACnetArray[N] of BACnetPropertyIdentifier	BACnetArray[N]	R	R
Profile_Name	CharacterString	-	O	-

* Only available when specific object has a Notification Class configured

5.3.25 IU_rr_uu_HeatTempHiLim_Setting (Analog Output Object Type)

Set temperature upper limit values when Heat Mode is active can be commanded for indoor unit.

Property Identifier	Property Datatype	Value	ASHRAE	UTY-VBGX
Object_Identifier	BACnetObjectIdentifier	(Analog Output, 16rruu)	R	R
Object_Name	CharacterString	"IU_rr_uu_HeatTempHiLim_Setting"	R	R
Object_Type	BACnetObjectType	ANALOG_OUTPUT (1)	R	R
Present_Value	REAL	10 ~ 30(°C) // 48 ~ 88(°F)	W	W
Description	CharacterString	-	O	-
Device_Type	CharacterString	-	O	-
Status_Flags	BACnetStatusFlags	{FALSE, FALSE, FALSE, FALSE}	R	R
Event_State	BACnetEventState	STATE_NORMAL (0)	R	R
Reliability	BACnetReliability	NO_FAULT_DETECTED (0)	O	R
Out_Of_Service	BOOLEAN	FALSE	R	R
Update_Interval	Unsigned	-	O	-
Units	BACnetEngineeringUnits	Degrees Celsius (62) // Fahrenheit (64)	R	R
Min_Pres_Value	REAL	-	O	-
Max_Pres_Value	REAL	-	O	-
Resolution	REAL	-	O	-
COV_Increment	REAL	0	O	R
Priority_Array	BACnetPriorityArray	BACnetPriorityArray	R	R
Relinquish_Default	Unsigned	26	R	R
Time_Delay	Unsigned	-	O	R*
Notification_Class	Unsigned	-	O	R*
High_Limit	REAL	-	O	R*
Low_Limit	REAL	-	O	R*
Deadband	REAL	-	O	R*
Limit_Enable	BACnetLimitEnable	-	O	R*
Event_Enable	BACnetEventTransitionBits	-	O	R*
Acked_Transitions	BACnetEventTransitionBits	-	O	R*
Notify_Type	BACnetNotifyType	-	O	R*
Event_Time_Stamps	BACnetArray[N] of BACnetTimeStamp	-	O	R*
Event_Message_Texts	BACnetArray[3] of CharacterString	-	O	-
Event_Message_Texts_Config	BACnetArray[3] of CharacterString	-	O	-
Event_Detection_Enable	BOOLEAN	-	O	R*

Event_Algorithm_Inhibit_Ref	BACnetObjectPropertyReference	-	O	-
Event_Algorithm_Inhibit	BOOLEAN	-	O	-
Time_Delay_Normal	Unsigned	-	O	-
Reliability_Evaluation_Inhibit	BOOLEAN	-	O	-
Property_List	BACnetArray[N] of BACnetPropertyIdentifier	BACnetArray[N]	R	R
Profile_Name	CharacterString	-	O	-

* Only available when specific object has a Notification Class configured

5.3.26 IU_rr_uu_Exists_Status (Binary Input Object Type)

Check the presence of the specified indoor units in the AC system.

Property Identifier	Property Datatype	Value	ASHRAE	UTY-VBGX
Object_Identifier	BACnetObjectIdentifier	(Binary Input, 10rruu)	R	R
Object_Name	CharacterString	"IU_rr_uu_Exists_Status"	R	R
Object_Type	BACnetObjectType	BINARY_INPUT (3)	R	R
Present_Value	BACnetBinaryPV	INACTIVE (0) / ACTIVE (1)	R	R
Description	CharacterString	-	O	-
Device_Type	CharacterString	-	O	-
Status_Flags	BACnetStatusFlags	{FALSE, FALSE/TRUE, FALSE, FALSE}	R	R
Event_State	BACnetEventState	STATE_NORMAL (0)	R	R
Reliability	BACnetReliability	NO_FAULT_DETECTED (0), UNRELIABLE_OTHER (7)	O	R
Out_Of_Service	BOOLEAN	FALSE	R	R
Polarity	BACnetPolarity	NORMAL (0)	R	R
Inactive_Text	CharacterString	"Not Exists"	O	R
Active_Text	CharacterString	"Exists"	O	R
Change_Of_State_Time	BACnetDatetime	-	O	-
Change_Of_State_Count	Unsigned	-	O	-
Time_Of_State_Count_Reset	BACnetDatetime	-	O	-
Elapsed_Active_Time	Unsigned	-	O	-
Time_Of_Active_Time_Reset	BACnetDatetime	-	O	-
Time_Delay	Unsigned	-	O	R*
Notification_Class	Unsigned	-	O	R*
Alarm_Value	BACnetBinaryPV	-	O	R*
Event_Enable	BACnetEventTransitionBits	-	O	R*
Acked_Transitions	BACnetEventTransitionBits	-	O	R*
Notify_Type	BACnetNotifyType	-	O	R*
Event_Time_Stamps	BACnetArray[N] of BACnetTimeStamp	-	O	R*
Event_Message_Texts	BACnetArray[3] of CharacterString	-	O	-
Event_Message_Texts_Config	BACnetArray[3] of CharacterString	-	O	-
Event_Detection_Enable	BOOLEAN	-	O	R*
Event_Algorithm_Inhibit_Ref	BACnetObjectPropertyReference	-	O	-
Event_Algorithm_Inhibit	BOOLEAN	-	O	-
Time_Delay_Normal	Unsigned	-	O	-

Reliability_Evaluation_Inhibit	BOOLEAN	-	O	-
Property_List	BACnetArray[N] of BACnetPropertyIdentifier	BACnetArray[N]	R	R
Profile_Name	CharacterString	-	O	-

* Only available when specific object has a Notification Class configured

5.3.27 IU_rr_uu_Operation_Status (Binary Input Object Type)

Indoor unit operation ON/OFF setting status can be monitored.

Property Identifier	Property Datatype	Value	ASHRAE	UTY-VBGX
Object_Identifier	BACnetObjectIdentifier	(Binary Input, 11rruu)	R	R
Object_Name	CharacterString	"IU_rr_uu_Operation_Status"	R	R
Object_Type	BACnetObjectType	BINARY_INPUT (3)	R	R
Present_Value	BACnetBinaryPV	INACTIVE (0) / ACTIVE (1)	R	R
Description	CharacterString	-	O	-
Device_Type	CharacterString	-	O	-
Status_Flags	BACnetStatusFlags	{FALSE, FALSE/TRUE, FALSE, FALSE}	R	R
Event_State	BACnetEventState	STATE_NORMAL (0)	R	R
Reliability	BACnetReliability	NO_FAULT_DETECTED (0), UNRELIABLE_OTHER (7)	O	R
Out_Of_Service	BOOLEAN	FALSE	R	R
Polarity	BACnetPolarity	NORMAL (0)	R	R
Inactive_Text	CharacterString	"Off"	O	R
Active_Text	CharacterString	"On"	O	R
Change_Of_State_Time	BACnetDatetime	-	O	-
Change_Of_State_Count	Unsigned	-	O	-
Time_Of_State_Count_Reset	BACnetDatetime	-	O	-
Elapsed_Active_Time	Unsigned	-	O	-
Time_Of_Active_Time_Reset	BACnetDatetime	-	O	-
Time_Delay	Unsigned	-	O	R*
Notification_Class	Unsigned	-	O	R*
Alarm_Value	BACnetBinaryPV	-	O	R*
Event_Enable	BACnetEventTransitionBits	-	O	R*
Acked_Transitions	BACnetEventTransitionBits	-	O	R*
Notify_Type	BACnetNotifyType	-	O	R*
Event_Time_Stamps	BACnetArray[N] of BACnetTimeStamp	-	O	R*
Event_Message_Texts	BACnetArray[3] of CharacterString	-	O	-
Event_Message_Texts_Config	BACnetArray[3] of CharacterString	-	O	-
Event_Detection_Enable	BOOLEAN	-	O	R*
Event_Algorithm_Inhibit_Ref	BACnetObjectPropertyReference	-	O	-
Event_Algorithm_Inhibit	BOOLEAN	-	O	-
Time_Delay_Normal	Unsigned	-	O	-

Reliability_Evaluation_Inhibit	BOOLEAN	-	O	-
Property_List	BACnetArray[N] of BACnetPropertyIdentifier	BACnetArray[N]	R	R
Profile_Name	CharacterString	-	O	-

* Only available when specific object has a Notification Class configured

5.3.28 IU_rr_uu_ThermostatOFF_Status (Binary Input Object Type)

Indoor unit forced thermostat OFF setting status can be monitored

Property Identifier	Property Datatype	Value	ASHRAE	UTY-VBGX
Object_Identifier	BACnetObjectIdentifier	(Binary Input, 12rruu)	R	R
Object_Name	CharacterString	"IU_rr_uu_ThermostatOFF_Status"	R	R
Object_Type	BACnetObjectType	BINARY_INPUT (3)	R	R
Present_Value	BACnetBinaryPV	INACTIVE (0) / ACTIVE (1)	R	R
Description	CharacterString	-	O	-
Device_Type	CharacterString	-	O	-
Status_Flags	BACnetStatusFlags	{FALSE, FALSE/TRUE, FALSE, FALSE}	R	R
Event_State	BACnetEventState	STATE_NORMAL (0)	R	R
Reliability	BACnetReliability	NO_FAULT_DETECTED (0), UNRELIABLE_OTHER (7)	O	R
Out_Of_Service	BOOLEAN	FALSE	R	R
Polarity	BACnetPolarity	NORMAL (0)	R	R
Inactive_Text	CharacterString	"Reset"	O	R
Active_Text	CharacterString	"Set"	O	R
Change_Of_State_Time	BACnetDatetime	-	O	-
Change_Of_State_Count	Unsigned	-	O	-
Time_Of_State_Count_Reset	BACnetDatetime	-	O	-
Elapsed_Active_Time	Unsigned	-	O	-
Time_Of_Active_Time_Reset	BACnetDatetime	-	O	-
Time_Delay	Unsigned	-	O	R*
Notification_Class	Unsigned	-	O	R*
Alarm_Value	BACnetBinaryPV	-	O	R*
Event_Enable	BACnetEventTransitionBits	-	O	R*
Acked_Transitions	BACnetEventTransitionBits	-	O	R*
Notify_Type	BACnetNotifyType	-	O	R*
Event_Time_Stamps	BACnetArray[N] of BACnetTimeStamp	-	O	R*
Event_Message_Texts	BACnetArray[3] of CharacterString	-	O	-
Event_Message_Texts_Config	BACnetArray[3] of CharacterString	-	O	-
Event_Detection_Enable	BOOLEAN	-	O	R*
Event_Algorithm_Inhibit_Ref	BACnetObjectPropertyReference	-	O	-
Event_Algorithm_Inhibit	BOOLEAN	-	O	-
Time_Delay_Normal	Unsigned	-	O	-

Reliability_Evaluation_Inhibit	BOOLEAN	-	O	-
Property_List	BACnetArray[N] of BACnetPropertyIdentifier	BACnetArray[N]	R	R
Profile_Name	CharacterString	-	O	-

* Only available when specific object has a Notification Class configured

5.3.29 IU_rr_uu_FilterSign_Status (Binary Input Object Type)

Indoor unit filter sign status can be monitored.

Property Identifier	Property Datatype	Value	ASHRAE	UTY-VBGX
Object_Identifier	BACnetObjectIdentifier	(Binary Input, 13rruu)	R	R
Object_Name	CharacterString	"IU_rr_uu_FilterSign_Status"	R	R
Object_Type	BACnetObjectType	BINARY_INPUT (3)	R	R
Present_Value	BACnetBinaryPV	INACTIVE (0) / ACTIVE (1)	R	R
Description	CharacterString	-	O	-
Device_Type	CharacterString	-	O	-
Status_Flags	BACnetStatusFlags	{FALSE, FALSE/TRUE, FALSE, FALSE}	R	R
Event_State	BACnetEventState	STATE_NORMAL (0)	R	R
Reliability	BACnetReliability	NO_FAULT_DETECTED (0), UNRELIABLE_OTHER (7)	O	R
Out_Of_Service	BOOLEAN	FALSE	R	R
Polarity	BACnetPolarity	NORMAL (0)	R	R
Inactive_Text	CharacterString	"Unsigned"	O	R
Active_Text	CharacterString	"Signed"	O	R
Change_Of_State_Time	BACnetDatetime	-	O	-
Change_Of_State_Count	Unsigned	-	O	-
Time_Of_State_Count_Reset	BACnetDatetime	-	O	-
Elapsed_Active_Time	Unsigned	-	O	-
Time_Of_Active_Time_Reset	BACnetDatetime	-	O	-
Time_Delay	Unsigned	-	O	R*
Notification_Class	Unsigned	-	O	R*
Alarm_Value	BACnetBinaryPV	-	O	R*
Event_Enable	BACnetEventTransitionBits	-	O	R*
Acked_Transitions	BACnetEventTransitionBits	-	O	R*
Notify_Type	BACnetNotifyType	-	O	R*
Event_Time_Stamps	BACnetArray[N] of BACnetTimeStamp	-	O	R*
Event_Message_Texts	BACnetArray[3] of CharacterString	-	O	-
Event_Message_Texts_Config	BACnetArray[3] of CharacterString	-	O	-
Event_Detection_Enable	BOOLEAN	-	O	R*
Event_Algorithm_Inhibit_Ref	BACnetObjectPropertyReference	-	O	-
Event_Algorithm_Inhibit	BOOLEAN	-	O	-
Time_Delay_Normal	Unsigned	-	O	-

Reliability_Evaluation_Inhibit	BOOLEAN	-	O	-
Property_List	BACnetArray[N] of BACnetPropertyIdentifier	BACnetArray[N]	R	R
Profile_Name	CharacterString	-	O	-

* Only available when specific object has a Notification Class configured

5.3.30 IU_rr_uu_Emergency_Status (Binary Input Object Type)

Indoor unit emergency stop operation status can be monitored.

Property Identifier	Property Datatype	Value	ASHRAE	UTY-VBGX
Object_Identifier	BACnetObjectIdentifier	(Binary Input, 14rruu)	R	R
Object_Name	CharacterString	"IU_rr_uu_Emergency_Status"	R	R
Object_Type	BACnetObjectType	BINARY_INPUT (3)	R	R
Present_Value	BACnetBinaryPV	INACTIVE (0) / ACTIVE (1)	R	R
Description	CharacterString	-	O	-
Device_Type	CharacterString	-	O	-
Status_Flags	BACnetStatusFlags	{FALSE, FALSE/TRUE, FALSE, FALSE}	R	R
Event_State	BACnetEventState	STATE_NORMAL (0)	R	R
Reliability	BACnetReliability	NO_FAULT_DETECTED (0), UNRELIABLE_OTHER (7)	O	R
Out_Of_Service	BOOLEAN	FALSE	R	R
Polarity	BACnetPolarity	NORMAL (0)	R	R
Inactive_Text	CharacterString	"Normal"	O	R
Active_Text	CharacterString	"Stop"	O	R
Change_Of_State_Time	BACnetDatetime	-	O	-
Change_Of_State_Count	Unsigned	-	O	-
Time_Of_State_Count_Reset	BACnetDatetime	-	O	-
Elapsed_Active_Time	Unsigned	-	O	-
Time_Of_Active_Time_Reset	BACnetDatetime	-	O	-
Time_Delay	Unsigned	-	O	R*
Notification_Class	Unsigned	-	O	R*
Alarm_Value	BACnetBinaryPV	-	O	R*
Event_Enable	BACnetEventTransitionBits	-	O	R*
Acked_Transitions	BACnetEventTransitionBits	-	O	R*
Notify_Type	BACnetNotifyType	-	O	R*
Event_Time_Stamps	BACnetArray[N] of BACnetTimeStamp	-	O	R*
Event_Message_Texts	BACnetArray[3] of CharacterString	-	O	-
Event_Message_Texts_Config	BACnetArray[3] of CharacterString	-	O	-
Event_Detection_Enable	BOOLEAN	-	O	R*
Event_Algorithm_Inhibit_Ref	BACnetObjectPropertyReference	-	O	-
Event_Algorithm_Inhibit	BOOLEAN	-	O	-
Time_Delay_Normal	Unsigned	-	O	-

Reliability_Evaluation_Inhibit	BOOLEAN	-	O	-
Property_List	BACnetArray[N] of BACnetPropertyIdentifier	BACnetArray[N]	R	R
Profile_Name	CharacterString	-	O	-

* Only available when specific object has a Notification Class configured

5.3.31 IU_rr_uu_Error_Status (Binary Input Object Type)

The normal and error statuses of indoor unit can be monitored.

Property Identifier	Property Datatype	Value	ASHRAE	UTY-VBGX
Object_Identifier	BACnetObjectIdentifier	(Binary Input, 15rruu)	R	R
Object_Name	CharacterString	"IU_rr_uu_Error_Status"	R	R
Object_Type	BACnetObjectType	BINARY_INPUT (3)	R	R
Present_Value	BACnetBinaryPV	INACTIVE (0) / ACTIVE (1)	R	R
Description	CharacterString	-	O	-
Device_Type	CharacterString	-	O	-
Status_Flags	BACnetStatusFlags	{FALSE, FALSE/TRUE, FALSE, FALSE}	R	R
Event_State	BACnetEventState	STATE_NORMAL (0)	R	R
Reliability	BACnetReliability	NO_FAULT_DETECTED (0), UNRELIABLE_OTHER (7)	O	R
Out_Of_Service	BOOLEAN	FALSE	R	R
Polarity	BACnetPolarity	NORMAL (0)	R	R
Inactive_Text	CharacterString	"Normal"	O	R
Active_Text	CharacterString	"Fault"	O	R
Change_Of_State_Time	BACnetDatetime	-	O	-
Change_Of_State_Count	Unsigned	-	O	-
Time_Of_State_Count_Reset	BACnetDatetime	-	O	-
Elapsed_Active_Time	Unsigned	-	O	-
Time_Of_Active_Time_Reset	BACnetDatetime	-	O	-
Time_Delay	Unsigned	-	O	R*
Notification_Class	Unsigned	-	O	R*
Alarm_Value	BACnetBinaryPV	-	O	R*
Event_Enable	BACnetEventTransitionBits	-	O	R*
Acked_Transitions	BACnetEventTransitionBits	-	O	R*
Notify_Type	BACnetNotifyType	-	O	R*
Event_Time_Stamps	BACnetArray[N] of BACnetTimeStamp	-	O	R*
Event_Message_Texts	BACnetArray[3] of CharacterString	-	O	-
Event_Message_Texts_Config	BACnetArray[3] of CharacterString	-	O	-
Event_Detection_Enable	BOOLEAN	-	O	R*
Event_Algorithm_Inhibit_Ref	BACnetObjectPropertyReference	-	O	-
Event_Algorithm_Inhibit	BOOLEAN	-	O	-
Time_Delay_Normal	Unsigned	-	O	-

Reliability_Evaluation_Inhibit	BOOLEAN	-	O	-
Property_List	BACnetArray[N] of BACnetPropertyIdentifier	BACnetArray[N]	R	R
Profile_Name	CharacterString	-	O	-

* Only available when specific object has a Notification Class configured

5.3.32 IU_rr_uu_TempLimValid_Status (Binary Input Object Type)

Indoor unit set temperature upper and lower limit values valid/invalid setting status can be monitored.

Property Identifier	Property Datatype	Value	ASHRAE	UTY-VBGX
Object_Identifier	BACnetObjectIdentifier	(Binary Input, 16rruu)	R	R
Object_Name	CharacterString	"IU_rr_uu_TempLimValid_Status"	R	R
Object_Type	BACnetObjectType	BINARY_INPUT (3)	R	R
Present_Value	BACnetBinaryPV	INACTIVE (0) / ACTIVE (1)	R	R
Description	CharacterString	-	O	-
Device_Type	CharacterString	-	O	-
Status_Flags	BACnetStatusFlags	{FALSE, FALSE/TRUE, FALSE, FALSE}	R	R
Event_State	BACnetEventState	STATE_NORMAL (0)	R	R
Reliability	BACnetReliability	NO_FAULT_DETECTED (0), UNRELIABLE_OTHER (7)	O	R
Out_Of_Service	BOOLEAN	FALSE	R	R
Polarity	BACnetPolarity	NORMAL (0)	R	R
Inactive_Text	CharacterString	"Invalid"	O	R
Active_Text	CharacterString	"Valid"	O	R
Change_Of_State_Time	BACnetDatetime	-	O	-
Change_Of_State_Count	Unsigned	-	O	-
Time_Of_State_Count_Reset	BACnetDatetime	-	O	-
Elapsed_Active_Time	Unsigned	-	O	-
Time_Of_Active_Time_Reset	BACnetDatetime	-	O	-
Time_Delay	Unsigned	-	O	R*
Notification_Class	Unsigned	-	O	R*
Alarm_Value	BACnetBinaryPV	-	O	R*
Event_Enable	BACnetEventTransitionBits	-	O	R*
Acked_Transitions	BACnetEventTransitionBits	-	O	R*
Notify_Type	BACnetNotifyType	-	O	R*
Event_Time_Stamps	BACnetArray[N] of BACnetTimeStamp	-	O	R*
Event_Message_Texts	BACnetArray[3] of CharacterString	-	O	-
Event_Message_Texts_Config	BACnetArray[3] of CharacterString	-	O	-
Event_Detection_Enable	BOOLEAN	-	O	R*
Event_Algorithm_Inhibit_Ref	BACnetObjectPropertyReference	-	O	-
Event_Algorithm_Inhibit	BOOLEAN	-	O	-
Time_Delay_Normal	Unsigned	-	O	-

Reliability_Evaluation_Inhibit	BOOLEAN	-	O	-
Property_List	BACnetArray[N] of BACnetPropertyIdentifier	BACnetArray[N]	R	R
Profile_Name	CharacterString	-	O	-

* Only available when specific object has a Notification Class configured

5.3.33 IU_rr_uu_Operation_Setting (Binary Output Object Type)

Operation ON/OFF can be commanded for indoor unit.

Property Identifier	Property Datatype	Value	ASHRAE	UTY-VBGX
Object_Identifier	BACnetObjectIdentifier	(Binary Output, 10rruu)	R	R
Object_Name	CharacterString	"IU_rr_uu_Operation_Setting"	R	R
Object_Type	BACnetObjectType	BINARY_OUTPUT (4)	R	R
Present_Value	BACnetBinaryPV	INACTIVE (0) / ACTIVE (1)	W	W
Description	CharacterString	-	O	-
Device_Type	CharacterString	-	O	-
Status_Flags	BACnetStatusFlags	{FALSE, FALSE, FALSE, FALSE}	R	R
Event_State	BACnetEventState	STATE_NORMAL (0)	R	R
Reliability	BACnetReliability	NO_FAULT_DETECTED (0)	O	R
Out_Of_Service	BOOLEAN	FALSE	R	R
Polarity	BACnetPolarity	NORMAL (0)	R	R
Inactive_Text	CharacterString	"Off"	O	R
Active_Text	CharacterString	"On"	O	R
Change_Of_State_Time	BACnetDatetime	-	O	-
Change_Of_State_Count	Unsigned	-	O	-
Time_Of_State_Count_Reset	BACnetDatetime	-	O	-
Elapsed_Active_Time	Unsigned	-	O	-
Time_Of_Active_Time_Reset	BACnetDatetime	-	O	-
Minimum_Off_Time	Unsigned32	-	O	-
Minimum_On_Time	Unsigned32	-	O	-
Priority_Array	BACnetPriorityArray	BACnetPriorityArray	R	R
Relinquish_Default	BACnetBinaryPV	INACTIVE (0)	R	R
Time_Delay	Unsigned	-	O	R*
Notification_Class	Unsigned	-	O	R*
Feedback_Value	BACnetBinaryPV	-	O	W
Event_Enable	BACnetEventTransitionBits	-	O	R*
Acked_Transitions	BACnetEventTransitionBits	-	O	R*
Notify_Type	BACnetNotifyType	-	O	R*
Event_Time_Stamps	BACnetArray[N] of BACnetTimeStamp	-	O	R*
Event_Message_Texts	BACnetArray[3] of CharacterString	-	O	-
Event_Message_Texts_Config	BACnetArray[3] of CharacterString	-	O	-

Event_Detection_Enable	BOOLEAN	-	O	R*
Event_Algorithm_Inhibit_Ref	BACnetObjectPropertyReference	-	O	-
Event_Algorithm_Inhibit	BOOLEAN	-	O	-
Time_Delay_Normal	Unsigned	-	O	-
Reliability_Evaluation_Inhibit	BOOLEAN	-	O	-
Property_List	BACnetArray[N] of BACnetPropertyIdentifier	BACnetArray[N]	R	R
Profile_Name	CharacterString	-	O	-

* Only available when specific object has a Notification Class configured

5.3.34 IU_rr_uu_ThermostatOFF_Setting (Binary Output Object Type)

Forced thermostat OFF operation setting can be commanded for indoor unit.

Property Identifier	Property Datatype	Value	ASHRAE	UTY-VBGX
Object_Identifier	BACnetObjectIdentifier	(Binary Output, 11rruu)	R	R
Object_Name	CharacterString	"IU_rr_uu_ThermostatOFF_Setting"	R	R
Object_Type	BACnetObjectType	BINARY_OUTPUT (4)	R	R
Present_Value	BACnetBinaryPV	INACTIVE (0) / ACTIVE (1)	W	W
Description	CharacterString	-	O	-
Device_Type	CharacterString	-	O	-
Status_Flags	BACnetStatusFlags	{FALSE, FALSE, FALSE, FALSE}	R	R
Event_State	BACnetEventState	STATE_NORMAL (0)	R	R
Reliability	BACnetReliability	NO_FAULT_DETECTED (0)	O	R
Out_Of_Service	BOOLEAN	FALSE	R	R
Polarity	BACnetPolarity	NORMAL (0)	R	R
Inactive_Text	CharacterString	"Reset"	O	R
Active_Text	CharacterString	"Set"	O	R
Change_Of_State_Time	BACnetDatetime	-	O	-
Change_Of_State_Count	Unsigned	-	O	-
Time_Of_State_Count_Reset	BACnetDatetime	-	O	-
Elapsed_Active_Time	Unsigned	-	O	-
Time_Of_Active_Time_Reset	BACnetDatetime	-	O	-
Minimum_Off_Time	Unsigned32	-	O	-
Minimum_On_Time	Unsigned32	-	O	-
Priority_Array	BACnetPriorityArray	BACnetPriorityArray	R	R
Relinquish_Default	BACnetBinaryPV	INACTIVE (0)	R	R
Time_Delay	Unsigned	-	O	R*
Notification_Class	Unsigned	-	O	R*
Feedback_Value	BACnetBinaryPV	-	O	W
Event_Enable	BACnetEventTransitionBits	-	O	R*
Acked_Transitions	BACnetEventTransitionBits	-	O	R*
Notify_Type	BACnetNotifyType	-	O	R*
Event_Time_Stamps	BACnetArray[N] of BACnetTimeStamp	-	O	R*
Event_Message_Texts	BACnetArray[3] of CharacterString	-	O	-
Event_Message_Texts_Config	BACnetArray[3] of CharacterString	-	O	-

Event_Detection_Enable	BOOLEAN	-	O	R*
Event_Algorithm_Inhibit_Ref	BACnetObjectPropertyReference	-	O	-
Event_Algorithm_Inhibit	BOOLEAN	-	O	-
Time_Delay_Normal	Unsigned	-	O	-
Reliability_Evaluation_Inhibit	BOOLEAN	-	O	-
Property_List	BACnetArray[N] of BACnetPropertyIdentifier	BACnetArray[N]	R	R
Profile_Name	CharacterString	-	O	-

* Only available when specific object has a Notification Class configured

5.3.35 IU_rr_uu_Reset_Filter_Setting (Binary Output Object Type)

Filter sign reset can be commanded for indoor unit.

Property Identifier	Property Datatype	Value	ASHRAE	UTY-VBGX
Object_Identifier	BACnetObjectIdentifier	(Binary Output, 12rruu)	R	R
Object_Name	CharacterString	"IU_rr_uu_Reset_Filter_Setting"	R	R
Object_Type	BACnetObjectType	BINARY_OUTPUT (4)	R	R
Present_Value	BACnetBinaryPV	INACTIVE (0) / ACTIVE (1)	W	W
Description	CharacterString	-	O	-
Device_Type	CharacterString	-	O	-
Status_Flags	BACnetStatusFlags	{FALSE, FALSE, FALSE, FALSE}	R	R
Event_State	BACnetEventState	STATE_NORMAL (0)	R	R
Reliability	BACnetReliability	NO_FAULT_DETECTED (0)	O	R
Out_Of_Service	BOOLEAN	FALSE	R	R
Polarity	BACnetPolarity	NORMAL (0)	R	R
Inactive_Text	CharacterString	"Reset"	O	R
Active_Text	CharacterString	"Not Reset"	O	R
Change_Of_State_Time	BACnetDatetime	-	O	-
Change_Of_State_Count	Unsigned	-	O	-
Time_Of_State_Count_Reset	BACnetDatetime	-	O	-
Elapsed_Active_Time	Unsigned	-	O	-
Time_Of_Active_Time_Reset	BACnetDatetime	-	O	-
Minimum_Off_Time	Unsigned32	-	O	-
Minimum_On_Time	Unsigned32	-	O	-
Priority_Array	BACnetPriorityArray	BACnetPriorityArray	R	R
Relinquish_Default	BACnetBinaryPV	INACTIVE (0)	R	R
Time_Delay	Unsigned	-	O	R*
Notification_Class	Unsigned	-	O	R*
Feedback_Value	BACnetBinaryPV	-	O	W
Event_Enable	BACnetEventTransitionBits	-	O	R*
Acked_Transitions	BACnetEventTransitionBits	-	O	R*
Notify_Type	BACnetNotifyType	-	O	R*
Event_Time_Stamps	BACnetArray[N] of BACnetTimeStamp	-	O	R*
Event_Message_Texts	BACnetArray[3] of CharacterString	-	O	-
Event_Message_Texts_Config	BACnetArray[3] of CharacterString	-	O	-

Event_Detection_Enable	BOOLEAN	-	O	R*
Event_Algorithm_Inhibit_Ref	BACnetObjectPropertyReference	-	O	-
Event_Algorithm_Inhibit	BOOLEAN	-	O	-
Time_Delay_Normal	Unsigned	-	O	-
Reliability_Evaluation_Inhibit	BOOLEAN	-	O	-
Property_List	BACnetArray[N] of BACnetPropertyIdentifier	BACnetArray[N]	R	R
Profile_Name	CharacterString	-	O	-

* Only available when specific object has a Notification Class configured

5.3.36 IU_rr_uu_TempLimValid_Setting (Binary Output Object Type)

Temperature upper and lower limit setting valid/invalid setting can be commanded for indoor unit.

Property Identifier	Property Datatype	Value	ASHRAE	UTY-VBGX
Object_Identifier	BACnetObjectIdentifier	(Binary Output, 13rruu)	R	R
Object_Name	CharacterString	"IU_rr_uu_TempLimValid_Setting"	R	R
Object_Type	BACnetObjectType	BINARY_OUTPUT (4)	R	R
Present_Value	BACnetBinaryPV	INACTIVE (0) / ACTIVE (1)	W	W
Description	CharacterString	-	O	-
Device_Type	CharacterString	-	O	-
Status_Flags	BACnetStatusFlags	{FALSE, FALSE, FALSE, FALSE}	R	R
Event_State	BACnetEventState	STATE_NORMAL (0)	R	R
Reliability	BACnetReliability	NO_FAULT_DETECTED (0)	O	R
Out_Of_Service	BOOLEAN	FALSE	R	R
Polarity	BACnetPolarity	NORMAL (0)	R	R
Inactive_Text	CharacterString	"Invalid"	O	R
Active_Text	CharacterString	"Valid"	O	R
Change_Of_State_Time	BACnetDatetime	-	O	-
Change_Of_State_Count	Unsigned	-	O	-
Time_Of_State_Count_Reset	BACnetDatetime	-	O	-
Elapsed_Active_Time	Unsigned	-	O	-
Time_Of_Active_Time_Reset	BACnetDatetime	-	O	-
Minimum_Off_Time	Unsigned32	-	O	-
Minimum_On_Time	Unsigned32	-	O	-
Priority_Array	BACnetPriorityArray	BACnetPriorityArray	R	R
Relinquish_Default	BACnetBinaryPV	INACTIVE (0)	R	R
Time_Delay	Unsigned	-	O	R*
Notification_Class	Unsigned	-	O	R*
Feedback_Value	BACnetBinaryPV	-	O	W
Event_Enable	BACnetEventTransitionBits	-	O	R*
Acked_Transitions	BACnetEventTransitionBits	-	O	R*
Notify_Type	BACnetNotifyType	-	O	R*
Event_Time_Stamps	BACnetArray[N] of BACnetTimeStamp	-	O	R*
Event_Message_Texts	BACnetArray[3] of CharacterString	-	O	-
Event_Message_Texts_Config	BACnetArray[3] of CharacterString	-	O	-

Event_Detection_Enable	BOOLEAN	-	O	R*
Event_Algorithm_Inhibit_Ref	BACnetObjectPropertyReference	-	O	-
Event_Algorithm_Inhibit	BOOLEAN	-	O	-
Time_Delay_Normal	Unsigned	-	O	-
Reliability_Evaluation_Inhibit	BOOLEAN	-	O	-
Property_List	BACnetArray[N] of BACnetPropertyIdentifier	BACnetArray[N]	R	R
Profile_Name	CharacterString	-	O	-

* Only available when specific object has a Notification Class configured

5.3.37 IU_rr_uu_OperationMode_Status (Multistate Input Object Type)

Indoor unit operation mode setting status can be monitored.

Property Identifier	Property Datatype	Value	ASHRAE	UTY-VBGX
Object_Identifier	BACnetObjectIdentifier	(Multistate Input, 10rruu)	R	R
Object_Name	CharacterString	"IU_rr_uu_OperationMode_Status"	R	R
Object_Type	BACnetObjectType	MULTISTATE_INPUT (13)	R	R
Present_Value	Unsigned	1 ~ 5	R	R
Description	CharacterString	-	O	-
Device_Type	CharacterString	-	O	-
Status_Flags	BACnetStatusFlags	{FALSE, FALSE/TRUE, FALSE, FALSE}	R	R
Event_State	BACnetEventState	STATE_NORMAL (0)	R	R
Reliability	BACnetReliability	NO_FAULT_DETECTED (0), UNRELIABLE_OTHER (7)	O	R
Out_Of_Service	BOOLEAN	FALSE	R	R
Number_Of_States	Unsigned	5	R	R
State_Text	BACnetArray[N] of CharacterString	<i>Check Operation Mode status below</i>	O	R
Time_Delay	Unsigned	-	O	R*
Notification_Class	Unsigned	-	O	R*
Alarm_Values	List of Unsigned	-	O	R*
Fault_Values	List of Unsigned	-	O	R*
Event_Enable	BACnetEventTransitionBits	-	O	R*
Acked_Transitions	BACnetEventTransitionBits	-	O	R*
Notify_Type	BACnetNotifyType	-	O	R*
Event_Time_Stamps	BACnetArray[N] of BACnetTimeStamp	-	O	R*
Event_Message_Texts	BACnetArray[3] of CharacterString	-	O	-
Event_Message_Texts_Config	BACnetArray[3] of CharacterString	-	O	-
Event_Detection_Enable	BOOLEAN	-	O	R*
Event_Algorithm_Inhibit_Ref	BACnetObjectPropertyReference	-	O	-
Event_Algorithm_Inhibit	BOOLEAN	-	O	-
Time_Delay_Normal	Unsigned	-	O	-
Reliability_Evaluation_Inhibit	BOOLEAN	-	O	-
Property_List	BACnetArray[N] of BACnetPropertyIdentifier	BACnetArray[N]	R	R
Profile_Name	CharacterString	-	O	-

* Only available when specific object has a Notification Class configured

Operation Mode status table

Mode status can be read using the values in the following correspondence table.

Pesent_Value	Contents displayed in State_Text
1	Cool
2	Heat
3	Fan
4	Dry
5	Auto

5.3.38 IU_rr_uu_FanSpeed_Status (Multistate Input Object Type)

Indoor unit air flow setting status can be monitored.

Property Identifier	Property Datatype	Value	ASHRAE	UTY-VBGX
Object_Identifier	BACnetObjectIdentifier	(Multistate Input, 11rruu)	R	R
Object_Name	CharacterString	"IU_rr_uu_FanSpeed_Status"	R	R
Object_Type	BACnetObjectType	MULTISTATE_INPUT (13)	R	R
Present_Value	Unsigned	1 ~ 7	R	R
Description	CharacterString	-	O	-
Device_Type	CharacterString	-	O	-
Status_Flags	BACnetStatusFlags	{FALSE, FALSE/TRUE, FALSE, FALSE}	R	R
Event_State	BACnetEventState	STATE_NORMAL (0)	R	R
Reliability	BACnetReliability	NO_FAULT_DETECTED (0), UNRELIABLE_OTHER (7)	O	R
Out_Of_Service	BOOLEAN	FALSE	R	R
Number_Of_States	Unsigned	7	R	R
State_Text	BACnetArray[N] of CharacterString	<i>Check Fan Speed status below</i>	O	R
Time_Delay	Unsigned	-	O	R*
Notification_Class	Unsigned	-	O	R*
Alarm_Values	List of Unsigned	-	O	R*
Fault_Values	List of Unsigned	-	O	R*
Event_Enable	BACnetEventTransitionBits	-	O	R*
Acked_Transitions	BACnetEventTransitionBits	-	O	R*
Notify_Type	BACnetNotifyType	-	O	R*
Event_Time_Stamps	BACnetArray[N] of BACnetTimeStamp	-	O	R*
Event_Message_Texts	BACnetArray[3] of CharacterString	-	O	-
Event_Message_Texts_Config	BACnetArray[3] of CharacterString	-	O	-
Event_Detection_Enable	BOOLEAN	-	O	R*
Event_Algorithm_Inhibit_Ref	BACnetObjectPropertyReference	-	O	-
Event_Algorithm_Inhibit	BOOLEAN	-	O	-
Time_Delay_Normal	Unsigned	-	O	-
Reliability_Evaluation_Inhibit	BOOLEAN	-	O	-
Property_List	BACnetArray[N] of BACnetPropertyIdentifier	BACnetArray[N]	R	R
Profile_Name	CharacterString	-	O	-

* Only available when specific object has a Notification Class configured

Fan Speed status table

Fan speed status can be read using the values in the following correspondence table.

Pesent_Value	Contents displayed in State_Text
1	Low
2	High
3	Med
4	Auto

Pesent_Value	Contents displayed in State_Text
5	Quiet
6	Med-Low
7	Med-High

5.3.39 IU_rr_uu_AirFlowDirVT_Status (Multistate Input Object Type)

Indoor unit vertical air flow position setting status can be monitored.

Property Identifier	Property Datatype	Value	ASHRAE	UTY-VBGX
Object_Identifier	BACnetObjectIdentifier	(Multistate Input, 12rruu)	R	R
Object_Name	CharacterString	"IU_rr_uu_AirFlowDirVT_Status"	R	R
Object_Type	BACnetObjectType	MULTISTATE_INPUT (13)	R	R
Present_Value	Unsigned	1 ~ 5	R	R
Description	CharacterString	-	O	-
Device_Type	CharacterString	-	O	-
Status_Flags	BACnetStatusFlags	{FALSE, FALSE/TRUE, FALSE, FALSE}	R	R
Event_State	BACnetEventState	STATE_NORMAL (0)	R	R
Reliability	BACnetReliability	NO_FAULT_DETECTED (0), UNRELIABLE_OTHER (7)	O	R
Out_Of_Service	BOOLEAN	FALSE	R	R
Number_Of_States	Unsigned	5	R	R
State_Text	BACnetArray[N] of CharacterString	<i>Check Air Flow Dir VT status below</i>	O	R
Time_Delay	Unsigned	-	O	R*
Notification_Class	Unsigned	-	O	R*
Alarm_Values	List of Unsigned	-	O	R*
Fault_Values	List of Unsigned	-	O	R*
Event_Enable	BACnetEventTransitionBits	-	O	R*
Acked_Transitions	BACnetEventTransitionBits	-	O	R*
Notify_Type	BACnetNotifyType	-	O	R*
Event_Time_Stamps	BACnetArray[N] of BACnetTimeStamp	-	O	R*
Event_Message_Texts	BACnetArray[3] of CharacterString	-	O	-
Event_Message_Texts_Config	BACnetArray[3] of CharacterString	-	O	-
Event_Detection_Enable	BOOLEAN	-	O	R*
Event_Algorithm_Inhibit_Ref	BACnetObjectPropertyReference	-	O	-
Event_Algorithm_Inhibit	BOOLEAN	-	O	-
Time_Delay_Normal	Unsigned	-	O	-
Reliability_Evaluation_Inhibit	BOOLEAN	-	O	-
Property_List	BACnetArray[N] of BACnetPropertyIdentifier	BACnetArray[N]	R	R
Profile_Name	CharacterString	-	O	-

* Only available when specific object has a Notification Class configured

Air Flow Dir VT status table

Vertical Air Flow direction status can be read using the values in the following correspondence table.

Pesent_Value	Contents displayed in State_Text
1	1
2	2
3	3
4	4
5	Swing

5.3.40 IU_rr_uu_AirFlowDirHZ_Status (Multistate Input Object Type)

Indoor unit horizontal air flow position setting status can be monitored.

Property Identifier	Property Datatype	Value	ASHRAE	UTY-VBGX
Object_Identifier	BACnetObjectIdentifier	(Multistate Input, 13rruu)	R	R
Object_Name	CharacterString	"IU_rr_uu_AirFlowDirHZ_Status"	R	R
Object_Type	BACnetObjectType	MULTISTATE_INPUT (13)	R	R
Present_Value	Unsigned	1 ~ 6	R	R
Description	CharacterString	-	O	-
Device_Type	CharacterString	-	O	-
Status_Flags	BACnetStatusFlags	{FALSE, FALSE/TRUE, FALSE, FALSE}	R	R
Event_State	BACnetEventState	STATE_NORMAL (0)	R	R
Reliability	BACnetReliability	NO_FAULT_DETECTED (0), UNRELIABLE_OTHER (7)	O	R
Out_Of_Service	BOOLEAN	FALSE	R	R
Number_Of_States	Unsigned	6	R	R
State_Text	BACnetArray[N] of CharacterString	<i>Check Air Flow Dir HZ status below</i>	O	R
Time_Delay	Unsigned	-	O	R*
Notification_Class	Unsigned	-	O	R*
Alarm_Values	List of Unsigned	-	O	R*
Fault_Values	List of Unsigned	-	O	R*
Event_Enable	BACnetEventTransitionBits	-	O	R*
Acked_Transitions	BACnetEventTransitionBits	-	O	R*
Notify_Type	BACnetNotifyType	-	O	R*
Event_Time_Stamps	BACnetArray[N] of BACnetTimeStamp	-	O	R*
Event_Message_Texts	BACnetArray[3] of CharacterString	-	O	-
Event_Message_Texts_Config	BACnetArray[3] of CharacterString	-	O	-
Event_Detection_Enable	BOOLEAN	-	O	R*
Event_Algorithm_Inhibit_Ref	BACnetObjectPropertyReference	-	O	-
Event_Algorithm_Inhibit	BOOLEAN	-	O	-
Time_Delay_Normal	Unsigned	-	O	-
Reliability_Evaluation_Inhibit	BOOLEAN	-	O	-
Property_List	BACnetArray[N] of BACnetPropertyIdentifier	BACnetArray[N]	R	R
Profile_Name	CharacterString	-	O	-

* Only available when specific object has a Notification Class configured

Air Flow Dir HZ status table

Horizontal Air Flow Direction status can be read using the values in the following correspondence table.

Pesent_Value	Contents displayed in State_Text
1	1
2	2
3	3
4	4
5	5
6	Swing

5.3.41 IU_rr_uu_RC_Prohibit_Status (Multistate Input Object Type)

Indoor unit remote controller prohibition setting status can be monitored.

Property Identifier	Property Datatype	Value	ASHRAE	UTY-VBGX
Object_Identifier	BACnetObjectIdentifier	(Multistate Input, 14rruu)	R	R
Object_Name	CharacterString	"IU_rr_uu_RC_Prohibit_Status"	R	R
Object_Type	BACnetObjectType	MULTISTATE_INPUT (13)	R	R
Present_Value	Unsigned	1 ~ 65	R	R
Description	CharacterString	-	O	-
Device_Type	CharacterString	-	O	-
Status_Flags	BACnetStatusFlags	{FALSE, FALSE/TRUE, FALSE, FALSE}	R	R
Event_State	BACnetEventState	STATE_NORMAL (0)	R	R
Reliability	BACnetReliability	NO_FAULT_DETECTED (0), UNRELIABLE_OTHER (7)	O	R
Out_Of_Service	BOOLEAN	FALSE	R	R
Number_Of_States	Unsigned	65	R	R
State_Text	BACnetArray[N] of CharacterString	Check RC Prohibition table (section 12.2)	O	R
Time_Delay	Unsigned	-	O	R*
Notification_Class	Unsigned	-	O	R*
Alarm_Values	List of Unsigned	-	O	R*
Fault_Values	List of Unsigned	-	O	R*
Event_Enable	BACnetEventTransitionBits	-	O	R*
Acked_Transitions	BACnetEventTransitionBits	-	O	R*
Notify_Type	BACnetNotifyType	-	O	R*
Event_Time_Stamps	BACnetArray[N] of BACnetTimeStamp	-	O	R*
Event_Message_Texts	BACnetArray[3] of CharacterString	-	O	-
Event_Message_Texts_Config	BACnetArray[3] of CharacterString	-	O	-
Event_Detection_Enable	BOOLEAN	-	O	R*
Event_Algorithm_Inhibit_Ref	BACnetObjectPropertyReference	-	O	-
Event_Algorithm_Inhibit	BOOLEAN	-	O	-
Time_Delay_Normal	Unsigned	-	O	-
Reliability_Evaluation_Inhibit	BOOLEAN	-	O	-
Property_List	BACnetArray[N] of BACnetPropertyIdentifier	BACnetArray[N]	R	R
Profile_Name	CharacterString	-	O	-

* Only available when specific object has a Notification Class configured

5.3.42 IU_rr_uu_Managed_Mode_Status (Multistate Input Object Type)

Indoor unit management status of auto mode can be monitored.

Property Identifier	Property Datatype	Value	ASHRAE	UTY-VBGX
Object_Identifier	BACnetObjectIdentifier	(Multistate Input, 16rruu)	R	R
Object_Name	CharacterString	"IU_rr_uu_Managed_Mode_Status"	R	R
Object_Type	BACnetObjectType	MULTISTATE_INPUT (13)	R	R
Present_Value	Unsigned	1 ~ 4	R	R
Description	CharacterString	-	O	-
Device_Type	CharacterString	-	O	-
Status_Flags	BACnetStatusFlags	{FALSE, FALSE/TRUE, FALSE, FALSE}	R	R
Event_State	BACnetEventState	STATE_NORMAL (0)	R	R
Reliability	BACnetReliability	NO_FAULT_DETECTED (0), UNRELIABLE_OTHER (7)	O	R
Out_Of_Service	BOOLEAN	FALSE	R	R
Number_Of_States	Unsigned	4	R	R
State_Text	BACnetArray[N] of CharacterString	<i>Check Managed Mode status below</i>	O	R
Time_Delay	Unsigned	-	O	R*
Notification_Class	Unsigned	-	O	R*
Alarm_Values	List of Unsigned	-	O	R*
Fault_Values	List of Unsigned	-	O	R*
Event_Enable	BACnetEventTransitionBits	-	O	R*
Acked_Transitions	BACnetEventTransitionBits	-	O	R*
Notify_Type	BACnetNotifyType	-	O	R*
Event_Time_Stamps	BACnetArray[N] of BACnetTimeStamp	-	O	R*
Event_Message_Texts	BACnetArray[3] of CharacterString	-	O	-
Event_Message_Texts_Config	BACnetArray[3] of CharacterString	-	O	-
Event_Detection_Enable	BOOLEAN	-	O	R*
Event_Algorithm_Inhibit_Ref	BACnetObjectPropertyReference	-	O	-
Event_Algorithm_Inhibit	BOOLEAN	-	O	-
Time_Delay_Normal	Unsigned	-	O	-
Reliability_Evaluation_Inhibit	BOOLEAN	-	O	-
Property_List	BACnetArray[N] of BACnetPropertyIdentifier	BACnetArray[N]	R	R
Profile_Name	CharacterString	-	O	-

* Only available when specific object has a Notification Class configured

Managed Mode status table

Vertical Air Flow direction status can be read using the values in the following correspondence table.

Present_Value	Contents displayed in State_Text	
1	Normal	
2	Master	Indicates setting to master indoor unit.
3	Slave	Indicates setting to managed indoor unit by master indoor unit.
4	External	Indicates setting to managed indoor unit by outdoor unit.

5.3.43 IU_rr_uu_ErrorCode_Status (Multistate Input Object Type)

The error code when an indoor unit error occurs can be checked.

Property Identifier	Property Datatype	Value	ASHRAE	UTY-VBGX
Object_Identifier	BACnetObjectIdentifier	(Multistate Input, 15rruu)	R	R
Object_Name	CharacterString	"IU_rr_uu_ErrorCode_Status"	R	R
Object_Type	BACnetObjectType	MULTISTATE_INPUT (13)	R	R
Present_Value	Unsigned	1 ~ 255	R	R
Description	CharacterString	-	O	-
Device_Type	CharacterString	-	O	-
Status_Flags	BACnetStatusFlags	{FALSE, FALSE/TRUE, FALSE, FALSE}	R	R
Event_State	BACnetEventState	STATE_NORMAL (0)	R	R
Reliability	BACnetReliability	NO_FAULT_DETECTED (0), UNRELIABLE_OTHER (7)	O	R
Out_Of_Service	BOOLEAN	FALSE	R	R
Number_Of_States	Unsigned	255	R	R
State_Text	BACnetArray[N] of CharacterString	-	O	-
Time_Delay	Unsigned	-	O	R*
Notification_Class	Unsigned	-	O	R*
Alarm_Values	List of Unsigned	-	O	R*
Fault_Values	List of Unsigned	-	O	R*
Event_Enable	BACnetEventTransitionBits	-	O	R*
Acked_Transitions	BACnetEventTransitionBits	-	O	R*
Notify_Type	BACnetNotifyType	-	O	R*
Event_Time_Stamps	BACnetArray[N] of BACnetTimeStamp	-	O	R*
Event_Message_Texts	BACnetArray[3] of CharacterString	-	O	-
Event_Message_Texts_Config	BACnetArray[3] of CharacterString	-	O	-
Event_Detection_Enable	BOOLEAN	-	O	R*
Event_Algorithm_Inhibit_Ref	BACnetObjectPropertyReference	-	O	-
Event_Algorithm_Inhibit	BOOLEAN	-	O	-
Time_Delay_Normal	Unsigned	-	O	-
Reliability_Evaluation_Inhibit	BOOLEAN	-	O	-
Property_List	BACnetArray[N] of BACnetPropertyIdentifier	BACnetArray[N]	R	R
Profile_Name	CharacterString	-	O	-

* Only available when specific object has a Notification Class configured

NOTE: For the error content, refer to the “Error content table (section 12.1)” using the Present_Value of the appropriate series.
Error contents may be added without prior notice.

5.3.44 IU_rr_uu_OperationMode_Setting (Multistate Output Object Type)

Operation mode can be set for indoor unit.

Property Identifier	Property Datatype	Value	ASHRAE	UTY-VBGX
Object_Identifier	BACnetObjectIdentifier	(Multistate Output, 10rruu)	R	R
Object_Name	CharacterString	"IU_rr_uu_OperationMode_Setting"	R	R
Object_Type	BACnetObjectType	MULTISTATE_OUTPUT (14)	R	R
Present_Value	Unsigned	1 ~ 5	W	W
Description	CharacterString	-	O	-
Device_Type	CharacterString	-	O	-
Status_Flags	BACnetStatusFlags	{FALSE, FALSE, FALSE, FALSE}	R	R
Event_State	BACnetEventState	STATE_NORMAL (0)	R	R
Reliability	BACnetReliability	NO_FAULT_DETECTED (0)	O	R
Out_Of_Service	BOOLEAN	FALSE	R	R
Number_Of_States	Unsigned	5	R	R
State_Text	BACnetArray[N] of CharacterString	Check Operation Mode settings below	O	R
Priority_Array	BACnetPriorityArray	BACnetPriorityArray	R	R
Relinquish_Default	Unsigned	1	R	R
Time_Delay	Unsigned	-	O	R*
Notification_Class	Unsigned	-	O	R*
Feedback_Value	Unsigned	-	O	W
Event_Enable	BACnetEventTransitionBits	-	O	R*
Acked_Transitions	BACnetEventTransitionBits	-	O	R*
Notify_Type	BACnetNotifyType	-	O	R*
Event_Time_Stamps	BACnetArray[N] of BACnetTimeStamp	-	O	R*
Event_Message_Texts	BACnetArray[3] of CharacterString	-	O	-
Event_Message_Texts_Config	BACnetArray[3] of CharacterString	-	O	-
Event_Detection_Enable	BOOLEAN	-	O	R*
Event_Algorithm_Inhibit_Ref	BACnetObjectPropertyReference	-	O	-
Event_Algorithm_Inhibit	BOOLEAN	-	O	-
Time_Delay_Normal	Unsigned	-	O	-
Reliability_Evaluation_Inhibit	BOOLEAN	-	O	-
Property_List	BACnetArray[N] of BACnetPropertyIdentifier	BACnetArray[N]	R	R
Profile_Name	CharacterString	-	O	-

* Only available when specific object has a Notification Class configured

Operation Mode settings table

Mode commands can be set using the values in the following correspondence table.

Pesent_Value	Contents displayed in State_Text
1	Cool
2	Heat
3	Fan
4	Dry
5	Auto

5.3.45 IU_rr_uu_FanSpeed_Setting (Multistate Output Object Type)

Air flow can be set for indoor unit.

Property Identifier	Property Datatype	Value	ASHRAE	UTY-VBGX
Object_Identifier	BACnetObjectIdentifier	(Multistate Output, 11rruu)	R	R
Object_Name	CharacterString	"IU_rr_uu_FanSpeed_Setting"	R	R
Object_Type	BACnetObjectType	MULTISTATE_OUTPUT (14)	R	R
Present_Value	Unsigned	1 ~ 7	W	W
Description	CharacterString	-	O	-
Device_Type	CharacterString	-	O	-
Status_Flags	BACnetStatusFlags	{FALSE, FALSE, FALSE, FALSE}	R	R
Event_State	BACnetEventState	STATE_NORMAL (0)	R	R
Reliability	BACnetReliability	NO_FAULT_DETECTED (0)	O	R
Out_Of_Service	BOOLEAN	FALSE	R	R
Number_Of_States	Unsigned	7	R	R
State_Text	BACnetArray[N] of CharacterString	<i>Check Fan Speed settings below</i>	O	R
Priority_Array	BACnetPriorityArray	-	R	R
Relinquish_Default	Unsigned	-	R	R
Time_Delay	Unsigned	-	O	R*
Notification_Class	Unsigned	-	O	R*
Feedback_Value	Unsigned	-	O	R*
Event_Enable	BACnetEventTransitionBits	-	O	R*
Acked_Transitions	BACnetEventTransitionBits	-	O	R*
Notify_Type	BACnetNotifyType	-	O	R*
Event_Time_Stamps	BACnetArray[N] of BACnetTimeStamp	-	O	R*
Event_Message_Texts	BACnetArray[3] of CharacterString	-	O	-
Event_Message_Texts_Config	BACnetArray[3] of CharacterString	-	O	-
Event_Detection_Enable	BOOLEAN	-	O	R*
Event_Algorithm_Inhibit_Ref	BACnetObjectPropertyReference	-	O	-
Event_Algorithm_Inhibit	BOOLEAN	-	O	-
Time_Delay_Normal	Unsigned	-	O	-
Reliability_Evaluation_Inhibit	BOOLEAN	-	O	-
Property_List	BACnetArray[N] of BACnetPropertyIdentifier	BACnetArray[N]	R	R
Profile_Name	CharacterString	-	O	-

* Only available when specific object has a Notification Class configured

Fan Speed settings table

Fan speed commands can be set using the values in the following correspondence table.

Pesent_Value	Contents displayed in State_Text
1	Low
2	High
3	Med
4	Auto

Pesent_Value	Contents displayed in State_Text
5	Quiet
6	Med-Low
7	Med-High

5.3.46 IU_rr_uu_AirFlowDirVT_Setting (Multistate Output Object Type)

Vertical air flow direction position can be set for indoor unit.

Property Identifier	Property Datatype	Value	ASHRAE	UTY-VBGX
Object_Identifier	BACnetObjectIdentifier	(Multistate Output, 12rruu)	R	R
Object_Name	CharacterString	"IU_rr_uu_AirFlowDirVT_Setting"	R	R
Object_Type	BACnetObjectType	MULTISTATE_OUTPUT (14)	R	R
Present_Value	Unsigned	1 ~ 5	W	W
Description	CharacterString	-	O	-
Device_Type	CharacterString	-	O	-
Status_Flags	BACnetStatusFlags	{FALSE, FALSE, FALSE, FALSE}	R	R
Event_State	BACnetEventState	STATE_NORMAL (0)	R	R
Reliability	BACnetReliability	NO_FAULT_DETECTED (0)	O	R
Out_Of_Service	BOOLEAN	FALSE	R	R
Number_Of_States	Unsigned	5	R	R
State_Text	BACnetArray[N] of CharacterString	<i>Check Air Flow Dir VT settngs below</i>	O	R
Priority_Array	BACnetPriorityArray	-	R	R
Relinquish_Default	Unsigned	-	R	R
Time_Delay	Unsigned	-	O	R*
Notification_Class	Unsigned	-	O	R*
Feedback_Value	Unsigned	-	O	R*
Event_Enable	BACnetEventTransitionBits	-	O	R*
Acked_Transitions	BACnetEventTransitionBits	-	O	R*
Notify_Type	BACnetNotifyType	-	O	R*
Event_Time_Stamps	BACnetArray[N] of BACnetTimeStamp	-	O	R*
Event_Message_Texts	BACnetArray[3] of CharacterString	-	O	-
Event_Message_Texts_Config	BACnetArray[3] of CharacterString	-	O	-
Event_Detection_Enable	BOOLEAN	-	O	R*
Event_Algorithm_Inhibit_Ref	BACnetObjectPropertyReference	-	O	-
Event_Algorithm_Inhibit	BOOLEAN	-	O	-
Time_Delay_Normal	Unsigned	-	O	-
Reliability_Evaluation_Inhibit	BOOLEAN	-	O	-
Property_List	BACnetArray[N] of BACnetPropertyIdentifier	BACnetArray[N]	R	R
Profile_Name	CharacterString	-	O	-

* Only available when specific object has a Notification Class configured

Air Flow Dir VT settings table

Vertical Air Flow Direction commands can be set using the values in the following correspondence table.

Pesent_Value	Contents displayed in State_Text
1	1
2	2
3	3
4	4
5	Swing

5.3.47 IU_rr_uu_AirFlowDirHZ_Setting (Multistate Output Object Type)

Horizontal air flow direction position can be set for indoor unit.

Property Identifier	Property Datatype	Value	ASHRAE	UTY-VBGX
Object_Identifier	BACnetObjectIdentifier	(Multistate Output, 13rruu)	R	R
Object_Name	CharacterString	"IU_rr_uu_AirFlowDirHZ_Setting"	R	R
Object_Type	BACnetObjectType	MULTISTATE_OUTPUT (14)	R	R
Present_Value	Unsigned	1 ~ 6	W	W
Description	CharacterString	-	O	-
Device_Type	CharacterString	-	O	-
Status_Flags	BACnetStatusFlags	{FALSE, FALSE, FALSE, FALSE}	R	R
Event_State	BACnetEventState	STATE_NORMAL (0)	R	R
Reliability	BACnetReliability	NO_FAULT_DETECTED (0)	O	R
Out_Of_Service	BOOLEAN	FALSE	R	R
Number_Of_States	Unsigned	6	R	R
State_Text	BACnetArray[N] of CharacterString	<i>Check Air Flow Dir HZ settings below</i>	O	R
Priority_Array	BACnetPriorityArray	-	R	R
Relinquish_Default	Unsigned	-	R	R
Time_Delay	Unsigned	-	O	R*
Notification_Class	Unsigned	-	O	R*
Feedback_Value	Unsigned	-	O	R*
Event_Enable	BACnetEventTransitionBits	-	O	R*
Acked_Transitions	BACnetEventTransitionBits	-	O	R*
Notify_Type	BACnetNotifyType	-	O	R*
Event_Time_Stamps	BACnetArray[N] of BACnetTimeStamp	-	O	R*
Event_Message_Texts	BACnetArray[3] of CharacterString	-	O	-
Event_Message_Texts_Config	BACnetArray[3] of CharacterString	-	O	-
Event_Detection_Enable	BOOLEAN	-	O	R*
Event_Algorithm_Inhibit_Ref	BACnetObjectPropertyReference	-	O	-
Event_Algorithm_Inhibit	BOOLEAN	-	O	-
Time_Delay_Normal	Unsigned	-	O	-
Reliability_Evaluation_Inhibit	BOOLEAN	-	O	-
Property_List	BACnetArray[N] of BACnetPropertyIdentifier	BACnetArray[N]	R	R
Profile_Name	CharacterString	-	O	-

* Only available when specific object has a Notification Class configured

Air Flow Dir HZ settings table

Horizontal Air Flow Direction commands can be set using the values in the following correspondence table.

Pesent_Value	Contents displayed in State_Text
1	1
2	2
3	3
4	4
5	5
6	Swing

5.3.48 IU_rr_uu_RC_Prohibit_Setting (Multistate Output Object Type)

Remote controller prohibition can be set for indoor unit.

Property Identifier	Property Datatype	Value	ASHRAE	UTY-VBGX
Object_Identifier	BACnetObjectIdentifier	(Multistate Output, 14rruu)	R	R
Object_Name	CharacterString	"IU_rr_uu_RC_Prohibit_Setting"	R	R
Object_Type	BACnetObjectType	MULTISTATE_OUTPUT (14)	R	R
Present_Value	Unsigned	1 ~ 65	W	W
Description	CharacterString	-	O	-
Device_Type	CharacterString	-	O	-
Status_Flags	BACnetStatusFlags	{FALSE, FALSE, FALSE, FALSE}	R	R
Event_State	BACnetEventState	STATE_NORMAL (0)	R	R
Reliability	BACnetReliability	NO_FAULT_DETECTED (0)	O	R
Out_Of_Service	BOOLEAN	FALSE	R	R
Number_Of_States	Unsigned	65	R	R
State_Text	BACnetArray[N] of CharacterString	Check RC Prohibition table (section 12.2)	O	R
Priority_Array	BACnetPriorityArray	-	R	R
Relinquish_Default	Unsigned	-	R	R
Time_Delay	Unsigned	-	O	R*
Notification_Class	Unsigned	-	O	R*
Feedback_Value	Unsigned	-	O	R*
Event_Enable	BACnetEventTransitionBits	-	O	R*
Acked_Transitions	BACnetEventTransitionBits	-	O	R*
Notify_Type	BACnetNotifyType	-	O	R*
Event_Time_Stamps	BACnetArray[N] of BACnetTimeStamp	-	O	R*
Event_Message_Texts	BACnetArray[3] of CharacterString	-	O	-
Event_Message_Texts_Config	BACnetArray[3] of CharacterString	-	O	-
Event_Detection_Enable	BOOLEAN	-	O	R*
Event_Algorithm_Inhibit_Ref	BACnetObjectPropertyReference	-	O	-
Event_Algorithm_Inhibit	BOOLEAN	-	O	-
Time_Delay_Normal	Unsigned	-	O	-
Reliability_Evaluation_Inhibit	BOOLEAN	-	O	-
Property_List	BACnetArray[N] of BACnetPropertyIdentifier	BACnetArray[N]	R	R
Profile_Name	CharacterString	-	O	-

* Only available when specific object has a Notification Class configured

5.3.49 OU_rr_uu_Error_Status (Binary Input Object Type)

The normal and error statuses of outdoor unit can be monitored.

Property Identifier	Property Datatype	Value	ASHRAE	UTY-VBGX
Object_Identifier	BACnetObjectIdentifier	(Binary Input, 30rruu)	R	R
Object_Name	CharacterString	"OU_rr_uu_Error_Status"	R	R
Object_Type	BACnetObjectType	BINARY_INPUT (3)	R	R
Present_Value	BACnetBinaryPV	INACTIVE (0) / ACTIVE (1)	R	R
Description	CharacterString	-	O	-
Device_Type	CharacterString	-	O	-
Status_Flags	BACnetStatusFlags	{FALSE, FALSE/TRUE, FALSE, FALSE}	R	R
Event_State	BACnetEventState	STATE_NORMAL (0)	R	R
Reliability	BACnetReliability	NO_FAULT_DETECTED (0), UNRELIABLE_OTHER (7)	O	R
Out_Of_Service	BOOLEAN	FALSE	R	R
Polarity	BACnetPolarity	NORMAL (0)	R	R
Inactive_Text	CharacterString	"Normal"	O	R
Active_Text	CharacterString	"Fault"	O	R
Change_Of_State_Time	BACnetDatetime	-	O	-
Change_Of_State_Count	Unsigned	-	O	-
Time_Of_State_Count_Reset	BACnetDatetime	-	O	-
Elapsed_Active_Time	Unsigned	-	O	-
Time_Of_Active_Time_Reset	BACnetDatetime	-	O	-
Time_Delay	Unsigned	-	O	R*
Notification_Class	Unsigned	-	O	R*
Alarm_Value	BACnetBinaryPV	-	O	R*
Event_Enable	BACnetEventTransitionBits	-	O	R*
Acked_Transitions	BACnetEventTransitionBits	-	O	R*
Notify_Type	BACnetNotifyType	-	O	R*
Event_Time_Stamps	BACnetArray[N] of BACnetTimeStamp	-	O	R*
Event_Message_Texts	BACnetArray[3] of CharacterString	-	O	-
Event_Message_Texts_Config	BACnetArray[3] of CharacterString	-	O	-
Event_Detection_Enable	BOOLEAN	-	O	R*
Event_Algorithm_Inhibit_Ref	BACnetObjectPropertyReference	-	O	-
Event_Algorithm_Inhibit	BOOLEAN	-	O	-
Time_Delay_Normal	Unsigned	-	O	-

Reliability_Evaluation_Inhibit	BOOLEAN	-	O	-
Property_List	BACnetArray[N] of BACnetPropertyIdentifier	BACnetArray[N]	R	R
Profile_Name	CharacterString	-	O	-

* Only available when specific object has a Notification Class configured

5.3.50 OU_rr_uu_ErrorCode_Status (Multistate Input Object Type)

The error code when an outdoor unit error occurs can be checked.

Property Identifier	Property Datatype	Value	ASHRAE	UTY-VBGX
Object_Identifier	BACnetObjectIdentifier	(Multistate Input, 31rruu)	R	R
Object_Name	CharacterString	"OU_rr_uu_ErrorCode_Status"	R	R
Object_Type	BACnetObjectType	MULTISTATE_INPUT (13)	R	R
Present_Value	Unsigned	1 ~ 255	R	R
Description	CharacterString	-	O	-
Device_Type	CharacterString	-	O	-
Status_Flags	BACnetStatusFlags	{FALSE, FALSE/TRUE, FALSE, FALSE}	R	R
Event_State	BACnetEventState	STATE_NORMAL (0)	R	R
Reliability	BACnetReliability	NO_FAULT_DETECTED (0), UNRELIABLE_OTHER (7)	O	R
Out_Of_Service	BOOLEAN	FALSE	R	R
Number_Of_States	Unsigned	255	R	R
State_Text	BACnetArray[N] of CharacterString	-	O	-
Time_Delay	Unsigned	-	O	R*
Notification_Class	Unsigned	-	O	R*
Alarm_Values	List of Unsigned	-	O	R*
Fault_Values	List of Unsigned	-	O	R*
Event_Enable	BACnetEventTransitionBits	-	O	R*
Acked_Transitions	BACnetEventTransitionBits	-	O	R*
Notify_Type	BACnetNotifyType	-	O	R*
Event_Time_Stamps	BACnetArray[N] of BACnetTimeStamp	-	O	R*
Event_Message_Texts	BACnetArray[3] of CharacterString	-	O	-
Event_Message_Texts_Config	BACnetArray[3] of CharacterString	-	O	-
Event_Detection_Enable	BOOLEAN	-	O	R*
Event_Algorithm_Inhibit_Ref	BACnetObjectPropertyReference	-	O	-
Event_Algorithm_Inhibit	BOOLEAN	-	O	-
Time_Delay_Normal	Unsigned	-	O	-
Reliability_Evaluation_Inhibit	BOOLEAN	-	O	-
Property_List	BACnetArray[N] of BACnetPropertyIdentifier	BACnetArray[N]	R	R
Profile_Name	CharacterString	-	O	-

* Only available when specific object has a Notification Class configured

NOTE: For the error content, refer to the “Error content table (section 12.1)” using the Present_Value of the appropriate series.

Error contents may be added without prior notice.

5.3.51 OU_rr_uu_ForcedOff_Status (Binary Input Object Type)

Outdoor unit forced stop setting status can be monitored.

Property Identifier	Property Datatype	Value	ASHRAE	UTY-VBGX
Object_Identifier	BACnetObjectIdentifier	(Binary Input, 31rruu)	R	R
Object_Name	CharacterString	"OU_rr_uu_ForcedOff_Status"	R	R
Object_Type	BACnetObjectType	BINARY_INPUT (3)	R	R
Present_Value	BACnetBinaryPV	INACTIVE (0) / ACTIVE (1)	R	R
Description	CharacterString	-	O	-
Device_Type	CharacterString	-	O	-
Status_Flags	BACnetStatusFlags	{FALSE, FALSE/TRUE, FALSE, FALSE}	R	R
Event_State	BACnetEventState	STATE_NORMAL (0)	R	R
Reliability	BACnetReliability	NO_FAULT_DETECTED (0), UNRELIABLE_OTHER (7)	O	R
Out_Of_Service	BOOLEAN	FALSE	R	R
Polarity	BACnetPolarity	NORMAL (0)	R	R
Inactive_Text	CharacterString	"Reset"	O	R
Active_Text	CharacterString	"Set"	O	R
Change_Of_State_Time	BACnetDatetime	-	O	-
Change_Of_State_Count	Unsigned	-	O	-
Time_Of_State_Count_Reset	BACnetDatetime	-	O	-
Elapsed_Active_Time	Unsigned	-	O	-
Time_Of_Active_Time_Reset	BACnetDatetime	-	O	-
Time_Delay	Unsigned	-	O	R*
Notification_Class	Unsigned	-	O	R*
Alarm_Value	BACnetBinaryPV	-	O	R*
Event_Enable	BACnetEventTransitionBits	-	O	R*
Acked_Transitions	BACnetEventTransitionBits	-	O	R*
Notify_Type	BACnetNotifyType	-	O	R*
Event_Time_Stamps	BACnetArray[N] of BACnetTimeStamp	-	O	R*
Event_Message_Texts	BACnetArray[3] of CharacterString	-	O	-
Event_Message_Texts_Config	BACnetArray[3] of CharacterString	-	O	-
Event_Detection_Enable	BOOLEAN	-	O	R*
Event_Algorithm_Inhibit_Ref	BACnetObjectPropertyReference	-	O	-
Event_Algorithm_Inhibit	BOOLEAN	-	O	-
Time_Delay_Normal	Unsigned	-	O	-

Reliability_Evaluation_Inhibit	BOOLEAN	-	O	-
Property_List	BACnetArray[N] of BACnetPropertyIdentifier	BACnetArray[N]	R	R
Profile_Name	CharacterString	-	O	-

* Only available when specific object has a Notification Class configured

5.3.52 OU_rr_uu_CapacitySave_Status (Multistate Input Object Type)

Use this object to monitor capacity save setting status of outdoor unit.

Property Identifier	Property Datatype	Value	ASHRAE	UTY-VBGX
Object_Identifier	BACnetObjectIdentifier	(Multistate Input, 32rruu)	R	R
Object_Name	CharacterString	"OU_rr_uu_CapacitySave_Status"	R	R
Object_Type	BACnetObjectType	MULTISTATE_INPUT (13)	R	R
Present_Value	Unsigned	1 ~ 8	R	R
Description	CharacterString	-	O	-
Device_Type	CharacterString	-	O	-
Status_Flags	BACnetStatusFlags	{FALSE, FALSE/TRUE, FALSE, FALSE}	R	R
Event_State	BACnetEventState	STATE_NORMAL (0)	R	R
Reliability	BACnetReliability	NO_FAULT_DETECTED (0), UNRELIABLE_OTHER (7)	O	R
Out_Of_Service	BOOLEAN	FALSE	R	R
Number_Of_States	Unsigned	8	R	R
State_Text	BACnetArray[N] of CharacterString	<i>Check Capacity Save status below</i>	O	R
Time_Delay	Unsigned	-	O	R*
Notification_Class	Unsigned	-	O	R*
Alarm_Values	List of Unsigned	-	O	R*
Fault_Values	List of Unsigned	-	O	R*
Event_Enable	BACnetEventTransitionBits	-	O	R*
Acked_Transitions	BACnetEventTransitionBits	-	O	R*
Notify_Type	BACnetNotifyType	-	O	R*
Event_Time_Stamps	BACnetArray[N] of BACnetTimeStamp	-	O	R*
Event_Message_Texts	BACnetArray[3] of CharacterString	-	O	-
Event_Message_Texts_Config	BACnetArray[3] of CharacterString	-	O	-
Event_Detection_Enable	BOOLEAN	-	O	R*
Event_Algorithm_Inhibit_Ref	BACnetObjectPropertyReference	-	O	-
Event_Algorithm_Inhibit	BOOLEAN	-	O	-
Time_Delay_Normal	Unsigned	-	O	-
Reliability_Evaluation_Inhibit	BOOLEAN	-	O	-
Property_List	BACnetArray[N] of BACnetPropertyIdentifier	BACnetArray[N]	R	R
Profile_Name	CharacterString	-	O	-

* Only available when specific object has a Notification Class configured

Capacity Save status table

Capacity Save status can be read using the values in the following correspondence table.

Pesent_Value	Contents displayed in State_Text
1	Not set
2	100%
3	90%
4	80%

Pesent_Value	Contents displayed in State_Text
5	70%
6	60%
7	50%
8	40%

5.3.53 OU_rr_uu_CapacitySave_Setting (Multistate Output Object Type)

Use this object to set capacity save of outdoor units.

Property Identifier	Property Datatype	Value	ASHRAE	UTY-VBGX
Object_Identifier	BACnetObjectIdentifier	(Multistate Output, 32rruu)	R	R
Object_Name	CharacterString	"OU_rr_uu_CapacitySave_Setting"	R	R
Object_Type	BACnetObjectType	MULTISTATE_OUTPUT (14)	R	R
Present_Value	Unsigned	1 ~ 8	W	W
Description	CharacterString	-	O	-
Status_Flags	BACnetStatusFlags	{FALSE, FALSE, FALSE, FALSE}	R	R
Event_State	BACnetEventState	STATE_NORMAL (0)	R	R
Reliability	BACnetReliability	NO_FAULT_DETECTED (0)	O	R
Out_Of_Service	BOOLEAN	FALSE	R	R
Number_Of_States	Unsigned	8	R	R
State_Text	BACnetArray[N] of CharacterString	Check Capacity Save setting below	O	R
Priority_Array	BACnetPriorityArray	-	R	R
Relinquish_Default	Unsigned	-	R	R
Time_Delay	Unsigned	-	O	R*
Notification_Class	Unsigned	-	O	R*
Feedback_Value	Unsigned	-	O	R*
Event_Enable	BACnetEventTransitionBits	-	O	R*
Acked_Transitions	BACnetEventTransitionBits	-	O	R*
Notify_Type	BACnetNotifyType	-	O	R*
Event_Time_Stamps	BACnetArray[N] of BACnetTimeStamp	-	O	R*
Event_Message_Texts	BACnetArray[3] of CharacterString	-	O	-
Event_Message_Texts_Config	BACnetArray[3] of CharacterString	-	O	-
Event_Detection_Enable	BOOLEAN	-	O	R*
Event_Algorithm_Inhibit_Ref	BACnetObjectPropertyReference	-	O	-
Event_Algorithm_Inhibit	BOOLEAN	-	O	-
Time_Delay_Normal	Unsigned	-	O	-
Reliability_Evaluation_Inhibit	BOOLEAN	-	O	-
Property_List	BACnetArray[N] of BACnetPropertyIdentifier	BACnetArray[N]	R	R
Profile_Name	CharacterString	-	O	-

* Only available when specific object has a Notification Class configured

Capacity Save setting table

Capacity Save can be set using the values in the following correspondence table.

Pesent_Value	Contents displayed in State_Text
1	Not set
2	100%
3	90%
4	80%

Pesent_Value	Contents displayed in State_Text
5	70%
6	60%
7	50%
8	40%

5.3.54 OU_rr_uu_ForcedOff_Setting (Binary Output Object Type)

Forced stop setting can be commanded for outdoor unit.

Property Identifier	Property Datatype	Value	ASHRAE	UTY-VBGX
Object_Identifier	BACnetObjectIdentifier	(Binary Output, 30rruu)	R	R
Object_Name	CharacterString	"OU_rr_uu_ForcedOff_Setting"	R	R
Object_Type	BACnetObjectType	BINARY_OUTPUT (4)	R	R
Present_Value	BACnetBinaryPV	INACTIVE (0) / ACTIVE (1)	W	W
Description	CharacterString	-	O	-
Device_Type	CharacterString	-	O	-
Status_Flags	BACnetStatusFlags	{FALSE, FALSE, FALSE, FALSE}	R	R
Event_State	BACnetEventState	STATE_NORMAL (0)	R	R
Reliability	BACnetReliability	NO_FAULT_DETECTED (0)	O	R
Out_Of_Service	BOOLEAN	FALSE	R	R
Polarity	BACnetPolarity	NORMAL (0)	R	R
Inactive_Text	CharacterString	"Reset"	O	R
Active_Text	CharacterString	"Set"	O	R
Change_Of_State_Time	BACnetDatetime	-	O	-
Change_Of_State_Count	Unsigned	-	O	-
Time_Of_State_Count_Reset	BACnetDatetime	-	O	-
Elapsed_Active_Time	Unsigned	-	O	-
Time_Of_Active_Time_Reset	BACnetDatetime	-	O	-
Minimum_Off_Time	Unsigned32	-	O	-
Minimum_On_Time	Unsigned32	-	O	-
Priority_Array	BACnetPriorityArray	BACnetPriorityArray	R	R
Relinquish_Default	BACnetBinaryPV	INACTIVE (0)	R	R
Time_Delay	Unsigned	-	O	R*
Notification_Class	Unsigned	-	O	R*
Feedback_Value	BACnetBinaryPV	-	O	W
Event_Enable	BACnetEventTransitionBits	-	O	R*
Acked_Transitions	BACnetEventTransitionBits	-	O	R*
Notify_Type	BACnetNotifyType	-	O	R*
Event_Time_Stamps	BACnetArray[N] of BACnetTimeStamp	-	O	R*
Event_Message_Texts	BACnetArray[3] of CharacterString	-	O	-
Event_Message_Texts_Config	BACnetArray[3] of CharacterString	-	O	-

Event_Detection_Enable	BOOLEAN	-	O	R*
Event_Algorithm_Inhibit_Ref	BACnetObjectPropertyReference	-	O	-
Event_Algorithm_Inhibit	BOOLEAN	-	O	-
Time_Delay_Normal	Unsigned	-	O	-
Reliability_Evaluation_Inhibit	BOOLEAN	-	O	-
Property_List	BACnetArray[N] of BACnetPropertyIdentifier	BACnetArray[N]	R	R
Profile_Name	CharacterString	-	O	-

* Only available when specific object has a Notification Class configured.

5.3.55 OU_rr_uu_LowNoiseOp_Status (Multistate Input Object Type)

Low noise operation status for an outdoor unit can be monitored.

Property Identifier	Property Datatype	Value	ASHRAE	UTY-VBGX
Object_Identifier	BACnetObjectIdentifier	(Multistate Input, 32rruu)	R	R
Object_Name	CharacterString	"OU_rr_uu_LowNoiseOp_Status"	R	R
Object_Type	BACnetObjectType	MULTISTATE_INPUT (13)	R	R
Present_Value	Unsigned	1 ~ 16	R	R
Description	CharacterString	-	O	-
Device_Type	CharacterString	-	O	-
Status_Flags	BACnetStatusFlags	{FALSE, FALSE/TRUE, FALSE, FALSE}	R	R
Event_State	BACnetEventState	STATE_NORMAL (0)	R	R
Reliability	BACnetReliability	NO_FAULT_DETECTED (0), UNRELIABLE_OTHER (7)	O	R
Out_Of_Service	BOOLEAN	FALSE	R	R
Number_Of_States	Unsigned	16	R	R
State_Text	BACnetArray[N] of CharacterString	<i>Check Low Noise Operation status below</i>	O	R
Time_Delay	Unsigned	-	O	R*
Notification_Class	Unsigned	-	O	R*
Alarm_Values	List of Unsigned	-	O	R*
Fault_Values	List of Unsigned	-	O	R*
Event_Enable	BACnetEventTransitionBits	-	O	R*
Acked_Transitions	BACnetEventTransitionBits	-	O	R*
Notify_Type	BACnetNotifyType	-	O	R*
Event_Time_Stamps	BACnetArray[N] of BACnetTimeStamp	-	O	R*
Event_Message_Texts	BACnetArray[3] of CharacterString	-	O	-
Event_Message_Texts_Config	BACnetArray[3] of CharacterString	-	O	-
Event_Detection_Enable	BOOLEAN	-	O	R*
Event_Algorithm_Inhibit_Ref	BACnetObjectPropertyReference	-	O	-
Event_Algorithm_Inhibit	BOOLEAN	-	O	-
Time_Delay_Normal	Unsigned	-	O	-
Reliability_Evaluation_Inhibit	BOOLEAN	-	O	-
Property_List	BACnetArray[N] of BACnetPropertyIdentifier	BACnetArray[N]	R	R
Profile_Name	CharacterString	-	O	-

* Only available when specific object has a Notification Class configured

Low Noise Operating status table

Low Noise Operation Status can be checked using the values in the following correspondence table.

Pesent_Value	Contents displayed in State_Text
1	Not Set
2	-/-/E
3	-/A/-
4	-/A/E
5	1/-/-
6	1/-/E
7	1/A/-
8	1/A/E

Pesent_Value	Contents displayed in State_Text
9	2/-/-
10	2/-/E
11	2/A/-
12	2/A/E
13	3/-/-
14	3/-/E
15	3/A/-
16	3/A/E

A single low noise operation value of outdoor unit, represents 3 different operation values:

Lv/A/E

Lv: Low noise level (bigger value for lower noise)

A: Ability to support both low noise and air conditioning performance when performance priority is specified against low noise operation. Low noise operation will not be activated if performance priority is specified and this value is set.

E: Simultaneously controlled through external input of outdoor unit.

If this value is set, the actual low noise operation will also depend on the external input signal connected to the outdoor unit.

5.3.56 OU_rr_uu_LowNoiseOp_Setting (Multistate Output Object Type)

Low noise operation can be commanded for an outdoor unit.

Property Identifier	Property Datatype	Value	ASHRAE	UTY-VBGX
Object_Identifier	BACnetObjectIdentifier	(Multistate Output, 30rruu)	R	R
Object_Name	CharacterString	"OU_rr_uu_LowNoiseOp_Setting"	R	R
Object_Type	BACnetObjectType	MULTISTATE_OUTPUT (14)	R	R
Present_Value	Unsigned	1 ~ 7	W	W
Description	CharacterString	-	O	-
Status_Flags	BACnetStatusFlags	{FALSE, FALSE, FALSE, FALSE}	R	R
Event_State	BACnetEventState	STATE_NORMAL (0)	R	R
Reliability	BACnetReliability	NO_FAULT_DETECTED (0)	O	R
Out_Of_Service	BOOLEAN	FALSE	R	R
Number_Of_States	Unsigned	7	R	R
State_Text	BACnetArray[N] of CharacterString	<i>Check Low Noise Operation setting below</i>	O	R
Priority_Array	BACnetPriorityArray	-	R	R
Relinquish_Default	Unsigned	-	R	R
Time_Delay	Unsigned	-	O	R*
Notification_Class	Unsigned	-	O	R*
Feedback_Value	Unsigned	-	O	R*
Event_Enable	BACnetEventTransitionBits	-	O	R*
Acked_Transitions	BACnetEventTransitionBits	-	O	R*
Notify_Type	BACnetNotifyType	-	O	R*
Event_Time_Stamps	BACnetArray[N] of BACnetTimeStamp	-	O	R*
Event_Message_Texts	BACnetArray[3] of CharacterString	-	O	-
Event_Message_Texts_Config	BACnetArray[3] of CharacterString	-	O	-
Event_Detection_Enable	BOOLEAN	-	O	R*
Event_Algorithm_Inhibit_Ref	BACnetObjectPropertyReference	-	O	-
Event_Algorithm_Inhibit	BOOLEAN	-	O	-
Time_Delay_Normal	Unsigned	-	O	-
Reliability_Evaluation_Inhibit	BOOLEAN	-	O	-
Property_List	BACnetArray[N] of BACnetPropertyIdentifier	BACnetArray[N]	R	R
Profile_Name	CharacterString	-	O	-

* Only available when specific object has a Notification Class configured

Low Noise Operating setting table

Low Noise Operating commands can be set using the values in the following correspondence table.

Pesent_Value	Contents displayed in State_Text
1	Stop
2	Level1-Quiet
3	Level1-Ability
4	Level2-Quiet

Pesent_Value	Contents displayed in State_Text
5	Level2-Ability
6	Level3-Quiet
7	Level3-Ability

5.3.57 Notification Class Object Type

Property Identifier	Property Datatype	Value	ASHRAE	UTY-VBGX
Object_Identifier	BACnetObjectIdentifier	(Notification_Class, 15)	R	R
Object_Name	CharacterString	"NotificationClass_0" ~ "NotificationClass_9"	R	R
Object_Type	BACnetObjectType	NOTIFICATION_CLASS (15)	R	R
Description	CharacterString	-	O	-
Notification_Class	Unsigned	-	R	R
Priority	BACnetARRAY[3] of Unsigned	-	R	R
Ack_Required	BACnetEventTransitionBits	-	R	R
Recipient_List	BACnetLIST of BACnetDestination	-	R	R
Property_List	BACnetArray[N] of BACnetPropertyIdentifier	BACnetArray[N]	R	R
Profile_Name	CharacterString	-	O	-

6 Installation

Observe the warning and caution described below, when installing the BACnet Gateway.

⚠ WARNING	This mark indicates procedures which, if improperly performed, might lead to the death or serious injury of the user.
Always use the accessories and specified installation work parts. Check the state of the installation parts. Not using the specified parts will cause units to fall off, electric shock, fire, etc.	
Install at a place that can withstand the weight of the unit and install positively so that the unit will not topple or fall.	
When installing this unit, make sure that there are no children nearby. Otherwise, injury or electric shock could result.	
Install a circuit breaker. Otherwise, electric shock or fire could result.	
Avoid installing in a place where substances like sulfuric gas, chloric gas, acid or alkaline that may contaminate the devices, are generated.	

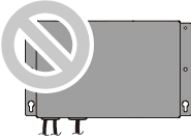
⚠ CAUTION	This mark indicates procedures which, if improperly performed, might possibly result in personal harm to the user or damage to property.
Do not push any SW, set the DIP switch or rotary switch of this unit except as specified in this installation manual or the instruction manual supplied with the air conditioner. Setting the switches other than specified will cause an accident or trouble.	
Use an insulated screwdriver to set the DIP switches.	
Before opening the cover of this unit, completely discharge static electricity charged on your body. Otherwise, failure or malfunction could result.	
Do not touch the circuit board and circuit board parts directly with your hands. Otherwise, injury or electric shock could result.	
Tightening the mounting screws too tight will damage the body of this unit.	
Be careful so that the cover does not fall after the cover screws are removed. Otherwise, injury could result.	
Do not install the main unit with the cables downward.	
	

6.1 Safety Precautions

- The “SAFETY PRECAUTIONS” indicated in this manual contain important information pertaining to your safety. Be sure to observe them.
- Request the user to keep this manual on hand for future use, such as for relocating or repairing the unit.

⚠ WARNING	
Each terminal marked with ⊕ shall be securely connected to grounding, not allowed to be blank	
Perform electrical work by an authorized service personnel in accordance with this manual and the electrical wiring regulations or implementation regulations of the country. Also do not install this unit by yourself. Improper electric work will cause electric shock or a fire.	
Perform installation work in accordance with this manual. Request an authorized service personnel to perform installation work. Do not install this unit by yourself. Improper installation will cause injury, electric shock, fire, etc.	
In the event of a malfunction (burning smell, etc.), immediately stop operation, turn off the electrical breaker, and consult authorized service personnel.	
Install a leakage circuit breaker to power supply cable in accordance with the related laws and regulations and electric company standards.	
Use a power source exclusively for this unit. Never share the power source with other electrical equipment. Doing so will cause fire and electric shock.	

⚠ WARNING

For proper ground connection do not miss screws with serrated washer when fixing enclosure cover.

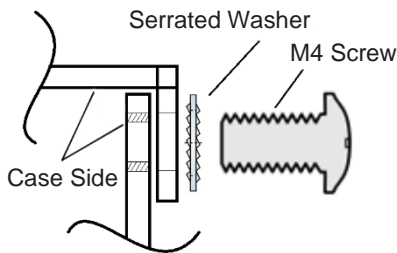

Do not install the unit in the following areas:

- Do not install the unit near a source of heat, steam, or flammable gas.
- Area filled with mineral oil or containing a large amount of splashed oil or steam, such as a kitchen. It will deteriorate plastic parts, causing the parts to fail or the unit to leak water.
- Area that generates substances that adversely affect the equipment, such as sulfuric gas, chlorine gas, acid, or alkali. It will cause the copper pipes and brazed joints to corrode, which can cause refrigerant leakage.
- Area containing equipment that generates electromagnetic interference. It will cause the control system to malfunction, preventing the unit from operating normally.
- Area that can cause combustible gas to leak, contains suspended carbon fibers or flammable dust, or volatile inflammables such as paint thinner or gasoline. If gas leaks and settles around the unit, it can cause a fire.
- Do not use the unit for special purposes, such as storing food, raising animals, growing plants, or preserving precision devices or art objects. It can degrade the quality of the preserved or stored objects.
- Install the unit in a well-ventilated place avoiding rains and direct sunlight.

Do not operate this unit when your hands are wet. Touching the unit with wet hands will cause an electric shock.

If children may approach the unit, take preventive measures so that they cannot reach the unit.

⚠ CAUTION

Pay abundant care when transporting this unit because it is a precision device. Improper transportation will cause trouble.

Do not touch the switches with sharp objects. Doing so will cause injury, trouble, or electric shock.

Do not expose this unit directly to water. Doing so will cause trouble, electric shock, or heating.

Do not set vessels containing a liquid on this unit. Doing so will cause heating, fire, or electric shock.

Dispose of the packing materials safely. Tear and dispose of the plastic packing bags so that children cannot play with them. There is the danger of suffocation if children play with the original plastic bags.

Do not insert articles into the slit parts of this unit. Doing so will cause trouble, heating, or electric shock.

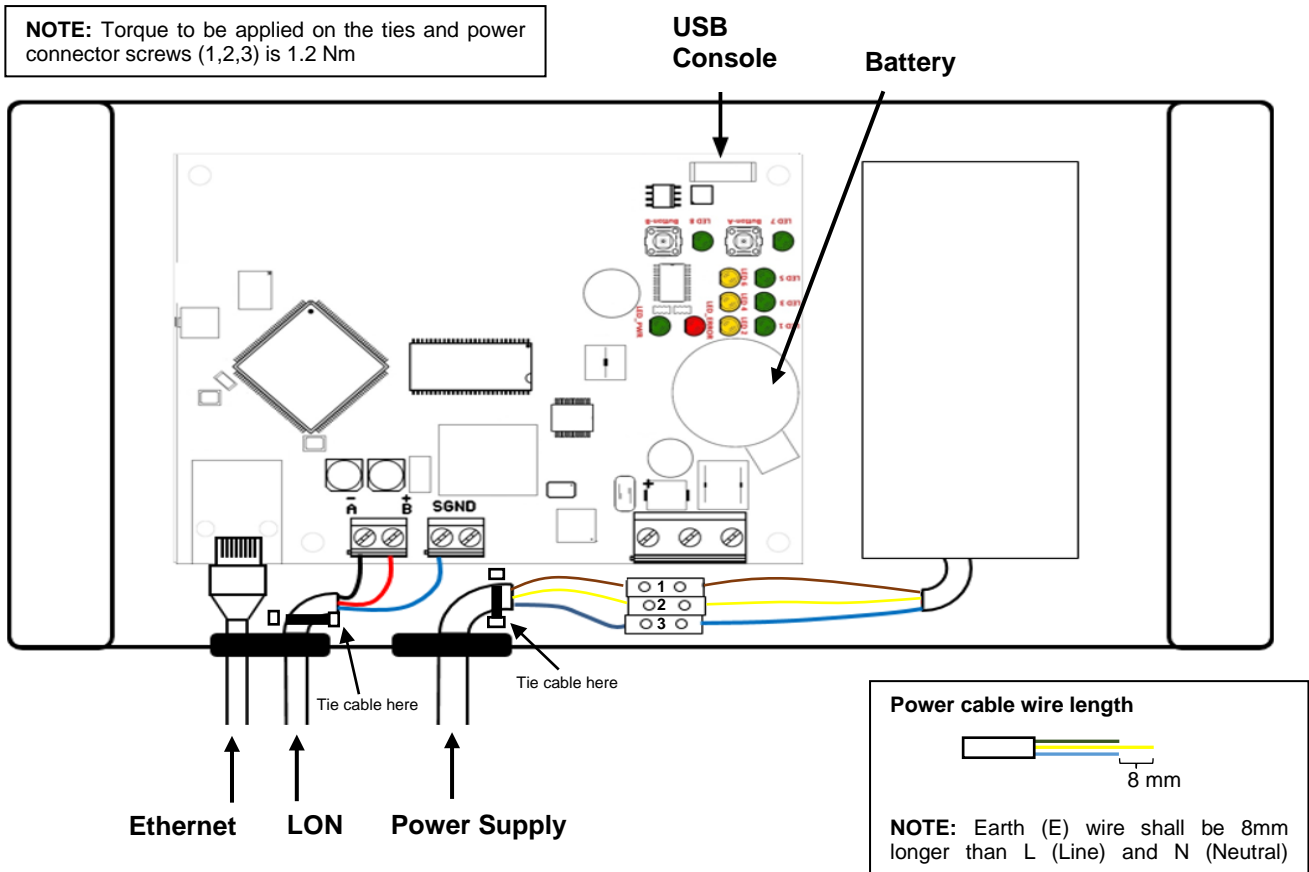

Figure 6.1 Gateway connections

NOTE: Mount the device in a vertical position and ensure proper space for all connectors when mounted. Product is to be connected only to Ethernet and LON networks without routing to the outside plant and connect to outdoor devices through SELV ports.

CAUTION

Risk of explosion if battery is replaced by an incorrect type. Dispose of used batteries according to the instructions.

IMPORTANT: Tie the power supply and the LON cable to the corresponding tie fixture as shown in Figure 6.1. When doing so, cable must be tied thru only one of the 2 holes of the tie fixture. If cable is tied thru both of the 2 holes of the tie fixture, the cable may become loose and can be dangerous.

Power Supply

Connect mains to the power supply connector as:

- 1.- Brown: Line (L)
- 2.- Yellow: Earth / Ground (E)
- 3.- Blue: Neutral (N)

A readily accessible disconnect device shall be incorporated in the building installation wiring.

Ethernet / BACnet IP (UDP) / Console (UDP & TCP)

Connect the cable coming from the IP network to the connector ETH of the gateway. Use an Ethernet CAT5 cable.

VRF Network

Connect the LON bus to connectors A3 (+), A4 (-) and A1/A2 (SNGD) of gateway's PCB. There are no polarities for the A3 (+), A4 (-) signals.

Console Port

Connect a mini-type B USB cable from your computer to the gateway to allow communication between the Configuration Software and the gateway. Remember that Ethernet connection is also allowed for configuration.

6.2 Wiring Requirements & Notes

6.2.1 Electrical Requirement

Use	Size		Wire type	Remarks
Power supply cable	Maximum	1.25 mm ² (16AWG)	Type 60245 IEC 57 or equivalent	1Ø AC208–240 V 50/60Hz, 2 Cable + earth (ground) [Always earth (ground) the unit]
	Minimum	0.5 mm ² (20AWG)		
Transmission cable	0.33 mm ² (22AWG)		22AWG LEVEL4 (NEMA) nonpolar 2 core, twisted pair solid core Shielded	LONWORKS® compatible cable
Ethernet cable			Category 5 or Higher STP cable with RJ45 connector	Ethernet cable
Fuse capacity	1.25 A			

WARNING

Before starting installation work, turn off the power of this unit and the connection destination. Do not turn on the power again until installation is completed. Otherwise, it will cause electric shock or fire.

Use specified cables or accessory cables to connect to this unit.

Do not modify the cables to connect this unit other than those specified, do not use extension cables, and do not use independent branch wiring. It may cause electric shock or fire.

Install the transmission cables securely to the terminal block. Confirm that external force is not applied to the cable. Use transmission cables made of the specified cable. If intermediate connection or insertion fixing are imperfect, it will cause electric shock, fire, etc.

When connecting the cables to this unit, route the cables so that the cover of this unit is securely fixed. If the cover is imperfectly fixed, it may cause fire or overheating of the terminals.

Perform earth (ground) work positively. Do not connect the earth (ground) cable to a telephone cable, water pipe, or conductor rod.

Always fasten the outside covering of the cables with the cable clamp. (If the insulator is chafed, electric leakage may occur.)

Perform all wiring works so that the user does not touch the wiring. Otherwise, injury or electric shock could result.

If any cable is damaged, do not repair or modify it yourself. Improper work will cause electric shock or fire.

CAUTION

Do not bind the remote controller cable and the transmission cable together with or parallel to the power supply cable of the indoor and outdoor units. It may cause erroneous operation.

When performing wiring work, be careful not to damage the cable or injure yourself. Also, connect the connectors securely. Loose connectors will cause trouble, heating, fire, or electric shock.

Install the indoor and outdoor units, power supply cable, transmission cable and remote control cable 1 m (40 in.) away from television and radio to avoid distorted images and noise. Otherwise, a malfunction could result.

Perform wiring so that water does not enter this unit along the external wiring. Always install a trap to the wiring or take other countermeasures. Otherwise it will cause trouble or electric shock or fire.

Confirm the name of each unit and name of each terminal block of the unit and connect the wiring in accordance with the directions given in the manual so that there is no incorrect wiring. Incorrect wiring will damage the electric parts and cause smoke and fire.

When installing the connection cables near a source of electromagnetic waves, use shielded cable. Otherwise, a breakdown or malfunction could result.

The terminal screws and earth (ground) screws have different shapes. Be sure to install the screws in the correct locations. If the screws are installed in the wrong locations, the circuit board could be damaged.

Note:

- Do not bind the power supply cable and transmission cable to avoid an erroneous operation.
- Use shield cable for transmission cable. The shield metal should be earthed (grounded).
- Install the disconnect switch to the easily accessible location.
- Check that an appropriate fuse (1.25A) is set.
- Before connecting cables, turn off the power of the VRF units connected to the gateway.

6.3 Power device

The first step to perform is to power up the device. To do so, a power supply working with any of the voltage range allowed is needed (check section 10). Once connected the ON led will turn on.

Notes:

- (1) Connect the cables to the correct terminals. Take care that the cables do not get shortened. The stripped end of the cables are preferably be tinned.
- (2) Secure the cable to the terminals using an appropriate tool so that the cables do not come loose.
- (3) Use the specified cables, connect them securely, and fasten them so that there is not stress placed on the terminals.
- (4) Use an appropriate screwdriver to tighten the terminal screws.
Do not use a screw driver that is too small or big. Otherwise, the screw heads may be damaged and prevent the screw from being properly tightened.
- (5) Do not tighten the terminal screw too much. Otherwise, the screw may break.
- (6) Apply an appropriate tightening torques for the terminal screw. Otherwise, abnormal overheating may occur and possibly cause heavy damage inside the unit,.
- (7) Do not fix 2 or more power supply cables with 1 screw/terminal.

WARNING

Apply an appropriate tightening torques for the terminal screw. Otherwise, abnormal overheating may occur and possibly cause heavy damage inside the unit,.

CAUTION

Check that the power supply voltage is within the specified range. If the power supply voltage outside the specification is input, it will cause trouble.

Recheck the wiring. Incorrect wiring will cause trouble.

6.4 Connect to BACnet

Connect the communication cable coming from the network hub or switch to the Ethernet port (Figure above) of the gateway. The cable to be used depends on where the gateway is connected:

- Connecting directly to a BACnet/IP device: a straight Ethernet UTP/STP CAT5 cable
- Connecting to a hub or switch of the LAN of the building: a straight Ethernet UTP/STP CAT5 cable

In case there is no response from the BACnet devices to the frames sent by gateway, check that they are operative and reachable from the network connection used by the gateway. Check the gateway Ethernet interface sending Pings to its IP address using a PC connected to the same Ethernet IP network. If the problem persists communicating through the LAN of the building, contact the network administrator and make sure traffic on the port used is allowed through all the LAN path.

The BACnet Gateway for VRF System comes with DHCP functionality enabled by default.

6.5 Connect to Fujitsu interface

Use the LON connector in the left bottom corner of the gateway in order to connect the VRF network to the UTY-VBGX. Remember to follow all safety precautions indicated by Fujitsu.

Modifying some other parameters can affect proper communication.

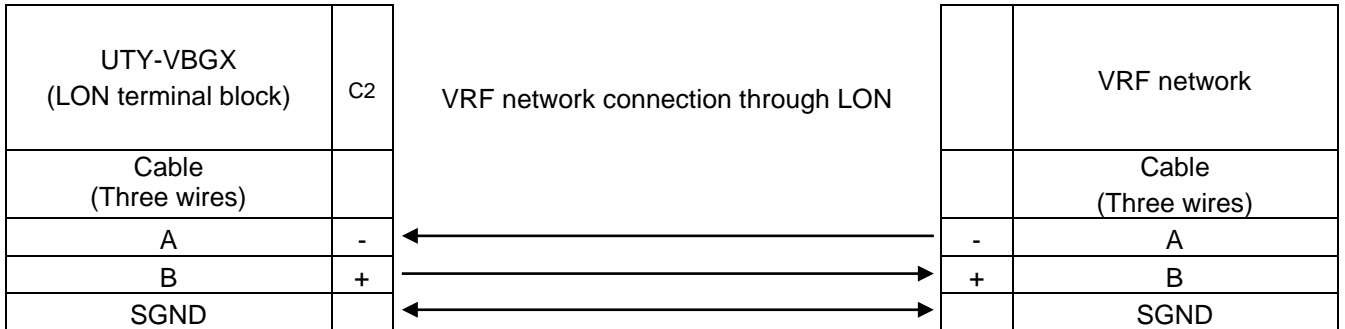

NOTE: Torque to be applied on the LON connector screws (A,B,SGND) is 0.5 Nm

⚠ WARNING
Tighten the terminal screws to the specified torques, otherwise, abnormal overheating may occur and possibly cause heavy damage inside the unit.

⚠ CAUTION
<ul style="list-style-type: none"> To peel the sheath from the lead cable, use a dedicated tool that will not damage the conductor cable. When installing a screw on the terminal block, do not cut the cable by overtightening the screw. On the other hand, under tightened screw can cause faulty contact, which will lead to a communication failure.

6.6 Connect to PC (Configuration tool)

This action allows the user to have access to configuration and monitoring of the device. Two methods to connect to the PC can be used:

- Ethernet: Using the ETH port of the gateway. How to check connectivity is explained in section 6.3.
- USB cable: To connect the device to the PC the USB cable supplied should be plugged to the USB Console port.

7 Set-up process and troubleshooting

7.1 Pre-requisites

It is necessary to have the BACnet/IP client device (BMS side device) operative and properly connected to the BACnet/IP port of the gateway. It is also required to have the VRF network connected to the gateway through LON wiring as defined by the standard.

Connectors, connection cables, PC for the Configuration Tool usage and other auxiliary material, if needed, are not supplied by FGL for this standard integration.

Items supplied with this product for this integration are:

- BACnet Gateway for VRF device with firmware loaded.
- Configuration Tool to configure the BACnet Gateway for VRF.
- USB Console cable to communicate with the BACnet Gateway for VRF.
- Product documentation.

7.2 Set-up procedure

1. Install the Configuration Tool in your laptop, use the setup program supplied in the USB memory stick supplied with this product and follow the instructions given by the installation wizard.
2. Install the gateway in the desired installation site. The mounting can be on a stable not vibrating surface. The direction of the mounting of the case must be such that there are no cable opening towards the bottom side.
3. Connect the communication cable coming from the BACnet/IP network to the port marked as **Ethernet** of the gateway (More details in section 6.3).
4. Connect the communication cable coming from the FGL bus to the port marked as **AB SGND** of the gateway (More details in section 6.5).
5. Power up the gateway. Take care of the polarity of the supply voltage applied (More details in section 6.5).
6. Connect your laptop or desktop to the gateway (More details in section 6.6).
7. Open the Configuration Tool, create a new project. Select the connection mode to be used to connect to the gateway and click on the **Connect** button. Configuration Tool can be started from the startup menu under the folder "AIRSTAGE", selecting "BACnet Gateway Hardware".
8. Modify the configuration as desired, save it and download the configuration file to the gateway (More details in section 8).
9. Open the *BACnet Communication Viewer* window and check that there is communication activity, some TX frames and some other RX frames. This means that the communication with the BACnet master device is OK. In case there is no communication activity between the gateway and the BACnet device check that it is operative and the communication cable used to connect both devices.
10. Open the *Fujitsu Communication Viewer* window and check that there is communication activity, some RX frames. This means that the communication with the VRF network is OK. In case of no communication activity, check that the VRF network is operative and well configured and check also the communication cable used to connect both systems.

7.3 LEDs status and push buttons

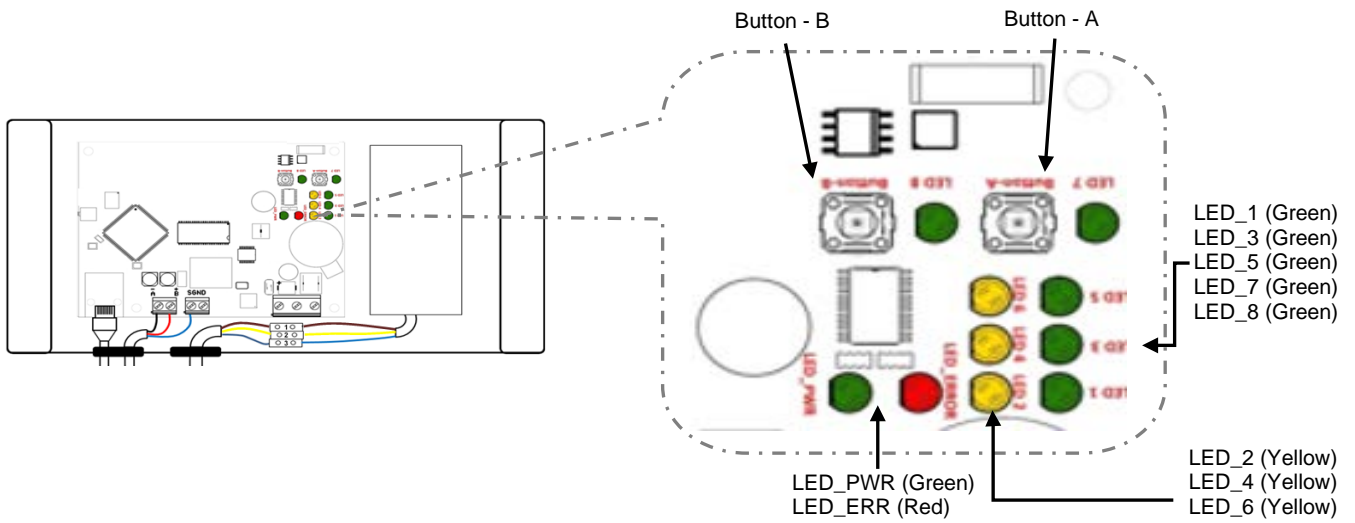

LED	Description
LED_ERR (red)	Gateway error state indication. If active, contact your supplier.
LED_PWR (green)	Power-on. HW-controlled / non-FW.
LED_1 (green)	Ethernet LNK led. Same as Ethernet green led.
LED_2 (yellow)	Ethernet ACT led. Same as Ethernet yellow led.
LED_3 (green)	Fujitsu bus TX activity.
LED_4 (yellow)	Fujitsu bus RX activity.
LED_5 (green)	BACnet TX LED.
LED_6 (yellow)	BACnet RX LED.
LED_7 (green)	Service led of LON port.
LED_8 (green)	Device has IP address (after DHCP or manually assigned).

Button	Description
PUSH_A	Sends I-Am msg on bacnet-ip side.
PUSH_B	Service pin of LON port.

8 Configuration Tool for BACnet Gateway (UTY-VBGX)

8.1 Introduction

The Configuration Tool for BACnet Gateway is a Windows® 7/ 8.1/ 10 compatible software developed specifically to monitor and configure the UTY-VBGX gateway.

In order to install the software, simply execute the installer within the USB memory stick supplied with this product and follow instructions on the wizard.

Note: Screen design described in the following chapters may slightly change depending on the version of the software.

8.2 Welcome screen

From the welcome screen, access is granted to: the Fujitsu General Limited Website, start a new project, load a previous project from our computer or get the current project running on the gateway.

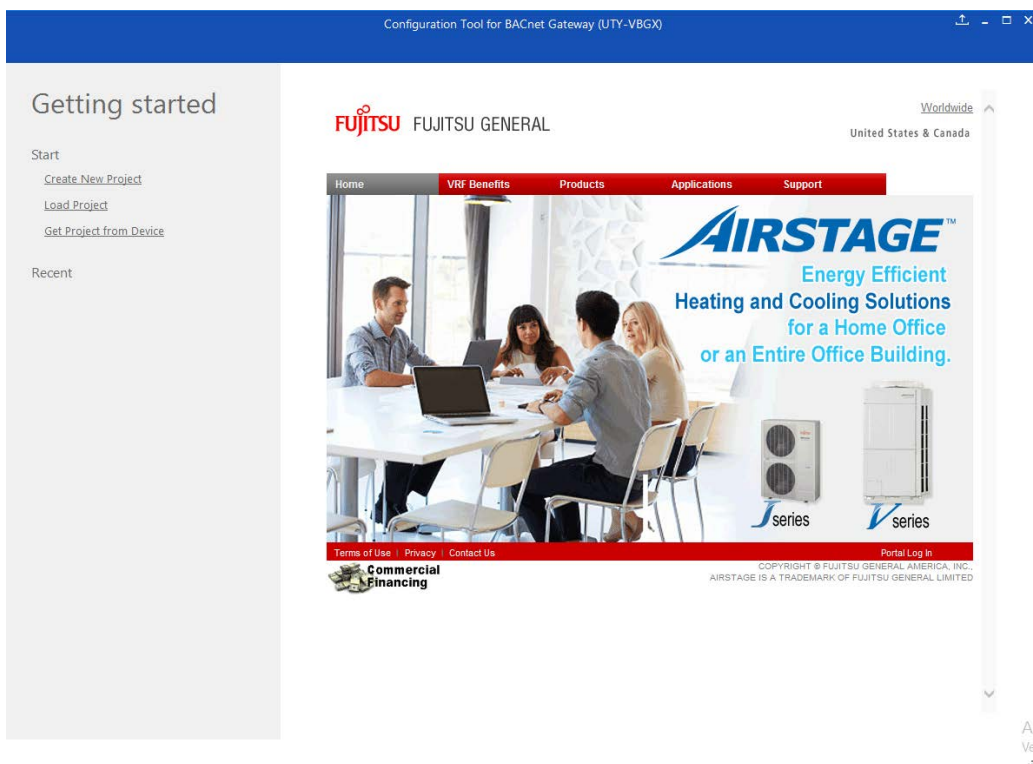

Figure 8.1 Welcome screen

1. Create New Project

When pressing this button, you will be directed to the connection view. More information can be found in 8.3

2. Load Project

Use this option to select a previous project you have been working with and it is already stored in your PC or an accessible storage device.

3. Get Project from Device

Use this option to get the current configuration running on the gateway. Notice that to do that, you need to be connected to the gateway.

- **IP connection:** This requires Ethernet connection to the gateway and also knowing the connection password. More information about the password can be found in section 8.4.1.
- **USB connection:** This requires USB connection to the gateway.

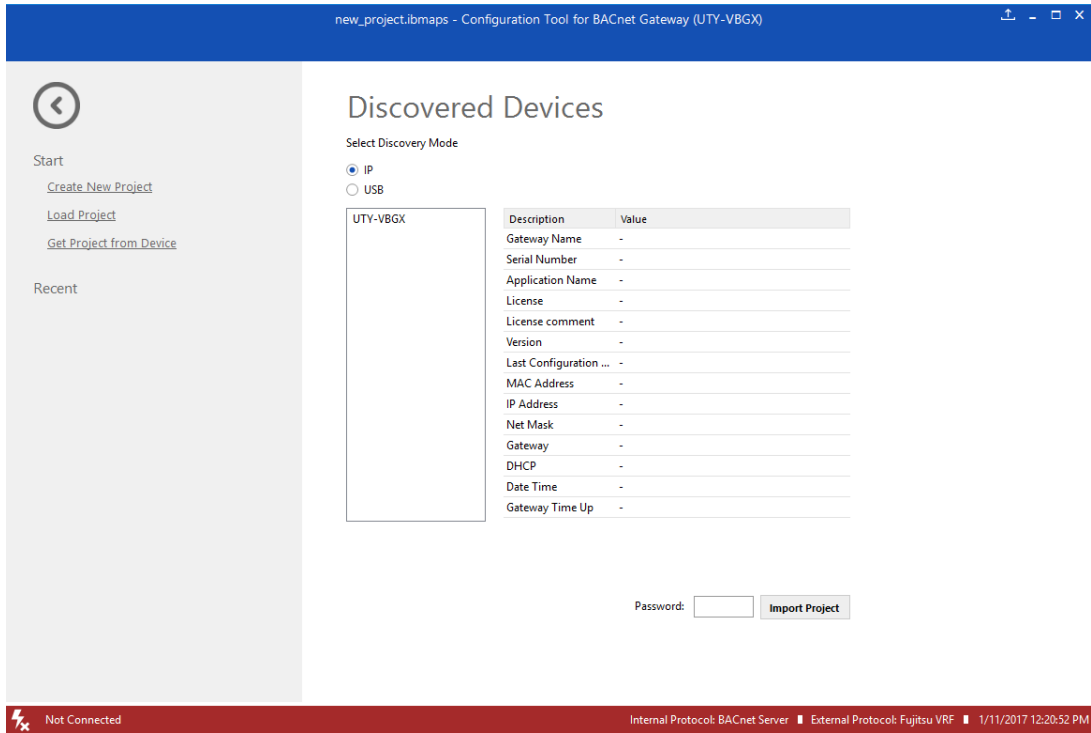

Figure 8.2 Get Project from Device view

8.3 Connection

Use this section to configure the connection between the laptop or desktop to the gateway.

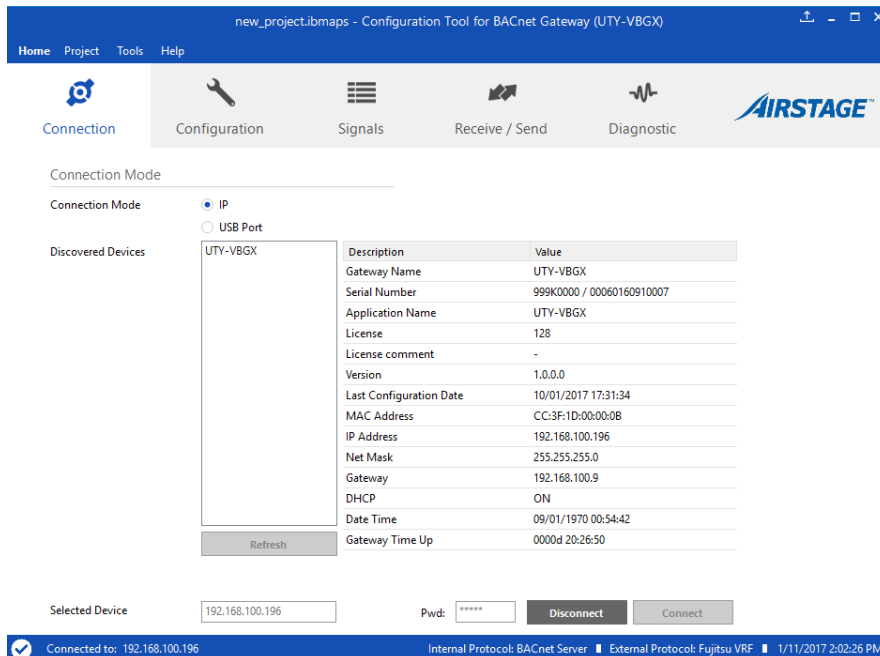

Figure 8.3 Connection configuration

NOTE: If using IP connection, the Configuration Tool will automatically scan the IP network for the gateway and will show it in the list. Notice that in that case, a password is required. Default values for IP connection are: **IP: 192.168.100.246 / Password: admin**
If installing more than one BACnet Gateway for VRF System, connect them one by one and assign an IP to each of them in case DHCP is not available.

8.4 Configuration

In this section is where main configuration for the signals is carried out.

8.4.1 General

Set the general gateway parameters.

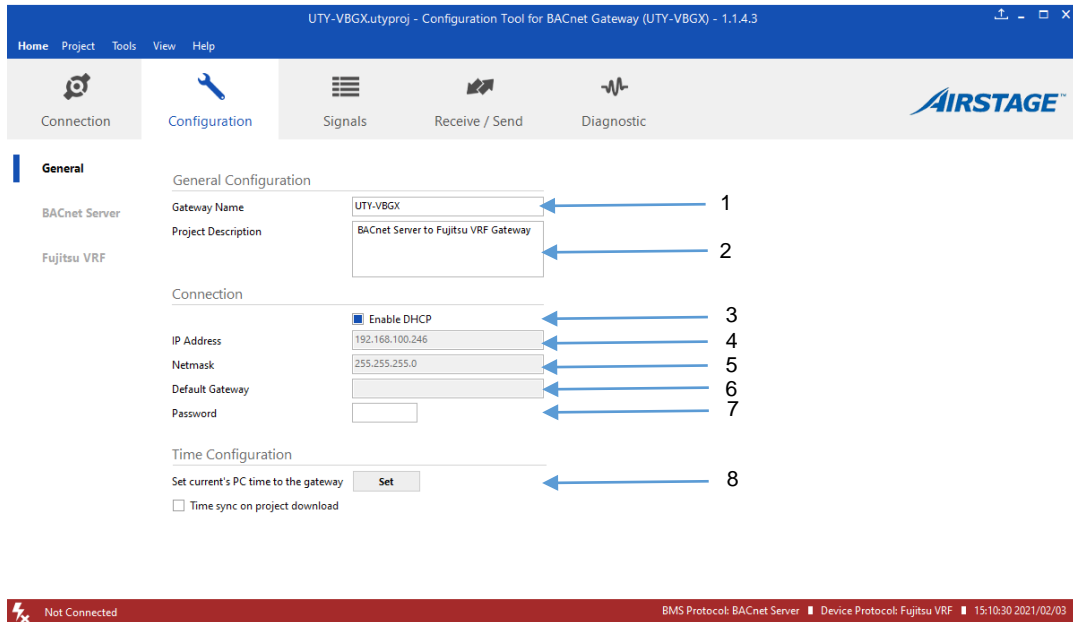

Figure 8.4 General configuration

1. **Gateway Name:** Descriptive name for the gateway in its use on the Configuration Tool.
2. **Project Description:** Short description of the project.
3. **Enable DHCP:** Enables and disables DHCP usage by the gateway.
4. **IP:** Enter the IP address for the gateway (**192.168.100.246** by default).
5. **NetMask:** Enter the gateway net mask address (**255.255.255.0** by default).
6. **Gateway:** Enter the router or default gateway address if needed. In case you don't want to use it, leave it blank.
7. **Password:** Enter the access password to allow IP connection to the gateway (**admin** by default).
8. **Time:** Press "Set" set current PC time to the gateway. Check "Time sync on project download" to synchronise time when downloading project to the gateway.
9. Security configuration if exists, is for maintenance purpose only, and is not to be edited.

8.4.2 BACnet Server

Set the BACnet parameters

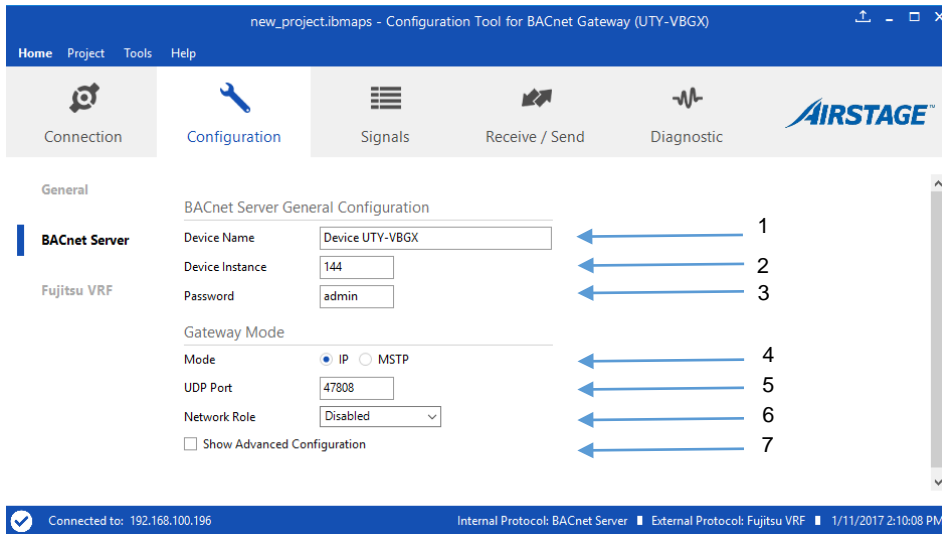

Figure 8.5 BACnet/IP interface configuration

1. **Device Name:** Device BACnet name and description (*Device UTY-VBGX* by default).
2. **Device Instance:** Device BACnet number (*144* by default, if more than one UTY-VBGX is present, this have to be a unique number for each BACnet Gateway for VRF System).
3. **Password:** Password to allow IP connection (*admin* by default).
4. **Mode:** BACnet IP mode is the only one available.
5. **UDP Port:** Used port for BACnet IP communications (*47808* by default)
6. **Network Role:** Select the gateway role from a BACnet network device point of view:
 - a. **Disabled**
 - b. **Foreign device**
 - c. **BBMD**
7. **Show advanced configuration:** Enables Notification Classes configuration.

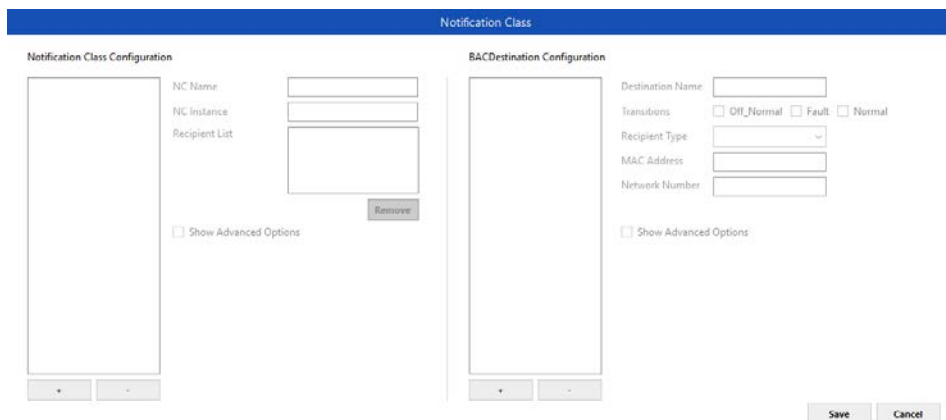

Figure 8.6 Notification Class configuration

Assign the Notification Class added here to objects in the Signal tab .

8.4.3 Fujitsu VRF

Set the Fujitsu VRF parameters

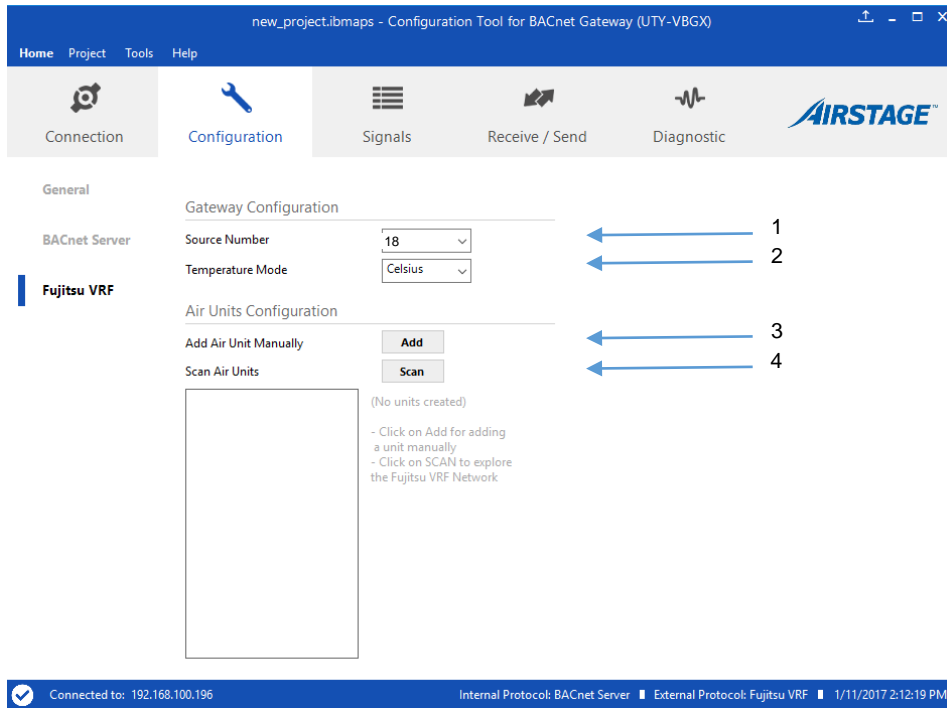

Figure 8.7 Fujitsu VRF interface configuration

- 1. Source Number:** Enter the BACnet gateway LON address (values from 3 to 18), with no address duplication between other units/products within the same VRF network).

Note: The address numberings are different between products. Following table should be taken into consideration to avoid duplication between products.

Conversion Table	BACnet Gateway (UTY-VBGX) Niagara Driver for VRF	UTY-DTG_Z1, UTY-DCG_Z1 UTY-VMGX, UTY-VKGX, etc.
Settings (Screen, DIP-SW)	3 - 18	0 - 15
LON address	3 - 18	Add 3 to above

IMPORTANT: In order for the source number to take effect, the settings must be sent to the unit even before performing scan, as described in section 8.6.

- 2. Temperature Mode:** Enter the desired temperature units to be used (Celsius or Fahrenheit).
- 3. Add Air Unit Manually:** Use this option to introduce units manually in the configuration.

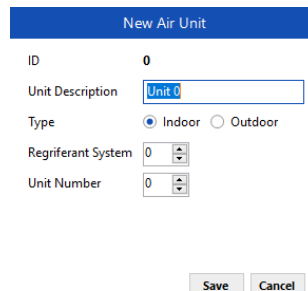

Figure 8.8 Add units manually

4. Scan Air Units:

Use this function to scan the VRF network automatically to look for the current units connected to the system.

Note: Scan may take from 5 to 6 minutes depending on each installation specs.

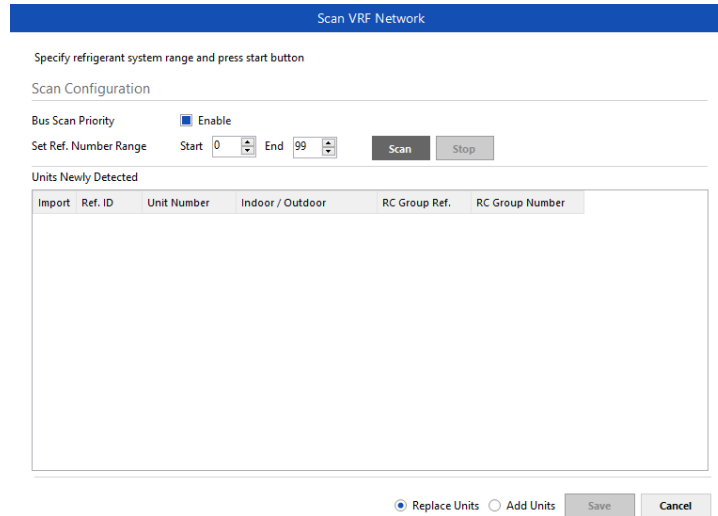

Figure 8.9 Units scan on the FGL bus

8.5 Signals

Check the current available signals according to the units configured on the configuration tab (see section 8.4.3).

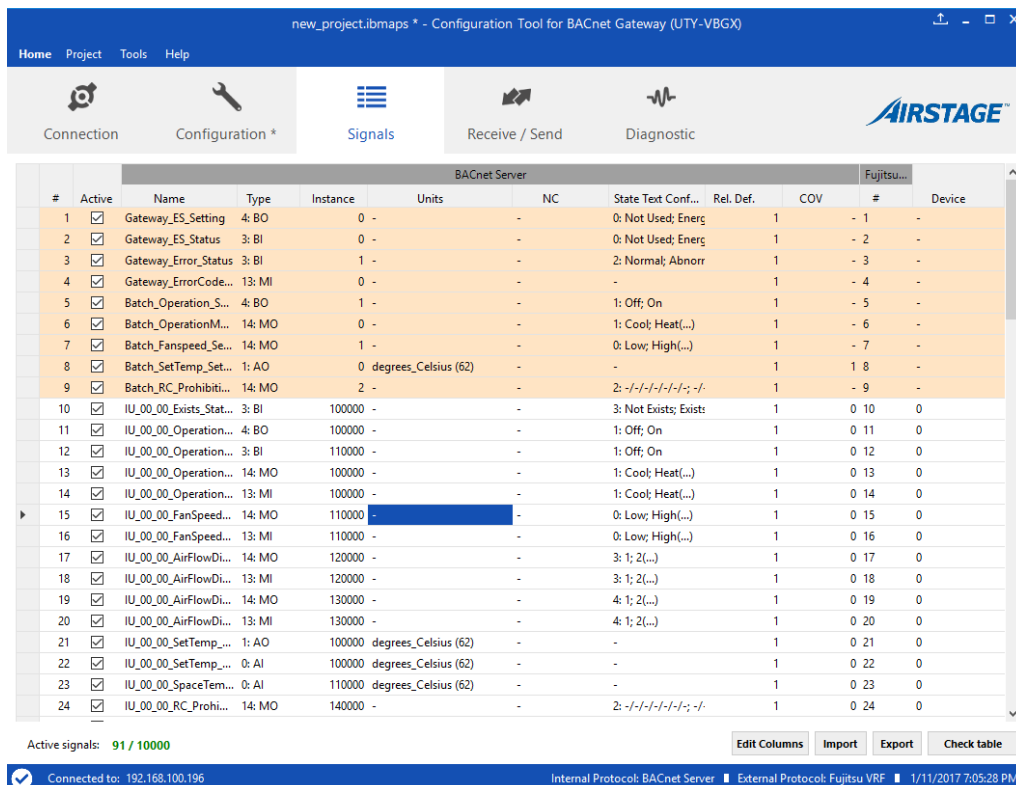

Figure 8.10 Signals' Viewer

1. **Signal number:** Configuration Tool internal reference.
2. **Active:** Indicates if the signal is currently active for this configuration. If not, it will not be considered by the tool when downloading it to the gateway.

3. **Object BACnet name:** Signal's descriptive name that identifies the signal.
 4. **BACnet type:** Type of BACnet object.
 5. **Object Instance:** BACnet object instance. This can be a fixed number or a formula for the identification of each element.
 6. **Units:** Units applied to each object.
 7. **NC:** Notification Class. Set the Notification Class added in the Cofiguration tab.
 8. **State text configuration:** Enums the State text to be shown.
 9. **Relinquish default value:** Indicates the current relinquish default value for this object.
 10. **COV:** Sets the COV increment value for this object.
 11. **#:** Internal gateway address for each register.
 12. **Device:** FGL device number associated to this register.
- a) **Edit Columns:** Enables or disables visible columns.
 - b) **Export:** Exports the current configuration.
 - c) **Check table:** Checks the current configuration to make sure.

Some of the columns above need to be enabled to be shown. Click “Edit columns” to enable.

8.6 Receive/Send

Send or receive the current configuration of the gateway.

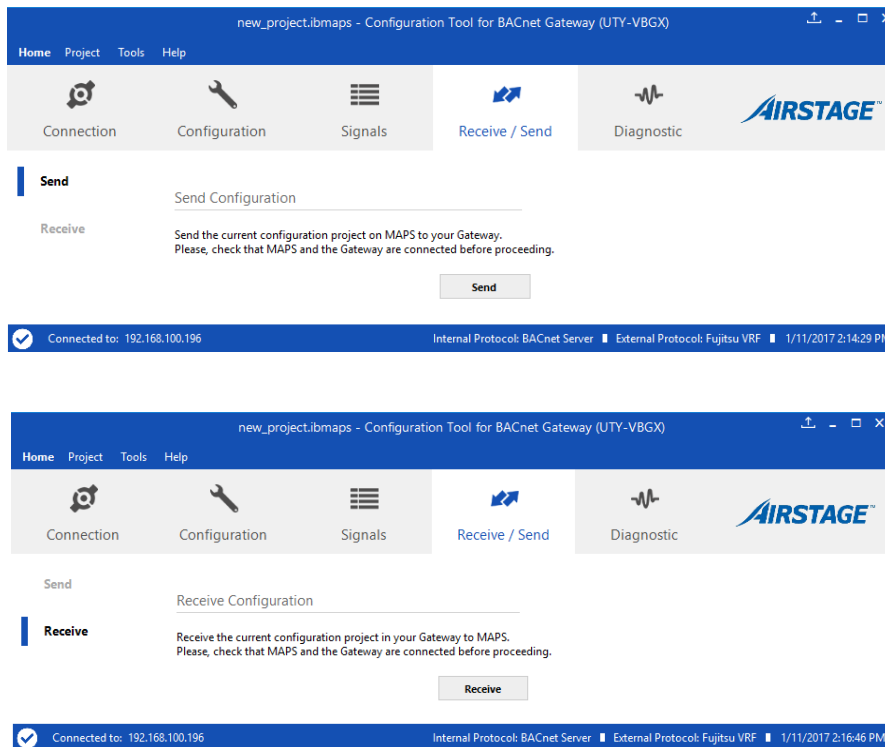

Figure 8.11 Send and receive options

IMPORTANT: It is required that the ethernet link of this gateway is established and active, in order to send and configure the IP addresses. Otherwise, IP addresses will not be set by the "Send".

8.7 Diagnostic

Use this setting to check the current communication status of the gateway on both: BACnet and FGL.

Communication with the box, the BACnet side and the Fujitsu system can be check using the viewer available.

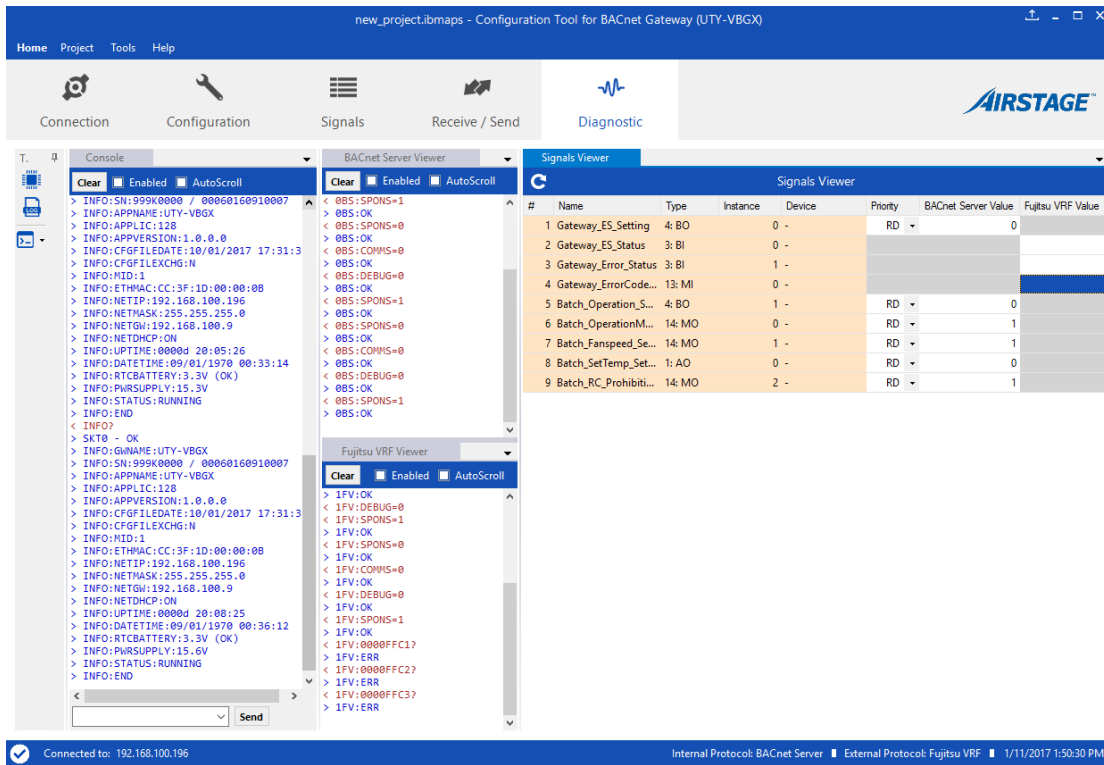

Figure 8.12 Diagnostic tool

- 1. Hardware Test:** Checks the current hardware status of the gateway to ensure that is not faulty.
- 2. Log:** Enables the LOG Record Mode which starts logging communications from all viewers and stores it in a zip file. This file can be sent directly to the support team to check any unexpected behavior of the gateway.
- 3. Commands:** It sends specific commands to the gateway to perform general actions. It is for maintenance purpose only.
 - **INFO?** Asks the gateway to identify itself and show basic information.
 - **RESET!** Resets the gateway. This is not a back to factory settings action.
 - **Enable COMMS** Enables communication between the gateway and the Configuration Tool
 - **Disable COMMS** Disables communication between the gateway and the Configuration Tool

8.7.1 Console

Shows basic information about the gateway and communication between BACnet and VRF systems. This is for Fujitsu internal maintenance purpose only.

8.7.2 BACnet Server Viewer

Shows specific information about the BACnet communication. This is for Fujitsu internal maintenance purpose only.

8.7.3 Fujitsu VRF Viewer

Shows specific information about the VRF network communication. This is for Fujitsu internal maintenance purpose only.

8.7.4 Signals Viewer

Check the current signal values on both: BACnet and VRF network side (connection to the VRF network and/or BACnet client is required).

The Signals Viewer can be used even though only one system is connected to the gateway, BACnet or Fujitsu AC. Therefore, it becomes convenient for supervision and testing the system.

In order to force a specific value to a signal, double-click the corresponding **BACnet Server Value** or **Fujitsu VRF Value** cell in the table. Notice that grey cells can't be read or written. Changing its value in this way, will make:

- The content of the corresponding object will be changed to this value.
- If the signal is write-enabled, it will trigger a suitable command to Fujitsu AC system.

9 AC Unit Types compatibility

VRF Gateway for VRF System is compatible with units that are later than V-II series.

10 Mechanical & electrical characteristics

Enclosure	Material: Plastic, type PC (UL 94 V-0) Dimensions: 270mm x 176mm x 60mm Weight: 1.2 Kg Color: Light Grey RAL 7035
Mounting	Wall recommended
Power	Screw terminal block for power connection (3 poles) 208 to 240VAC 50 to 60Hz 4.6W max.
Terminal wiring Power supply and low-voltage signals	Per terminal: solid wires or stranded wires (twisted or with ferrule) 1 core: 0.5 ... 2.5mm ² 2 cores: 0.5 ... 1.5mm ² 3 cores: not permitted
Ethernet port	Connector: RJ45 for shielded cat5 or higher class cable Communication speed: 10/100 Mbps Communicates with: BACnet IP network PC for gateway configuration
Port A LON	A1 A2 (2 poles screw terminal) Signal Ground A3 A4 (2 poles screw terminal) Fujitsu VRF network connection
USB port	Mini Type-B receptacle connector and USB 2.0 compliant Only for gateway configuration and diagnostic 1500VDC isolation from others ports
Battery	Size: Coin 20mm x 3.2mm Capacity: 3V / 225mAh Type: Manganese Dioxide Lithium
LED indicators	1 x Power 1 x Error
Operational temperature	0°C to +46°C
Operational humidity	5% to 95%, non-condensing
Preservation Temperature	-10°C to +60°C
Protection	IP20 (IEC60529).
RoHS conformity	Compliant with RoHS directive (2002/95/CE).

11 Dimensions

[mm]

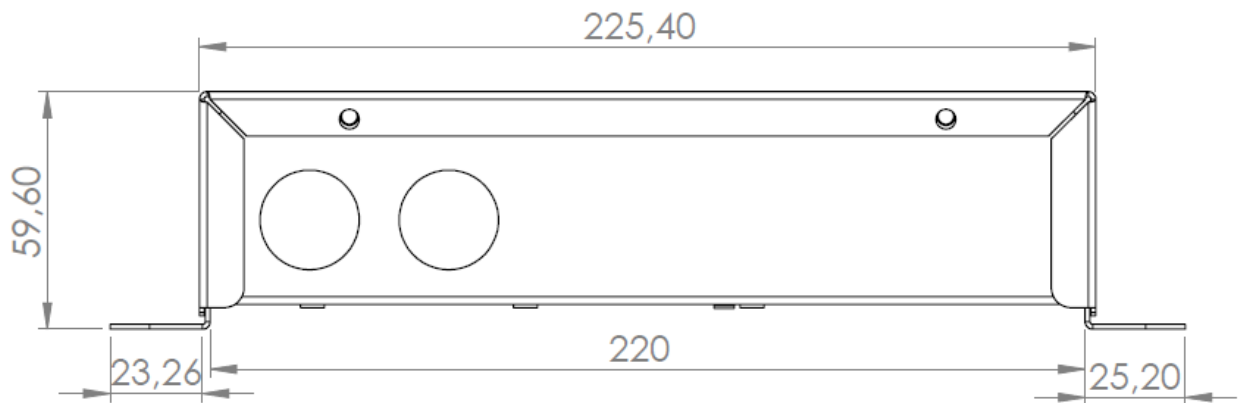
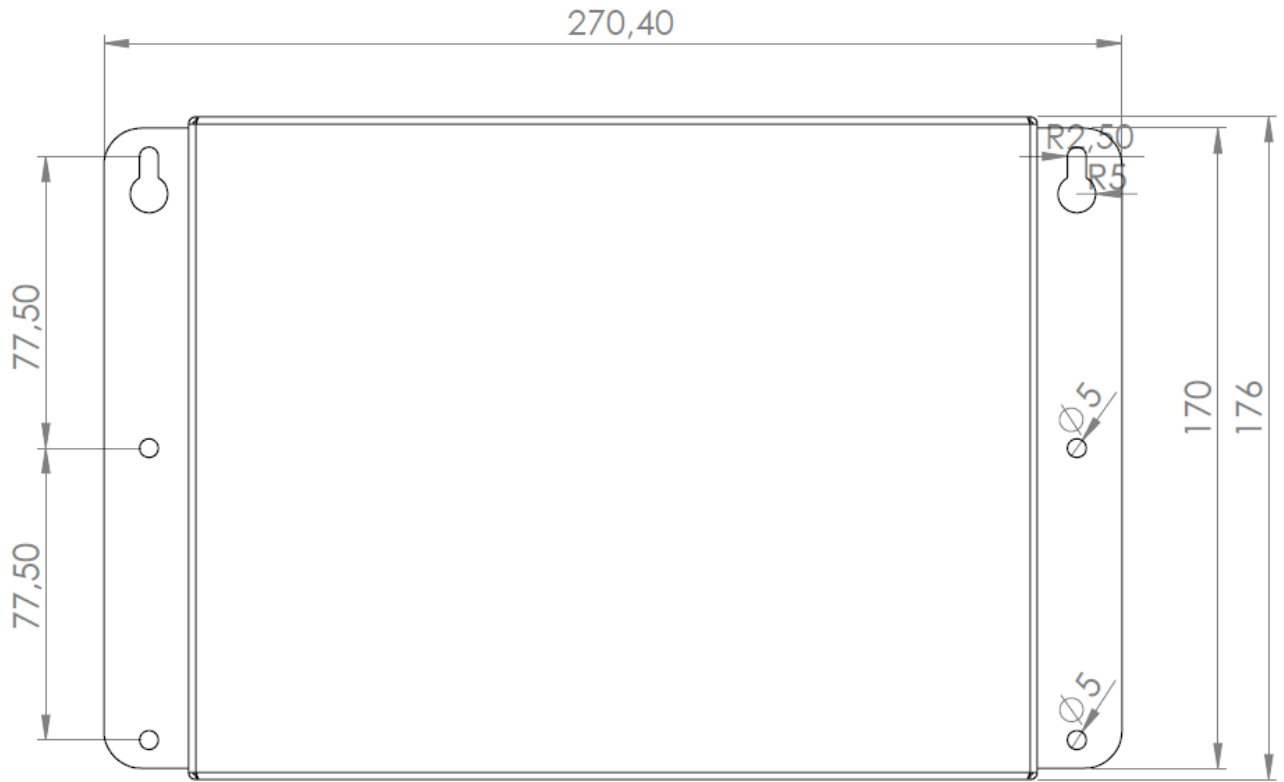

12 Annex

12.1 Error codes

Below you can find a list of error codes from Fujitsu air conditioning system.

V-II or laterf Series

Present_Value	Error Code	Error Description
17	11	Serial communication error between indoor/outdoor units
18	12	Remote controller communication error
19	13	Communication error between Outdoor unit
20	14	Network communication error
21	15	Scan error
22	16	Peripheral device communication error
23	17	Electricity charge apportionment error
24	18	External communication error
33	21	Initial setting error
34	22	Indoor unit capacity abnormal
35	23	Incompatible series connection error
36	24	Connection unit number error
37	25	Connection pipe length error
38	26	Address setting error
39	27	Master unit, slave unit set-up error
40	28	Other setting error
41	29	Connection unit number error in wired remote controller system
49	31	Indoor unit power supply abnormal
50	32	Indoor unit main PCB error
51	33	Indoor unit extensions microcomputers error
52	34	Power relay error
53	35	Indoor unit manual auto switch error
54	36	Heater relay error
55	37	Indoor unit transmission PCB error
56	38	Network convertor PCB error
57	39	Indoor unit power supply circuit error
58	3A	Indoor unit communication circuit (wired remote controller) error
65	41	Indoor unit room temp. thermistor error
66	42	Indoor unit heat ex. temp. thermistor error
67	43	Humidity sensor error
68	44	Light sensor error
69	45	Gas sensor error
70	46	Float sensor error
71	47	Water temperature sensor error
72	48	Warm water flow rate sensor error
73	49	Heater sensor error
74	4A	Indoor unit air temp. thermistor error
81	51	Indoor unit fan motor 1 error
82	52	Indoor unit coil (expansion valve) error
83	53	Indoor unit water drain abnormal
84	54	Air cleaning function error
85	55	Filter cleaning function error
86	56	Water circulation pump error

87	57	Indoor unit damper error
88	58	Indoor unit intake grille position error
89	59	Indoor unit fan motor 2 error
90	5A	Indoor unit fan motor 3 error
95	5U	Indoor unit miscellaneous error
97	61	Outdoor unit power supply abnormal
98	62	Outdoor unit main PCB error
99	63	Outdoor unit inverter PCB error
100	64	Outdoor unit active filter/PFC circuit error
101	65	Outdoor unit IPM error
102	66	Convertor distinction error
103	67	Outdoor unit power short interruption error (protective operation)
104	68	Outdoor unit magnetic relay error
105	69	Outdoor unit transmission PCB error
106	6A	Outdoor unit display PCB error
113	71	Outdoor unit discharge temp. thermistor error
114	72	Outdoor unit compressor temp. thermistor error
115	73	Outdoor unit heat ex. temp. thermistor error
116	74	Outside air temp. thermistor error
117	75	Outdoor unit suction gas temp. thermistor error
118	76	Outdoor unit operating valve thermistor error
119	77	Outdoor unit heat sink temp. thermistor error
120	78	Expansion valve temperature sensor error
129	81	Receiver liquid level detection sensor error
130	82	Outdoor unit sub-cool heat ex. gas temp. thermistor error
131	83	Outdoor unit liquid pipe temp. thermistor error
132	84	Outdoor unit current sensor error
133	85	Fan motor current sensor error
134	86	Outdoor unit pressure sensor error
135	87	Oil sensor error
145	91	Outdoor unit compressor 1 error
146	92	Outdoor unit compressor 2 error
147	93	Outdoor unit compressor start up error
148	94	Outdoor unit trip detection
149	95	Outdoor unit compressor motor control error
150	96	Open loop error(Field-weakening relevant)
151	97	Outdoor unit fan motor 1 error
152	98	Outdoor unit fan motor 2 error
153	99	Outdoor unit 4-way valve error
154	9A	Outdoor unit coil (expansion valve) error
159	9U	Outdoor unit miscellaneous error
161	A1	Outdoor unit discharge temperature 1 error
162	A2	Outdoor unit discharge temperature 2 error
163	A3	Outdoor unit compressor temperature error
164	A4	Outdoor unit pressure error 1
165	A5	Outdoor unit pressure error 2
166	A6	Outdoor unit heat exchanger temperature error
167	A7	Suction temperature abnormal
168	A8	Poor refrigerant circulation
169	A9	Current overload error
170	AA	Outdoor unit special operation error

171	AC	Ambient temperature error
172	AF	Out of the possible operation range
173	AJ	Freeze protection operated
177	C1	Peripheral unit main PCB error
178	C2	Peripheral unit transmission PCB error
179	C3	Peripheral unit PCB 1 error
180	C4	PCB 2 error
181	C5	PCB 3 error
182	C6	PCB 4 error
183	C7	PCB 5 error
184	C8	Peripheral unit input device error
185	C9	Display device error
186	CA	EEPROM error
187	CC	Peripheral unit sensor error
188	CF	Peripheral unit external connector error (USB memory)
189	CJ	Other parts error
193	F1	System tool software error
194	F2	System tool adaptor error
195	F3	System tool interface error
196	F4	System tool environment error
209	J1	RB unit error
210	J2	Branch boxes error
211	J3	Total heat exchanging, ventilation unit error
212	J4	Domestic hot water unit error
213	J5	Zone control interface error
214	J6	DX-Kit error

12.2 RC Prohibition

Remote Control Prohibit commands can be set/read using the values in the following correspondence table.

State Text	Description
FL	Filter display reset operation prohibited
ON	Start operation prohibited (S/V Series do not have this function)
OP	Start/stop operation prohibited
MD	Operation mode operation prohibited
TP	Set temperature operation prohibited
TR	Timer setting prohibited
ALL	All prohibited

Pesent_Value	Contents displayed in State_Text	Pesent_Value	Contents displayed in State_Text
1	-/-/-/-/-/-	34	-/TR/-/-/-/FL
2	-/-/-/-/-/FL	35	-/TR/-/-/-/ON/-
3	-/-/-/-/-/ON/-	36	-/TR/-/-/-/ON/FL
4	-/-/-/-/-/ON/FL	37	-/TR/-/-/OP/-/-
5	-/-/-/-/OP/-/-	38	-/TR/-/-/OP/-/FL
6	-/-/-/-/OP/-/FL	39	-/TR/-/-/OP/ON/-
7	-/-/-/-/OP/ON/-	40	-/TR/-/-/OP/ON/FL
8	-/-/-/-/OP/ON/FL	41	-/TR/-/MD/-/-/-
9	-/-/-/MD/-/-/-	42	-/TR/-/MD/-/-/FL
10	-/-/-/MD/-/-/FL	43	-/TR/-/MD/-/-/ON/-
11	-/-/-/MD/-/-/ON/-	44	-/TR/-/MD/-/-/ON/FL
12	-/-/-/MD/-/-/ON/FL	45	-/TR/-/MD/OP/-/-
13	-/-/-/MD/OP/-/-	46	-/TR/-/MD/OP/-/FL
14	-/-/-/MD/OP/-/FL	47	-/TR/-/MD/OP/ON/-
15	-/-/-/MD/OP/ON/-	48	-/TR/-/MD/OP/ON/FL
16	-/-/-/MD/OP/ON/FL	49	-/TR/TP/-/-/-/-
17	-/-/TP/-/-/-/-	50	-/TR/TP/-/-/-/FL
18	-/-/TP/-/-/-/FL	51	-/TR/TP/-/-/-/ON/-
19	-/-/TP/-/-/-/ON/-	52	-/TR/TP/-/-/-/ON/FL
20	-/-/TP/-/-/ON/FL	53	-/TR/TP/-/OP/-/-
21	-/-/TP/-/OP/-/-	54	-/TR/TP/-/OP/-/FL
22	-/-/TP/-/OP/-/FL	55	-/TR/TP/-/OP/ON/-
23	-/-/TP/-/OP/ON/-	56	-/TR/TP/-/OP/ON/FL
24	-/-/TP/-/OP/ON/FL	57	-/TR/TP/MD/-/-/-
25	-/-/TP/MD/-/-/-	58	-/TR/TP/MD/-/-/FL
26	-/-/TP/MD/-/-/FL	59	-/TR/TP/MD/-/-/ON/-
27	-/-/TP/MD/-/-/ON/-	60	-/TR/TP/MD/-/-/ON/FL
28	-/-/TP/MD/-/-/ON/FL	61	-/TR/TP/MD/OP/-/-
29	-/-/TP/MD/OP/-/-	62	-/TR/TP/MD/OP/-/FL
30	-/-/TP/MD/OP/-/FL	63	-/TR/TP/MD/OP/ON/-
31	-/-/TP/MD/OP/ON/-	64	-/TR/TP/MD/OP/ON/FL
32	-/-/TP/MD/OP/ON/FL	65	ALL/-/-/-/-/-
33	-/TR/-/-/-/-/-		

Note: "ON" and "OP" may not be set at the same time.