



Touch Screen Thermostat

i-70

Owner's manual and technician settings

Index

1. Owner's Manual	4
1.1 Quick Guide	4
1.2 Turning the unit ON or OFF	5
1.3 Adjusting the set-point temperature.....	5
1.4 Switch between temperature scales.....	5
1.5 Switching between System modes	6
1.6 Switching between Fan speeds.....	6
1.7 Fan on demand (Auto fan)	7
1.8 Lock the thermostat's buttons	7
1.9 Timer for turning the thermostat off	7
1.10 Economy mode indications E1 – E5	8
1.11 Freeze protection	9
2. Installation Instructions.....	10
3. Wiring Configuration and DIP Switches.....	13
4. Technician Settings	20
5. MAC Address (MTSC Series only).....	36

1. Owner's manual

1.1 Quick Guide

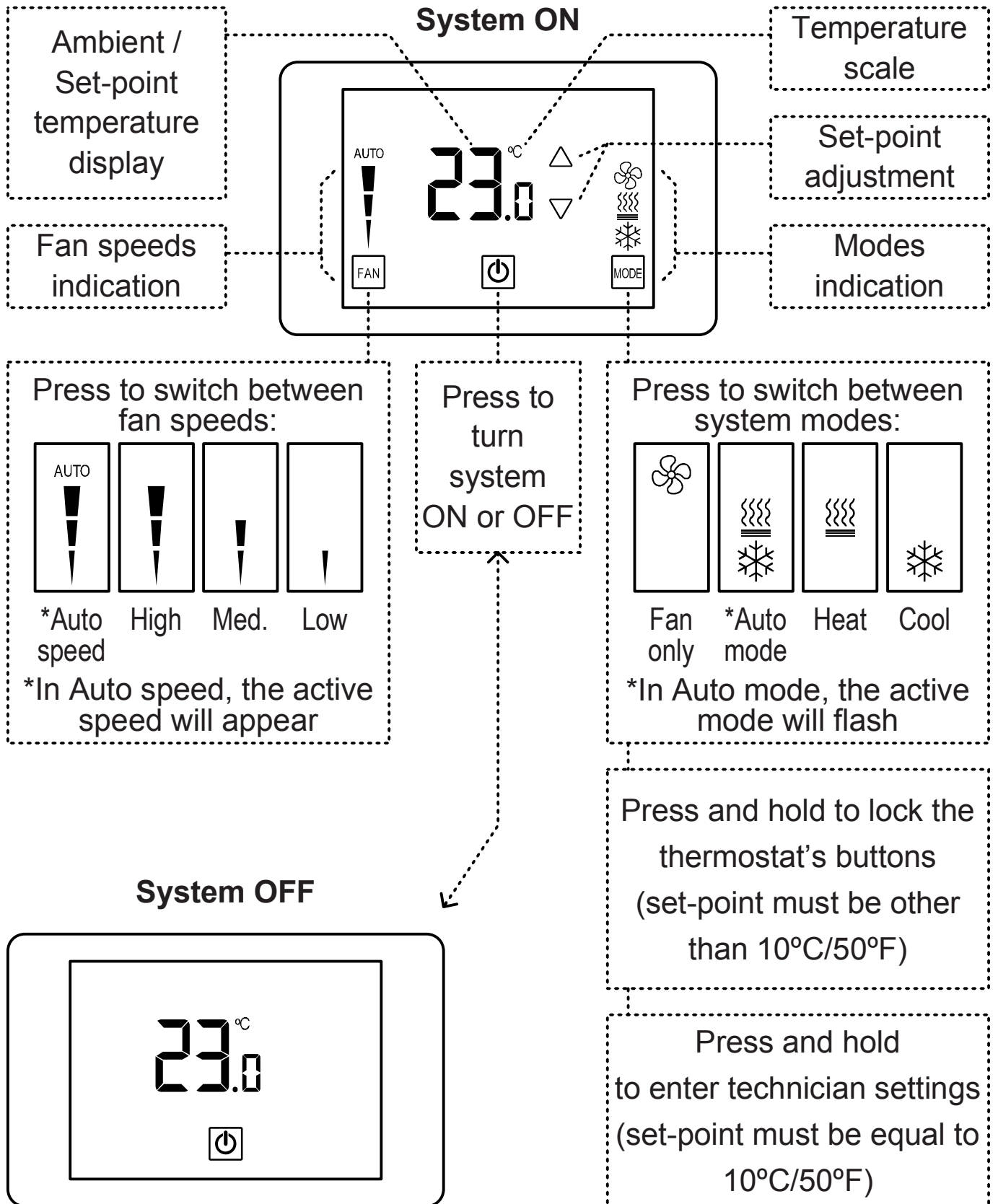

1.2 Turning the unit ON or OFF

- Press the  button to turn the unit ON – system mode and fan speed symbols will appear on display.
- Press again to turn the unit OFF – the symbols will disappear.

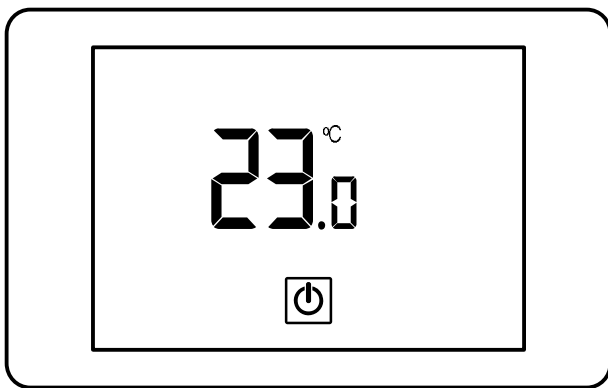

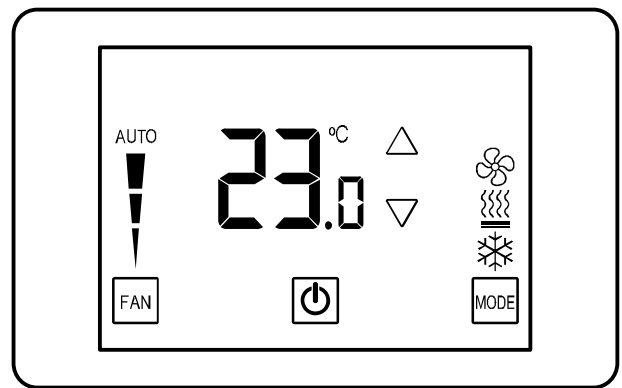

Unit OFF



Unit ON

1.3 Adjusting the set-point temperature

- While the thermostat is ON, press the  or  buttons – the set-point temperature will flash.
- Press again to adjust the set point.

1.4 Switching between temperature scales

- Press and hold the  button to switch between temperature scales.



Note: set-point must be other than 10°C, 11°C/50°F, 51°F

1.5 Switching between system modes

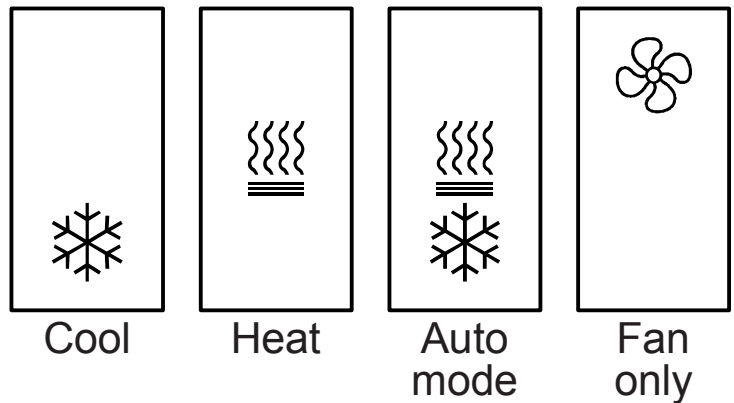
- Press the  button to switch between system modes:



Notes:

- During demand for cooling (cooling active), the  will flash.
- During demand for heating (heating active), the  will flash.

The selection of system modes may be disabled depending on system configuration.

1.6 Switching between fan speeds

- Press the  button to switch between fan speeds:

Note: When Auto speed is selected, the word "AUTO" and the active fan speed will appear on display

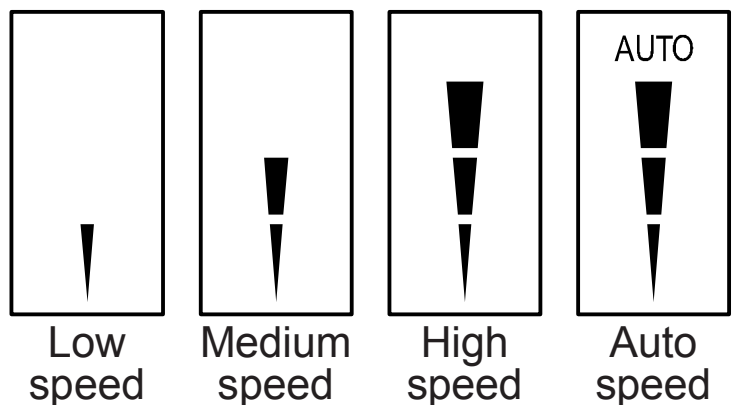

The selection of fan speeds may be disabled depending on system configuration.

1.7 Fan on demand (Auto fan)

- Press and hold the  button to activate or deactivate fan on demand (Auto fan) function.

Notes:

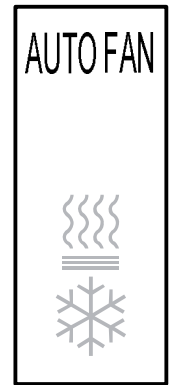

- When activated, the fan will run with demand for cooling or heating.
- The fan on demand function cannot be activated with “Fan only” mode.





AUTO FAN
active

This option may be disabled, depending on system configuration.

1.8 Lock the thermostat's buttons

- Press and hold the  button to lock or unlock the thermostat's buttons. When locked, the  icon will appear on display.

1.9 Timer for turning the thermostat off

- Press and hold the  button – the hours for the off-timer will appear on display. Adjust the timer using the  and  buttons.

Range: 0...10 Hours

Note: Set “0” to disable the timer.

1.10 Economy mode indications E1 – E6

- Economy mode can be activated by triggering a window contact, door switch, key-tag or PIR sensor.
- When Economy mode is active, the thermostat will either turn off or use special economy set points for cooling and heating set by technician.

Please refer to parameters P25 and P26 in the technician setting section of this manual.

- The following indications will appear on display:
 - **E1** – Economy mode triggered by window contact
 - **E2** – Economy mode triggered by PIR (occupancy sensor)
 - **E4** – Economy mode triggered by door switch or key-tag
 - **E5** – OFF state triggered by door switch or key-tag
 - **E6** – Valves OFF and Fan low triggered by door switch or key-tag

1.11 Freeze protection

The Freeze protection feature will not allow the room temperature to drop below predefined cut-in temperature. Depending on which configuration the system is operating under (with or without Heat pump) this feature will force the system to operate in heat mode and activate the fan.

This feature will take effect when the thermostat is either ON or OFF. When the room temperature rises above the predefined cut-out temperature, the thermostat will return to its previous state.

When freeze protection is activated, the display alternates between “AL” and room temperature.

For selection of cut-in and cut-out temperatures, please refer to technician settings parameters P36 and P37.

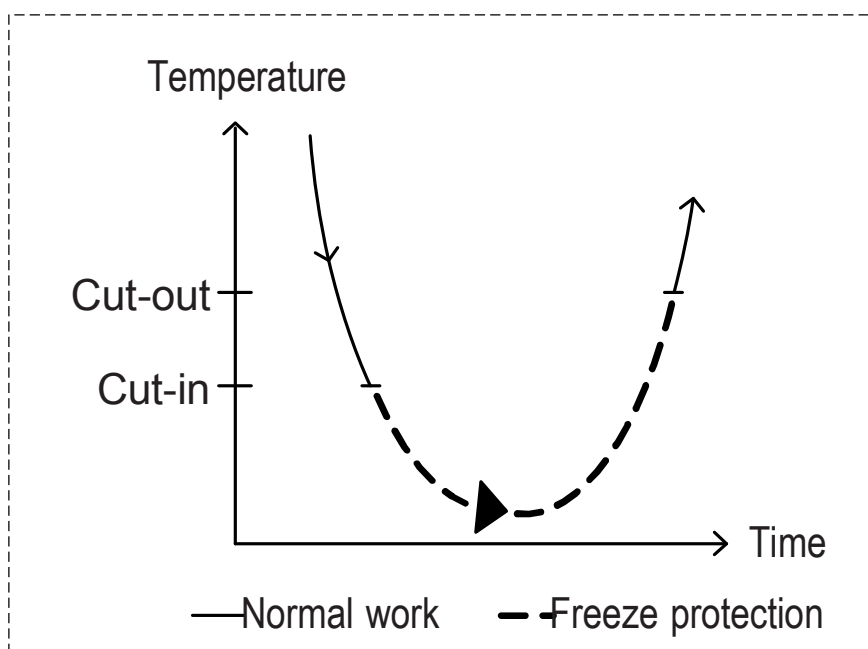

2. Installation Instructions

The MTS/SUPER Thermostat designed for flush mounting in the room to be controlled. It should be located where the occupant can easily read the display and use the controls.

If the built in temperature sensor is being used to measure room temperature, the panel should be placed where the temperature is representative of the general room conditions, away from cold or warm air draughts, radiant heat and direct sunlight.

The panel should not be installed on an outside wall.

- The standard installation height is 1.5 meter (5 feet) from the floor.



WARNING: Risk of Electric Shock and Property Damage.
Disconnect power supply before making electrical connections.
The installation is to be performed by a qualified electrician.



WARNING: The integrated circuits in the controller are sensitive to static currents. Take suitable precautions.

2. Installation Instructions (cont')

Installation procedure:

1. separate the front display from the back plastic cover by inserting a a small flat screwdriver into each of the three slots as shown in the picture and rotating it gently.
2. Remove the front display and keep it in a safe place.
3. Connect the wires as shown in the enclosed wiring diagram. All terminals accept 1x0.5mm²/24 AWG.
4. If necessary, make changes to the DIP switches position as explained in this manual.
5. Place the thermostat in the electrical box and tighten up the 2 screws
Europe - Gewiss Box - GW 24 203 or similar
US - Carlon – B114R or similar or similar
6. Adapt the front frame-panel into its place, by pushing it towards the wall.

2. Installation Instructions (cont')

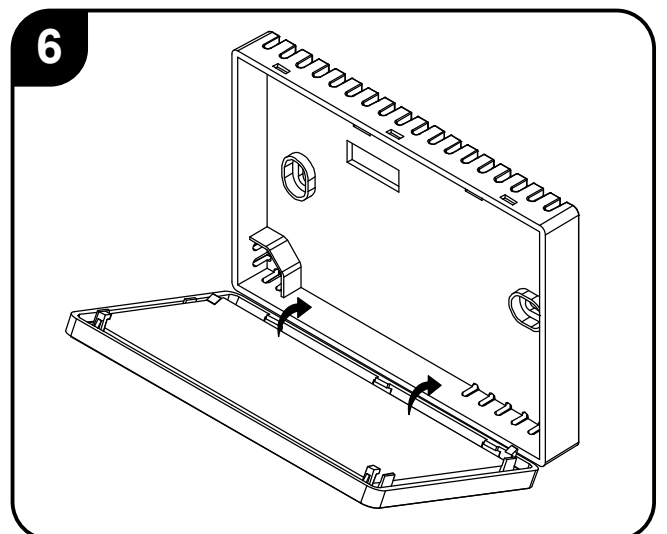
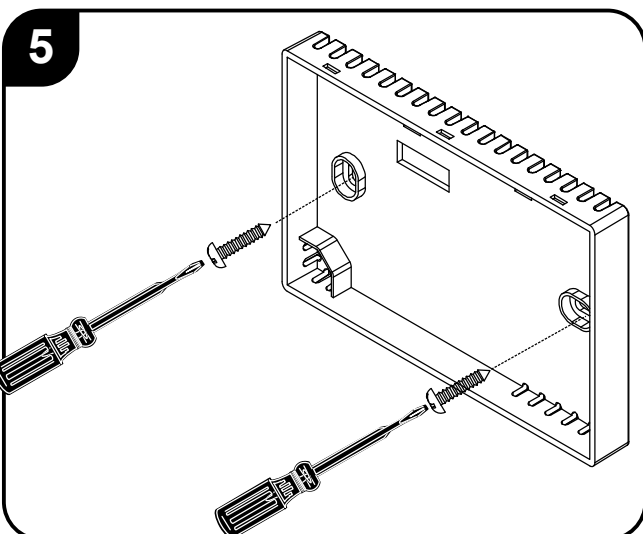
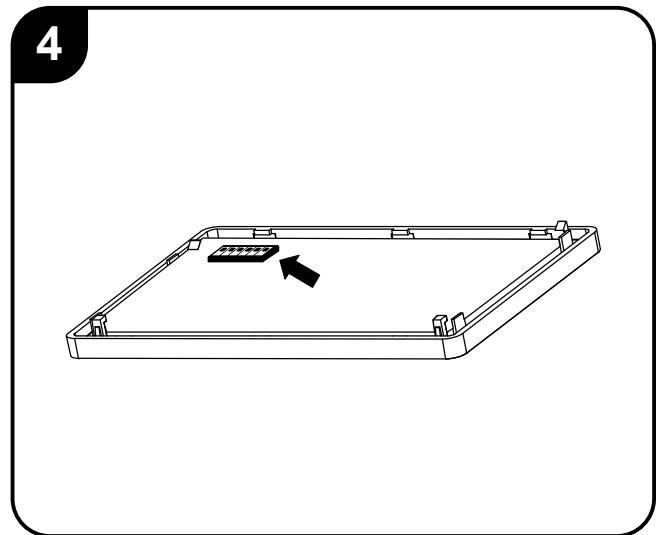
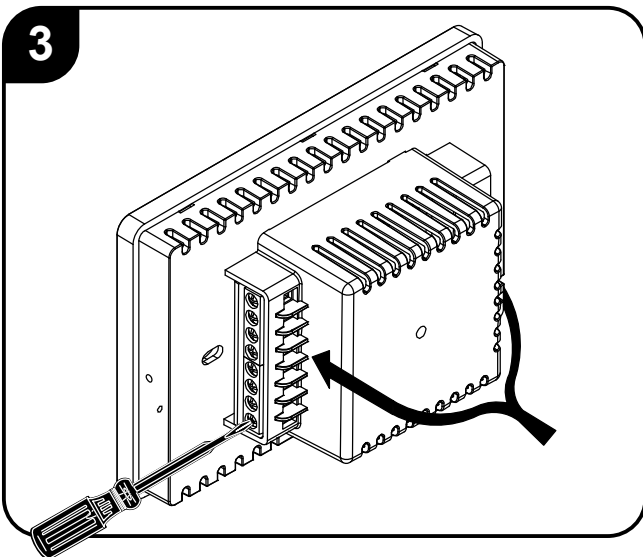
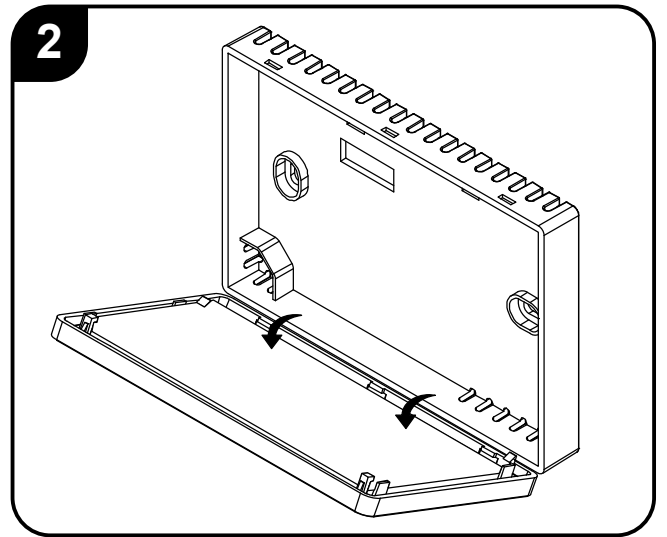
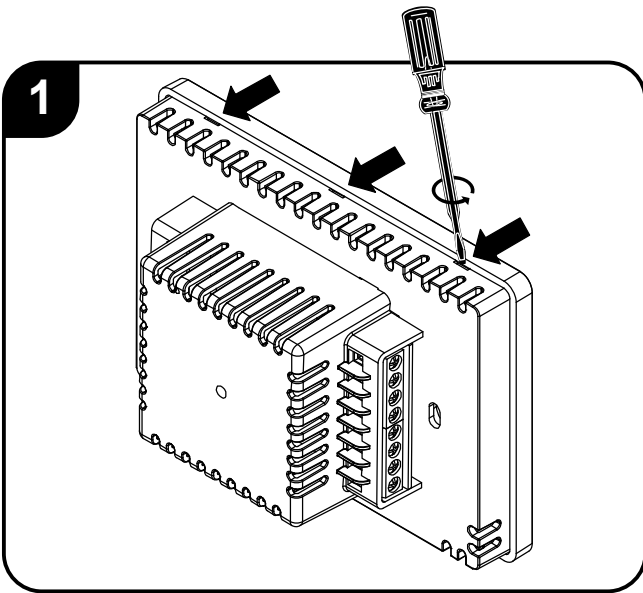

3. Wiring configuration and DIP Switches

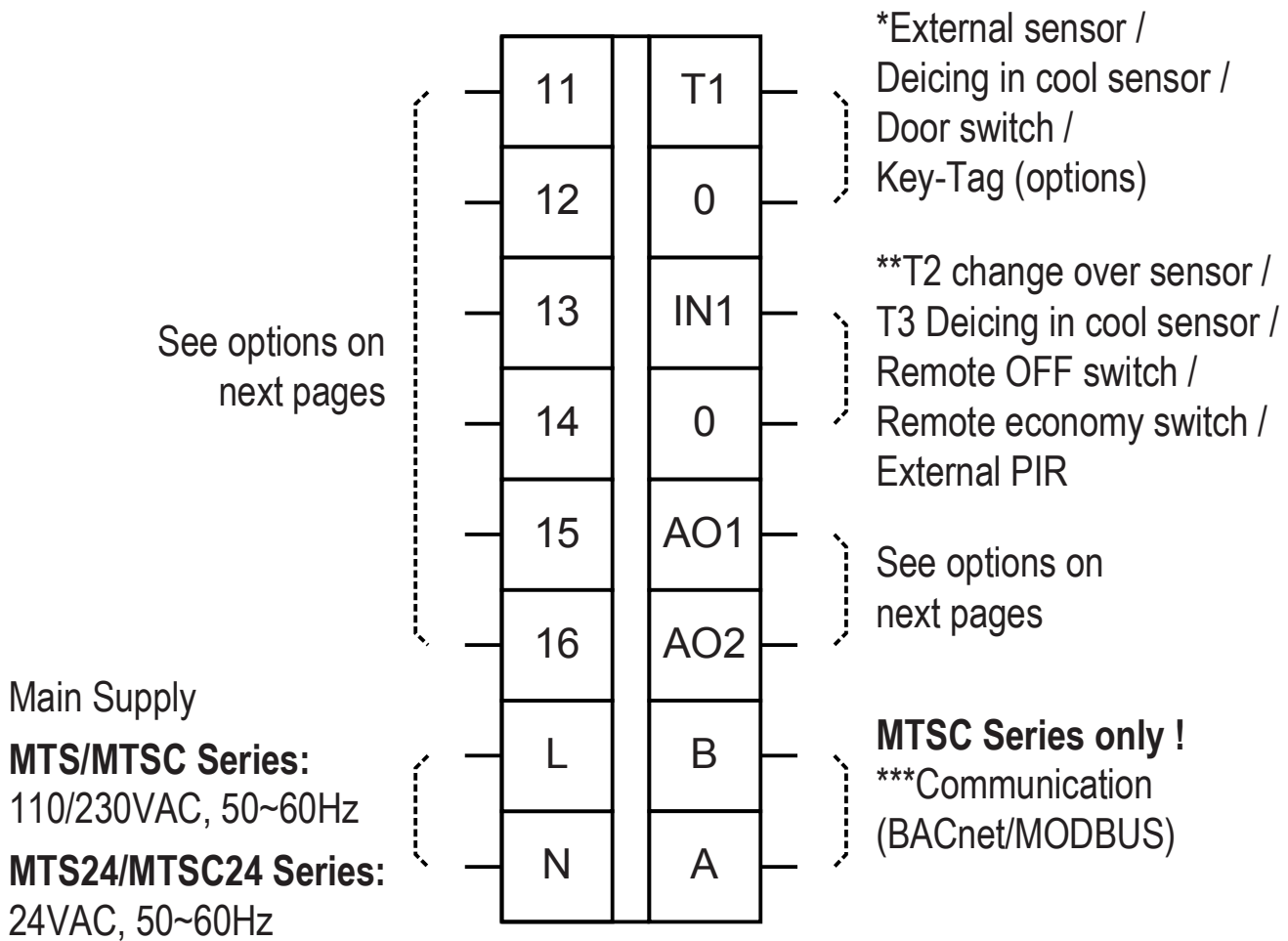

- * For T1,0 functionality – refer to parameter P8 in the technician settings section.
- ** For IN1,0 functionality – refer to parameter P9 in the technician settings section.
- ***Communication protocol (MTSC Series only) is set by DIP Switch S1.8 as follows:
 S1.8 ON – BACnet
 S1.8 OFF – MODBUS

Current ratings:

Outputs 11-16 24/110/230VAC - depending on supply voltage,
 3A maximum each 5A total

Outputs AO1, AO2 0-10VDC, 5mA

3. Wiring configuration and DIP Switches – AC systems

	HC32 1 Speed fan	HP42 1 Speed fan	HP22 3 Speed fan	HP21 3 Speed fan
11	Heat element 3	Heat element 2	Fan high	Fan high
12	Heat element 2	Heat element 1	Fan medium	Fan medium
13	Fan (1 speed)	Fan (1 speed)	Fan low	Fan low
14	Compressor 2	Compressor 2	Compressor 2	Heat element
15	Compressor 1	Compressor 1	Compressor 1	Compressor 1
16	Heat element 1 (see SW1.4 HC)	Heat pump (see SW1.4 HP)	Heat pump (see SW1.4 HP)	Heat pump (see SW1.4 HP)
AO1	X	X	X	X
AO2	X	X	X	X

Fan on/off: 24/110/230VAC, 3A max.

Control - Heat elements, Heat pump, Compressors: 24/110/230VAC, 0.3A max.

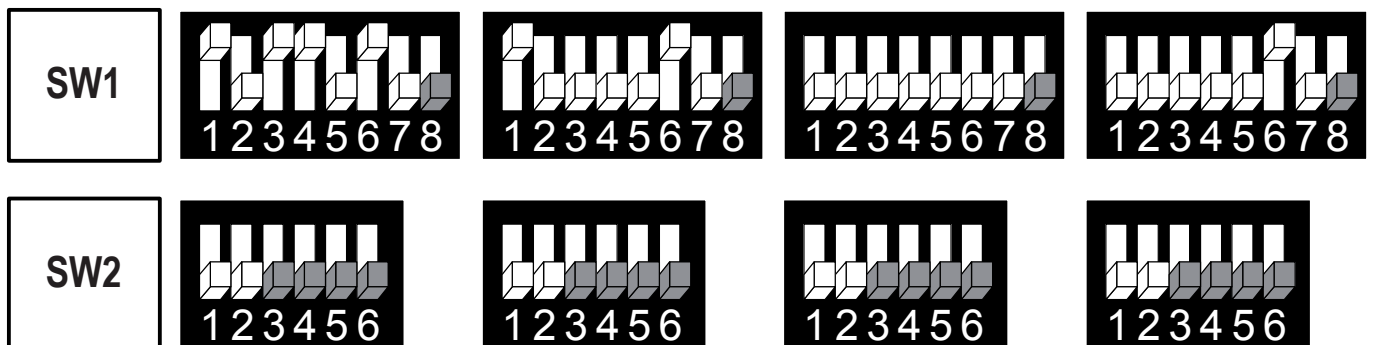

MTSC Series: SW1.8 = Communication Protocol: ON – BACnet, OFF – MODBUS

SW1.4 = HP: ON – Heat pump active in cool, OFF – Heat pump active in heat

HC: ON – Electrical heater, OFF – Oil/Gas heater (no fan)

SW1.5 = ON: Disable compressor delay, OFF – Enable compressor delay

S2.3 – S2.6 – Not in use

HP - Heat pump system HC - Non heat pump system ## - Heating/Cooling stages

3. Wiring configuration and DIP Switches – AC systems

	HC21 3 Speeds fan	HP22 Fan VFS	HP21 Fan VFS	HC21 Fan VFS
11	Fan high	Fan high	Fan high	Fan high
12	Fan medium	Fan medium	Fan medium	Fan medium
13	Fan low	Fan low	Fan low	Fan low
14	Heat element 2	Compressor 2	Heat element	Heat element 2
15	Compressor 1	Compressor 1	Compressor	Compressor 1
16	Heat element 1 (see SW1.4 HC)	Heat pump (see SW1.4 HP)	Heat pump (see SW1.4 HP)	Heat element 1 (see SW1.4 HC)
AO1	X	X	X	X
AO2	X	Fan VFS	Fan VFS	Fan VFS

Fan on/off: 24/110/230VAC, 3A max.

Fan VFS: 0-10VDC. 5mA Not isolated

Control - Heat elements, Heat pump, Compressors: 24/110/230VAC, 0.3A max.

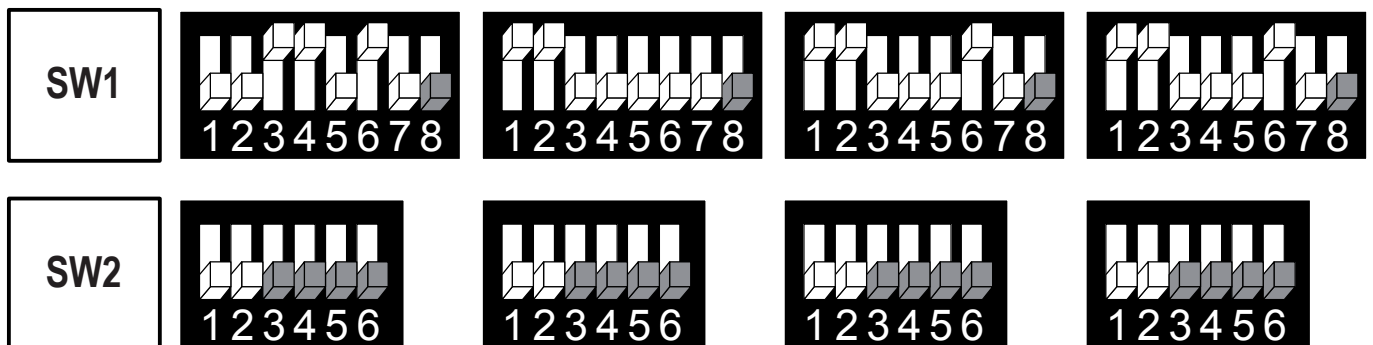

SW1.8 = Protocol: ON – BACnet, OFF – MODBUS

SW1.4 = HP: ON – Heat pump active in cool, OFF – Heat pump active in heat

HC: ON – Electrical heater, OFF – Oil/Gas heater (no fan)

SW1.5 = ON: Disable compressor delay, OFF – Enable compressor delay

S2.3 – S2.6 – Not in use

HP - Heat pump system HC - Non heat pump system ## - Heating/Cooling stages

3. Wiring configuration and DIP Switches – Fan coil systems

	2-Pipe 3 Speed	2-Pipe, 3 Speed Cool/Heat PID	2-Pipe Fan VFS	2-Pipe, Fan VFS Cool/Heat PID
11	Fan high	Fan high	Fan high	Fan high
12	Fan medium	Fan medium	Fan medium	Fan medium
13	Fan low	Fan low	Fan low	Fan low
14	Heat element (2 nd stage heat)	Heat element (2 nd stage heat)	Heat element (2 nd stage heat)	Heat element (2 nd stage heat)
15	Cool/Heat valve	X	Cool/Heat valve	X
16	X	X	X	X
AO1	X	Cool/Heat valve PID	X	Cool/Heat valve PID
AO2	X	X	Fan VFS	Fan VFS

Fan on/off: 24/110/230VAC, 3A max.

Fan VFS, PID valves: 0-10VDC. 5mA Not isolated

Control - Heat elements, Cool/Heat valves, Compressors: 24/110/230VAC, 0.3A max.

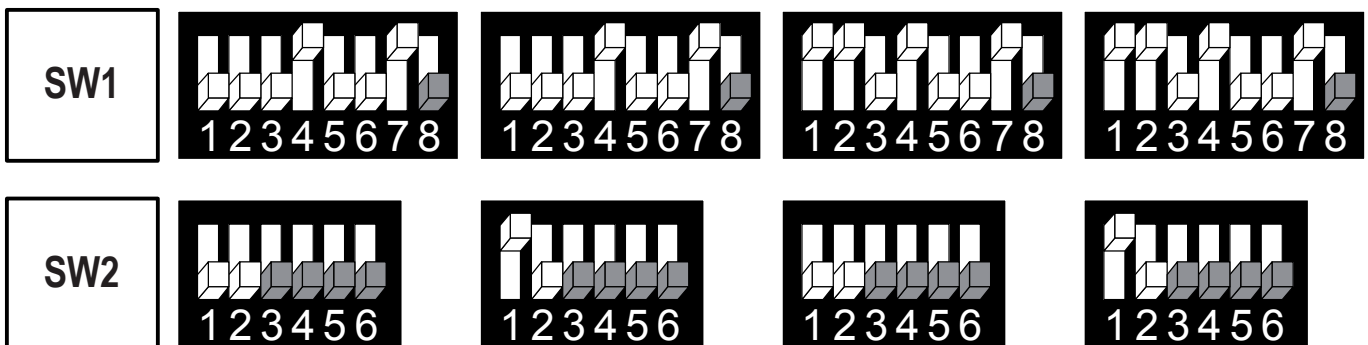

MTSC Series: SW1.8 = Communication Protocol: ON – BACnet, OFF – MODBUS

SW1.4 = Enable/Disable 2nd heating stage: ON – Enable, OFF – Disable

SW1.5 = Chilled beam option (fan will not run with 1st stage cooling) – SW1.5 ON

S2.3 – S2.6 – Not in use

3. Wiring configuration and DIP Switches – Fan coil systems

	4-Pipe 3 Speed fan	4-Pipe, 3 Speed Fan VFS	4-Pipe, 3 Speed Cool-PID	2-Pipe, 3 Speed Cool only**
11	Fan high	Fan high	Fan high	Fan high
12	Fan medium	Fan medium	Fan medium	Fan medium
13	Fan low	Fan low	Fan low	Fan low
14	Heat element (2 nd stage heat)	Heat element (2 nd stage heat)	Heat element (2 nd stage heat)	X
15	Cool valve	Cool valve	X	Cool valve
16	Heat valve (1 st stage heat)	Heat valve (1 st stage heat)	Heat valve (1 st stage heat)	X
AO1	X	X	Cool valve PID	X
AO2	X	Fan VFS	X	X

Fan on/off: 21/110/230VAC, 3A max.

Fan VFS, PID valves: 0-10VDC. 5mA Not isolated

Control - Heat elements, Cool/Heat valves, Compressors: 24/110/230VAC, 0.3A max.

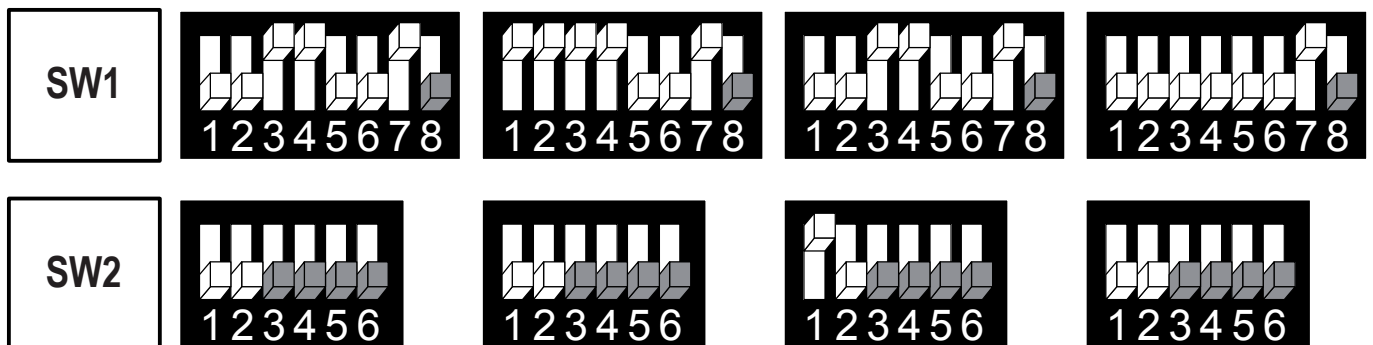

MTSC Series: SW1.8 = Communication Protocol: ON – BACnet, OFF – MODBUS

SW1.4 = Enable/Disable 2nd heating stage: ON – Enable, OFF – Disable

SW1.5 = Chilled beam option (fan will not run with 1st stage cooling) – SW1.5 ON

S2.3 – S2.6 – Not in use

**For Cool only configuration, change technician parameter P9 to “01” (change over sensor) and leave contact IN,0 open.

3. Wiring configuration and DIP Switches – Fan coil systems

	4-Pipe, Fan VFS Cool PID	4-Pipe, 3 Speed Heat PID	4-Pipe, Fan VFS Heat PID	4-Pipe, 3 Speed Heat PID, Cool PID
11	Fan high	Fan high	Fan high	Fan high
12	Fan medium	Fan medium	Fan medium	Fan medium
13	Fan low	Fan low	Fan low	Fan low
14	Heat element (2 nd stage heat)	Heat element (2 nd stage heat)	Heat element (2 nd stage heat)	Heat element (2 nd stage heat)
15	X	Cool valve	Cool valve	X
16	Heat valve (1 st stage heat)	X	X	X
AO1	Cool valve PID	Heat valve PID (1 st stage heat)	Heat valve PID (1 st stage heat)	Cool valve PID
AO2	Fan VFS	X	Fan VFS	Heat valve PID (1 st stage heat)

Fan on/off: 24/110/230VAC, 3A max.

Fan VFS, PID valves: 0-10VDC. 5mA Not isolated

Control - Heat elements, Cool/Heat valves, Compressors: 24/110/230VAC, 0.3A max.

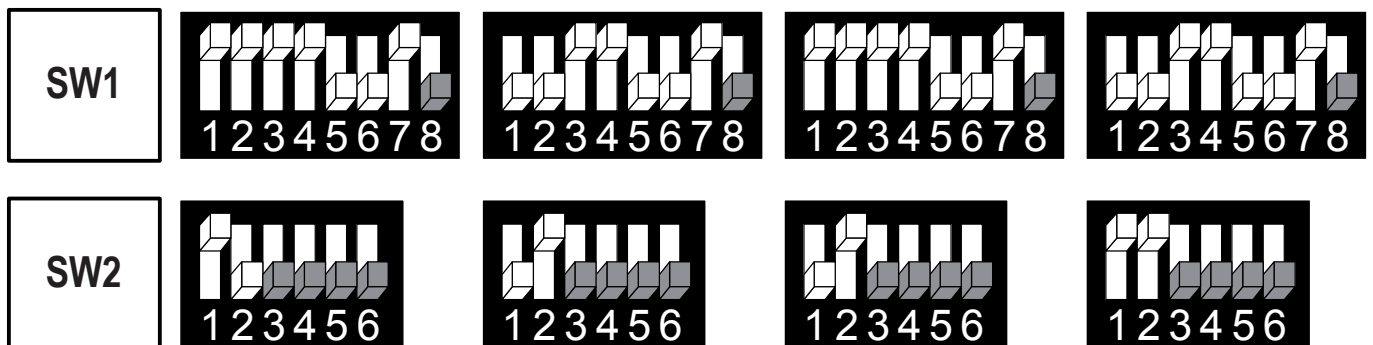

MTSC Series: SW1.8 = Communication Protocol: ON – BACnet, OFF – MODBUS

SW1.4 = Enable/Disable 2nd heating stage: ON – Enable, OFF – Disable

SW1.5 = Chilled beam option (fan will not run with 1st stage cooling) – SW1.5 ON

S2.3 – S2.6 – Not in use

3. Wiring configuration and DIP Switches – Fan coil systems

	4P-3S Floor heating	4-Pipe 3S C-PID Floor heating	4-Pipe VFS C-PID Floor heating
11	Fan high	Fan high	Fan high
12	Fan medium	Fan medium	Fan medium
13	Fan low	Fan low	Fan low
14	Floor heating (1 st stage heat)	Floor heating (1 st stage heat)	Floor heating (1 st stage heat)
15	Cool	X	X
16	Heat (2 nd stage heat)	Heat (2 nd stage heat)	Heat (2 nd stage heat)
AO1	X	Cool valve PID	Cool valve PID
AO2	X	X	Fan VFS

Fan on/off: 24/110/230VAC, 3A max.

Fan VFS, PID valves: 0-10VDC. 5mA Not isolated

Control - Heat elements, Cool/Heat valves, Compressors: 24/110/230VAC, 0.3A max.

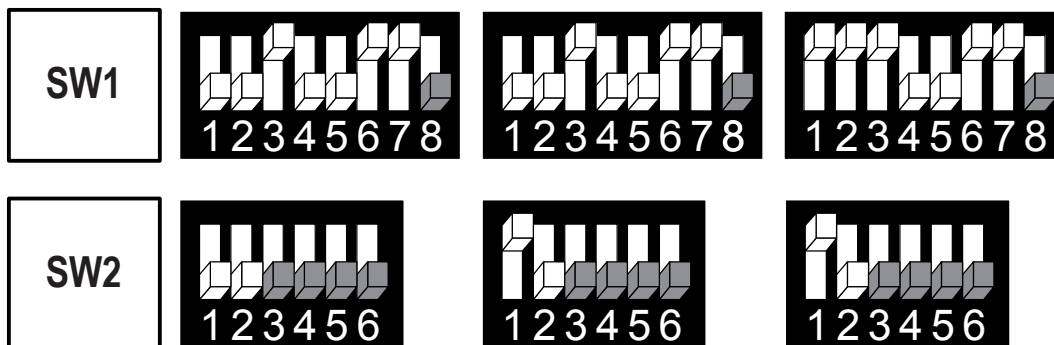

Floor heating – the fan will not run with 1st stage heat

MTSC Series: SW1.8 = Communication Protocol: ON – BACnet, OFF – MODBUS

SW1.4 = Enable/Disable 2nd heating stage: ON – Enable, OFF – Disable





SW1.5 = Chilled beam option (fan will not run with 1st stage cooling) – SW1.5 ON

S2.3 – S2.6 – Not in use

C-PID = Cool valve PID H-PID = Heat valve PID VFS = Fan VFS

4. Technician Settings

Enter technician settings

- Adjust the set-point temperature to 10°C.
- To enter technician settings, press and hold the  button for 5 seconds.
- Use the  button to advance to the next parameter.
- Use the  button to return to return to the previous parameter.
- Press the  button or wait 60 seconds to exit technician settings and return to normal display.

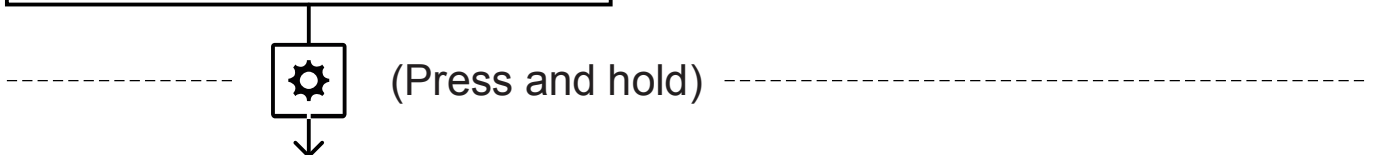
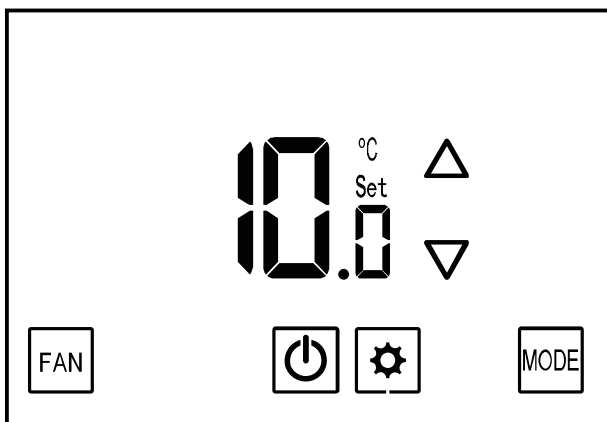

Note: The displayed parameters may depend on system configuration

4. Technician settings (cont')

P1 – Offset for temperature readings calibration

Range: -6...+6°C / -9...+9°F.

Default: 0°C / 0°F.

P2 – Set point limit for cooling

Range: 5...35°C / 41...90°F.

Default: 5°C / 35°F.

P3 – Set point limit for heating

Range: 5...35°C / 41...95°F.

Default: 35°C / 95°F.

P4 – Lock the [Fan] button

“01” - [Fan] button Locked

“00” - [Fan] button unlocked

P5 – Lock the [Mode] button

“01” - [Mode] button Locked

“00” - [Mode] button unlocked (default)

P6 – Lock the [On/Off] button

“01” - [On/Off] button Locked

“00” - [On/Off] button unlocked (default)

4. Technician settings (cont')

P7 – Lock the [+] and [-] buttons (Set buttons)

- "01" - [+] and [-] buttons Locked
 - "00" - [+] and [-] buttons unlocked (default)
-

P8 – Functionality of T1 terminals

- "00" - T1 terminals are not in use (default)
- "01" - External sensor
- "02" - T3 - Deicing in cool (AC)
- "03" - Door switch*
- "04" - Key-tag*

*Voltage free contacts - for polarity and time delay –
see technician parameters P12 and P13

P9 – Functionality of IN1,0 terminals

- "00" - IN1,0 terminals are not in use (default)
- "01" - T2 (Change over sensor) in FC / De-Ice in Heat in A/C
In Cool only configuration, select "01" and leave
contact open.
- "02" - T3 - Deicing in cool (AC)
- "03" - Voltage free contact - Remote On/Off**
- "04" - Voltage free contact - Remote Economy**
- "05" - External Passive Infrared detector (PIR)

**Voltage free contacts - for polarity and time delay –
see technician parameters P10 and P11

4. Technician settings (cont')

P10 – Polarity of remote switch contact on terminals IN,0

(P09 = “03” or “04”)

“00” - Normally close (default)

“01” - Normally open

P11 – Time delay of remote switch contact on terminals IN,0

(P09 = “03” or “04”)

Range: 0...999 seconds.

Default: 600 seconds.

P12 – Polarity of door switch/key-tag contact on terminals T1,0

(P08 = “03” or “04”)

“00” - Normally close (default)

“01” - Normally open

P13 – Door switch / Door key-tag delay time

Range: 0...999 seconds

Default: 180 seconds

P14 – Enable/Disable Auto change over mode

“00” - Disable Auto change over mode

“01” - Enable Auto change over mode (default)

P15 – Occupancy sensor logic (PIR)

“00” - Thermostat turns off when unoccupied
and back on when re-occupied

“01” - Thermostat turns off when unoccupied
and remains off when re-occupied

“02” - Thermostat uses economy set points (default)

4. Technician settings (cont')

P16 – Enable/Disable Occupancy sensor

- “00” - Disable
 - “01” - Enable (default)
-

P17 – PIR (occupancy sensor) delay time before switching to unoccupied mode (ON delay)

Range: 0...250 minutes, Default: 20 minutes

P18 – Door switch/key-tag logic

- “00” - Thermostat turns off when unoccupied and back on when re-occupied.
 - “01” - Thermostat uses economy set points when unoccupied.
 - “02” - Valves turn OFF and fan running on low speed when unoccupied.
-

P19 – PIR (Occupancy sensor) polarity

- “00” - Normally open (default)
 - “01” - Normally close
-

P25 – Economy set point for cooling

Range: 5...35°C / 41...90°F
Default: 30°C / 86°F

P26 – Economy set point for heating

Range: 5...35°C / 41...90°F
Default: 10°C / 50°F

4. Technician settings (cont')

P27 – Time on-delay between heating stages

Range: 0...600 seconds

Default: 5 seconds

P28 – Time off-delay between heating stages

Range: 0...600 seconds

Default: 1 seconds

P30 – Beeper ON or OFF

“01” - Beeper ON (default)

“00” - Beeper OFF

P31 – Fan ON delay in cooling (seconds) (FC only!)

Range: 0...120 seconds

Default: 0 seconds (no delay)

P32 – Fan OFF delay in cooling (seconds)

Range: 0...120 seconds

Default: 0 seconds (no delay)

P33 – Fan ON delay in heating (seconds) (FC only!)

Range: 0...120 seconds

Default: 0 seconds (no delay)

P34 – Fan OFF delay in heating (seconds)

Range: 0...120 seconds

Default: 30 seconds

4. Technician settings (cont')

P35 – Enable/Disable Freeze protection

“01” - Enable freeze protection (default)

“00” - Disable freeze protection

P36 – Freeze protection cut-in set point

Range: 8...15°C / 46...59°F

Default: 8°C / 46°F

P37 – Freeze protection cut-out set point

Range: 10...17°C / 50...63°F

Default: 10°C / 50°F

P40 – View filter counter (hours) – Read only

Range: 0...999 hours

P41 – Reset filter time

“00” - No action - keep counting (default)

“01” - Reset filter counter

P42 – Adjust filter alarm delay time counter (hours)

Range: 0...999 hours

Default: 0 hours (0 = Disable)

4. Technician settings (cont')

P43 – Not in use

P44 – Not in use

P45 – Cool differential band (On/Off)

Range: 0...5°C / 0...10°F

Default: 1°C / 2°F

P46 – Cool differential band offset

Range: 0...5°C / 0...10°F

Default: 0°C / 0°F

P47 – Heat differential band (On/Off)

Range: 0...5°C / 0...10°F

Default: 1°C / 2°F

P48 – Heat differential band offset

Range: -5...0°C / -10...0°F

Default: 0°C / 0°F

4. Technician settings (cont')

P49 – Shift between Cool and Heat in Auto change over mode

Range: 0...10°C / 0...20°F

Default: 2°C / 4°F

P50 – Shift between Cooling stages (AC only!)

Range: 0...10°C / 0...20°F

Default: 2°C / 4°F

P51 – Shift between Heating stages

Range: 0...10°C / 0...20°F

Default: 2°C / 4°F

P52 – Cool proportional band (FC only!)

Range: 2...10°C / 4...20°F

Default: 2°C / 4°F

P53 – Cool proportional low limit (FC only!)

Range: 0...100%

Default: 0%

P54 – Cool proportional high limit (FC only!)

Range: 0...100%

Default: 100%

4. Technician settings (cont')

P55 – Heat proportional band (FC only!)

Range: 2...10°C / 4...20°F

Default: 2°C / 4°F

P56 – Heat proportional low limit (FC only!)

Range: 0...100%

Default: 0%

P57 – Heat proportional high limit (FC only!)

Range: 0...100%

Default: 100%

P60 – Proportional ON percent (FC only!)

Range: 0...30%

Default: 30%

P61 – Proportional OFF percent (FC only!)

Range: 0...20%

Default: 10%

4. Technician settings (cont')

P63 – Time on-delay between cooling stages (AC only!)

Range: 0...600 seconds

Default: 5 seconds

P64 – Time off-delay between cooling stages (AC only!)

Range: 0...600 seconds

Default: 1 seconds

P65 – Fan VFS proportional band in cooling

Range: 2...10°C / 4...20°F

Default: 2°C / 4°F

P66 – Fan VFS proportional band in heating

Range: 2...10°C / 4...20°F

Default: 2°C / 4°F

P67 – Fan VFS Low speed percent in cooling

Range: 0...30%

Default: 20%

P68 – Fan VFS Medium speed percent in cooling

Range: 30...60%

Default: 50%

P69 – Fan VFS High speed percent in cooling

Range: 60...100%

Default: 90%

4. Technician settings (cont')

P70 – Fan VFS Low speed percent in heating

Range: 0...30%

Default: 30%

P71 – Fan VFS Medium speed percent in heating

Range: 30...60%

Default: 50%

P72 – Fan VFS High speed percent in heating

Range: 60...100%

Default: 80%

P74 – VFS Medium speed differential

Range: 10...50%

Default: 35

P75 – VFS High speed differential

Range: 10...50%

Default: 35

4. Technician settings (cont')

P76 – Fan VFS Low limit in cooling

Range: 0...100%

Default: 0%

P77 – Fan VFS High limit in cooling

Range: 0...100%

Default: 100%

P78 – Fan VFS Low limit in heating

Range: 0...100%

Default: 0%

P79 – Fan VFS High limit in heating

Range: 0...100%

Default: 100%

P83 – View T2 temperature sensor readings

Note: If T2 is not connected, -9.8°C / -9.8°F
will appear on display

P84 – View T3 temperature sensor readings

Note: If T3 is not connected, -9.8°C / -9.8°F
will appear on display

4. Technician settings (cont')

P85 – Deice in cool – cut-in temperature (AC only!)

Range: -20...99°C

Default: 0°C

P86 – Deice in cool – cut-out temperature (AC only!)

Range: -20...99°C

Default: 8°C

P87 – Deice in heat time (AC only!)

Range: 120...420 Seconds

Default: 300 Seconds

P88 – Deice in heat break time (AC only!)

Range: 600...1800 Seconds

Default: 1500 Seconds

P89 – Deice in heat – cut-in temperature (AC only!)

Range: -20...99°C

Default: 0°C

P90 – Deice in heat – cut-out temperature (AC only!)

Range: -20...99°C

Default: 16°C

P91 – Compressor delay (AC only!)

Range: 0...360 Seconds

Default: 10 Seconds

4. Technician settings (cont')

P99 – One or Two set points (for cool and for heat) (FC only!)

“00” - One set point for cooling and heating (default)

“01” - two set points – one for cool and one for heat

P100 – Enable/Disable Screen dimming

“00” - Enable

“01” - Disable (default)

P101 – Screen dimming delay

Range: 0...99 minutes

Default: 5 minutes

P102 – Dimming percentage value

Range: 1,5,10...90%

Default: 10%

P105 – Display brightness

Range: 50...100%

Default: 100%

P114 – Cool PID Kp (FC only!)

Range: 0...100%

Default: 100%

P115 – Heat PID Kp (FC only!)

Range: 0...100%

Default: 100%

4. Technician settings (cont')

P116 – Cool PID Ki (FC only!)

Range: 0...100%

Default: 0%

P117 – Heat PID Ki (FC only!)

Range: 0...100%

Default: 0%

P118 – Cool PID Kd (FC only!)

Range: 0...100%

Default: 1%

P119 – Heat PID Kd (FC only!)

Range: 0...100%

Default: 1%

P198 – Protocol indication (read only!)

0 - MODBUS

1 - BACnet

P200 – Restore defaults





Press the  button to restore defaults

Press the  button twice to return to normal display

Press the  button to return to parameter P1 or wait 60 seconds to exit technician settings and return to normal display.

5. MAC Address (MTSC Series only)

Enter MAC Address settings

- Adjust the set-point temperature to 11°C – the button  will appear on display.
- To enter MAC Address settings, press and hold the  button for 5 seconds.
- Use the  and  buttons to change the MAC Address.
Set “0” for no communication.
- Press the  button to return to normal display.

Comments

Comments

Comments

A series of 18 horizontal dashed lines provided for writing comments.

