

AIR CONDITIONER

Cassette type

SERVICE MANUAL

INDOOR



AUXG36KRLB
AUXG45KRLB
AUXG54KRLB

OUTDOOR



AOYG36KRTA



AOYG45KRTA
AOYG54KRTA

Notices:

- Product specifications and design are subject to change without notice for future improvement.
- For further details, please check with our authorized dealer.

Trademarks

FGLair™ is trademark of Fujitsu General Limited in the United States, other countries or both.

Google Play™ is trademark of Google Inc.

App Store® is a service mark of Apple Inc., registered in the U.S. and other countries.

CONTENTS

1. GENERAL INFORMATION

2. TECHNICAL DATA AND PARTS LIST

3. TROUBLESHOOTING

4. CONTROL AND FUNCTIONS

5. FIELD WORKING

1. GENERAL INFORMATION

CONTENTS

1. GENERAL INFORMATION

1. Specifications	01-1
1-1. Indoor unit	01-1
1-2. Outdoor unit.....	01-3
2. Dimensions	01-5
2-1. Indoor unit	01-5
2-2. Outdoor unit.....	01-8

1. Specifications

1-1. Indoor unit

Type				Cassette		
				Inverter heat pump		
Model name				AUXG36KRLB	AUXG45KRLB	AUXG54KRLB
Power supply				3N 400 V ~ 50 Hz		
Power supply intake				Outdoor unit		
Available voltage range				342—457 V		
Capacity	Cooling	Rated	kW	9.5	12.1	13.4
			Btu/h	32,400	41,300	45,700
		Min.—Max.	kW	2.8—11.2	4.0—14.0	4.5—14.5
	Heating	Rated	Btu/h	9,600—38,200	13,600—47,800	15,400—49,500
			kW	10.8	13.5	15.5
		Min.—Max.	Btu/h	36,850	46,000	52,900
Input power	Cooling	Rated	kW	2.91	3.61	4.41
			Max.	4.19	5.00	5.23
		Heating	Rated	2.45	3.21	4.16
	Heating	Rated	Max.	4.48	4.69	4.77
			kW	2.7—12.7	4.2—16.2	4.7—16.5
		Btu/h	9,200—43,300	14,300—55,300	16,000—56,300	
Current	Cooling	Rated	A	5.6	6.8	8.0
	Heating		4.8	6.1	7.6	
Power factor	Cooling		%	75.2	77.4	80.3
	Heating		73.8	76.1	79.4	
EER	Cooling		kW/kW	3.26	3.35	3.04
COP	Heating		4.40	4.20	3.73	
Moisture removal			L/h (pints/h)	3.3 (5.8)	4.5 (7.9)	5.0 (8.8)
Maximum operating current *1	Cooling		A	10.5	14.0	
	Heating		10.5	14.0		
Fan	Airflow rate	Cooling	HIGH	1,870	2,000	2,100
			MED	1,560	1,650	1,780
			LOW	1,410	1,460	1,600
			QUIET	1,160	1,300	1,320
		Heating	HIGH	1,870	2,000	2,100
			MED	1,560	1,650	1,780
			LOW	1,410	1,460	1,600
			QUIET	1,160	1,300	1,320
	Type × Q'ty			Turbo fan × 1		
	Motor output			W	81	
Sound pressure level *2	Cooling		HIGH	44	46	47
			MED	41	42	43
			LOW	38	39	40
			QUIET	34	35	36
	Heating		HIGH	44	46	47
			MED	41	42	43
			LOW	38	39	40
			QUIET	34	35	36
Heat exchanger type	Dimensions (H × W × D)		mm	Main1: 252 × 2,131 × 13.3, Main2: 252 × 2,064 × 13.3, Main3: 252 × 1,999 × 13.3		
	Fin pitch			Main 1: 1.3, Main 2: 1.3, Main 3: 1.3		
	Rows × Stages			Main 1: 1 × 12, Main 2: 1 × 12, Main 3: 1 × 12		
	Pipe type			Copper tube		
	Fin type			Aluminum		
Dimensions (H × W × D)	Net		mm	288 × 840 × 840		
	Gross			340 × 960 × 950		
Weight	Net		kg	29		
	Gross			34		
Connection pipe	Size	Liquid	mm (in)	Ø 9.52 (3/8)		
		Gas		Ø 15.88 (5/8)		
Drain hose	Method			Flare		
	Material			PVC		
Operation range	Size		mm	Ø 25 (I.D.), Ø 32 (O.D.)		
	Cooling	°C		18 to 32		
		%RH		80 or less		
Heating	°C		16 to 30			
Cassette grille (Option)	Model name			UTG-UKYC-W		
	Material			Polystyrene		
	Color			White		
				Approximate color of MUNSELL N 9.25/		
	Dimensions (H × W × D)	Net	mm	53 × 950 × 950		
		Gross		110 × 1,000 × 1,010		
Weight	Net	kg	6.0			
	Gross		10.0			
Remote control (Option)				Wired remote controller, Wireless remote controller, Mobile app*3 (FGLair™)		

NOTES:

- Specifications are based on the following conditions:
 - Cooling: Indoor temperature of 27 °CDB/19 °CWB, and outdoor temperature of 35 °CDB/24 °CWB.
 - Heating: Indoor temperature of 20 °CDB/15 °CWB, and outdoor temperature of 7 °CDB/6 °CWB.
 - Pipe length: 5.0 m, Height difference: 0 m. (Between outdoor unit and indoor unit.)
- Protective function might work when using it outside the operation range.
- *1: Maximum operating current is the total current of the indoor unit and the outdoor unit.
- *2: Sound pressure level:
 - Measured values in manufacturer's anechoic chamber.
 - Because of the surrounding sound environment, the sound levels measured in actual installation conditions might be higher than the specified values here.
- *3: Available on Google Play™ store or on App Store®. Optional WLAN adapter is also required. For details, refer to the setting manual.
- This data is based on EN 14511 standard.

Specifications for ErP Lot10			
Model name		AUXG36KRLB	
Energy efficiency class	Cooling		A ⁺⁺
	Heating (Average)		A ⁺
Pdesign	Cooling	kW	9.5 (35°C)
	Heating (Average)		8.7 (-10°C)
SEER	Cooling	kWh/kWh	6.55
SCOP	Heating (Average)		4.3
Annual energy consumption	QCE	kWh/a	507
	QHE (Average)		2,828
Sound power level	Cooling	HIGH	dB (A)
	Heating		

1-2. Outdoor unit

Type				Inverter heat pump	
Model name				AOYG36KRTA	
Power supply				3N 400 V ~ 50 Hz	
Power supply intake				Outdoor unit	
Available voltage range				342–457 V	
Starting current				5.6	
Fan	Airflow rate	Cooling	m ³ /h	3,750	
		Heating		3,750	
	Type × Q'ty			Propeller × 1	
	Motor output		W	100	
Sound pressure level *1		Cooling	dB (A)	55	
		Heating		55	
Sound power level		Cooling	dB (A)	70	
		Heating		70	
Heat exchanger type		Dimensions (H × W × D)	mm	Main1: 756 × 905 × 18.20 Main2: 756 × 905 × 18.20	
		Fin pitch		Main1: 1.45 Main2: 1.45	
		Rows × Stages		Main1: 1 × 36 Main2: 1 × 36	
		Pipe type		Copper	
		Fin	Type (Material)	Aluminum	
			Surface treatment	Blue fin	
Compressor	Type			DC twin rotary	
	Motor output		W	1,500	
Refrigerant		Type (Global warming potential)	R32 (675)		
		Factory charge	g	1,900	
Refrigerant oil		Type	FW68D		
		Amount	cm ³	600	
Enclosure		Material	Steel sheet		
		Color	Beige Approximate color of Munsell 10YR 7.5/1.0		
Dimensions (H × W × D)		Net	mm	788 × 940 × 320	
		Gross		966 × 1,027 × 445	
Weight		Net	kg	53	
		Gross		62	
Connection pipe		Size	Liquid	Ø 9.52 (3/8)	
			Gas	Ø 15.88 (5/8)	
		Method		Flare	
		Pre-charge length		m	30
		Max. length			50
		Max. height difference			30
Operation range		Cooling	°C	-15 to 46	
		Heating		-15 to 24	
Drain hose		Material	LDPE		
		Tip diameter	mm	Ø 13.0 (I. D.), Ø 16.0 to Ø 16.7 (O. D.)	

NOTES:

- Specifications are based on the following conditions:
 - Cooling: Indoor temperature of 27 °CDB/19 °CWB, and outdoor temperature of 35 °CDB/24 °CWB.
 - Heating: Indoor temperature of 20 °CDB/15 °CWB, and outdoor temperature of 7 °CDB/6 °CWB.
 - Pipe length: 5.0 m, Height difference: 0 m. (Between outdoor unit and indoor unit.)
- Protective function might work when using it outside the operation range.
- *1: Sound pressure level
 - Measured values in manufacturer's anechoic chamber.
 - Because of the surrounding sound environment, the sound levels measured in actual installation conditions might be higher than the specified values here.
- This data is based on EN 14511 standard.

Type				Inverter heat pump				
Model name				AOYG45KRTA		AOYG54KRTA		
Power supply				3N 400 V ~ 50 Hz				
Power supply intake				Outdoor unit				
Available voltage range				342—457 V				
Starting current				6.8		8.0		
Fan	Airflow rate	Cooling	m ³ /h	4,450				
		Heating		4,450				
	Type × Q'ty				Propeller × 1			
Motor output			W	120				
Sound pressure level *1		Cooling	dB (A)	57				
		Heating		59				
Sound power level		Cooling	dB (A)	57		73		
		Heating		71		73		
Heat exchanger type		Dimensions (H × W × D)		Main1: 966 × 905 × 18.20 Main2: 966 × 905 × 18.20 Sub: 966 × 543 × 18.20				
		Fin pitch		Main1: 1.45 Main2: 1.45 Sub: 1.45				
		Rows × Stages		Main1: 1 × 46 Main2: 1 × 46 Sub: 1 × 46				
		Pipe type		Copper				
		Fin		Type (Material)	Aluminum			
		Surface treatment		Blue fin				
Compressor		Type × Q'ty	DC Twin rotary × 1					
		Motor output		W				
Refrigerant		Type (Global warming potential)		R32 (675)				
		Factory charge		g				
Refrigerant oil		Type		RmM68AF				
		Amount		cm ³				
Enclosure		Material		Steel sheet				
		Color		Beige Approximate color of Munsell 10YR 7.5/1.0				
Dimensions (H × W × D)		Net		mm				
		Gross		998 × 940 × 320 1,176 × 1,027 × 445				
Weight		Net		kg				
		Gross		67 77				
Connection pipe		Size		Liquid	mm (in)			
				Gas	Ø 9.52 (3/8) Ø 15.88 (5/8)			
		Method		Flare				
		Pre-charge length		30				
		Max. length		50				
Max. height difference		30						
Operation range		Cooling	°C	-15 to 46				
		Heating		-15 to 24				
Drain hose		Material		LDPE				
		Tip diameter		mm				
		Ø 13.0 (I. D.), Ø 16.0 to Ø 16.7 (O. D.)						

NOTES:

- Specifications are based on the following conditions:
 - Cooling: Indoor temperature of 27 °CDB/19 °CWB, and outdoor temperature of 35 °CDB/24 °CWB.
 - Heating: Indoor temperature of 20 °CDB/15 °CWB, and outdoor temperature of 7 °CDB/6 °CWB.
 - Pipe length: 5.0 m, Height difference: 0 m. (Between outdoor unit and indoor unit.)
- Protective function might work when using it outside the operation range.
- *1: Sound pressure level
 - Measured values in manufacturer's anechoic chamber.
 - Because of the surrounding sound environment, the sound levels measured in actual installation conditions might be higher than the specified values here.
- This data is based on EN 14511 standard.

2. Dimensions

2-1. Indoor unit

■ Models: AUXG36KRLB, AUXG45KRLB, and AUXG54KRLB

Unit: mm

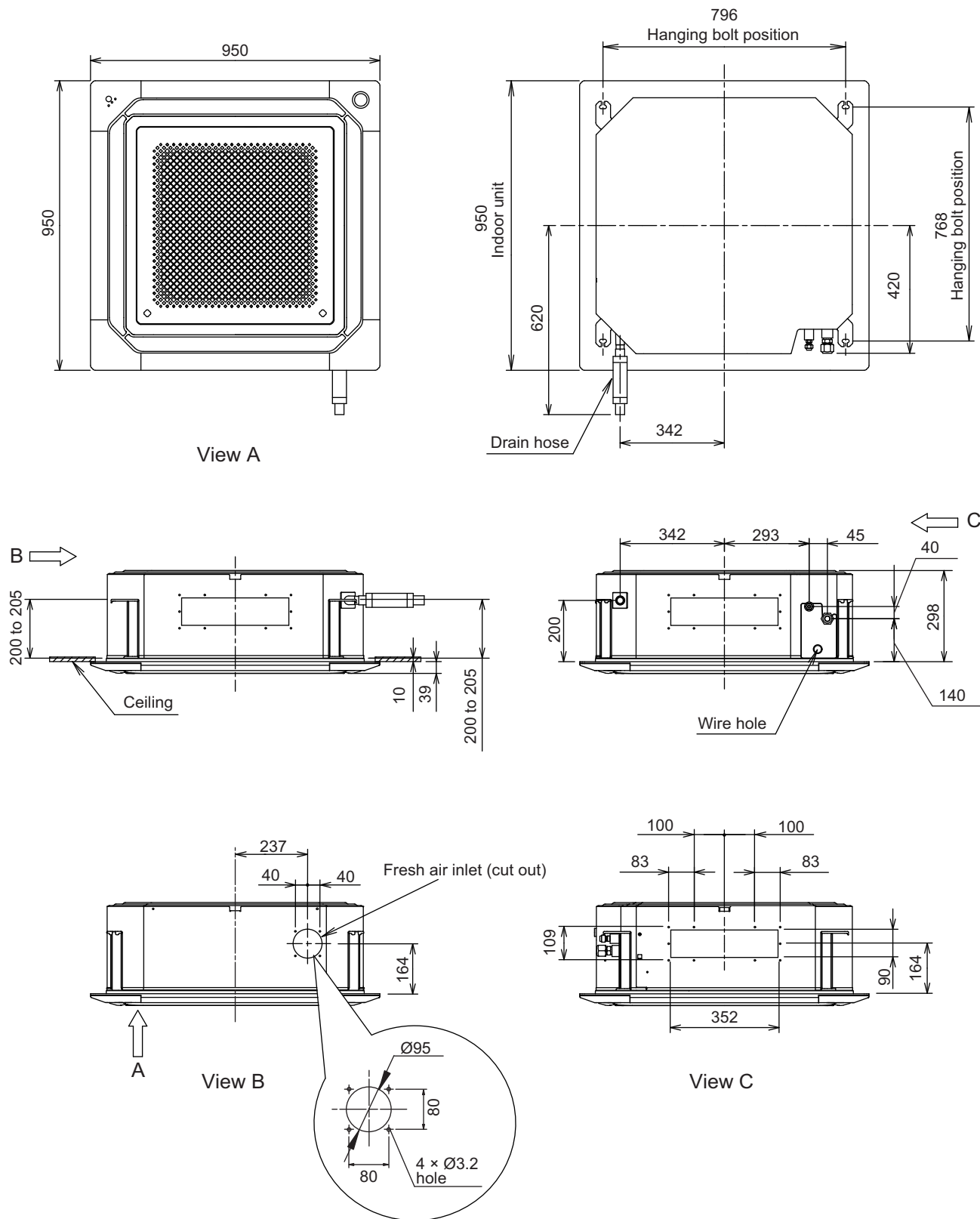

■ Installation space requirement

Unit: mm

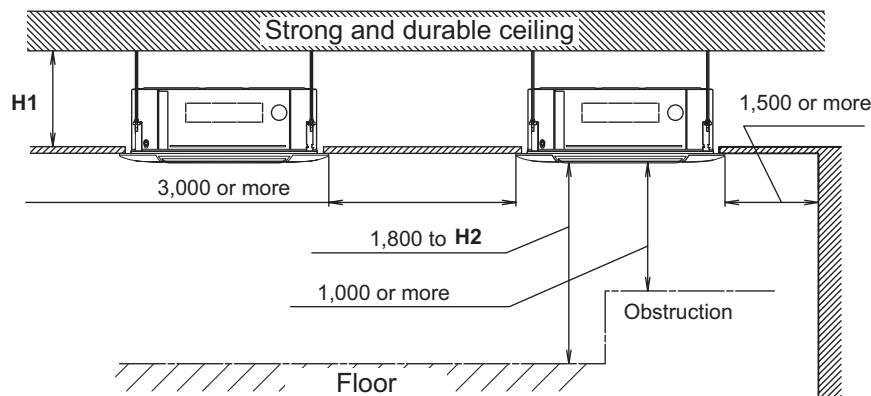

Model name	H1: Attic height
AUXG36-54KRLB	298 or more

Be sure to make function setting with the remote controller according to the installed ceiling height.

H2: The maximum height from floor to ceiling	
Ceiling height	Model name
	AUXG36-54KRLB
Standard	3,200
High ceiling	4,200

● Installation notices

- When installing the indoor unit, be careful about the maintenance space.
- To set "3-direction", Air outlet shutter plate (option) must be installed, and the "outlet-direction" need to be switched to "3-way" by the remote controller.

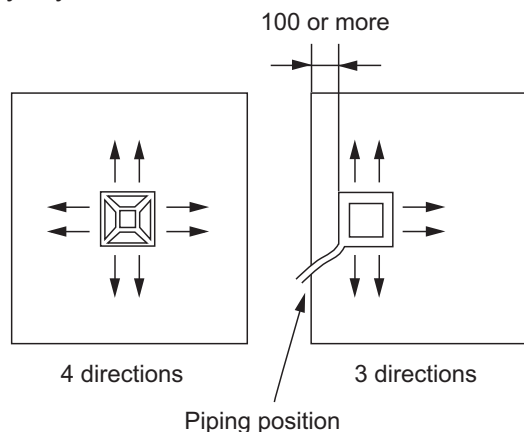

- In 3-way outlet mode, changing of ceiling height setting by function setting 20 is prohibited. (Ceiling height setting [function setting 20] is allowed to be changed only in 4-way outlet mode.)
- Use the Insulation kit for high humidity (option), when the condition under the roof is over 80% in humidity and over 30°C in temperature. Otherwise, there is a risk of condensation on the ceiling.

- Human sensor (Option)

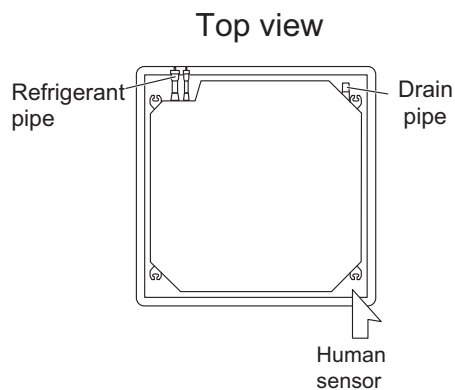

Example of sensitivity range:

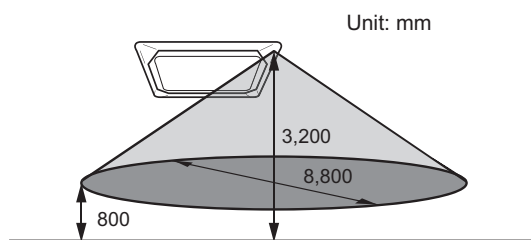

Equal sensitivity range of temperature	Ceiling height	3,200 mm
	Detecting position	800 mm from floor surface

NOTE: When the installation height gets higher, the temperature sensitivity decreases.

⚠ CAUTION

- Do not place large objects near the human sensor.
- Keep any other heating units outside the sensor's detection area.

2-2. Outdoor unit

■ Models: AOYG36KRTA

Unit: mm

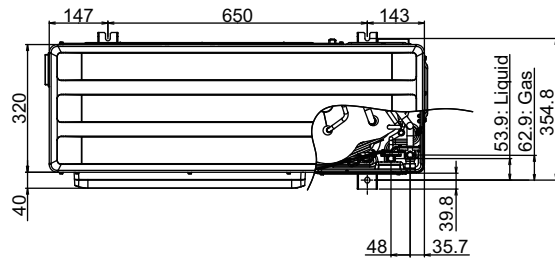

Top view

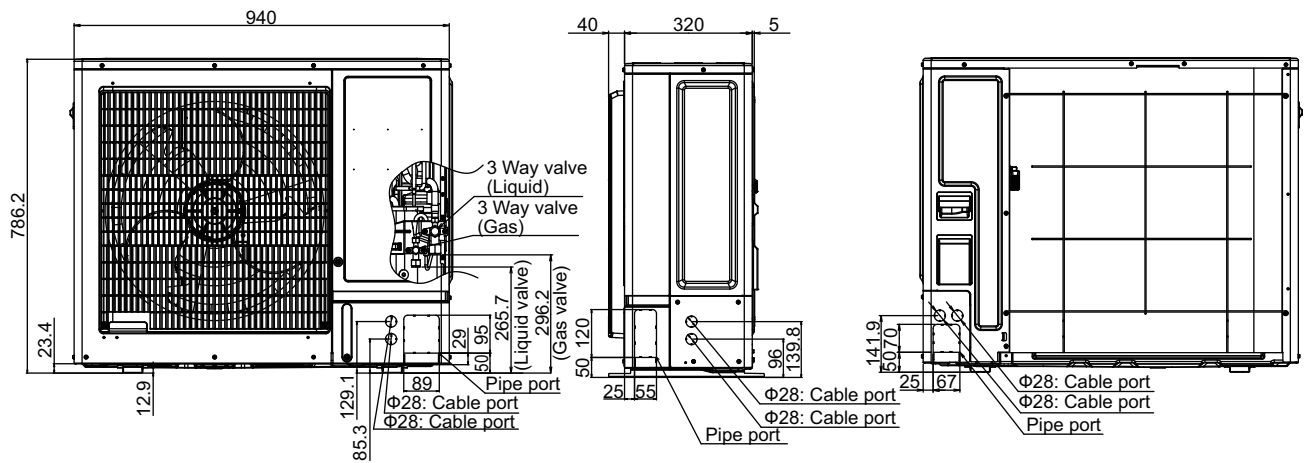

Front view

Side view

Rear view

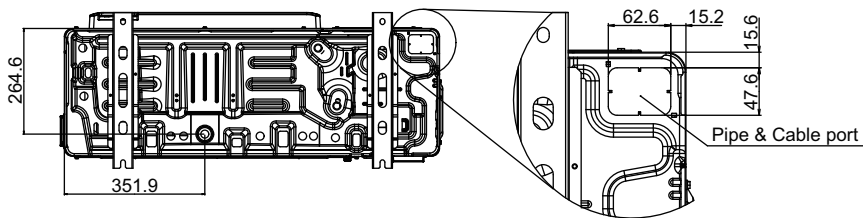

Bottom view

Models: AOYG45KRTA and AOYG54KRTA

Unit: mm

GENERAL INFORMATION

GENERAL INFORMATION

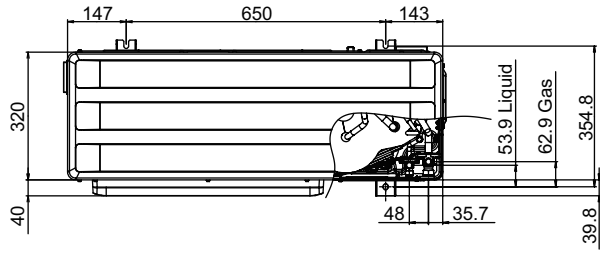

Top view

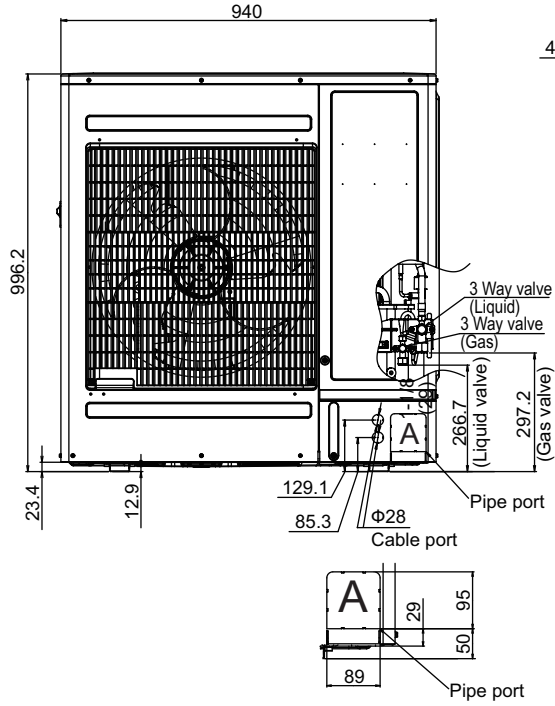

Front view

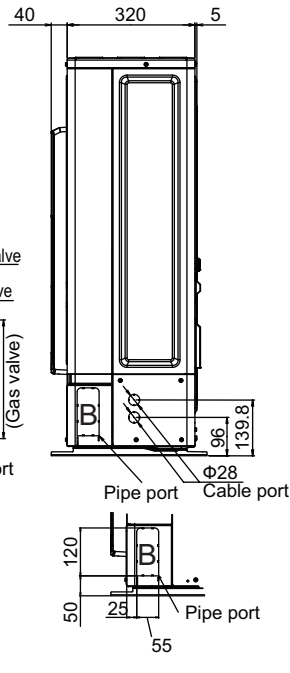

Side view

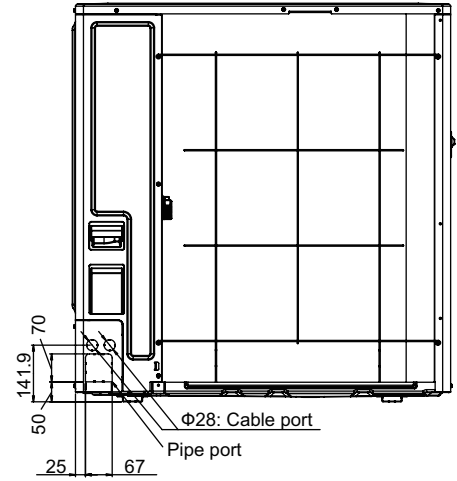

Rear view

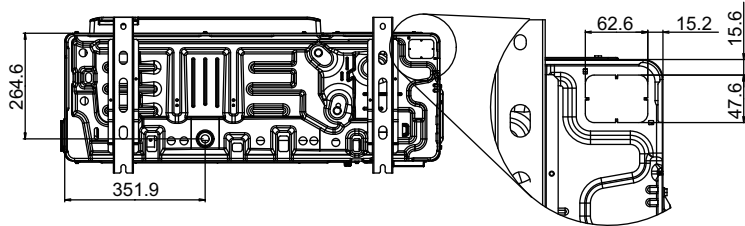

Bottom view

Pipe & Cable port

2. TECHNICAL DATA AND PARTS LIST

CONTENTS

2. TECHNICAL DATA AND PARTS LIST

1. Precautions	02-1
2. Cassette grille (optional part) parts list	02-2
2-1. Model: UTG-UKYC-W	02-2
3. Indoor unit parts list	02-5
3-1. Models: AUXG36KRLB, AUXG45KRLB, and AUXG54KRLB.....	02-5
4. Outdoor unit parts list	02-10
4-1. Model: AOYG36KRTA.....	02-10
4-2. Models: AOYG45KRTA and AOYG54KRTA	02-14
5. Accessories	02-18
5-1. Indoor unit	02-18
5-2. Outdoor unit.....	02-18
6. Optional parts	02-19
6-1. Indoor unit	02-19
6-2. Outdoor unit.....	02-22
7. Refrigerant system diagrams	02-23
7-1. Models: AOYG36KRTA, AOYG45KRTA, and AOYG54KRTA	02-23
8. Wiring diagram	02-24
8-1. Indoor unit	02-24
8-2. Outdoor unit.....	02-25
9. PC board diagrams	02-26
9-1. Models: AUXG36KRLB, AUXG45KRLB, and AUXG54KRLB.....	02-26
9-2. Models: AOYG36KRTA, AOYG45KRTA, and AOYG54KRTA	02-27

1. Precautions

When you start servicing, pay attention to the following points. For detailed precautions, refer to the installation manual of the products.

⚠ CAUTION

-
- Service personnel
 - Any person who is involved with working on or breaking into a refrigerant circuit should hold a current valid certificate from an industry-accredited assessment authority, which authorizes their competence to handle refrigerants safely in accordance with an industry recognized assessment specification.
 - Servicing shall only be performed as recommended by the equipment manufacturer. Maintenance and repair requiring the assistance of other skilled personnel shall be carried out under the supervision of the person competent in the use of flammable refrigerants.
 - Servicing shall be performed only as recommended by the manufacturer.
 - Work
 - Prior to beginning work on systems containing flammable refrigerants, safety checks are necessary to ensure that the risk of ignition is minimized. When repairing the refrigerant system, refer to the precautions written in the installation manual of the products before you start servicing.
 - Work shall be undertaken under a controlled procedure so as to minimize the risk of a flammable gas or vapor being present while the work is being performed.
 - All maintenance staff and others working in the local area shall be instructed on the nature of work being carried out.
 - Work in confined spaces shall be avoided.
 - The area around the workspace shall be sectioned off.
 - Ensure that the conditions within the area have been made safe by control of flammable material.
 - Electric shock may occur. After turning off the power, always wait 5 minutes before touching electrical components.
 - Do not touch the fins of the heat exchanger. Touching the heat exchanger fins could result in damage to the fins or personal injury such as skin rupture.
 - Do not place any other electrical products or household belongings under the product.
 - Condensation dripping from the product might get them wet, and may cause damage or malfunction to the property.
 - Checking for presence of refrigerant
 - The area shall be checked with an appropriate refrigerant detector prior to and during work, to ensure the technician is aware of potentially flammable atmospheres.
 - Ensure that the leak detection equipment being used is suitable for use with flammable refrigerants, i.e. non-sparking, adequately sealed or intrinsically safe.
-
- Service parts information and design are subject to change without notice for product improvement.
 - For the latest information of the service parts, refer to our Service Portal.
<https://fujitsu-general.force.com/portal/>
 - Precise figure of the service parts listed in this manual may differ from the actual service parts.

2. Cassette grille (optional part) parts list

2-1. Model: UTG-UKYC-W

■ Intake grille

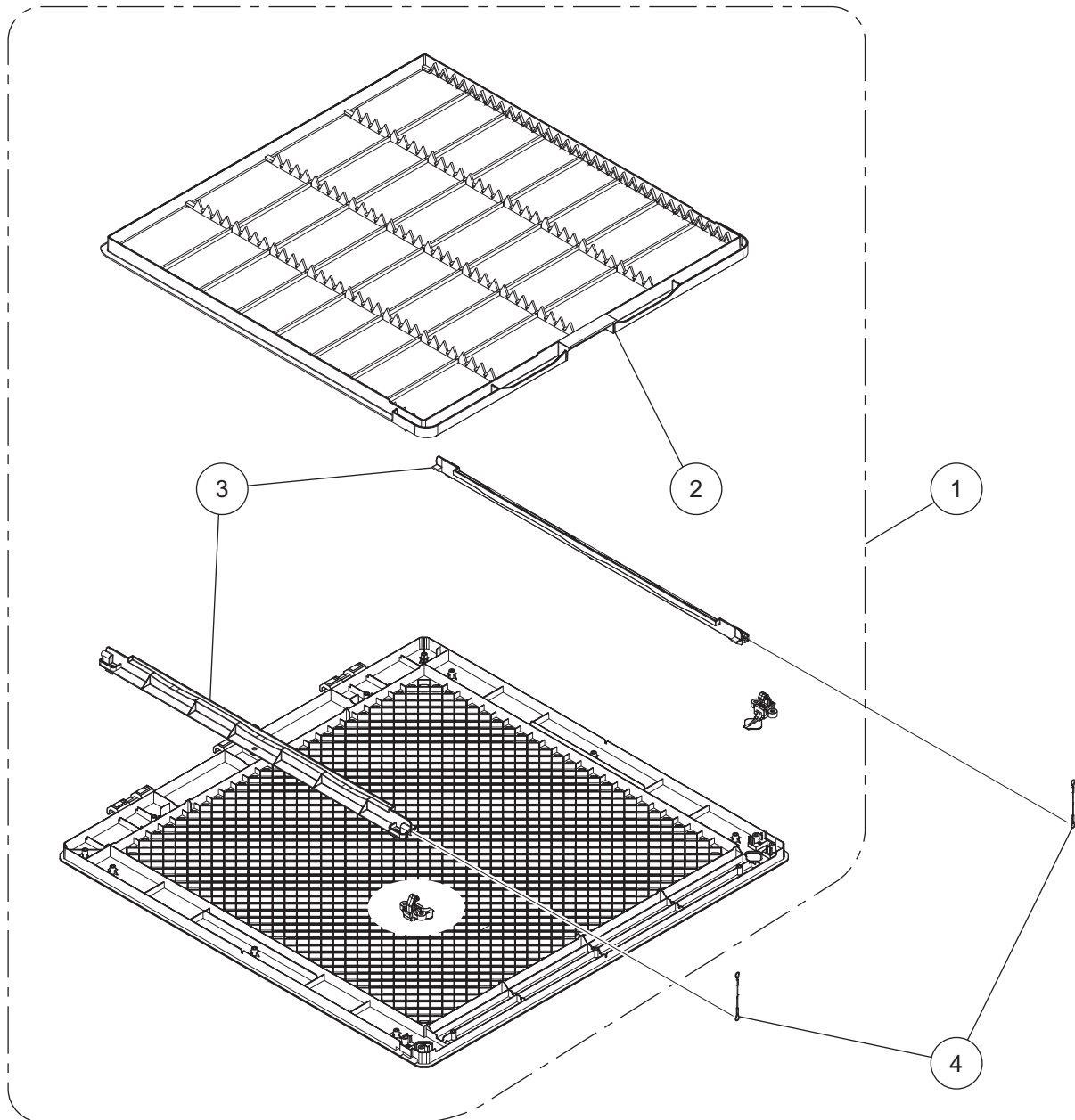

Ref No.	Description	Parts No.
1	Intake Grille Assy	9381691005
2	Long Life Filter	9378252028
3	Filter Guide	9378253018
4	Hook Wire	9378597020

■ Panels

TECHNICAL DATA
AND PARTS LIST

TECHNICAL DATA
AND PARTS LIST

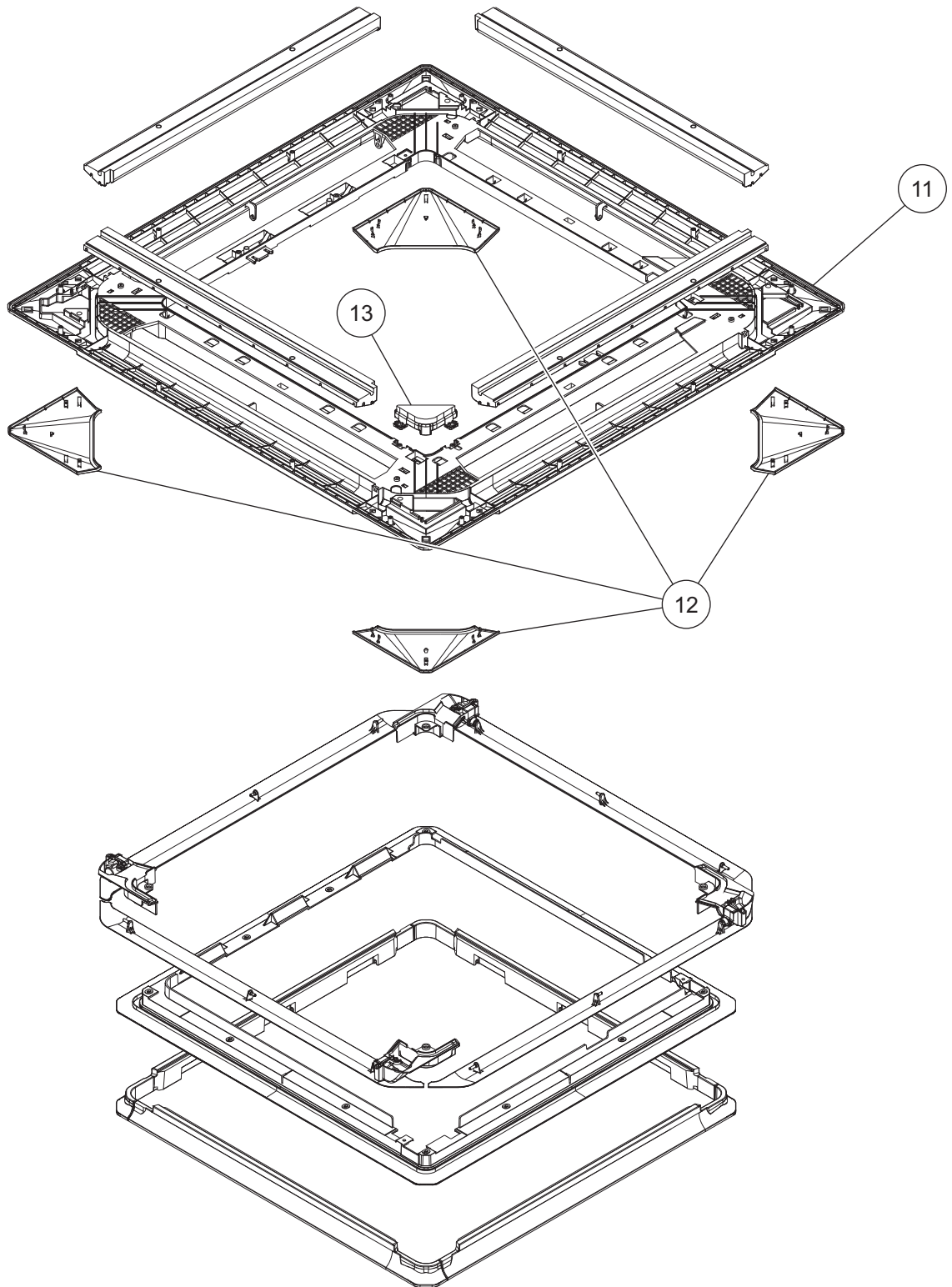

Ref No.	Description	Parts No.
11	Decoration Panel	9381352005
12	Corner Panel Assy	9381711000
13	Drain Cover Assy	9381713004

■ Louvers and motors

TECHNICAL DATA
AND PARTS LIST

TECHNICAL DATA
AND PARTS LIST

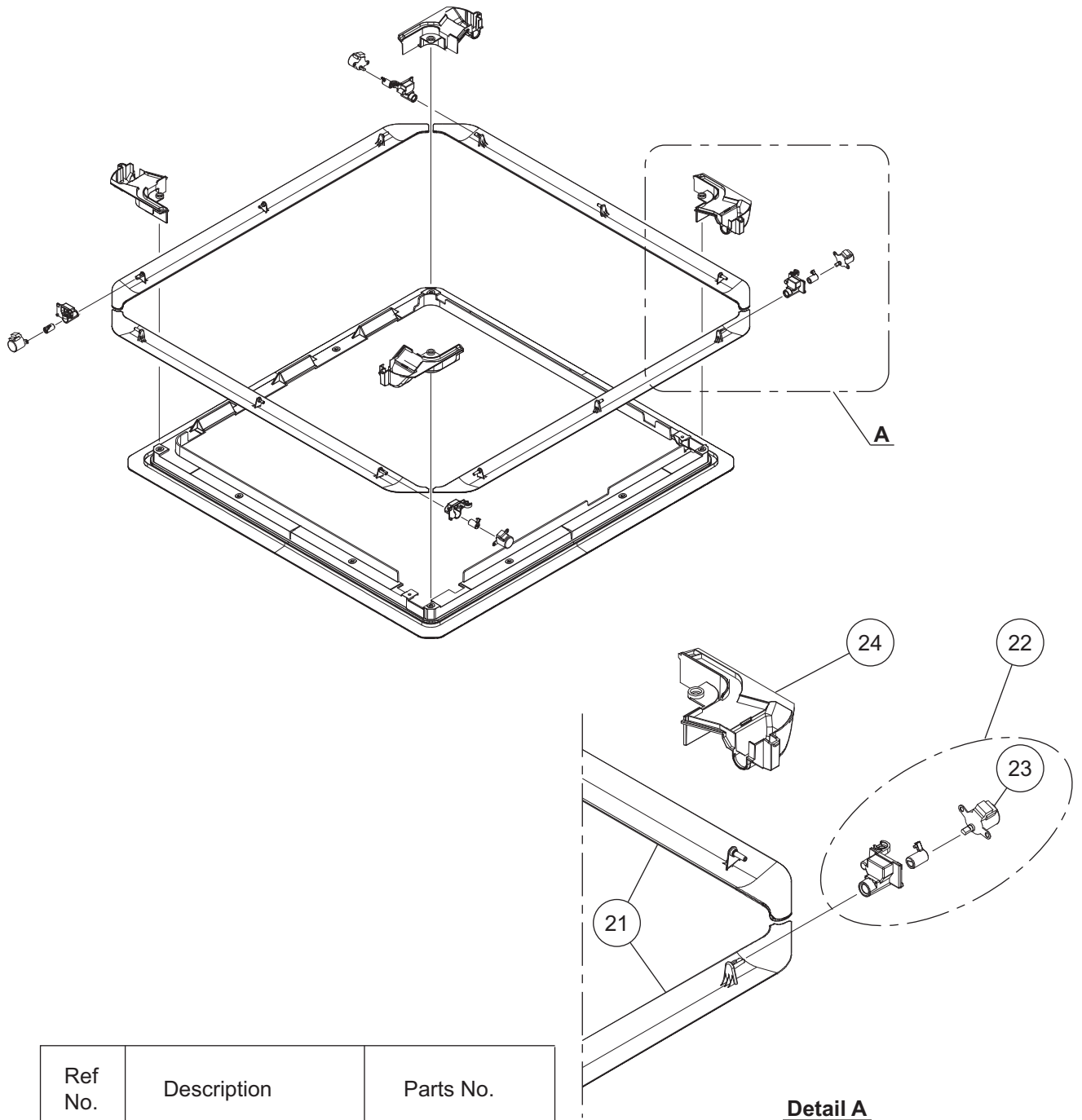

Ref No.	Description	Parts No.
21	Louver Assy	9381693009
22	Motor Case Assy	9381712007
23	Step Motor	9900885007
24	Motor Cover	9381354009
	Wire (Step Motor)	9710175008

Detail A

3. Indoor unit parts list

3-1. Models: AUXG36KRLB, AUXG45KRLB, and AUXG54KRLB

■ Miscellaneous parts

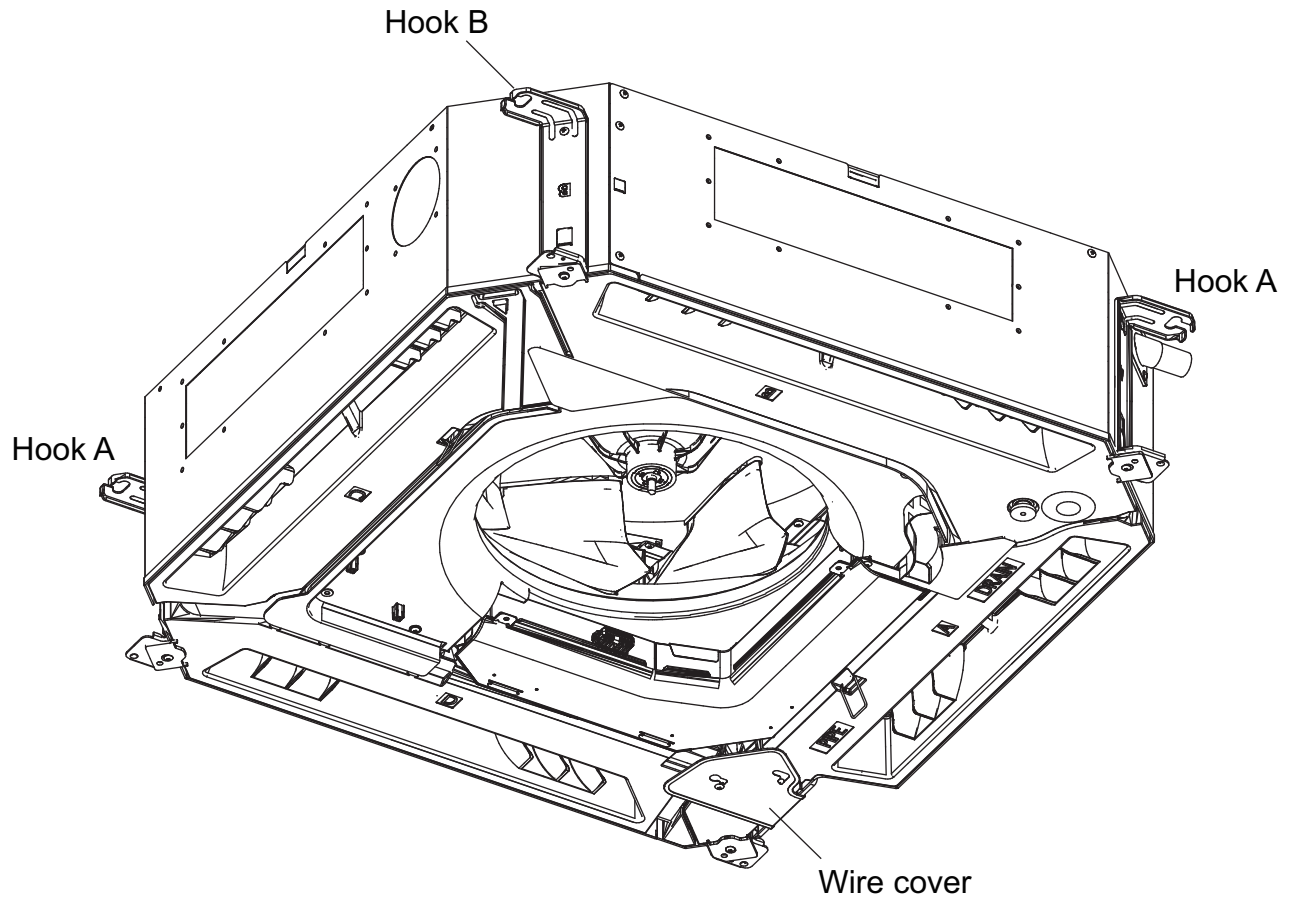

■ Main PC board

TECHNICAL DATA
AND PARTS LIST

TECHNICAL DATA
AND PARTS LIST

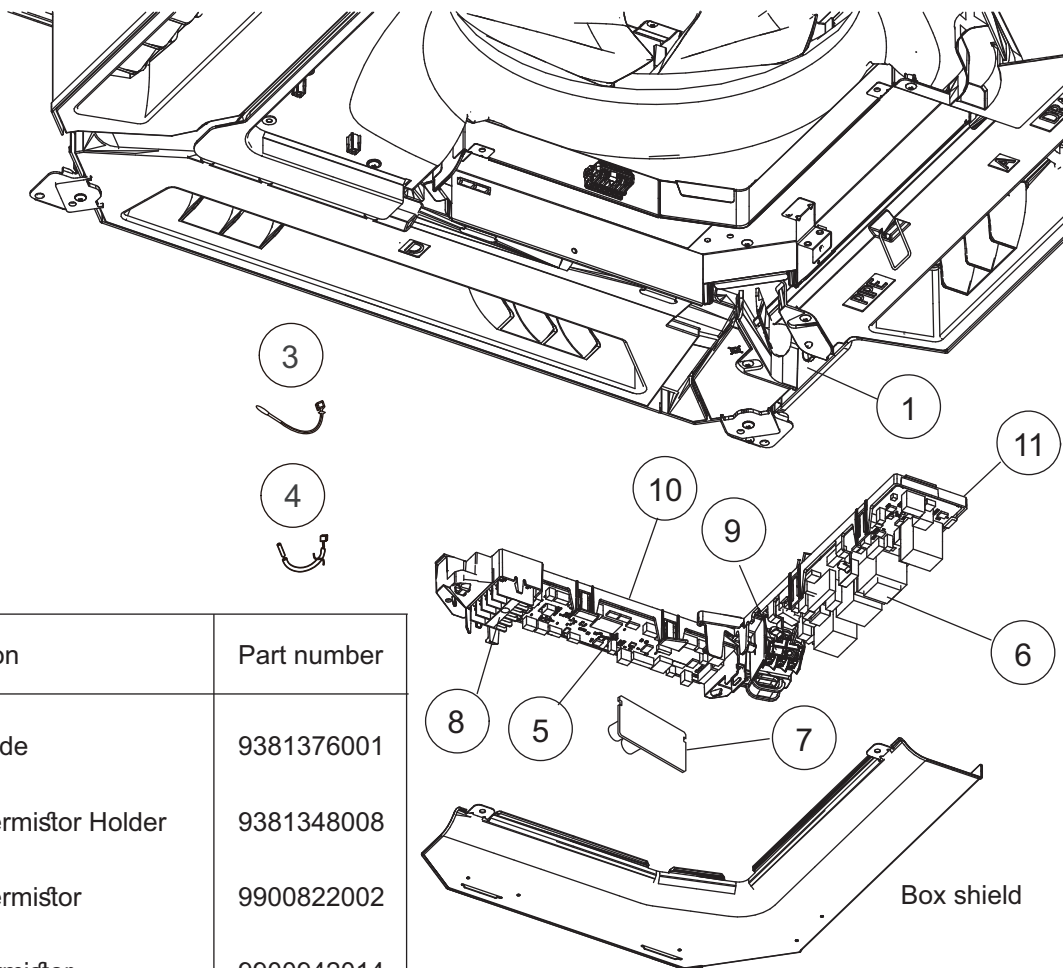

Ref.	Description	Part number
1	Cable guide	9381376001
2	Room thermistor Holder	9381348008
3	Room thermistor	9900822002
4	Pipe Thermistor	9900942014
5	Main PCB (AUXG24KRLB)	9710995873
5	Main PCB (AUXG30KRLB)	9710995880
5	Main PCB (AUXG36KRLB)	9710995897
5	Main PCB (AUXG45KRLB)	9710995903
5	Main PCB (AUXG54KRLB)	9710995910
6	Power PCB	9710022005
7	PCB (Non-polar 2-wire)	9710019005
8	Remote terminal 5P	9900896003
9	Power Terminal 3P	9900720032
10	Main PCB holder	9381350001
11	Power PCB Holder	9381349005

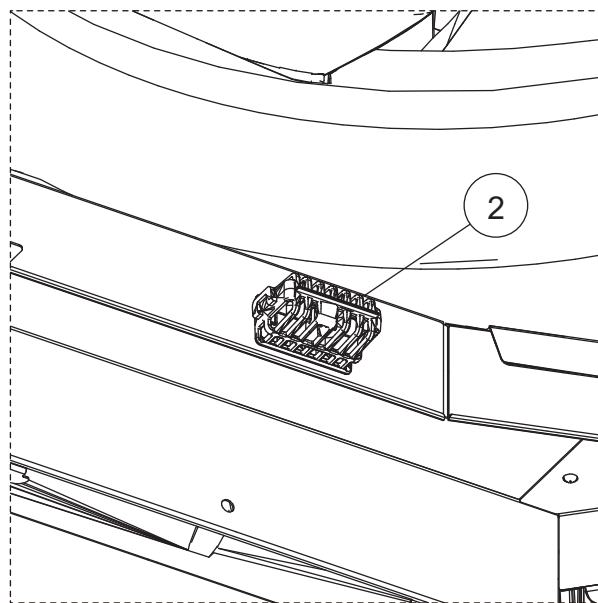

Fan and motor

TECHNICAL DATA
AND PARTS LIST

TECHNICAL DATA
AND PARTS LIST

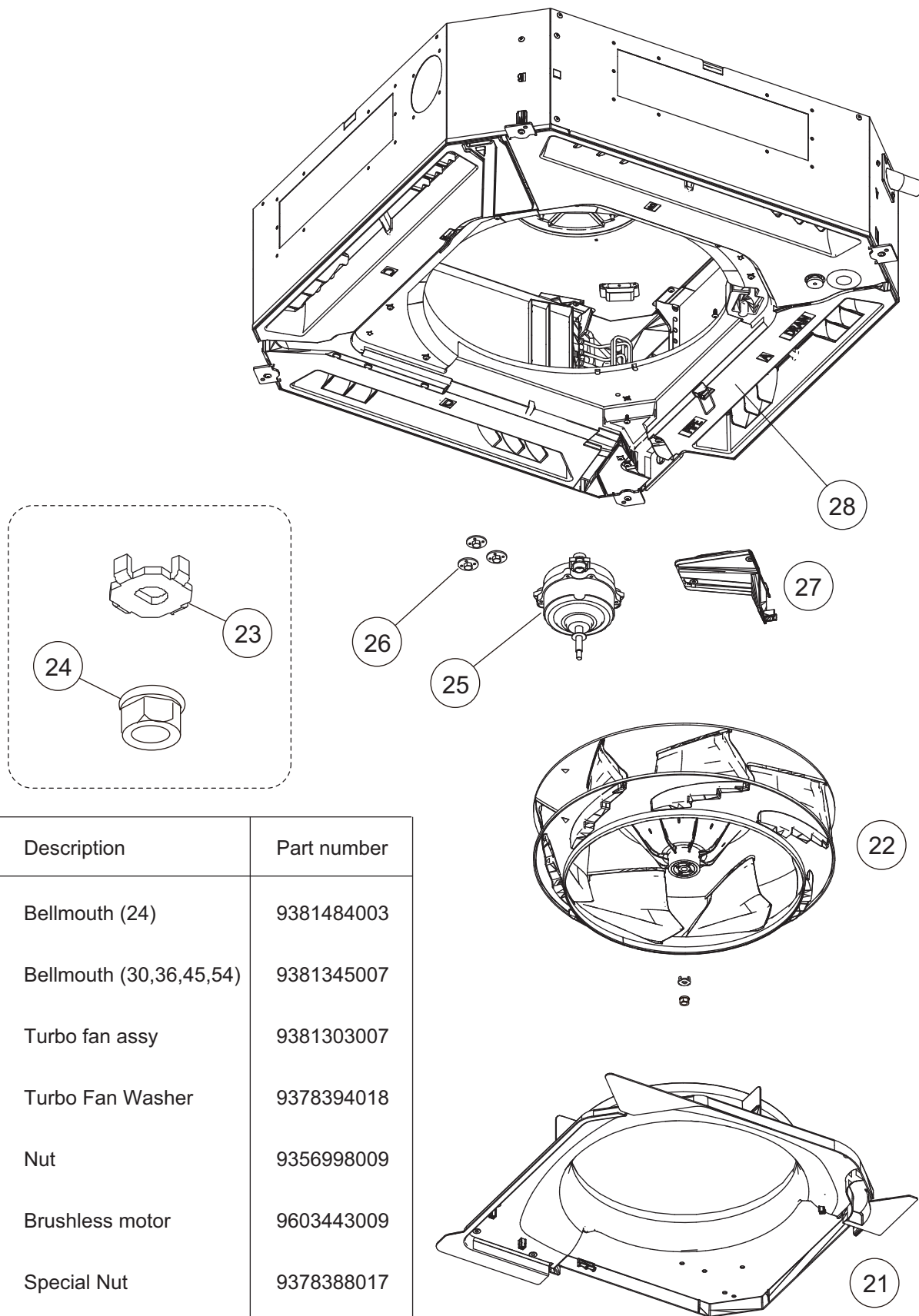

Ref.	Description	Part number
21	Bellmouth (24)	9381484003
21	Bellmouth (30,36,45,54)	9381345007
22	Turbo fan assy	9381303007
23	Turbo Fan Washer	9378394018
24	Nut	9356998009
25	Brushless motor	9603443009
26	Special Nut	9378388017
27	Motor Wire Holder	9381351008
28	Drain pan sub assy	9381789009

■ Drain pump

TECHNICAL DATA
AND PARTS LIST

TECHNICAL DATA
AND PARTS LIST

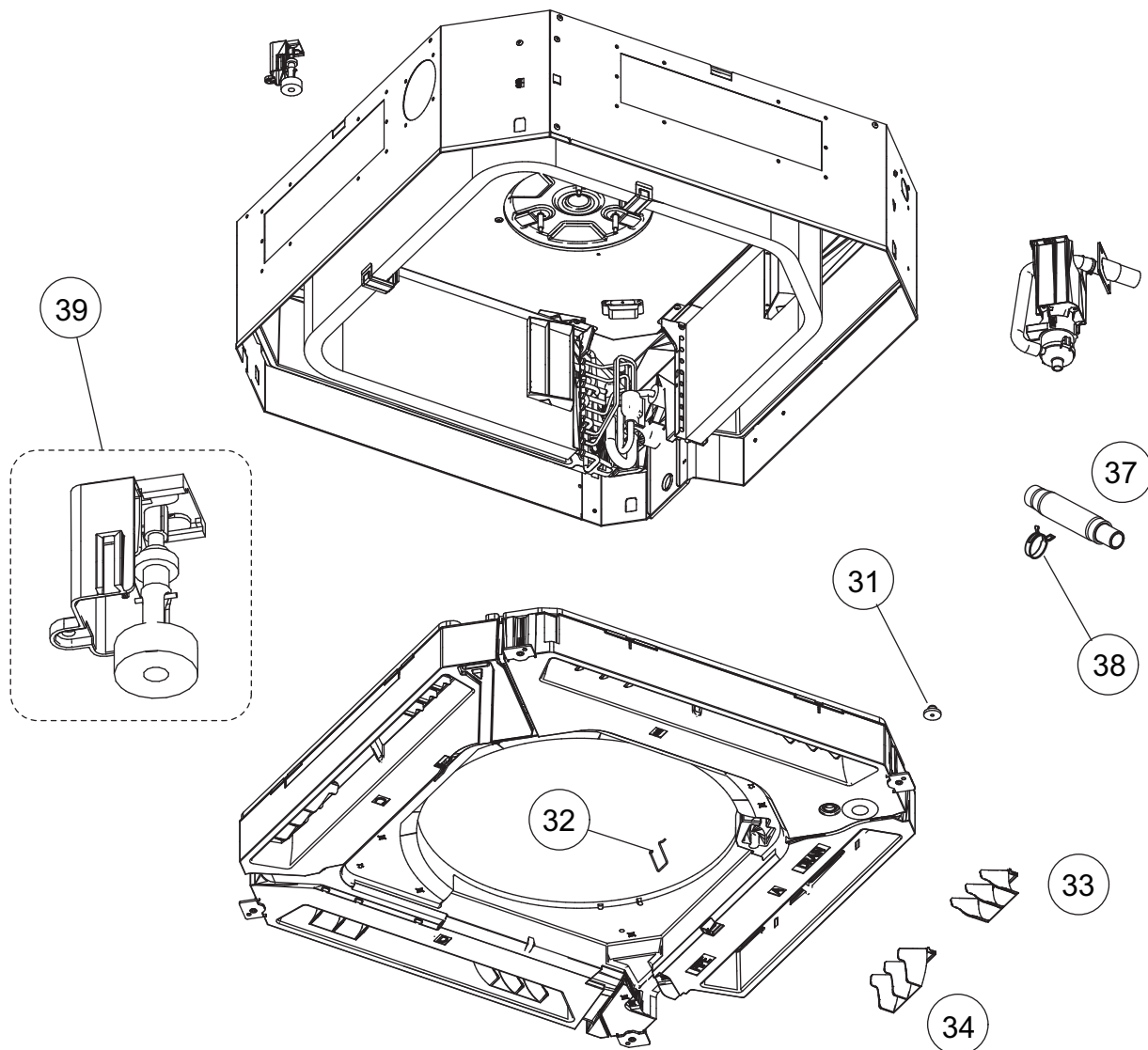

Ref.	Description	Part number
31	Drain Cap	9375502010
32	Panel Hook	9375671013
33	Vane L	9381745012
34	Vane R	9381744008
35	Drain Pump Sub Assy	9381793006
36	Drain Port Sub Assy	9381788002
37	Drain Hose	9379665001
38	Hose Band	9379757010
39	Float Switch Sub Assy	9381794003

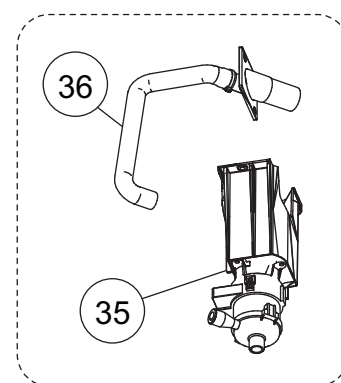

Evaporator

TECHNICAL DATA
AND PARTS LIST

TECHNICAL DATA
AND PARTS LIST

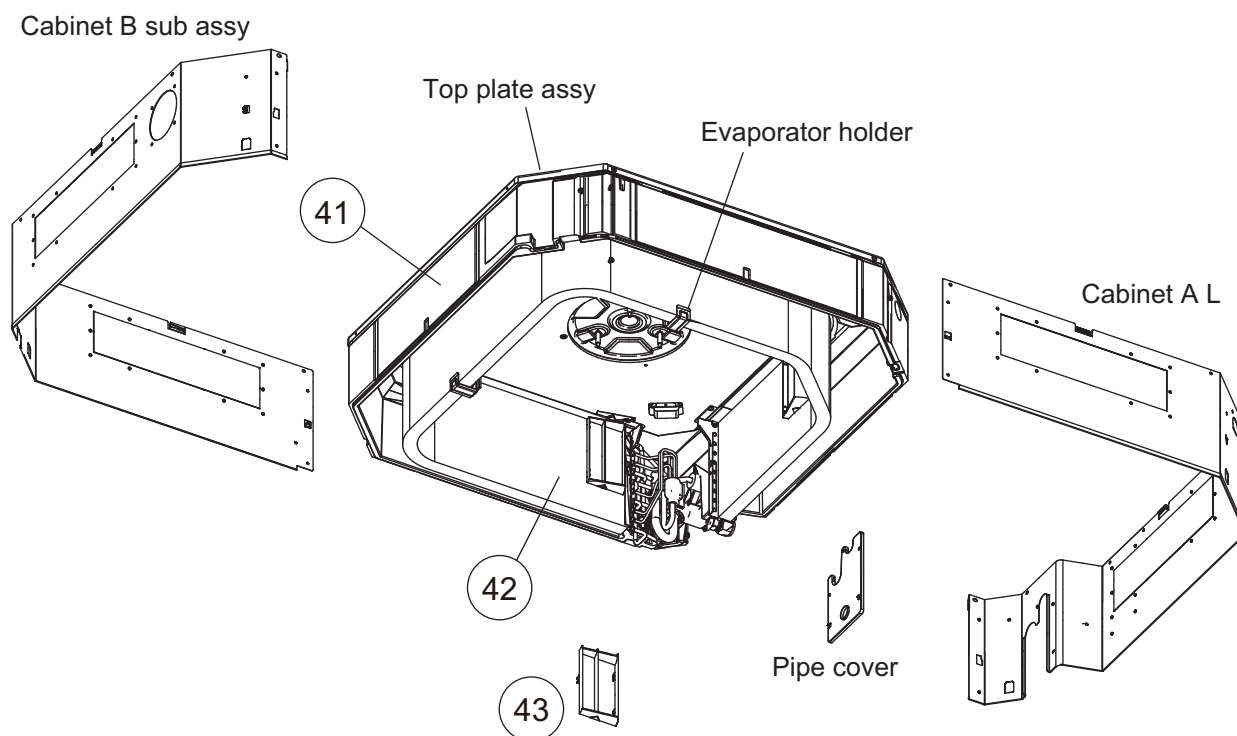

Ref.	Description	Part number
41	Insulation Box Sub Assy (24)	9381787012
41	Insulation Box Sub Assy (30,36,45,54)	9381787005
42	Evaporator Total Assy (24)	9378580664
42	Evaporator Total Assy (30)	9378580671
42	Evaporator Total Assy (36,45,54)	9378580688
43	Wind Guide Board	9382125004

4. Outdoor unit parts list

4-1. Model: AOYG36KRTA

■ Exterior parts and chassis

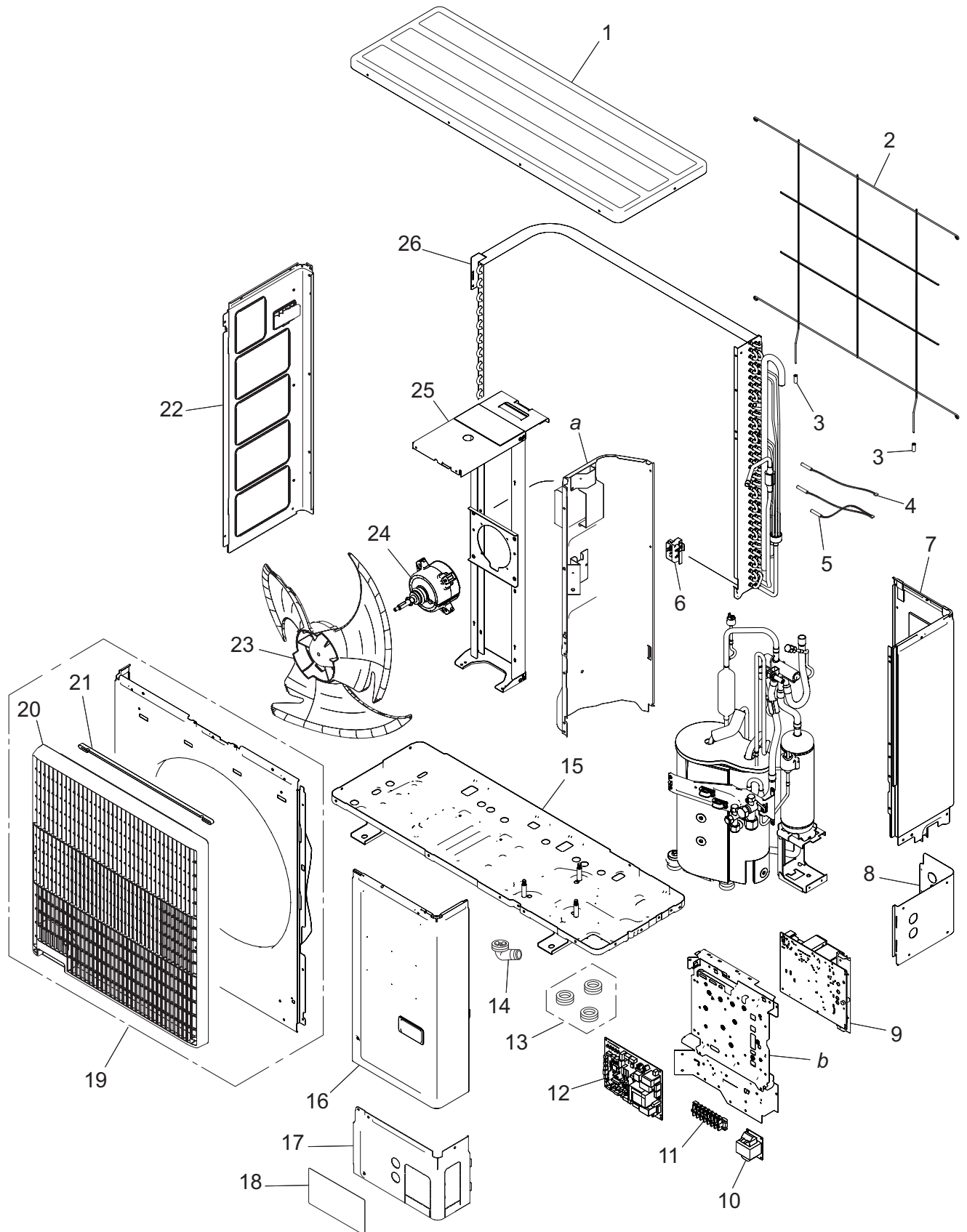

TECHNICAL DATA
AND PARTS LIST

TECHNICAL DATA
AND PARTS LIST

Item no.	Part no.	Part name	Service part
1	9383880001	Top panel assy	◆
2	9383779008	Protective net	◆
3	9375361013	Net rubber	◆
4	9900984038	Thermistor (Heat exchanger)	◆
5	9900727154	Thermistor assy	◆
6	9383607004	Thermo holder	◆
7	9383874000	Right panel sub assy	◆
8	9383879005	Rear pipe cover	◆
9	9711424006	Inverter PCB	◆
10	9900634025	Reactor assy	◆
11	9901053016	Terminal	◆
12	9711431080	Main PCB (Service)	◆
13	313166024302	Drain cap	◆
14	9303029015	Drain assy	◆
15	9350255009	Base assy (Service)	◆
16	9383876004	Service panel sub assy	◆
17	9383878008	Front pipe cover	◆
18	9351355005	Emblem rear	◆
19	9383863004	Front panel assy	◆
20	9383604003	Blow grille	◆
21	9383689000	Blow grille insulation	◆
22	9383882005	Left panel sub assy	◆
23	9383336003	Propeller fan	◆
24	9603732011	Brushless motor	◆
25	9383862007	Motor bracket assy	◆
26	9374420612	Condenser sub assy	◆
<i>a</i>	—	Separate wall assy	—
<i>b</i>	—	Control box unit	—

Compressor

TECHNICAL DATA
AND PARTS LIST

TECHNICAL DATA
AND PARTS LIST

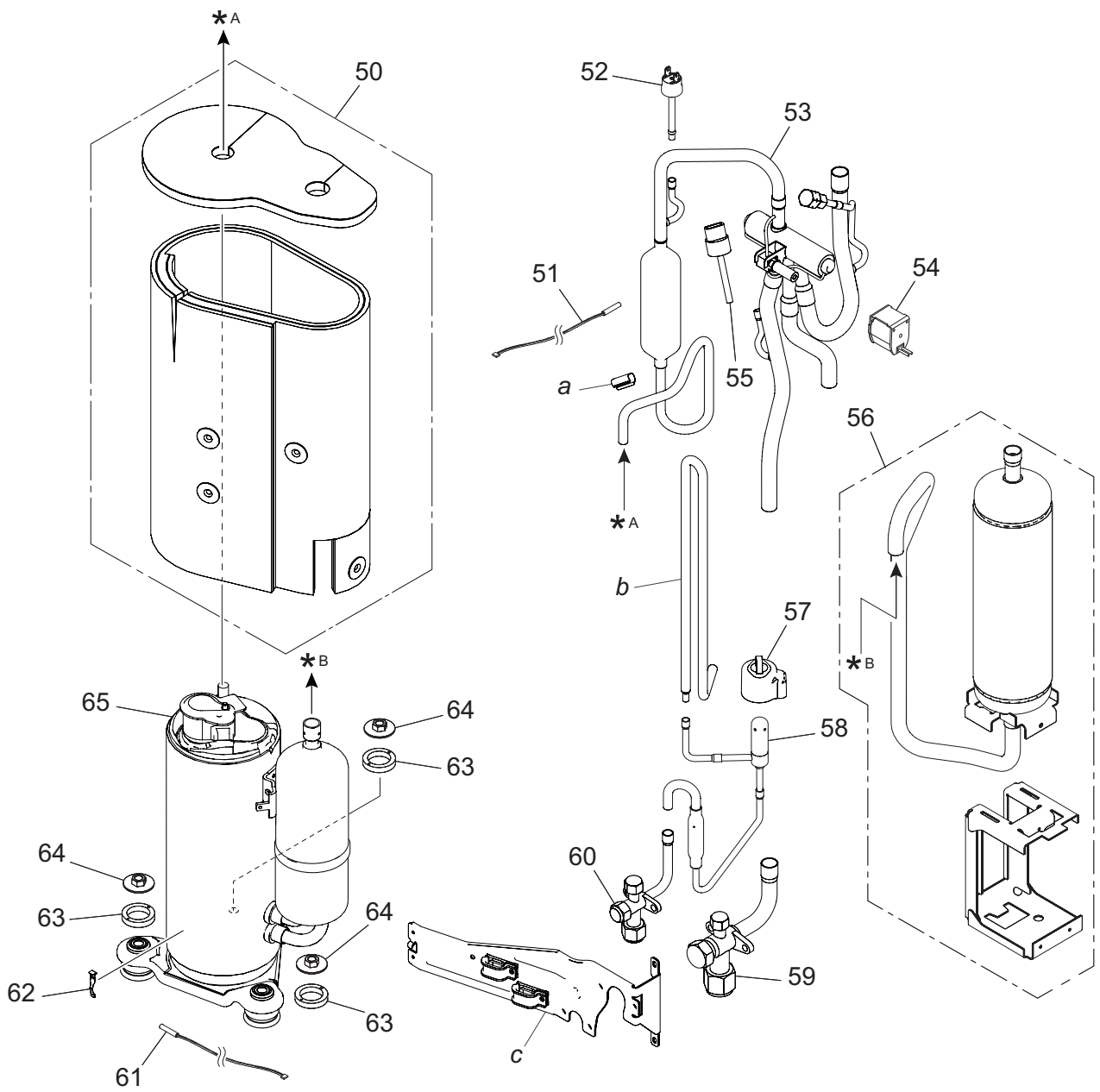

Item no.	Part no.	Part name	Service part
50	9383858000	Sound insulation unit	◆
51	9900565091	Thermistor (Outdoor temp.)	◆
52	9900186029	Pressure switch	◆
53	9374425631	4-way valve assy	◆
54	9970194016	Solenoid	◆
55	9970158018	Sensor	◆
56	9384848017	Accumulator assy (service)	◆
57	9970209000	Expansion valve coil	◆
58	9370947328	Expansion valve assy	◆
59	9379079013	3-way valve assy	◆
60	9377958037	3-way valve assy	◆
61	9900985035	Thermistor (Compressor)	◆
62	9810028006	Thermistor stopper	◆
63	9379179072	Rubber washer E	◆
64	9377973016	Special nut	◆
65	9383821011	Compressor assy	◆
<i>a</i>	—	Thermostat holder	—
<i>b</i>	—	Joint pipe D	—
<i>c</i>	—	Wiring fixation unit	—

4-2. Models: AOYG45KRTA and AOYG54KRTA

■ Exterior parts and chassis

TECHNICAL DATA
AND PARTS LIST

TECHNICAL DATA
AND PARTS LIST

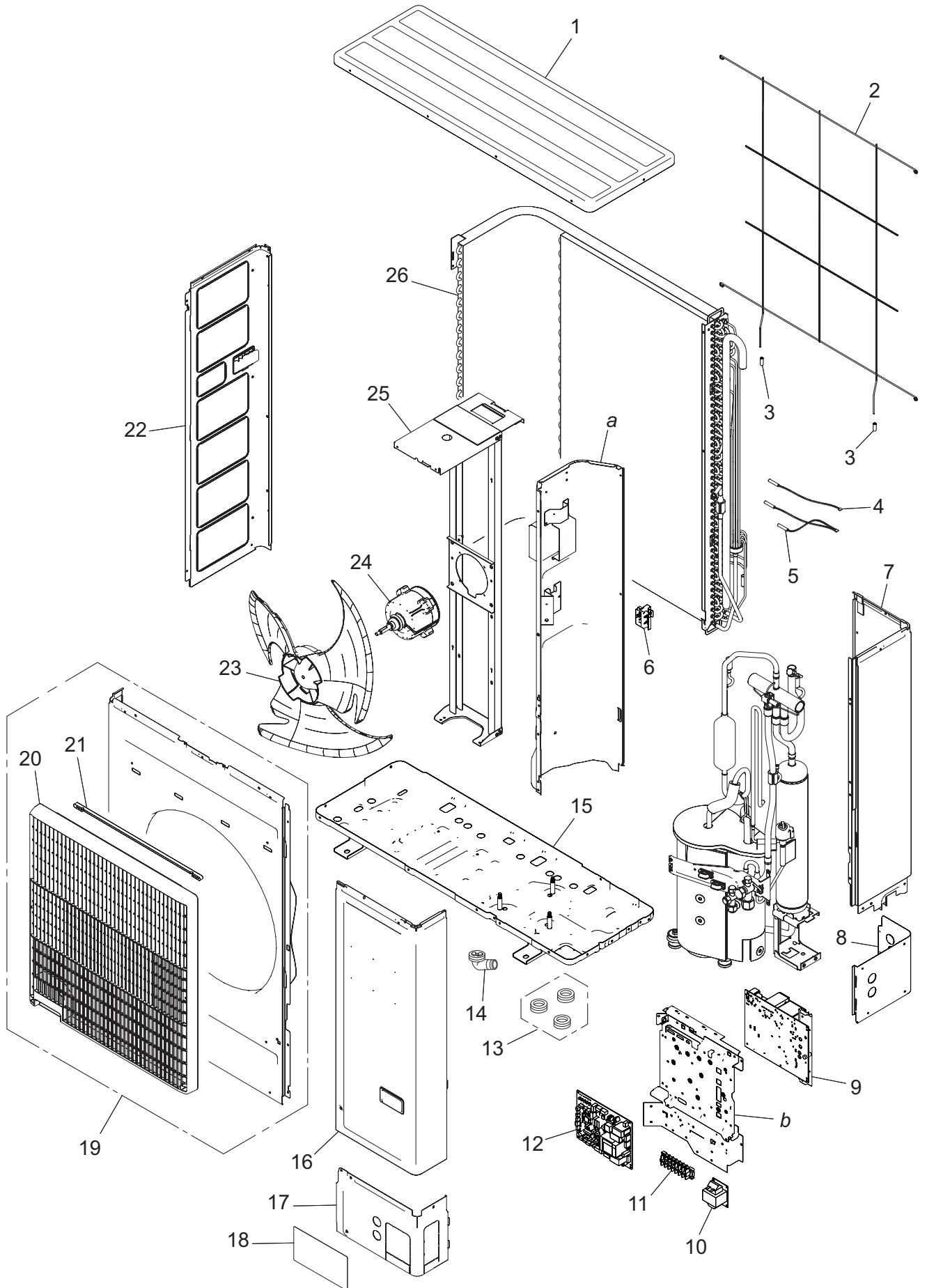

Item no.	Part no.	Part name	Service part
1	9383880001	Top panel assy	◆
2	9381013005	Protective net	◆
3	9375361013	Net rubber	◆
4	9900984038	Thermistor (Heat exchanger)	◆
5	9900727154	Thermistor assy	◆
6	9383607004	Thermo holder	◆
7	9383874017	Right panel sub assy	◆
8	9383879005	Rear pipe cover	◆
9	9711424013	Inverter PCB	◆
10	9900634025	Reactor assy	◆
11	9901053016	Terminal	◆
12	9711431097	Main PCB (Service) (for 45 model)	◆
	9711431103	Main PCB (Service) (for 54 model)	◆
13	313166024302	Drain cap	◆
14	9303029015	Drain assy	◆
15	9350255009	Base assy (Service)	◆
16	9383876011	Service panel sub assy	◆
17	9383878008	Front pipe cover	◆
18	9351355005	Emblem rear	◆
19	9383863011	Front panel assy	◆
20	9383604003	Blow grille	◆
21	9383689000	Blow grille insulation	◆
22	9383882012	Left panel sub assy	◆
23	9383336003	Propeller fan	◆
24	9603733018	Brushless motor	◆
25	9383862014	Motor bracket assy	◆
26	9374420605	Condenser sub assy	◆
<i>a</i>	—	Separate wall assy	—
<i>b</i>	—	Control box unit	—

Compressor

TECHNICAL DATA
AND PARTS LIST

TECHNICAL DATA
AND PARTS LIST

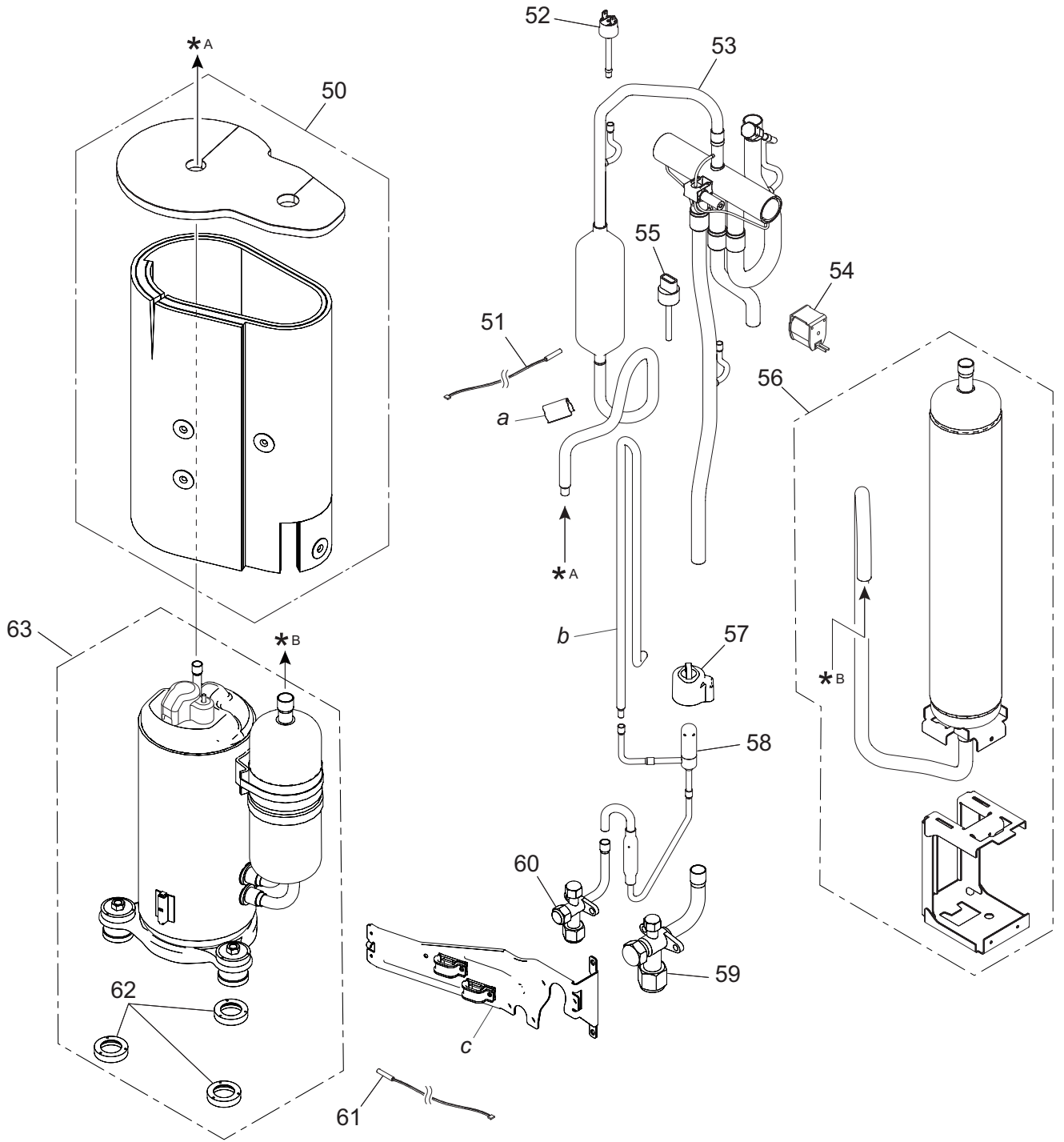







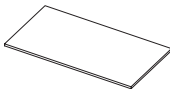
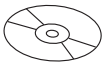
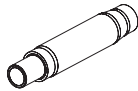

Item no.	Part no.	Part name	Service part
50	9383858017	Sound insulation unit	◆
51	9900565091	Thermistor (Outdoor temp.)	◆
52	9900186029	Pressure switch	◆
53	9374425624	4-way valve assy	◆
54	9970194016	Solenoid	◆
55	9970158018	Sensor	◆
56	9384848000	Accumulator assy (Service)	◆
57	9970209000	Expansion valve coil	◆
58	9370947311	Expansion valve assy	◆
59	9379079013	3-way valve assy	◆
60	9377958037	3-way valve assy	◆
61	9900985028	Thermistor (Compressor)	◆
62	9379179089	Rubber washer F	◆
63	9383851131	Compressor unit	◆
<i>a</i>	—	Thermistor spring	—
<i>b</i>	—	Joint pipe D	—
<i>c</i>	—	Wiring fixation unit	—

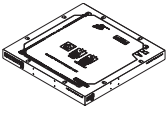
5. Accessories



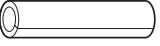

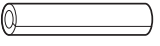
5-1. Indoor unit

■ Models: AUXG36KRLB, AUXG45KRLB, and AUXG54KRLB

Part name	Exterior	Q'ty	Part name	Exterior	Q'ty
Operating manual		1	Insulation		1
Operating manual (CD-ROM)		1	Drain hose		1
Installation manual		1	Hose band		1
Template (Carton top)		1	Drain hose heat insulation		1
Washer		8	Cable tie (large)		4
Coupler heat insulation (large)		1	Cable tie (small)		2
Coupler heat insulation (small)		1			

5-2. Outdoor unit



■ Models: AOYG36KRTA, AOYG45KRTA, and AOYG54KRTA

Part name	Exterior	Q'ty	Part name	Exterior	Q'ty
Installation manual		1	Drain cap		3
Drain pipe		1	One-touch bush		2

6. Optional parts

6-1. Indoor unit

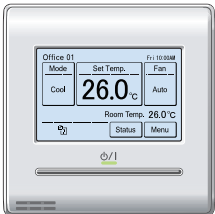
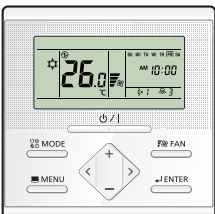
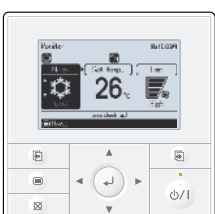
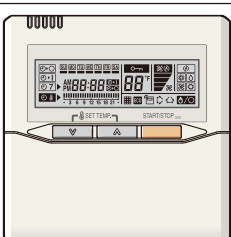

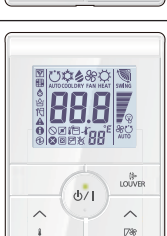
■ Controllers

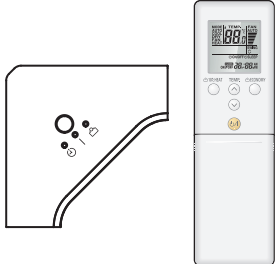
Exterior	Part name	Model name	Summary
	Wired remote controller	UTU-RNRYZ*	Easy finger touch operation with LCD panel. Backlit LCD enables easy operation in a dark room. Wire type: Non-polar 2-wire
	Wired remote controller	UTU-RLRY	High visibility and easy operation. Room temperature can be accurately controlled using the built-in thermo sensor. Wire type: Non-polar 2-wire
	Wired remote controller	UTU-RVNYM	Large and full-dot liquid crystal screen, wide and large keys easy to press, user-intuitive arrow key. Wire type: Polar 3-wire
	Wired remote controller	UTU-RNNYM	Room temperature can be controlled by detecting the temperature accurately with built-in thermo sensor. Wire type: Polar 3-wire
	Simple remote controller	UTU-RSRY	Compact remote controller concentrates on the basic functions such as Start/Stop, fan control, temperature setting, and operation mode. Wire type: Non-polar 2-wire
	Simple remote controller	UTU-RHRY	Compact remote controller concentrates on the basic functions such as Start/Stop, fan control, and temperature setting. Wire type: Non-polar 2-wire



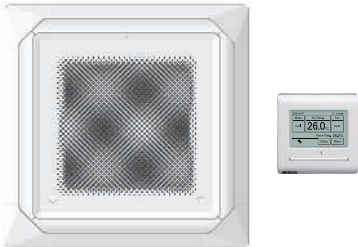

Exterior	Part name	Model name	Summary
	Simple remote controller	UTY-RSNYM	Compact remote controller concentrates on the basic functions such as Start/Stop, fan control, temperature setting, and operation mode. Wire type: Polar 3-wire
	IR receiver kit with wireless remote controller	UTY-LBTYC	Unit control is performed by wireless remote controller.

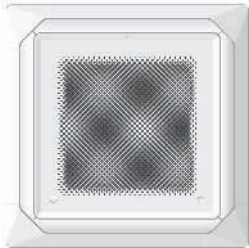

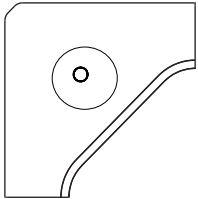
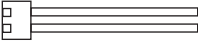

NOTE: Available functions may differ by the remote controller. For details, refer to the operation manual.

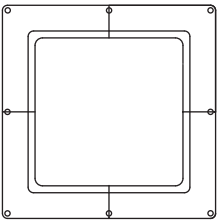
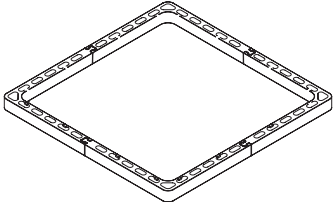
■ Cassette grille

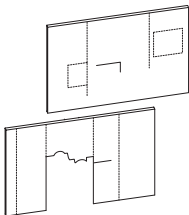
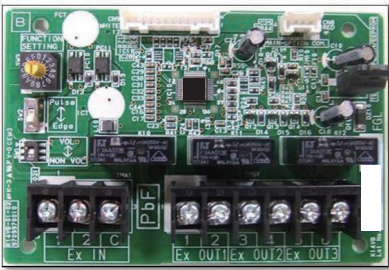
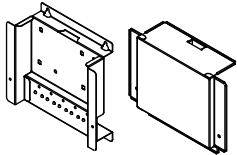
Exterior	Part name	Model name	Summary
	Cassette grille	UTG-UKYA-W	This cassette grille to blow airflow in 360° direction by unique seamless airflow louver design. Wired remote controller (UTY-RNRYZ*) is included.
	Cassette grille	UTG-UKYA-B	This cassette grille to blow airflow in 360° direction by unique seamless airflow louver design. Black color model.
	Cassette grille	UTG-UKYC-W	This cassette grille to blow airflow in 360° direction by unique seamless airflow louver design.

Others

Exterior	Part name	Model name	Summary
	Human sensor kit	UTY-SHZXC	For circular flow cassette type.
	External connect kit	UTY-XWZXZG	Use to connect with various peripheral devices and air conditioner PCB. For control output port.
	Air outlet shutter plate	UTR-YDZK	Installed at the air outlet when 3-directions mode is performed.
	Wide panel	UTG-AKXA-W	Hides the gap between the ceiling hole and the cassette grille.
	Panel spacer	UTG-BKXA-W	If there is not enough height in the ceiling space, by inserting this spacer between the cassette grille and the ceiling surface, the height of the unit body goes into the ceiling space become 50-mm lower.
	Fresh-air intake kit	UTZ-VXRA	By attaching Fresh-air intake kit to the indoor unit, it can be taken in fresh air of up to 10% of "high" air volume of the indoor unit.
	Insulation for high humidity	UTZ-KXRA	Install when the under-roof condition is expected to be the humidity of over 80% and the temperature of over 30 °C.
	External input and output PCB	UTY-XCSX	Use to connect with external devices and air conditioner PCB.
	External input and output PCB box	UTZ-GXRA	For installing the External input and output PCB.

Exterior	Part name	Model name	Summary
	Wireless LAN adapter	UTY-TFSXZ1	Remotely manage an air conditioning system using mobile devices such as smartphones and tablets. For connection indoor unit with UART interface.
	Modbus converter	UTY-VMSX	For connection between indoor unit with UART interface and a Modbus open network.
	KNX converter	UTY-VKSX	For connection between indoor unit with UART interface and a KNX open network.
	External switch controller	UTY-TERX	Air conditioner switching can be controlled by connecting other external sensor switches.

NOTE: Combined use of following optional parts and Wireless LAN adapter (UTY-TFSXZ1) is not allowed.

- External input and output PCB (UTY-XCSX)
- Modbus converter
- KNX converter

6-2. Outdoor unit

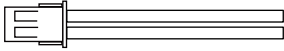
Exterior	Part name	Model name	Summary
	External connect kit	UTY-XWZXZ3	Use to operate the external input and output functions of outdoor unit.

7. Refrigerant system diagrams

7-1. Models: AOYG36KRTA, AOYG45KRTA, and AOYG54KRTA

TECHNICAL DATA
AND PARTS LIST

TECHNICAL DATA
AND PARTS LIST

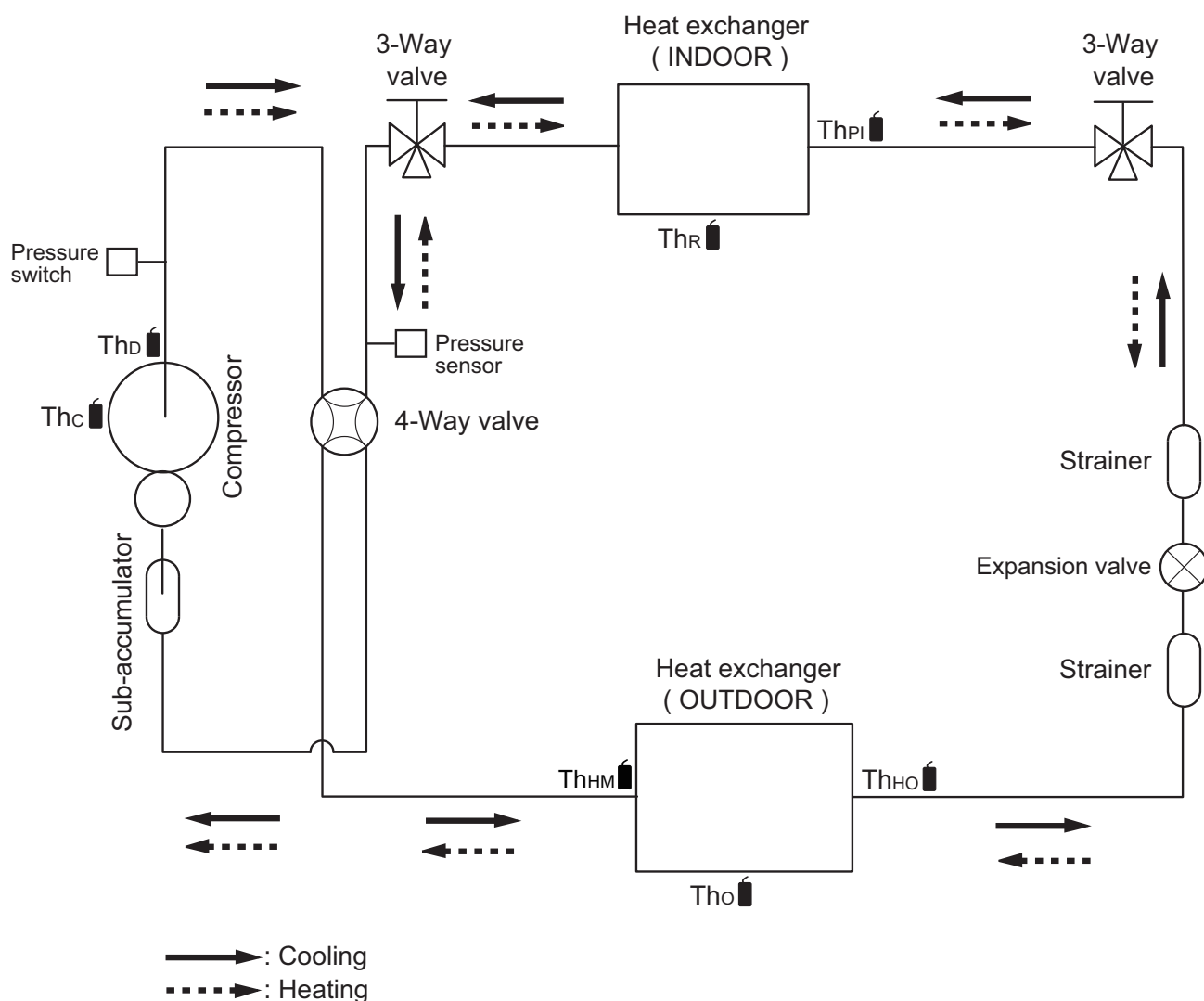

- Th_c : Thermistor (Compressor temperature)
- Th_D : Thermistor (Discharge temperature)
- Th_{HM} : Thermistor (Heat Exchanger Med temperature)
- Th_o : Thermistor (Outdoor temperature)
- Th_{HO} : Thermistor (Heat Exchanger Out temperature)
- Th_R : Thermistor (Room temperature)
- Th_{PI} : Thermistor (Pipe temperature)

8-2. Outdoor unit

Model: AOYG36KRTA

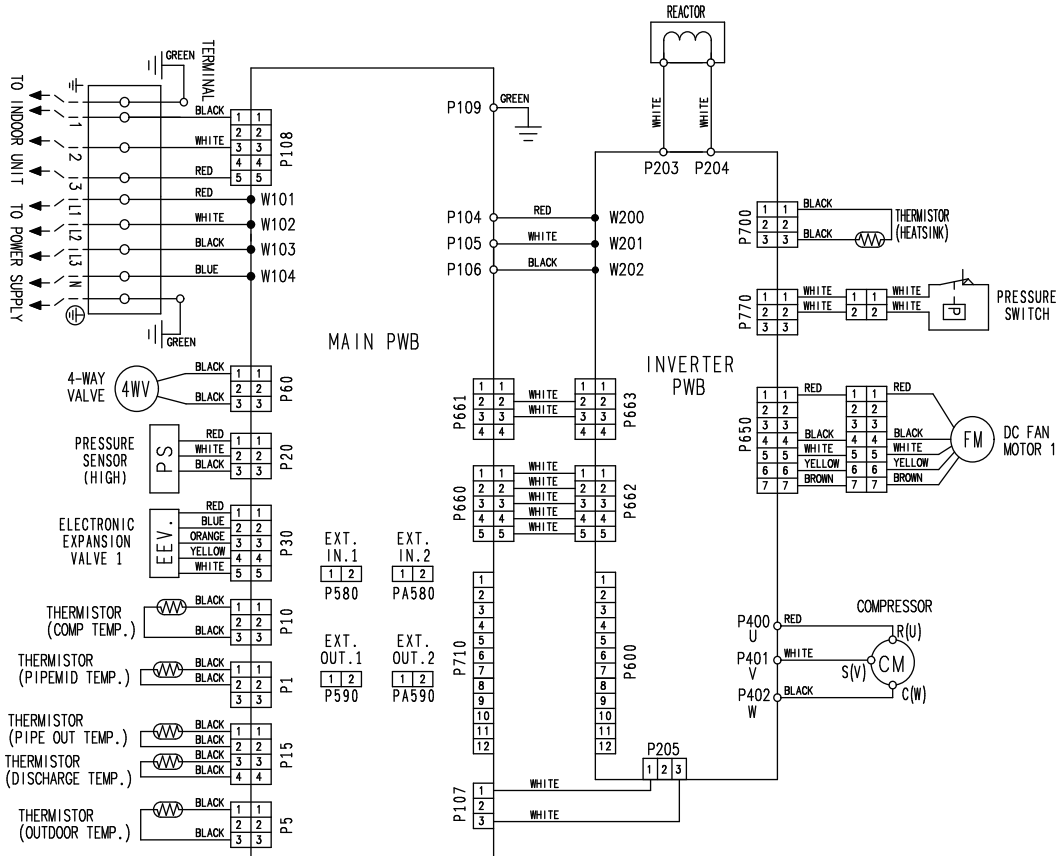

Models: AOYG45KRTA and AOYG54KRTA

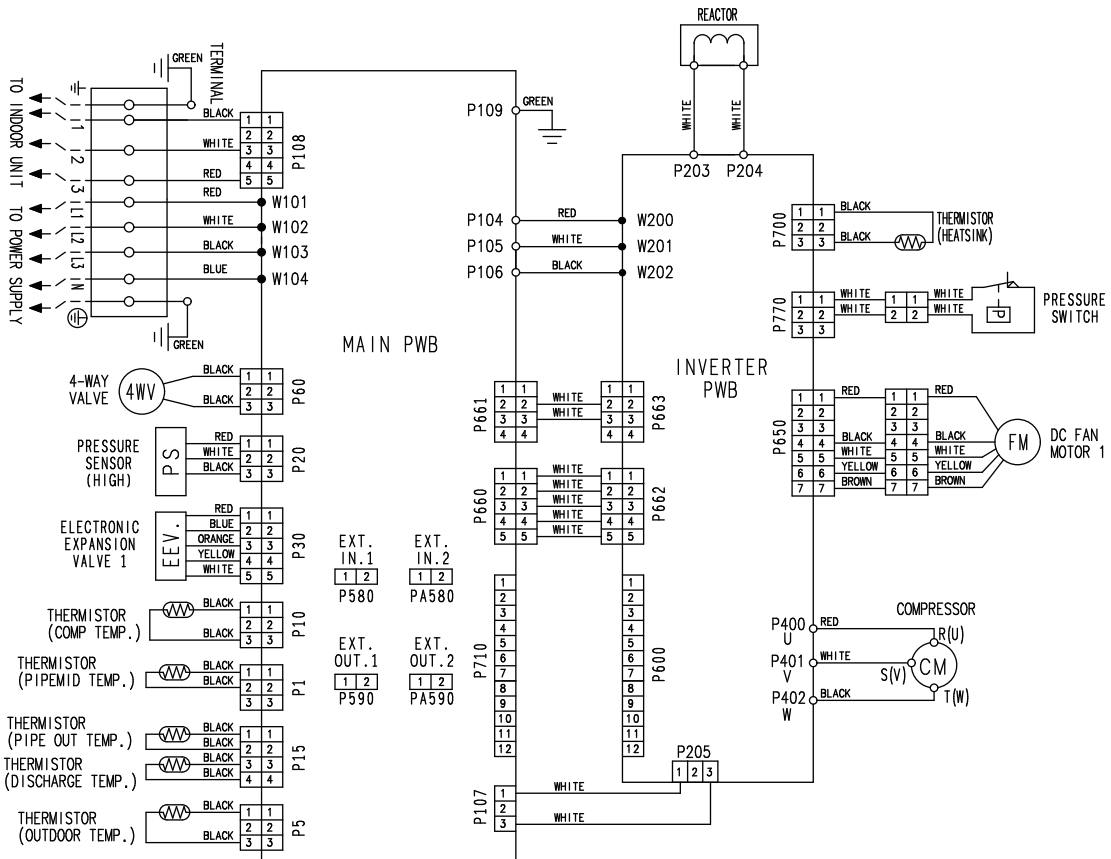

9. PC board diagrams

9-1. Models: AUXG36KRLB, AUXG45KRLB, and AUXG54KRLB

CONTROL UNIT
 24 model: EZ-01823HSE 45 model: EZ-01826HSE
 30 model: EZ-01824HSE 54 model: EZ-01827HSE
 36 model: EZ-01825HSE

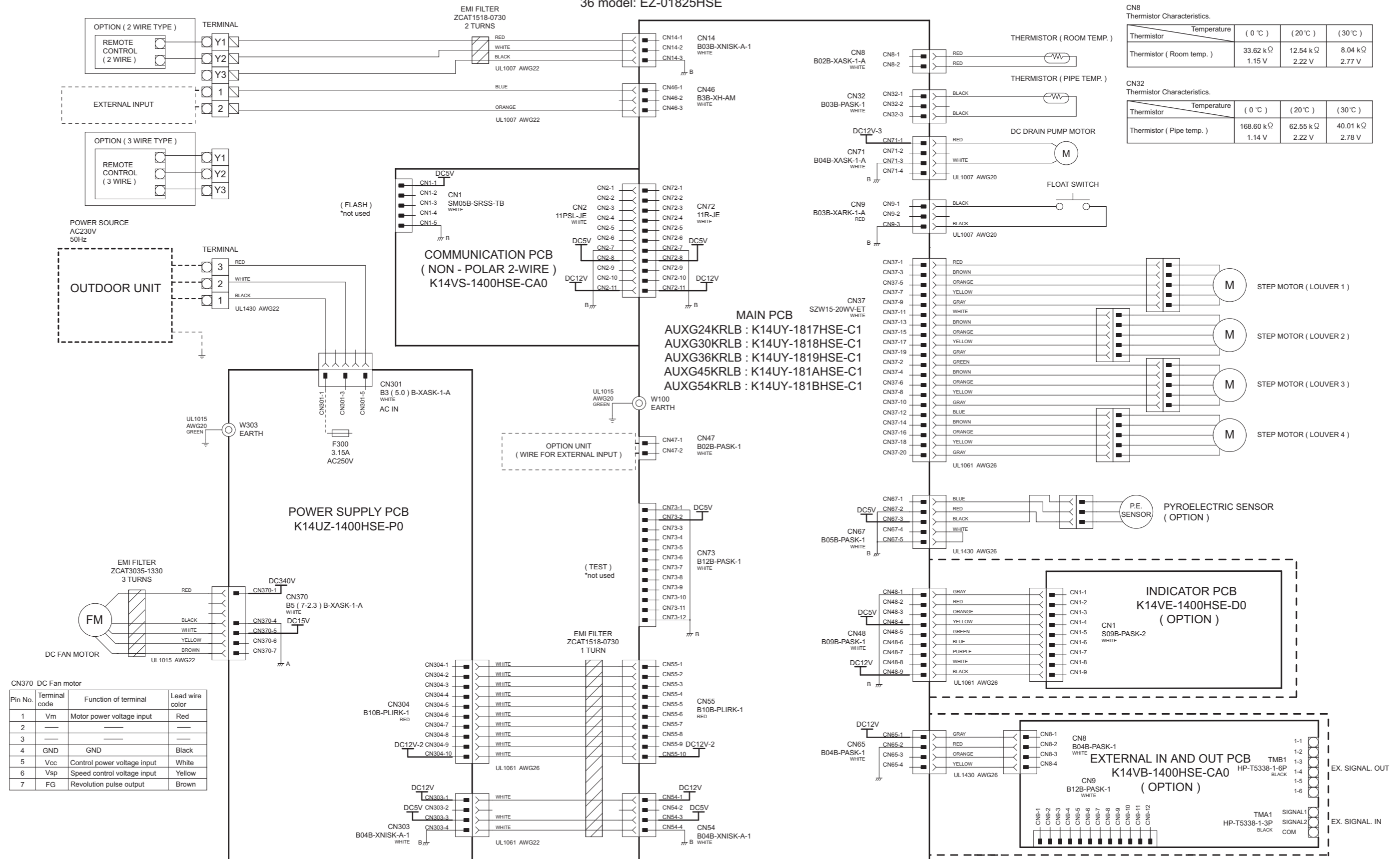

CN8 Thermistor Characteristics.

Thermistor	Temperature	(0 °C)	(20 °C)	(30 °C)
Thermistor (Room temp.)		33.62 kΩ	12.54 kΩ	8.04 kΩ
		1.15 V	2.22 V	2.77 V

CN32 Thermistor Characteristics.

Thermistor	Temperature	(0 °C)	(20 °C)	(30 °C)
Thermistor (Pipe temp.)		168.60 kΩ	62.55 kΩ	40.01 kΩ
		1.14 V	2.22 V	2.78 V

CN370 DC Fan motor

Pin No.	Terminal code	Function of terminal	Lead wire color
1	Vm	Motor power voltage input	Red
2	---	---	---
3	---	---	---
4	GND	GND	Black
5	Vcc	Control power voltage input	White
6	Vsp	Speed control voltage input	Yellow
7	FG	Revolution pulse output	Brown

TECHNICAL DATA AND PARTS LIST

TECHNICAL DATA AND PARTS LIST

9-2. Models: AOYG36KRTA, AOYG45KRTA, and AOYG54KRTA

TECHNICAL DATA AND PARTS LIST

TECHNICAL DATA AND PARTS LIST

INVERTER ASSEMBLY
 36 model: EZ-0190HUE
 45 model: EZ-0191HUE
 54 model: EZ-0191HUE

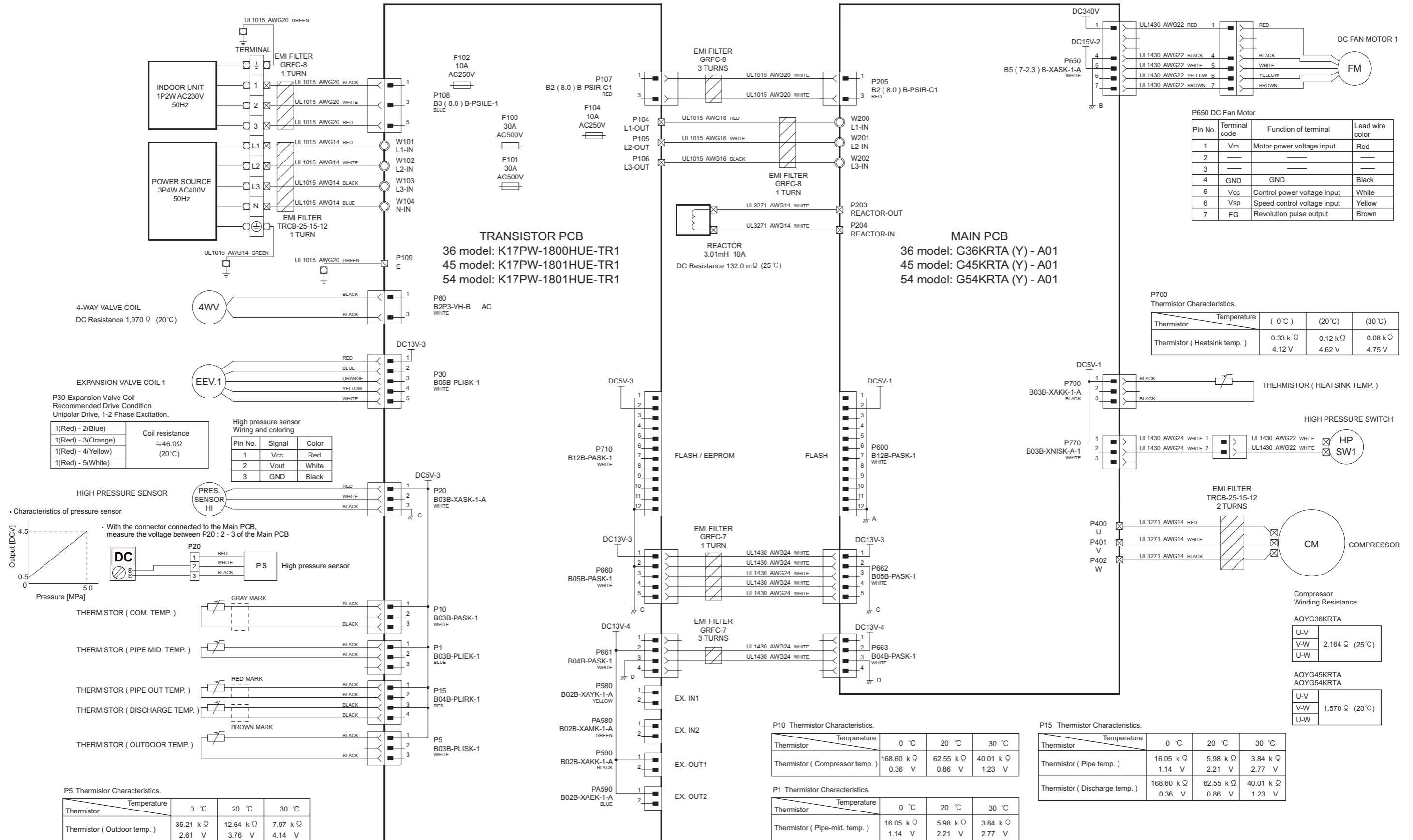

3. TROUBLESHOOTING

CONTENTS

3. TROUBLESHOOTING

1. Error code	03-1
1-1. Error code table (Wired remote controller).....	03-1
1-2. Error code table (Outdoor unit).....	03-2
2. Troubleshooting with error code	03-4
2-1. E: 11. Serial communication error (Serial reverse transfer error) (Outdoor unit).....	03-4
2-2. E: 11. Serial communication error (Serial forward transfer error) (Indoor unit)	03-6
2-3. E: 12. Wired remote controller communication error (Indoor unit)	03-8
2-4. E: 18. External communication error (Indoor unit)	03-9
2-5. E: 23. Combination error (Outdoor unit).....	03-10
2-6. E: 26. Address setting error in wired remote controller (Indoor unit).....	03-11
2-7. E: 29. Connected unit number error (Indoor unit)	03-12
2-8. E: 32. Indoor unit main PCB error (Indoor unit)	03-13
2-9. E: 33. Indoor unit motor electricity consumption detection error (Indoor unit).....	03-14
2-10. E: 35. MANUAL AUTO button error (Indoor unit).....	03-15
2-11. E: 39. Indoor unit power supply error for fan motor (Indoor unit)	03-16
2-12. E: 3A. Indoor unit communication circuit (wired remote controller) error	03-17
2-13. E: 41. Room temperature sensor error (Indoor unit).....	03-18
2-14. E: 42. Indoor unit heat exchanger sensor error (Indoor unit)	03-19
2-15. E: 51. Indoor unit fan motor error (Indoor unit)	03-20
2-16. E: 53. Drain pump error (Indoor unit).....	03-21
2-17. E: 62. Outdoor unit main PCB error (Outdoor unit).....	03-22
2-18. E: 63. Inverter error (Outdoor unit).....	03-23
2-19. E: 64. PFC circuit error (Outdoor unit)	03-24
2-20. E: 65. Trip terminal L error (Outdoor unit).....	03-25
2-21. E: 71. Discharge thermistor error (Outdoor unit).....	03-26
2-22. E: 72. Compressor thermistor error (Outdoor unit)	03-27
2-23. E: 73. Heat exchanger (Middle/Outlet) temperature thermistor error (Outdoor unit) ...	03-28
2-24. E: 74. Outdoor temperature thermistor error (Outdoor unit).....	03-29
2-25. E: 77. Heat sink thermistor error (Outdoor unit).....	03-30
2-26. E: 84. Current sensor error (Outdoor unit)	03-31
2-27. E: 86. High pressure switch error (Outdoor unit)	03-32
2-28. E: 94. Trip detection (Outdoor unit).....	03-33
2-29. E: 95. Compressor motor control error (Outdoor unit)	03-34
2-30. E: 97. Outdoor unit fan motor error (Outdoor unit).....	03-35
2-31. E: 99. 4-way valve error (Outdoor unit).....	03-36
2-32. E: A1. Discharge temperature error (Outdoor unit).....	03-38
2-33. E: A3. Compressor temperature error (Outdoor unit).....	03-40
2-34. E: A5. Low pressure error (Outdoor unit).....	03-42
2-35. E: AC. Heat sink temperature error (Outdoor unit).....	03-44
3. Troubleshooting without error code	03-45
3-1. Indoor unit—No power.....	03-45
3-2. Outdoor unit—No power	03-46

CONTENTS (continued)

3-3. No operation (Power is on)	03-47
3-4. No cooling/No heating	03-48
3-5. Abnormal noise.....	03-50
3-6. Water leaking.....	03-51
4. Service parts information	03-52
4-1. Compressor	03-52
4-2. Inverter compressor.....	03-53
4-3. Outdoor unit Electronic Expansion Valve (EEV)	03-55
4-4. Indoor unit fan motor	03-57
4-5. Outdoor unit fan motor.....	03-58
4-6. Pressure switch	03-59
4-7. 4-way valve coil (solenoid coil)/4-way valve	03-60
5. Thermistor resistance values.....	03-61
5-1. Indoor unit	03-61
5-2. Outdoor unit.....	03-62

1. Error code

1-1. Error code table (Wired remote controller)

The operation, timer, and economy indicators operate according to the error contents.
For confirmation of the error contents, refer the flashing pattern as follows.

Error contents	Wired remote controller display
E: 11. Serial communication error (Serial reverse transfer error) (Outdoor unit)	11
E: 11. Serial communication error (Serial forward transfer error) (Indoor unit)	11
E: 12. Wired remote controller communication error (Indoor unit)	12
E: 18. External communication error (Indoor unit)	18
E: 23. Combination error (Outdoor unit)	23
E: 26. Address setting error in wired remote controller (Indoor unit)	26
E: 29. Connected unit number error (Indoor unit)	29
E: 32. Indoor unit main PCB error (Indoor unit)	32
E: 33. Indoor unit motor electricity consumption detection error (Indoor unit)	33
E: 35. MANUAL AUTO button error (Indoor unit)	35
E: 39. Indoor unit power supply error for fan motor (Indoor unit)	39
E: 3A. Indoor unit communication circuit (wired remote controller) error	3A
E: 41. Room temperature sensor error (Indoor unit)	41
E: 42. Indoor unit heat exchanger sensor error (Indoor unit)	42
E: 51. Indoor unit fan motor error (Indoor unit)	51
E: 53. Drain pump error (Indoor unit)	53
E: 62. Outdoor unit main PCB error (Outdoor unit)	62
E: 63. Inverter error (Outdoor unit)	63
E: 64. PFC circuit error (Outdoor unit)	64
E: 65. Trip terminal L error (Outdoor unit)	65
E: 71. Discharge thermistor error (Outdoor unit)	71
E: 72. Compressor thermistor error (Outdoor unit)	72
E: 73. Heat exchanger (Middle/Outlet) temperature thermistor error (Outdoor unit)	73
E: 74. Outdoor temperature thermistor error (Outdoor unit)	74
E: 77. Heat sink thermistor error (Outdoor unit)	77
E: 84. Current sensor error (Outdoor unit)	84
E: 86. High pressure switch error (Outdoor unit)	86
E: 94. Trip detection (Outdoor unit)	94
E: 95. Compressor motor control error (Outdoor unit)	95
E: 97. Outdoor unit fan motor error (Outdoor unit)	97
E: 99. 4-way valve error (Outdoor unit)	99
E: A1. Discharge temperature error (Outdoor unit)	A1
E: A3. Compressor temperature error (Outdoor unit)	A3
E: A5. Low pressure error (Outdoor unit)	A5
E: AC. Heat sink temperature error (Outdoor unit)	AC

1-2. Error code table (Outdoor unit)

The operation status is determined by the lighting up and blinking of the LED lamp.
After check that ERROR LED lamp blinks, press the ENTER button once.

NOTE: For the positions of LED lamp and buttons, refer to "Functionsettings (for outdoor unit)" in Chapter 5. FIELD WORK.

Error contents	POWER/ MODE	ERROR	PUMP DOWN	LOW NOISE		PEAK CUT		
			L1	L2	L3	L4	L5	L6
E: 11. Serial communication error (Serial forward transfer error) (Indoor unit)	■ 2	●	■ 1	■ 1	○	○	●	●
E: 11. Serial communication error (Serial forward transfer error) (Indoor unit)	■ 2	●	■ 1	■ 1	○	●	○	○
E: 12. Wired remote controller communication error (Indoor unit)	■ 2	●	■ 5	■ 15	○	○	○	●
E: 18. External communication error (Indoor unit)	■ 2	●	■ 5	■ 15	○	○	○	●
E: 23. Combination error (Outdoor unit)	■ 2	●	■ 5	■ 15	○	○	○	●
E: 26. Address setting error in wired remote controller (Indoor unit)	■ 2	●	■ 5	■ 15	○	○	○	●
E: 29. Connected unit number error (Indoor unit)	■ 2	●	■ 5	■ 15	○	○	○	●
E: 32. Indoor unit main PCB error (Indoor unit)	■ 2	●	■ 5	■ 15	○	○	○	●
E: 33. Indoor unit motor electricity consumption detection error (Indoor unit)	■ 2	●	■ 5	■ 15	○	○	○	●
E: 39. Indoor unit power supply error for fan motor (Indoor unit)	■ 2	●	■ 5	■ 15	○	○	○	●
E: 3A. Indoor unit communication circuit (wired remote controller) error	■ 2	●	■ 5	■ 15	○	○	○	●
E: 41. Room temperature sensor error (Indoor unit)	■ 2	●	■ 5	■ 15	○	○	○	●
E: 42. Indoor unit heat exchanger sensor error (Indoor unit)	■ 2	●	■ 5	■ 15	○	○	○	●
E: 51. Indoor unit fan motor error (Indoor unit)	■ 2	●	■ 5	■ 15	○	○	○	●
E: 53. Drain pump error (Indoor unit)	■ 2	●	■ 5	■ 15	○	○	○	●
E: 62. Outdoor unit main PCB error (Outdoor unit)	■ 2	●	■ 6	■ 2	○	○	○	●
E: 63. Inverter error (Outdoor unit)	■ 2	●	■ 6	■ 3	○	○	○	●
E: 65. Trip terminal L error (Outdoor unit)	■ 2	●	■ 6	■ 5	○	○	●	●
E: 71. Discharge thermistor error (Outdoor unit)	■ 2	●	■ 7	■ 1	○	○	○	●
E: 72. Compressor thermistor error (Outdoor unit)	■ 2	●	■ 7	■ 2	○	○	○	●
E: 73. Heat exchanger (Middle/Outlet) temperature thermistor error (Outdoor unit)	■ 2	●	■ 7	■ 3	○	○	●	○
E: 74. Outdoor temperature thermistor error (Outdoor unit)	■ 2	●	■ 7	■ 4	○	○	○	●
E: 77. Heat sink thermistor error (Outdoor unit)	■ 2	●	■ 7	■ 7	○	○	○	●

Error contents	POWER/ MODE	ERROR	PUMP DOWN	LOW NOISE		PEAK CUT		
			L1	L2	L3	L4	L5	L6
E: 84. Current sensor error (Outdoor unit)	■ 2	●	■ 8	■ 4	○	○	○	●
E: 86. High pressure switch error (Outdoor unit)	■ 2	●	■ 8	■ 6	○	●	●	○
E: 94. Trip detection (Outdoor unit)	■ 2	●	■ 9	■ 4	○	○	○	●
E: 95. Compressor motor control error (Outdoor unit)	■ 2	●	■ 9	■ 5	○	○	○	●
E: 97. Outdoor unit fan motor error (Outdoor unit)	■ 2	●	■ 9	■ 7	○	○	●	●
E: 99. 4-way valve error (Outdoor unit)	■ 2	●	■ 9	■ 9	○	○	○	●
E: A1. Discharge temperature error (Outdoor unit)	■ 2	●	■ 10	■ 1	○	○	○	●
E: A3. Compressor temperature error (Outdoor unit)	■ 2	●	■ 10	■ 3	○	○	○	●
E: A5. Low pressure error (Outdoor unit)	■ 2	●	■ 10	■ 5	○	○	○	●
E: AC. Heat sink temperature error (Outdoor unit)	■ 2	●	■ 10	■ 12	○	○	●	●

● : Light on ○ : Light off ■ (n) : n Times blinking

2. Troubleshooting with error code

2-1. E: 11. Serial communication error (Serial reverse transfer error) (Outdoor unit)

Indicator	Wired remote controller	Error code	E: 11
Detective actuator	Outdoor unit	Main PCB	When the indoor unit cannot receive the serial signal from outdoor unit more than 2 minutes after power on, or the indoor unit cannot receive the serial signal more than 15 seconds during normal operation.
		Fan motor	
Forecast of cause			Connection failure
			External cause
			Main PCB failure
			Outdoor unit fan motor failure

Check point 1. Reset the power and operate

Does error indication show again?

→ If no, go to "Check point 1-2".



Check point 2. Check connection

Check any loose or removed connection line of indoor unit and outdoor unit.

Check connection condition is control unit. (If there is loose connector, open cable or mis-wiring.)

→ If there is an abnormal condition, correct it by referring to the installation manual or the "DESIGN & TECHNICAL MANUAL".



Check point 3. Check the voltage of power supply

Check the voltage of power supply

Check if AC 198 V (AC 220 V -10%) to AC 264 V (AC 240 V +10%) appears at outdoor unit terminal L — N.



Check point 4. Check serial signal (Reverse transfer signal)

Check serial signal (Reverse transfer signal)

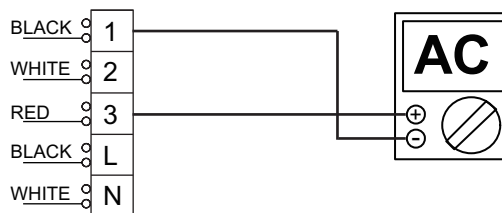

- Check if indicated value swings between AC 90 V and AC 270 V at the outdoor unit terminal 1—3.
- If it is abnormal, check the parts below.
 - Outdoor unit fan motor in "[Service parts information](#)" on page 03-52
- If outdoor fan motor is abnormal, replace outdoor unit fan motor and main PCB.
- If the checked parts are normal, replace the main PCB.



End

Check point 1-2. Check external cause such as noise

- Check the complete insulation of the grounding.
- Check if there is any equipment that causes harmonic wave near the power cable (Neon light bulb or any electronic equipment which causes harmonic wave).



End

2-2. E: 11. Serial communication error (Serial forward transfer error) (Indoor unit)

Indicator	Wired remote controller	Error code	E: 11
Detective actuator	Indoor unit	Main PCB	When the outdoor unit cannot receive the serial signal from indoor unit more than 10 seconds.
Forecast of cause			Connection failure
			External cause
			Main PCB failure

Check point 1. Reset the power and operate

Does error indication show again?

→ If no, go to "Check point 1-2".



Check point 2. Check connection

Check any loose or removed connection line of indoor unit and outdoor unit.

Check connection condition is control unit. (If there is loose connector, open cable or mis-wiring.)

→ If there is an abnormal condition, correct it by referring to the installation manual or the "DESIGN & TECHNICAL MANUAL".



Check point 3. Check the voltage of power supply

Check the voltage of power supply

Check if AC 198 V (AC 220 V -10%) to AC 264 V (AC 240 V +10%) appears at outdoor unit terminal L — N.

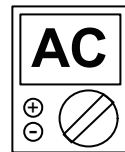

Check point 4. Check serial signal (Forward transfer signal)

Check serial signal (Forward transfer signal)

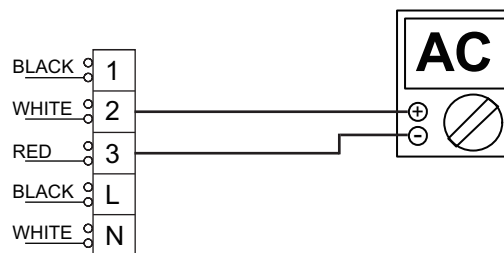

- Check if indicated value swings between AC 30 V and AC 130 V at outdoor unit terminal 2—3.
- If it is abnormal, replace main PCB.



End

Check point 1-2. Check external cause such as noise

- Check the complete insulation of the grounding.
- Check if there is any equipment that causes harmonic wave near the power cable (Neon light bulb or any electronic equipment which causes harmonic wave).



End

2-3. E: 12. Wired remote controller communication error (Indoor unit)

Indicator	Wired remote controller	Error code	E: 12
Detective actuator	Indoor unit	Main PCB	When the indoor unit cannot receive the signal from wired remote controller more than following time during normal operation. <ul style="list-style-type: none"> • 3-wire type: 1 minute • 2-wire type: 2.5 minutes
	Wired remote control		
Forecast of cause			Terminal connection abnormal
			Wired remote control failure
			Main PCB failure

Check point 1. Check the connection of terminal

After turning off the power, check & correct the followings.

- Check the connection of terminal between wired remote controller and indoor unit, and check if there is a disconnection of the cable.



Check Point : Check Wired remote controller and main PCB

Check voltage at CN14 of main PCB (terminal 1—3, terminal 1—2). (Power supply to the remote controller)

Upon correcting the removed connector or mis-wiring, reset the power.



- If it is DC 12 V, remote controller is failure. (Main PCB is normal)
 - Replace remote control
- If it is DC 0 V, main PCB is failure. (Check remote controller once again)
 - Replace main PCB



End

2-4. E: 18. External communication error (Indoor unit)

Indicator	Wired remote controller	Error code	E: 18
Detective actuator	Indoor unit	External communication error	After receiving a signal from the external input and output PCB, the same signal has not been received for 15 seconds.
Forecast of cause			Connection failure
			External input and output PCB failure
			Main PCB

Check point 1. Check the connection

- Check any loose or removed connection between the main PCB to the external input and output PCB.
-> If there is an abnormal condition, correct it by refer to the installation manual or the "DESIGN & TECHNICAL MANUAL".
- Check the connection condition on the external input and output PCB and the main PCB (If there is loose connector, open cable or mis-wiring.)



Check point 2. Replace the external input and output PCB

If check point 1 do not improve the symptom, change external input and output PCB



Check point 3. Replace main PCB

If check point 2 do not improve the symptom, change main PCB



End

2-5. E: 23. Combination error (Outdoor unit)

Indicator	Wired remote controller	Error code	E: 23
Detective actuator	Indoor unit		• When the outdoor unit type is multi type
Forecast of cause			Incorrect indoor unit is selected.

Check point 1. Check the type of indoor unit

- Check the type of the connected indoor unit.
-> If there is an abnormal condition, correct it by refer to the installation manual or the "DESIGN & TECHNICAL MANAL".



Check point 2. Replace main PCB

If check point 1 do not improve the symptom, replace main PCB of the outdoor unit.



End

2-6. E: 26. Address setting error in wired remote controller (Indoor unit)

Indicator	Wired remote controller	Error code	E: 26
Detective actuator	Wired remote controller (2-wire)	Indoor unit controller PCB	<ul style="list-style-type: none"> When the address number set by auto setting and manual setting are mixed in one remote controller group When the duplicated address number exists in one remote controller group
Forecast of cause			Wrong wiring of remote controller group
			Wrong remote controller address setting
			Indoor unit main PCB failure
			Remote controller failure

Check point 1. Wire installation

- Check the wire connection in the remote controller group (For installation method, refer to installation manual)
-> If there is an abnormal condition, correct it by refer to the installation manual or the "DESIGN & TECHNICAL MANUAL".



Check point 2. Wrong remote controller group setting

- The given address number by auto setting (00) and the manual set number (except 00) are not existing in one remote controller group.
- The remote controller address setting by UI is not existing same address.
- The duplicate address number is not existing in one remote controller group.



Check point 3. Check indoor unit main PCB

- Check if main PCB is damaged.
- Change main PCB and check the error after setting remote controller address.



End

2-7. E: 29. Connected unit number error (Indoor unit)

Indicator	Wired remote controller	Error code	E: 29
Detective actuator	Wired remote controller (2-wire)	When the number of the connected indoor unit exceeds the limitation.	
	Indoor unit main PCB		
Forecast of cause		Wrong wiring of indoor unit or remote controller	
		Number of indoor unit or remote controller in remote controller group	
		Indoor unit main PCB failure	

Check point 1. Wire installation

- Wrong number of connected indoor unit
-> If there is an abnormal condition, correct it by refer to the installation manual or the "DESIGN & TECHNICAL MANUAL".



Check point 2. Check indoor unit main PCB

- Check if main PCB is damaged.
- Change main PCB and check the error after setting remote controller address.



End

2-8. E: 32. Indoor unit main PCB error (Indoor unit)

Indicator	Wired remote controller	Error code	E: 32
Detective actuator	Indoor unit	main PCB	When power is on and there is some below case. 1. When model information of EEPROM is incorrect. 2. When the access to EEPROM failed.
Forecast of cause			External cause
			Defective connection of electric components
			Main PCB failure

Check point 1. Reset power supply and operate

Does error indication show again?

→ If no, go to "Check point 1-2".



Check point 2. Check Indoor unit electric components

- Check all connectors. (loose connector or incorrect wiring)
- Check any shortage or corrosion on PCB.



Check point 3. Replace main PCB

Change main PCB.



End

Check point 1-2. Check external cause such as noise

- Check if the ground connection is proper.
- Check if there is any equipment that causes harmonic wave near the power cable (Neon light bulb or any electronic equipment which causes harmonic wave).



End

NOTE: EEPROM

EEPROM (Electrically Erasable and Programmable Read Only Memory) is a non-volatile memory which keeps memorized information even if the power is turned off. It can change the contents electronically. To change the contents, it uses higher voltage than normal, and it cannot change a partial contents. (Rewriting shall be done upon erasing the all contents.) There is a limit in a number of rewriting.

2-9. E: 33. Indoor unit motor electricity consumption detection error (Indoor unit)

Indicator	Wired remote controller	Error code	E: 33
Detective actuator	Indoor unit motor electricity consumption detection		When the voltage value or the current value of the motor go beyond the limits
Forecast of cause			Fan motor failure
			Main PCB failure

Check point 1. Check the rotation of fan

Rotate the fan by hand when the operation is off. (Check if fan is caught, drop off or locked motor)
→ If fan or bearing is abnormal, replace it.



Check point 2. Check ambient temperature around the motor

Check excessively high temperature around the motor. (If there is any surrounding equipment that causes heat.)
→ Upon the temperature coming down, restart operation.



Check point 3. Check indoor unit fan motor

Check indoor unit fan motor. (Refer to indoor unit fan motor in "[Service parts information](#)" on page 03-52.)
→ If indoor unit fan motor is abnormal, replace it.



Check point 4. Replace main PCB

If check point 1-3 does not improve the symptom, change main PCB.



End

2-10. E: 35. MANUAL AUTO button error (Indoor unit)

Indicator	Wired remote controller	Error code	E: 35
Detective actuator	Indoor unit controller PCB		When the MANUAL AUTO button becomes on for consecutive 60 or more seconds.
	Indicator PCB		
	Manual auto switch		
Forecast of cause			MANUAL AUTO button failure
			Controller PCB and indicator PCB failure

Check point 1. Check the MANUAL AUTO button

- Check if MANUAL AUTO button is kept pressed.
- Check On/Off switching operation by using a meter.



If MANUAL AUTO button is disabled (on/off switching), replace it.



Check point 2. Replace main PCB and indicator PCB

If Check Point 1 does not improve the symptom, change main PCB and indicator PCB.



End

2-11. E: 39. Indoor unit power supply error for fan motor (Indoor unit)

Indicator	Wired remote controller	Error code	E: 39
Detective actuator	Indoor unit main PCB		<ul style="list-style-type: none"> When a momentary power cut off When do not start fan motor
Forecast of cause			External cause
			Connector connection failure
			Main PCB failure

Check point 1. Check external cause at indoor and outdoor (Voltage drop or Noise)

- Instant drop: Check if there is a large load electric apparatus in the same circuit.
- Momentary power failure: Check if there is a defective contact or leak current in the power supply circuit.
- Noise: Check if there is any equipment causing harmonic wave near electric line. (Neon bulb or electric equipment that may cause harmonic wave)
Check the complete insulation of grounding.



Check point 2. Check connection of Connector

- Check if connector is removed.
- Check erroneous connection.
- Check if cable is open.

→ Upon correcting the removed connector or mis-wiring, reset the power.



Check point 3. Replace main PCB

If check point 1 to 2 do not improve the symptom, change main PCB.



End

2-12. E: 3A. Indoor unit communication circuit (wired remote controller) error

Indicator	Wired remote controller	Error code	E: 3A
Detective actuator	Wired remote controller (2-wire)	Indoor unit controller PCB circuit	Detect the communication error of microcomputer and communication PCB.
	Indoor unit controller PCB circuit		
Forecast of cause			Communication PCB defective
			Indoor unit main PCB defective

Check point 1. Check the connection of terminal

- After turning off the power supply, check and correct the followings
Indoor unit - Check the connection the communication PCB and the main PCB



Check Point 2 : Replace the communication PCB

If the Check point 1 is ok, replace the communication PCB



Check Point 3 : Replace the main PCB

If condition is doesn't change, replace the main PCB



End

2-13. E: 41. Room temperature sensor error (Indoor unit)

Indicator	Wired remote controller	Error code	E: 41
Detective actuator	Indoor unit main PCB	Room temperature thermistor is open or short is detected always.	
	Room temperature thermistor		
Forecast of cause			Connector failure
			Thermistor failure
			Main PCB failure

Check point 1. Check connection of connector

- Check if connector is loose or removed.
- Check erroneous connection.
- Check if thermistor cable is open

-> Reset power when reinstalling due to removed connector or incorrect wiring.



Check point 2. Remove connector and check thermistor resistance value

- For the room thermistor resistance value, refer to "[Thermistor resistance values](#)" on page 03-61.
- If thermistor is either open or shorted, replace it and reset the power.

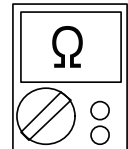

Check point 3. Check voltage of main PCB

Make sure circuit diagram of each indoor unit and check terminal voltage at thermistor (DC 5.0 V).

NOTE: For details of thermistor connector, refer to "Wiring diagrams" in Chapter 2. TECHNICAL DATA AND PARTS LIST.

If the voltage does not appear, replace main PCB.

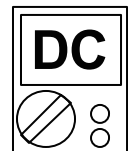

End

2-14. E: 42. Indoor unit heat exchanger sensor error (Indoor unit)

Indicator	Wired remote controller	Error code	E: 42
Detective actuator	Indoor unit main PCB	Heat exchanger temperature thermistor	When heat exchanger temperature thermistor open or short circuit is detected.
Forecast of cause			Connector connection failure
			Thermistor failure
			Main PCB failure

Check point 1. Check connection of connector

- Check if connector is loose or removed.
- Check erroneous connection.
- Check if thermistor cable is open

-> Reset power when reinstalling due to removed connector or incorrect wiring.



Check point 2. Remove connector and check thermistor resistance value

- For the heat exchanger thermistor resistance value, refer to "[Thermistor resistance values](#)" on page 03-61.
- If thermistor is either open or shorted, replace it and reset the power.

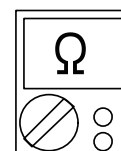

Check point 3. Check voltage of main PCB

Make sure circuit diagram of each indoor unit and check terminal voltage at thermistor (DC 5.0 V).

NOTE: For details of thermistor connector, refer to "Wiring diagrams" in Chapter 2. TECHNICAL DATA AND PARTS LIST.

If the voltage does not appear, replace main PCB.



End

2-15. E: 51. Indoor unit fan motor error (Indoor unit)

Indicator	Wired remote controller	Error code	E: 51
Detective actuator	Indoor unit	main PCB	When the condition that actual frequency of indoor fan is below 1/3 of target frequency is continued more than 56 seconds.
		Fan motor	
Forecast of cause			Fan rotation failure
			Fan motor winding open
			Motor protection by surrounding temperature rise
			Control PCB failure
			Indoor unit fan motor failure

Check point 1. Check rotation of fan

Rotate the fan by hand when operation is off. (Check if fan is caught, dropped off or locked motor)
→ If fan or bearing is abnormal, replace it.



Check point 2. Check ambient temperature around motor

Check excessively high temperature around the motor. (If there is any surrounding equipment that causes heat)
→ Upon the temperature coming down, restart operation.



Check point 3. Check indoor unit fan motor

Check Indoor unit fan motor. (Refer to indoor unit fan motor in "[Service parts information](#)" on page 03-52.)
→ If Indoor unit fan motor is abnormal, replace Indoor unit fan motor.



Check point 4. Replace main PCB

If Check Point 1 to 3 do not improve the symptom, replace main PCB.



End

2-16. E: 53. Drain pump error (Indoor unit)

Indicator	Wired remote controller	Error code	E: 53
Detective actuator	Indoor unit main PCB	Float switch	When Float switch is ON for more than 3 minutes.
Forecast of cause			Float switch failure
			Shorted connector/wire failure
			Main PCB failure
			Drain pump failure
			Hose clogging

Check point 1. Check float switch

- Check operation of float switch. (any blocking by dust, etc.)
- Remove float switch and check ON/OFF switching operation by using a meter.

-> If float switch is abnormal, replace it.

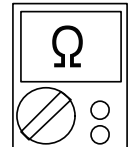

Check point 2. Check connector and wire

Check loose contact of CN9 and shorted wire (pinched wire).
-> Replace float switch if the wire is abnormal



Check point 3. Check drain hose

Check drain hose.
-> If there is hose clogging. Please clear the clog.



Check point 4. Check voltage of power supply and drain pump

Check drain pump
-> If drain pump is not run on the working condition, check the voltage of the CN71 on the main PCB.

Measurement result

- 12V: Replace the drain pump
- Other than 12V: Replace the main PCB

NOTE: For details of thermistor connector, refer to "Wiring diagrams" in Chapter 2. TECHNICAL DATA AND PARTS LIST.



End

2-17. E: 62. Outdoor unit main PCB error (Outdoor unit)

Indicator	Wired remote controller	Error code	E: 62
Detective actuator	Outdoor unit	Main PCB	Access to EEPROM failed due to some cause after outdoor unit started.
Forecast of cause			External cause (Noise, temporary open, voltage drop) Main PCB failure

Check point 1. Reset power supply and operate

Does error indication show again?

If no, go to "Check point 1-2".



Check point 2. Replace main PCB

Change main PCB.



End

Check point 1-2. Check external cause

- Check if temporary voltage drop was not generated.
- Check if momentary open was not generated.
- Check if ground is connection correctly or there are no related cables near the power line.



End

2-18. E: 63. Inverter error (Outdoor unit)

Indicator	Wired remote controller	Error code	E: 63
Detective actuator	Outdoor unit	Inverter PCB	Error information received from inverter PCB
Forecast of cause			External cause
			Power supply to inverter PCB wiring disconnection or open
			Inverter PCB failure

Check point 1. Turn the power on again?

Error displayed again?

If no, go to "Check point 1-2".



Check point 2. Check the wiring (power supply to inverter PCB)

- Connector and wiring connection state check
- Cable open check



Check point 3. Replace inverter PCB

Replace inverter PCB



End

Check point 1-2. Check external cause

- Check if temporary voltage drop was not generated.
- Check if momentary open was not generated.
- Check if ground is connection correctly or there are no related cables near the power line.



End

2-19. E: 64. PFC circuit error (Outdoor unit)

Indicator	Wired remote controller	Error code	E: 64
Detective actuator	Outdoor unit	Main PCB	<ul style="list-style-type: none"> When inverter input DC voltage is higher than 420 V for over 3 seconds, the compressor stops. If the same operation is repeated 5 times, the compressor stops permanently.
Forecast of cause			External cause
			Connector connection failure
			Main PCB failure

Check point 1. Check external cause at indoor and outdoor (Voltage drop or Noise)

- Instant drop: Check if there is a large load electric apparatus in the same circuit.
- Momentary power failure: Check if there is a defective contact or leak current in the power supply circuit.
- Noise: Check if there is any equipment causing harmonic wave near electric line. (Neon bulb or electric equipment that may cause harmonic wave)
Check the complete insulation of grounding.



Check point 2. Check connection of Connector

- Check if connector is removed.
- Check erroneous connection.
- Check if cable is open.

→ Upon correcting the removed connector or mis-wiring, reset the power.



Check point 3. Replace main PCB

If check point 1 to 2 do not improve the symptom, change main PCB.



End

2-20. E: 65. Trip terminal L error (Outdoor unit)

Indicator	Wired remote controller	Error code	E: 65
Detective actuator	Outdoor unit	Main PCB	When the signal from FO terminal of IPM is "L" (0 V) during the compressor stopping.
Forecast of cause			Main PCB failure

Check point 1. Check main PCB

Replace the outdoor unit main PCB.



End

2-21. E: 71. Discharge thermistor error (Outdoor unit)

Indicator	Wired remote controller	Error code	E: 71
Detective actuator	Outdoor unit main PCB	When discharge pipe temperature thermistor open or short circuit is detected at power on or while running the compressor	
	Discharge pipe temperature thermistor		
Forecast of cause			Connector failure
			Thermistor failure
			Main PCB failure

Check point 1. Check connection of connector

- Check if connector is loose or removed.
- Check erroneous connection.
- Check if thermistor cable is open

→ Reset power when reinstalling due to removed connector or incorrect wiring.



Check point 2. Remove connector and check thermistor resistance value

- For the discharge temperature thermistor resistance value, refer to "[Thermistor resistance values](#)" on page 03-61.
- If thermistor is either open or shorted, replace it and reset the power.

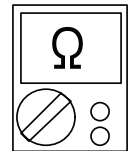

Check point 3. Check voltage of main PCB

Make sure circuit diagram of outdoor unit and check terminal voltage at thermistor (DC 5.0 V).

NOTE: For details of thermistor connector, refer to "Wiring diagrams" in Chapter 2. TECHNICAL DATA AND PARTS LIST.

If the voltage does not appear, replace main PCB.

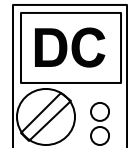

End

2-22. E: 72. Compressor thermistor error (Outdoor unit)

Indicator	Wired remote controller	Error code	E: 72
Detective actuator	Outdoor unit main PCB	When compressor temperature thermistor open or short circuit is detected at power on or while running the compressor	
	Compressor temperature thermistor		
Forecast of cause			Connector failure
			Thermistor failure
			Main PCB failure

Check point 1. Check connection of connector

- Check if connector is loose or removed.
- Check erroneous connection.
- Check if thermistor cable is open

→ Reset power when reinstalling due to removed connector or incorrect wiring.



Check point 2. Remove connector and check thermistor resistance value

- For the compressor thermistor resistance value, refer to "[Thermistor resistance values](#)" on page 03-61.
- If thermistor is either open or shorted, replace it and reset the power.

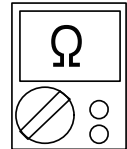

Check point 3. Check voltage of main PCB

Make sure circuit diagram of outdoor unit and check terminal voltage at thermistor (DC 5.0 V).

NOTE: For details of thermistor connector, refer to "Wiring diagrams" in Chapter 2. TECHNICAL DATA AND PARTS LIST.

If the voltage does not appear, replace main PCB.

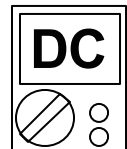

End

2-23. E: 73. Heat exchanger (Middle/Outlet) temperature thermistor error (Outdoor unit)

Indicator	Wired remote controller	Error code	E: 73
Detective actuator	Heat exchanger liquid temperature thermistor	Heat exchanger middle temperature thermistor	• Heat exchanger liquid temperature thermistor short or open detected
	Heat exchanger middle temperature thermistor		• Heat exchanger middle temperature thermistor short or open detected
Forecast of cause			Connector failure
			Thermistor failure
			Main PCB failure

Check Point 1 : Check the connector connection and cable open

- Connector connection state check
- Cable open check



Check Point 2 : Check the thermistor

- For the outdoor unit heat exchanger thermistor resistance value, refer to "[Thermistor resistance values](#)" on page 03-61.
- If thermistor is either open or shorted, replace it and reset the power.

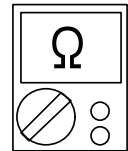

Check point 3. Check voltage of main PCB

Make sure circuit diagram of outdoor unit and check terminal voltage at thermistor (DC 5.0 V).

NOTE: For details of thermistor connector, refer to "Wiring diagrams" in Chapter 2. TECHNICAL DATA AND PARTS LIST.

If the voltage does not appear, replace main PCB.



End

2-24. E: 74. Outdoor temperature thermistor error (Outdoor unit)

Indicator	Wired remote controller	Error code	E: 74
Detective actuator	Outdoor unit main PCB	When outdoor temperature thermistor open or short circuit is detected at power on or while running the compressor	
	Outdoor temperature thermistor		
Forecast of cause			Connector failure
			Thermistor failure
			Main PCB failure

Check point 1. Check connection of connector

- Check if connector is loose or removed.
- Check erroneous connection.
- Check if thermistor cable is open

-> Reset power when reinstalling due to removed connector or incorrect wiring.



Check point 2. Remove connector and check thermistor resistance value

- For the outdoor temperature thermistor resistance value, refer to "[Thermistor resistance values](#)" on page 03-61.
- If thermistor is either open or shorted, replace it and reset the power.

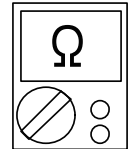

Check point 3. Check voltage of main PCB

Make sure circuit diagram of outdoor unit and check terminal voltage at thermistor (DC 5.0 V).

NOTE: For details of thermistor connector, refer to "Wiring diagrams" in Chapter 2. TECHNICAL DATA AND PARTS LIST.

If the voltage does not appear, replace main PCB.

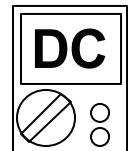

End

2-25. E: 77. Heat sink thermistor error (Outdoor unit)

Indicator	Wired remote controller	Error code	E: 77
Detective actuator	Heat sink temperature thermistor	Heat sink temperature thermistor short or open detected	
Forecast of cause			Connector failure
			Thermistor failure
			Inverter PCB failure

Check point 1. Check connection of connector

- Check if connector is loose or removed.
- Check erroneous connection.
- Check if thermistor cable is open

-> Reset power when reinstalling due to removed connector or incorrect wiring.



Check point 2. Remove connector and check thermistor resistance value

- For the Heat sink thermistor resistance value, refer to "[Thermistor resistance values](#)" on page 03-61.
- If thermistor is either open or shorted, replace it and reset the power.

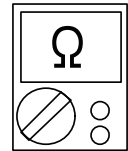

Check point 3. Check voltage of inverter PCB

Make sure circuit diagram of outdoor unit and check terminal voltage at thermistor (DC 5.0 V).

NOTE: For details of thermistor connector, refer to "Wiringdiagrams" in Chapter 2. TECHNICAL DATA AND PARTS LIST.

If the voltage does not appear, replace inverter PCB.

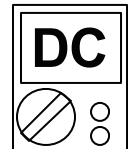

End

2-26. E: 84. Current sensor error (Outdoor unit)

Indicator	Wired remote controller	Error code	E: 84
Detective actuator	Outdoor unit	main PCB	When input current sensor has detected 0 A, while inverter compressor is operating at higher than 56 rps, after 1 minute upon starting the compressor. (Except during the defrost operation)
Forecast of cause			Defective connection of electric components
			External cause
			Main PCB failure

Check point 1. Reset power supply and operate

Does error indication show again?

If no, go to "Check point 1-2".



Check point 2. Check connections of outdoor unit electrical components

- Check if the terminal connection is loose.
- Check if connector is removed.
- Check erroneous connection.
- Check if cable is open.

Upon correcting the removed connector or miswiring, reset the power.



Check point 3. Replace main PCB

If Check point 1, 2 do not improve the symptom, change main PCB.



End

Check point 1-2. Check external cause at Indoor and Outdoor (Voltage drop or Noise)

- Instant drop: Check if there is a large load electric apparatus in the same circuit.
- Momentary power failure: Check if there is a defective contact or leak current in the power supply circuit.
- Noise: Check if there is any equipment causing harmonic wave near electric line. (Neon bulb or electric equipment that may cause harmonic wave)
Check the complete insulation of grounding.



End

2-27. E: 86. High pressure switch error (Outdoor unit)

Indicator	Wired remote controller	Error code	E: 86
Detective actuator	Outdoor unit main PCB	When pressure switch open is detected in 10 seconds after the power is turned on.	
	High pressure switch		
Forecast of cause	High pressure switch connector disconnection or open		
	High pressure switch characteristics failure		
	Main PCB failure		

Check point 1. Check the high pressure switch connection state

- Check connector and wiring connection state.
- Check if cable is open

-> Reset power when reinstalling due to removed connector or incorrect wiring.



Check point 2. Check the high pressure switch characteristics

- Check switch characteristics.
For the characteristics of the high pressure switch, refer to below.



Check point 3. Replace main PCB

Change main PCB and check operation again.



End

- Type of contact

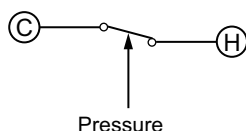

- Characteristics of pressure switch

Pressure switch 1	
Contact: Short → Open	4.2 ±0.1 MPa
Contact: Open → Short	3.2 ±0.15 MPa

36/45/54 model: P770

2-28. E: 94. Trip detection (Outdoor unit)

Indicator	Wired remote controller	Error code	E: 94
-----------	-------------------------	------------	-------

Check point 1. Check the outdoor unit fan operation, heat-exchanger, ambient temperature

- No obstructions in air passages?
- Heat exchange fins clogged
- Outdoor unit fan motor check
- Ambient temperature not raised by the effect of other heat sources?
- Discharged air not sucked in?



Check point . Replace inverter PCB

If Check point do not improve the symptom, change inverter PCB.



Check point . Replace main PCB

If Check point do not improve the symptom, change main PCB.



Check point . Replace compressor

If Check point do not improve the symptom, change compressor.



End

2-29. E: 95. Compressor motor control error (Outdoor unit)

Indicator	Wired remote controller	Error code	E: 95
-----------	-------------------------	------------	-------

Check point 1. Check Noise from Compressor

Turn on Power and check operation noise.
→ If an abnormal noise show, replace compressor.



Check point 2. Check connection of around the compressor components

For compressor terminal, main PCB

- Check if connector is removed.
- Check erroneous connection.
- Check if cable is open. (Refer to inverter compressor in "[Service parts information](#)" on page 03-52.)

→ Upon correcting the removed connector or mis-wiring, reset the power.



Check point . Replace main PCB

If Check point do not improve the symptom, change main PCB.



Check point . Replace compressor

If Check point do not improve the symptom, change compressor.



End

2-30. E: 97. Outdoor unit fan motor error (Outdoor unit)

Indicator	Wired remote controller	Error code	E: 97
Detective actuator	Outdoor unit	Main PCB	<ol style="list-style-type: none"> When outdoor fan rotation speed is less than 100 rpm in 20 seconds after fan motor starts, fan motor stops. After fan motor restarts, if the same operation within 60 seconds is repeated 3 times in a row, compressor and fan motor stops. If 1. and 2. repeats 5 times in a row, compressor and fan motor stops permanently.
		Fan motor	
Forecast of cause			Fan rotation failure
			Motor protection by surrounding temperature rise
			Main PCB failure
			Outdoor unit fan motor

Check point 1. Check rotation of fan

Rotate the fan by hand when operation is off. (Check if fan is caught, dropped off or locked motor)
→ If fan or bearing is abnormal, replace it.



Check point 2. Check ambient temperature around motor

Check excessively high temperature around the motor. (If there is any surrounding equipment that causes heat)
→ Upon the temperature coming down, restart operation.



Check point 3. Check outdoor unit fan motor

Check outdoor unit fan motor. (Refer to outdoor unit fan motor in "[Service parts information](#)" on page 03-52.)
→ If outdoor unit fan motor is abnormal, replace outdoor unit fan motor and main PCB.



Check point 4. Check output voltage of main PCB

Check outdoor unit circuit diagram and the voltage. (Measure at main PCB side connector)

NOTE: For details of wiring diagram, refer to "Wiring diagrams" in Chapter 2. TECHNICAL DATA AND PARTS LIST.



Read wire	DC voltage
Red—Black	280 V (AC 220 V -10%) to 373 V (AC 240 V +10%)
White—Black	15 ± 1.5 V

-> If the voltage is not correct, replace Main PCB.



End

2-31. E: 99. 4-way valve error (Outdoor unit)

Indicator	Wired remote controller	Error code	E: 99
Detective actuator	Indoor unit	main PCB	When the indoor heat exchanger temperature is compared with the room temperature, and either following condition is detected continuously two times, the compressor stops. Indoor heat exchanger temp. - Room temp. > 10 °C (Cooling or Dry operation) Indoor heat exchanger temp. - Room temp. < -10 °C (Heating operation) If the same operation is repeated 5 times, the compressor stops permanently.
	Heat exchanger temperature thermistor		
	Room temperature thermistor		
	4-way valve		
Forecast of cause			Air filter clogged
			Connector connection failure
			Thermistor failure
			Coil failure
			4-way valve failure
		Main PCB failure	

Check point 1. Check air filter condition

Check air filter dirty.

→ If the air filter dirty, clean up the air filter.



Check point 2. Check connection of connector

- Check if connector is removed.
- Check erroneous connection.
- Check if thermistor cable is open.

→ Upon correcting the removed connector or mis-wiring, reset the power.



Check point 3. Check each thermistor

- Isn't it fallen off the holder?
- Is there a cable pinched?

Check characteristics of room thermistor and indoor unit heat exchanger thermistor.

For the thermistor resistance value, refer to "[Thermistor resistance values](#)" on page 03-61.

→ If defective, replace the thermistor.



Check point 4. Check the solenoid coil and 4-way valve

NOTE: Refer solenoid coil and 4-way valve in "[Service parts information](#)" on page 03-52.

- **Solenoid coil**
Remove P60 from PCB and check the resistance value of coil. Resistance value is 1.97kΩ.
→ If it is open or abnormal resistance value, replace solenoid coil.
- **4-way valve**
Check each piping temperature, and the location of the valve by the temperature difference.
If the value location is not proper, replace 4-way valve.

**Check point 5. Replace main PCB**

If Check Point 1 to 4 do not improve the symptom, replace main PCB.



End

2-32. E: A1. Discharge temperature error (Outdoor unit)

Indicator	Wired remote controller	Error code	E: A1
Detective actuator	Outdoor unit main PCB		Protection stop by discharge temperature ≥ 110 °C during compressor operation generated 2 times within 24 hours.
	Discharge temperature thermistor		
Forecast of cause			3-way valve not opened
			EEV defective, strainer clogged
			Outdoor unit operation failure, foreign matter on heat exchanger
			Discharge temperature thermistor failure
			Insufficient refrigerant
			Main PCB failure

Check point 1. Check if 3-way valve is open

If the 3-way valve is closed, open the 3-way valve and check operation.

NOTE: For cooling operation, check gas side of the 3-way valve.
For heating operation, check liquid side of the 3-way valve.



Check point 2. Check the electronic expansion valve (EEV) and strainer

- Check if EEV open.
Refer to outdoor unit Electronic Expansion Valve (EEV) in "[Service parts information](#)" on page 03-52.
- Check the strainer clogging.



Check point 3. Check the outdoor unit fan and heat exchanger

- Check for foreign object at heat exchanger
- Check if fan can be rotated by hand.
- Check the motor. (Refer to outdoor unit fan motor in "[Service parts information](#)" on page 03-52.)



Check point 4. Check the discharge thermistor

The discharge temperature thermistor characteristics check. (Check by disconnecting thermistor from PCB.)

NOTE: For the characteristics of the thermistor, refer to "[Thermistor resistance values](#)" on page 03-61.



Check point 5. Check the refrigerant amount

Check the refrigerant leakage.



Check point 6. Replace main PCB

If check point 1 to 5 do not improve the symptom, replace the main PCB.



End

2-33. E: A3. Compressor temperature error (Outdoor unit)

Indicator	Wired remote controller	Error code	E: A3
Detective actuator	Outdoor unit main PCB		Protection stop by compressor temperature ≥ 108 °C during compressor operation generated 2 times within 24 hours.
	Compressor temperature thermistor		
Forecast of cause			3-way valve not opened
			EEV defective, strainer clogged
			Outdoor unit operation failure, foreign matter on heat exchanger
			Compressor temperature thermistor failure
			Insufficient refrigerant
			Main PCB failure

Check point 1. Check if 3-way valve is open

If the 3-way valve is closed, open the 3-way valve and check operation.

NOTE: For cooling operation, check gas side of the 3-way valve.
For heating operation, check liquid side of the 3-way valve.



Check point 2. Check the electronic expansion valve (EEV) and strainer

- Check if EEV open.
Refer to outdoor unit Electronic Expansion Valve (EEV) in "[Service parts information](#)" on page 03-52.
- Check the strainer clogging.



Check point 3. Check the outdoor unit fan and heat exchanger

- Check for foreign object at heat exchanger
- Check if fan can be rotated by hand.
- Check the motor. (Refer to outdoor unit fan motor in "[Service parts information](#)" on page 03-52.)



Check point 4. Check the compressor thermistor

The compressor temperature thermistor characteristics check. (Check by disconnecting thermistor from PCB.)

NOTE: For the characteristics of the thermistor, refer to "[Thermistor resistance values](#)" on page 03-61.



Check point 5. Check the refrigerant amount

Check the refrigerant leakage.



Check point 6. Replace main PCB

If check point 1 to 5 do not improve the symptom, replace the main PCB.



End

2-34. E: A5. Low pressure error (Outdoor unit)

Indicator	Wired remote controller	Error code	E: A5
Detective actuator	Outdoor unit main PCB		Protection stop by suction pressure ≥ 0.02 MPaG continued 5 minutes repeats 5 times within 24 hours.
	Suction pressure sensor		
Forecast of cause			3-way valve not opened
			Outdoor unit ambient temperature too low
			Outdoor unit operation failure, foreign matter on heat exchanger
			EEV defective, strainer clogged
			Solenoid valve defective
			Low pressure sensor characteristics defective
			Insufficient refrigerant
			Main PCB failure

Check point 1. Check if 3-way valve is open

If the 3-way valve is closed, open the 3-way valve and check operation.

NOTE: For cooling operation, check gas side of the 3-way valve.

For heating operation, check liquid side of the 3-way valve.



Check point 2. Check the outdoor unit ambient temperature (Only when heating operation)

Outdoor unit ambient temperature lower than operating range?



Check point 3. Check the outdoor unit fan and heat exchanger (Only when heating operation)

- No foreign object in air passage?
- Heat exchanger fins clogged?
- Fan rotates?
- Check the motor. (Refer to outdoor unit fan motor in "[Service parts information](#)" on page 03-52.)



Check point 4. Check the electronic expansion valve (EEV) and strainer

- Check if EEV open.
Refer to outdoor unit Electronic Expansion Valve (EEV) in "[Service parts information](#)" on page 03-52.
- Check the strainer clogging.



Check point 5. Check the suction pressure sensor

Check the suction pressure sensor characteristics.

NOTE: For the characteristics of the thermistor, refer to suction pressure sensor in "[Service parts information](#)" on page 03-52.



Check point 6. Check the refrigerant amount

Check the refrigerant leakage.



Check point 7. Replace main PCB

If check point 1 to 6 do not improve the symptom, replace the main PCB.



End

2-35. E: AC. Heat sink temperature error (Outdoor unit)

Indicator	Wired remote controller	Error code	E: AC
Detective actuator	Outdoor unit inverter PCB		Protection stop by heat sink temperature ≥ 80 °C during heat sink operation generated 2 times within 24 hours.
	Heat sink temperature thermistor		
Forecast of cause			Foreign matter on heat sink, heat sink dirty
			Foreign matter on heat exchanger, excessive ambient temperature rise
			Heat sink temp. thermistor defective

Check point 1. Check the heat sink state

Heat sink foreign matter, soiling check



Check point 2. Check the foreign matter and ambient temperature of heat exchanger

- Heat exchange foreign matter check
- Ambient temperature not raised by effect of other heat sources?
- Discharged air not sucked in?



Check point 3. Check the heat sink temperature thermistor

The heat sink temperature thermistor characteristics check. (Check by disconnecting thermistor from PCB.)

NOTE: For the characteristics of the thermistor, refer to "[Thermistor resistance values](#)" on page 03-61.



Check point 4. Replace inverter PCB

Replace inverter PCB



End

3. Troubleshooting without error code

3-1. Indoor unit—No power

Forecast of cause	Power supply failure
	External cause
	Electrical components defective

Check point 1. Check installation condition

- Isn't the breaker down?
- Check loose or removed connection cable.

-> If abnormal condition is found, correct it by referring to the installation manual or the "DESIGN & TECHNICAL MANUAL".



Check point 2. Check external cause at indoor and outdoor (voltage drop or noise)

- Instant drop: Check if there is a large load electric apparatus in the same circuit.
- Momentary power failure: Check if there is a defective contact or leak current in the power supply circuit.
- Noise: Check if there is any equipment causing harmonic wave near electric line. (Neon bulb or electric equipment that may cause harmonic wave)
Check the complete insulation of grounding.



Check point 3. Check electrical components

Check the voltage of power supply.

Check if AC 198 to 264 V appears at outdoor unit terminal L—N.

-> If no, go to "[Check point 1](#)" and "[Check point 2](#)".



- Check fuse in filter PCB.
If fuse is open, check if the wiring between terminal and filter PCB is loose, and replace fuse.
- Check varistor in filter PCB.
If varistor is defective, there is a possibility of an abnormal power supply.
Check the correct power supply and replace varistor.
Upon checking the normal power supply, replace varistor.



End

3-2. Outdoor unit—No power

Forecast of cause	Power supply failure
	External cause
	Electrical components defective

Check point 1. Check installation condition

- Is the circuit breaker on or off?
- Check loose or removed connection cable.

→ If abnormal condition is found, correct it by referring to the installation manual or the "DESIGN & TECHNICAL MANUAL".



Check point 2. Check external cause at indoor and outdoor (voltage drop or noise)

- Instant drop: Check if there is a large load electric apparatus in the same circuit.
- Momentary power failure: Check if there is a defective contact or leak current in the power supply circuit.
- Noise: Check if there is any equipment causing harmonic wave near electric line. (Neon bulb or electric equipment that may cause harmonic wave)
Check the complete insulation of grounding.



Check point 3. Check electrical components

Check the voltage of power supply.

Check if AC 198 to 264 V appears at outdoor unit terminal L — N

→ If no, go to "[Check point 1](#)" and "[Check point 2](#)".

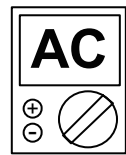

- Check fuse in main PCB.
If fuse is open, check if the wiring between terminal and main PCB is loose, and replace fuse.



Check point 4. Replace main PCB

If check point 1 to 3 do not improve the symptom, change main PCB.



End

3-3. No operation (Power is on)

Forecast of cause	Setting/ Connection failure
	External cause
	Electrical components defective

Check point 1. Check indoor and outdoor installation condition

-> If there is some abnormal condition, correct it by referring to the installation manual and "DESIGN & TECHNICAL MANUAL".



Turn off the power and check correct followings.

- Is there loose or removed communication line of indoor unit and outdoor unit?



Check point 2. Check external cause at indoor and outdoor (Voltage drop or Noise)

- Instant drop: Check if there is a large load electric apparatus in the same circuit.
- Momentary power failure: Check if there is a defective contact or leak current in the power supply circuit.
- Noise: Check if there is any equipment causing harmonic wave near electric line. (Neon bulb or electric equipment that may cause harmonic wave)
Check the complete insulation of grounding.



Check point . Replace main PCB

If check point 1 to do not improve the symptom, change main PCB.



End

3-4. No cooling/No heating

Forecast of cause	Indoor unit error
	Outdoor unit error
	Effect by surrounding environment
	Connection pipe/Connection wire failure
	Refrigeration cycle failure

Check point 1. Check Indoor unit

- Does Indoor unit fan run in the HIGH mode?
- Is air filter dirty?
- Is heat exchanger clogged?
- Check if energy save function is operated.



Check point 2. Check outdoor unit operation

- Check if outdoor unit is operating.
- Check any objects that obstruct the air flow route.
- Check if heat exchanger is clogged.
- Is the valve open?



Check point 3. Check site condition

- Is capacity of Indoor unit fitted to the room size?
- Any windows open or direct sunlight?



Check point 4. Check Indoor/ Outdoor installation condition

- Check connection pipe (specified pipe length and pipe diameter?)
- Check any loose or removed communication line.

→ If there is an abnormal condition, correct it by referring to the installation manual or the "DESIGN & TECHNICAL MANUAL".



Check point 5. Check Refrigeration cycle

- Check if strainer is clogged (Refer to the figure below).
- Measure gas pressure, and if there is a leakage, correct it.
- Check the electronic expansion valve.
Refer to outdoor unit Electronic Expansion Valve (EEV) in "[Service parts information](#)" on page 03-52.
- Check compressor.
Refer to compressor in "[Service parts information](#)" on page 03-52.
Refer to inverter compressor in "[Service parts information](#)" on page 03-52.

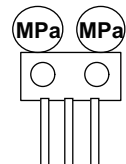

NOTE: When recharging the refrigerant, make sure to perform vacuuming, and recharge the specified amount.



End

NOTES:

- Strainer normally does not have temperature difference between inlet and outlet as shown below.

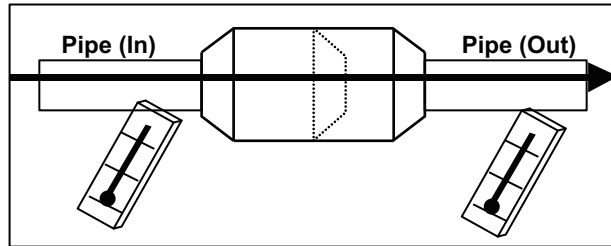

- If there is a difference like shown below, there is a possibility of inside clogged. In this case, replace the strainer.

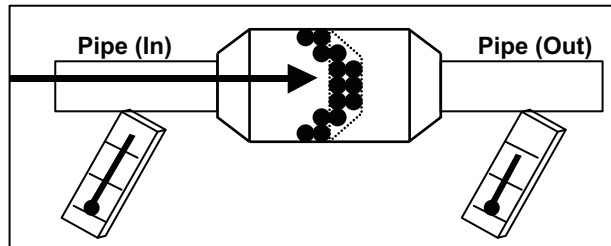

3-5. Abnormal noise

Forecast of cause	Abnormal installation (indoor unit/outdoor unit)
	Fan failure (indoor unit/outdoor unit)
	Compressor failure (outdoor)

Diagnosis method when abnormal noise is occurred

Abnormal noise is coming from Indoor unit.
(Check and correct followings)



- Is main unit installed in stable condition?
- Is the installation of air suction grille and front panel normal?



- Is fan broken or deformed?
- Is the screw of fan loose?
- Is there any object which obstruct the fan rotation?



End

Abnormal noise is coming from Outdoor unit.
(Check and correct followings)



- Is main unit installed in stable condition?
- Is fan guard installed normally?



- Is fan broken or deformed?
- Is the screw of fan loose?
- Is there any object which obstruct the fan rotation?



Check if vibration noise by loose bolt or contact noise of piping is happening.



Is compressor locked?

- Check Compressor
Refer to compressor and inverter compressor in "[Service parts information](#)" on page 03-52.



End

3-6. Water leaking

Forecast of cause	Erroneous installation
	Drain hose failure

Diagnosis method when water leak occurs

- Is main unit installed in stable condition?
- Is main unit broken or deformed at the time of transportation or maintenance?



- Is drain hose connection loose?
- Is there a trap in drain hose?
- Is drain hose clogged?



Is fan rotating?



End

Diagnosis method when water is spitting out

Is the filter clogged?



Check gas pressure and correct it if there was a gas leak.

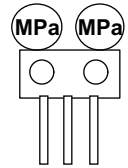

End

4. Service parts information

4-1. Compressor

Diagnosis method of compressor (If outdoor unit LED displays error, refer to troubleshooting)

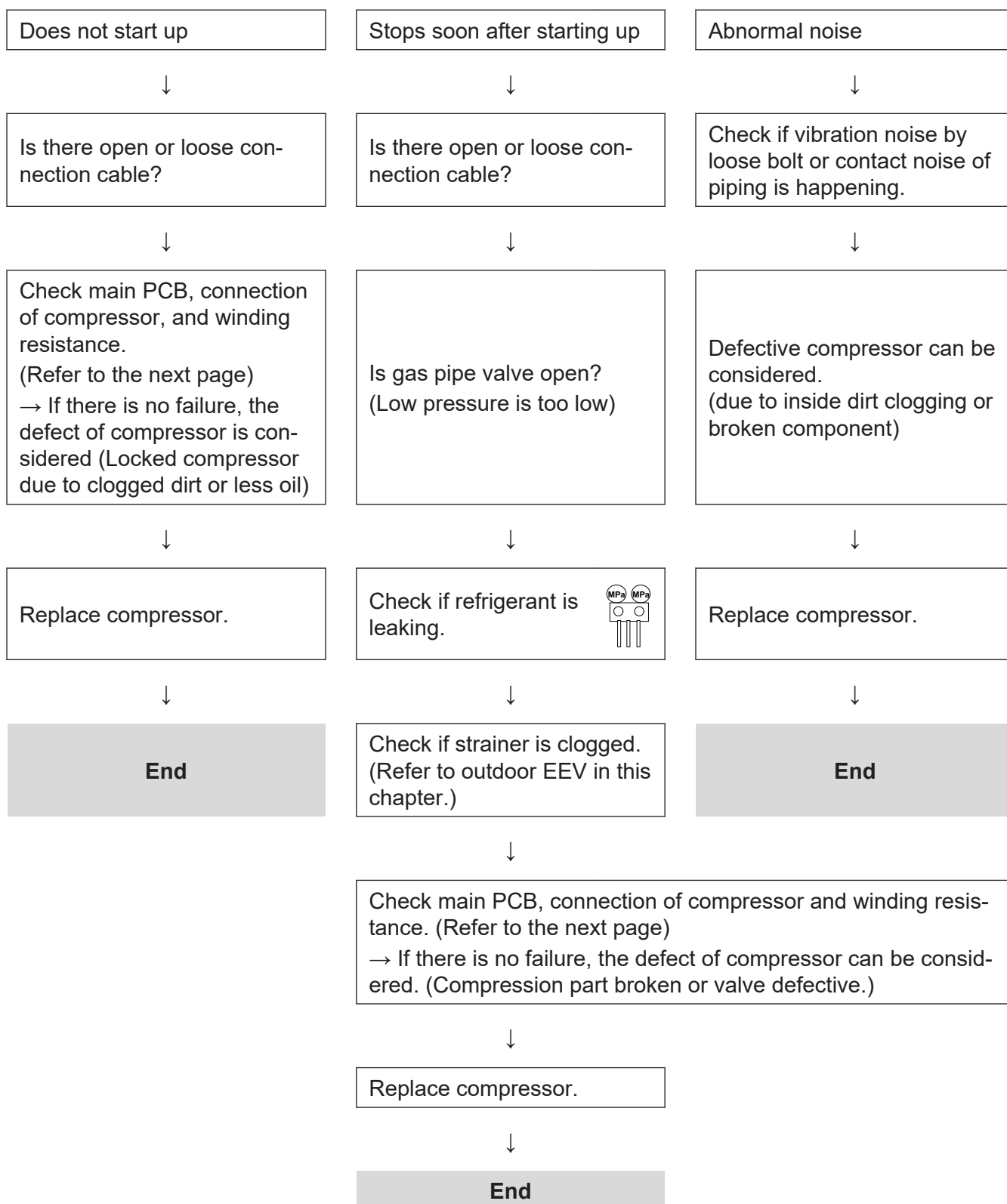

4-2. Inverter compressor

■ Model: AOYG36KRTA

Check point 1. Check connection

- Check terminal connection of compressor (loose or incorrect wiring)

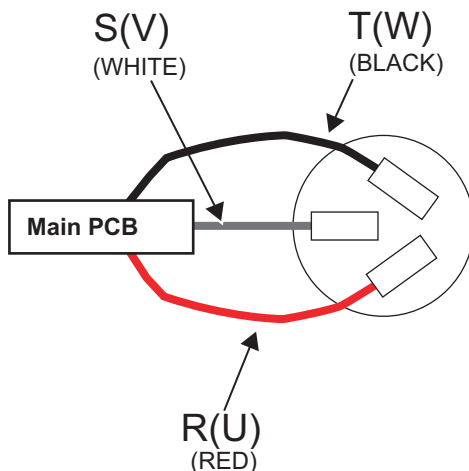

- Check terminal connection of main PCB (loose or incorrect wiring)

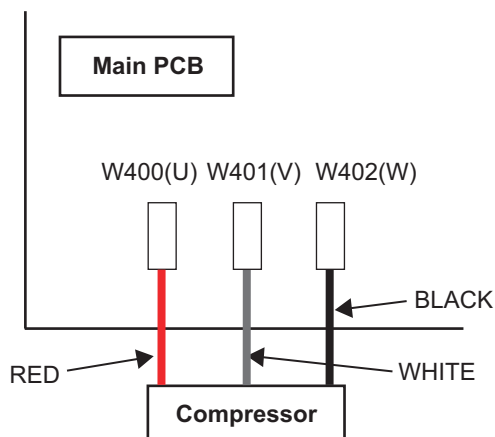

↓

Check point 2. Check winding resistance

Check winding resistance of each terminal.

Resistance value: 2.164 Ω at 25 °C

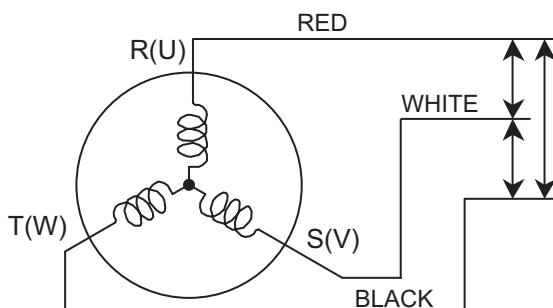

→ If the resistance value is 0 Ω or infinite, replace compressor.

↓

Check point 3. Replace inverter PCB

If check point 1 to 2 do not improve the symptom, replace main PCB.

Models: AOYG45KRTA and AOYG54KRTA

Check point 1. Check connection

- Check terminal connection of compressor (loose or incorrect wiring)

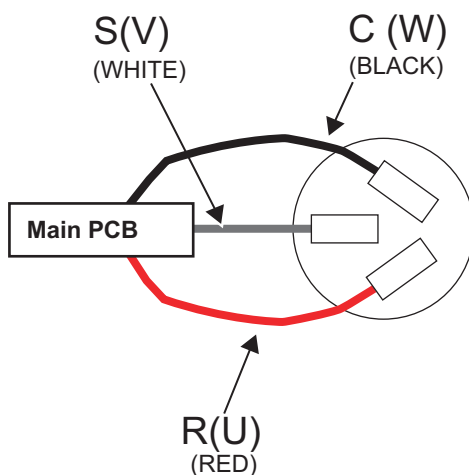

- Check terminal connection of main PCB (loose or incorrect wiring)

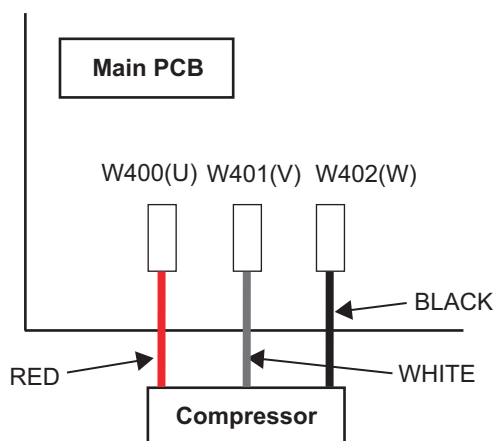

↓

Check point 2. Check winding resistance

Check winding resistance of each terminal.

Resistance value: 1.570 Ω at 20 °C

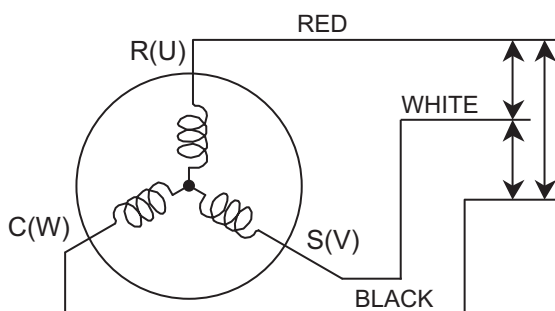

→ If the resistance value is 0 Ω or infinite, replace compressor.

↓

Check point 3. Replace inverter PCB

If check point 1 to 2 do not improve the symptom, replace main PCB.

4-3. Outdoor unit Electronic Expansion Valve (EEV)

■ Models: AOYG36KRTA, AOYG45KRTA, and AOYG54KRTA

Check point 1. Check connections

Check connection of connector. (Loose connector or open cable)

NOTE: For details of wiring diagram, refer to "Wiring diagrams" in Chapter 2. TECHNICAL DATA AND PARTS LIST.

Check point 2. Check coil of EEV

Remove connector, check each winding resistance of coil.

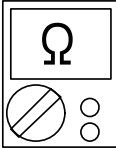
Read wire	Resistance value
1(Red) - 2(Blue)	$46 \Omega \pm 3 \Omega$ at 20°C 
1(Red) - 3(Orange)	
1(Red) - 4(Yellow)	
1(Red) - 5(White)	

→ If Resistance value is abnormal, replace EEV.

Check point 3. Check Voltage from main PCB

Remove connector and check voltage (DC 12 V)

→ If it does not appear, replace main PCB.



Check point 4. Check noise at start up

Turn on the power and check the operation noise.

→ If an abnormal noise does not show, replace main PCB.

Check point 5. Check Opening and Closing Operation of Valve

When valve is closed, it has a temp. difference between inlet and outlet

CLOSE
 Example : Hot Gas

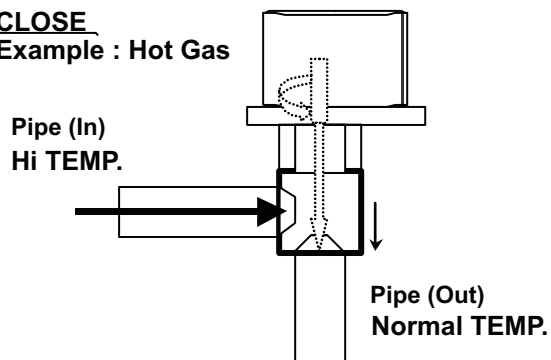

If it is open, it has no temp. difference between inlet and outlet

OPEN
 Example : Hot Gas

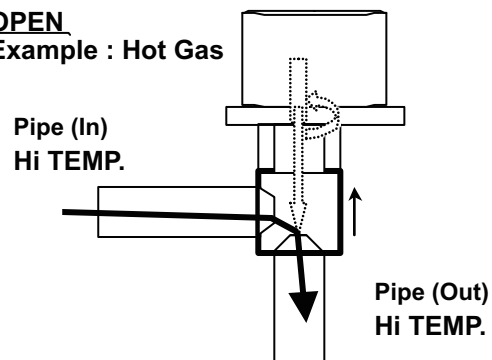

Check point 6. Check strainer

- Strainer normally does not have temperature difference between inlet and outlet as shown below.

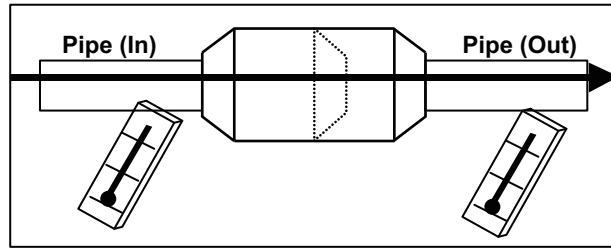

- If there is a difference like shown below, there is a possibility of inside clogged. In this case, replace the strainer.

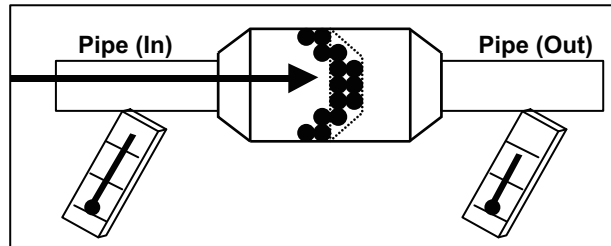

4-4. Indoor unit fan motor

■ Models: AUXG36KRLB, AUXG45KRLB, and AUXG54KRLB

Check point 1. Check rotation of fan

Rotate the fan by hand when operation is off.
 (Check if fan is caught, dropped off or locked motor)
 → If fan or bearing is abnormal, replace it.

Check point 2. Check resistance of indoor fan motor

Refer to below. Circuit-test "Vm" and "GND" terminal

NOTE: Vm: DC voltage, GND: Earth terminal

→ If they are short-circuited (below 300 kΩ), replace indoor fan motor and controller PCB.

Pin number (wire color)	Terminal function (symbol)
1 (Red)	DC voltage (Vm)
2	No function
3	No function
4 (Black)	Earth terminal (GND)
5 (White)	Control voltage (Vcc)
6 (Yellow)	Speed command (Vsp)
7 (Brown)	Feed back (FG)

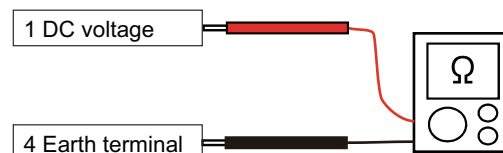

4-5. Outdoor unit fan motor

■ Models: AOYG36KRTA, AOYG45KRTA, and AOYG54KRTA

Check point 1. Check rotation of fan

Rotate the fan by hand when operation is off.
 (Check if fan is caught, dropped off or locked motor)
 → If fan or bearing is abnormal, replace it.

Check point 2. Check resistance of outdoor fan motor

Refer to below. Circuit-test "Vm" and "GND" terminal

NOTE: Vm: DC voltage, GND: Earth terminal

→ If they are short-circuited (below 300 kΩ), replace outdoor fan motor and controller PCB.

Pin number (wire color)	Terminal function (symbol)
1 (Red)	DC voltage (Vm)
2	No function
3	No function
4 (Black)	Earth terminal (GND)
5 (White)	Control voltage (Vcc)
6 (Yellow)	Speed command (Vsp)
7 (Brown)	Feed back (FG)

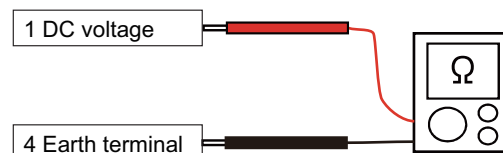

4-6. Pressure switch

■ Models: AOYG36KRTA, AOYG45KRTA, and AOYG54KRTA

- Type of contact

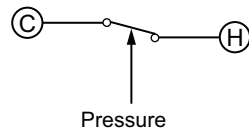

- Characteristics of pressure switch

Pressure switch 1	
Contact: Short → Open	4.2 — 4.05 MPa
Contact: Open → Short	3.2 ± 0.15 MPa

36/45/54 model: P770

4-7. 4-way valve coil (solenoid coil)/4-way valve

■ Models: AOYG36KRTA, AOYG45KRTA, and AOYG54KRTA

Check point 1. Check connection

- Check the connection of connector P60.

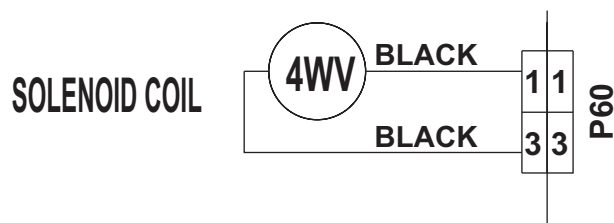

↓

Check Point 2 : Check solenoid coil

Remove P60 from PCB and check the resistance value of coil.

Resistance Value $\approx 1.97 \text{ k}\Omega$

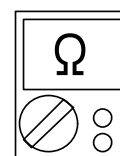
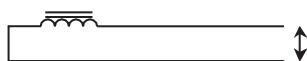

→ If it is Open or abnormal resistance value, replace solenoid coil.

↓

Check Point 3: Check operation of 4 way valve

Check each piping temperature, and confirm the location of the valve by the temperature difference

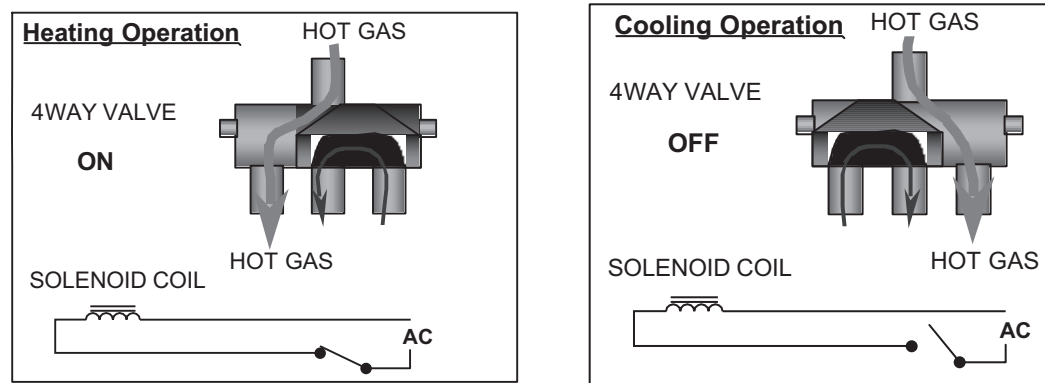

→ If the valve location is not proper, replace 4 way valve.

↓

Check Point 4: Replace main PCB

If none of Checks 1 to 3 apply, replace the main PCB.

5. Thermistor resistance values

5-1. Indoor unit

■ Room temperature thermistor

Temperature (°C)	Resistance (kΩ)	Voltage (V)
-10.0	58.25	0.73
-5.0	44.03	0.93
0.0	33.62	1.15
5.0	25.93	1.39
10.0	20.18	1.66
15.0	15.84	1.94
20.0	12.54	2.22
25.0	10.00	2.50
30.0	8.04	2.77
35.0	6.51	3.03
40.0	5.30	3.27
45.0	4.35	3.49

■ Heat exchanger temperature thermistor

Temperature (°C)	Resistance (kΩ)	Voltage (V)
-30.0	1,013.09	0.24
-25.0	729.08	0.32
-20.0	531.55	0.43
-15.0	382.31	0.56
-10.0	312.27	0.69
-5.0	292.90	0.73
0.0	168.60	1.14
5.0	129.84	1.39
10.0	100.91	1.65
15.0	79.12	1.93
20.0	62.55	2.22
25.0	49.84	2.50
30.0	40.01	2.78
35.0	32.35	3.03
40.0	26.34	3.27
45.0	21.58	3.49
50.0	17.79	3.69
55.0	14.75	3.86
60.0	12.30	4.01
65.0	10.32	4.14

5-2. Outdoor unit

■ Heatsink thermistor

Temperature (°C)	Resistance (kΩ)	Voltage (V)
-30.0	94.26	0.08
-25.0	67.95	0.11
-20.0	49.62	0.15
-15.0	36.68	0.20
-10.0	27.42	0.26
-5.0	20.73	0.34
0.0	15.83	0.43
5.0	12.21	0.55
10.0	9.50	0.68
15.0	7.46	0.84
20.0	5.90	1.01
25.0	4.71	1.21
30.0	3.78	1.42
35.0	3.06	1.64
40.0	2.50	1.88
45.0	2.05	2.11
50.0	1.69	2.35
55.0	1.40	2.58
60.0	1.17	2.81
65.0	0.98	3.02
70.0	0.83	3.22
75.0	0.70	3.41
80.0	0.60	3.58
85.0	0.51	3.73
90.0	0.44	3.87
95.0	0.38	3.99
100.0	0.33	4.10

■ Discharge temperature thermistor

Temperature (°C)	Resistance (kΩ)	Voltage (V)
-30.0	1,013.11	0.06
-25.0	729.09	0.09
-20.0	531.56	0.12
-15.0	392.31	0.16
-10.0	292.91	0.21
-5.0	221.09	0.28
0.0	168.60	0.36
5.0	129.84	0.46
10.0	100.91	0.57
15.0	79.12	0.71
20.0	62.55	0.86
25.0	49.84	1.03
30.0	40.01	1.23
35.0	32.35	1.43
40.0	26.34	1.65
45.0	21.58	1.88
50.0	17.79	2.11
55.0	14.75	2.34
60.0	12.30	2.57
65.0	10.32	2.79
70.0	8.70	3.00
75.0	7.36	3.19
80.0	6.27	3.37
85.0	5.36	3.54
90.0	4.60	3.69
95.0	3.96	3.83
100.0	3.43	3.96
105.0	2.98	4.07
110.0	2.60	4.17
115.0	2.27	4.26
120.0	2.00	4.33

■ Heat exchanger temperature thermistor

Temperature (°C)	Resistance (kΩ)	Voltage (V)
-30.0	95.58	0.24
-25.0	68.90	0.32
-20.0	50.31	0.43
-15.0	37.19	0.57
-10.0	27.81	0.73
-5.0	21.02	0.92
0.0	16.05	1.14
5.0	12.38	1.39
10.0	9.63	1.65
15.0	7.56	1.93
20.0	5.98	2.21
25.0	4.77	2.49
30.0	3.84	2.77
35.0	3.11	3.02
40.0	2.53	3.26
45.0	2.08	3.48
50.0	1.71	3.68
55.0	1.42	3.85
60.0	1.19	4.00
65.0	1.00	4.13
70.0	0.84	4.25
75.0	0.71	4.35
80.0	0.61	4.43

■ Outdoor temperature thermistor

Temperature (°C)	Resistance (kΩ)	Voltage (V)
-30.0	224.33	0.73
-25.0	159.71	0.97
-20.0	115.24	1.25
-15.0	84.21	1.56
-10.0	62.28	1.90
-5.0	46.58	2.26
0.0	35.21	2.61
5.0	26.88	2.94
10.0	20.72	3.25
15.0	16.12	3.52
20.0	12.64	3.76
25.0	10.00	3.97
30.0	7.97	4.14
35.0	6.40	4.28
40.0	5.18	4.41
45.0	4.21	4.51
50.0	3.45	4.59
55.0	2.85	4.65

4. CONTROL AND FUNCTIONS

CONTENTS

4. CONTROL AND FUNCTIONS

1. Compressor frequency control	04-1
1-1. Cooling operation	04-1
1-2. Heating operation	04-3
1-3. Dry operation	04-3
1-4. Compressor frequency at normal start-up	04-4
1-5. Compressor frequency limitation by outdoor temperature	04-6
2. Auto changeover operation	04-8
3. Fan control	04-10
3-1. Indoor fan control.....	04-10
3-2. Outdoor fan control	04-13
4. Louver control	04-15
4-1. Individual louver control	04-15
4-2. All louver control	04-15
4-3. Swing operation.....	04-16
5. Timer operation control	04-17
5-1. Wireless remote control	04-17
5-2. Wired remote control	04-19
6. Defrost operation control	04-22
6-1. Defrost operation in heating operation stopped	04-23
7. Various control	04-24
7-1. Auto restart.....	04-24
7-2. 10 °C HEAT operation	04-24
7-3. ECONOMY operation	04-24
7-4. Fresh air control.....	04-24
7-5. Compressor preheating	04-25
7-6. External electrical heater control	04-25
7-7. Electronic expansion valve control	04-25
7-8. Drain pump control	04-26
7-9. Prevention to restart for 3 minutes (3 minutes st)	04-28
7-10. 4-way valve control.....	04-28
7-11. Human sensor for energy saving.....	04-28
7-12. Peak cut operation	04-28
7-13. Outdoor unit low noise operation	04-29
8. Various protections	04-30
8-1. Discharge gas temperature over-rise prevention control	04-30
8-2. Anti-freezing control (cooling and dry mode)	04-30
8-3. Current release control	04-31
8-4. Indoor unit fan motor over temperature protection.....	04-32
8-5. Compressor temperature protection	04-32
8-6. High pressure protection	04-32

CONTENTS (continued)

8-7. Low outdoor temperature protection	04-32
8-8. High temperature and high pressure release control	04-33

1. Compressor frequency control

1-1. Cooling operation

A sensor (room temperature thermistor) built in the indoor unit body will usually perceive difference or variation between a set temperature and present room temperature, and controls the operation frequency of the compressor.

- If the room temperature is 6.0 °C higher than a set temperature, the compressor operation frequency will attain to maximum performance.
- If the room temperature is 1.0 °C lower than a set temperature, the compressor will be stopped.
- When the room temperature is within the range of +6.0°C to -1.0°C of the setting temperature, the compressor frequency is controlled within the range shown in the table below. However, the maximum frequency is limited in the range shown in the figure below based on the indoor fan mode and the outdoor temperature.

- **Compressor frequency range**

Model name	Minimum frequency	Maximum frequency
AUXG36KRLB	15 rps	98 rps
AUXG45KRLB AUXG54KRLB	17 rps	95 rps

• Limit of maximum speed based on outdoor temperature

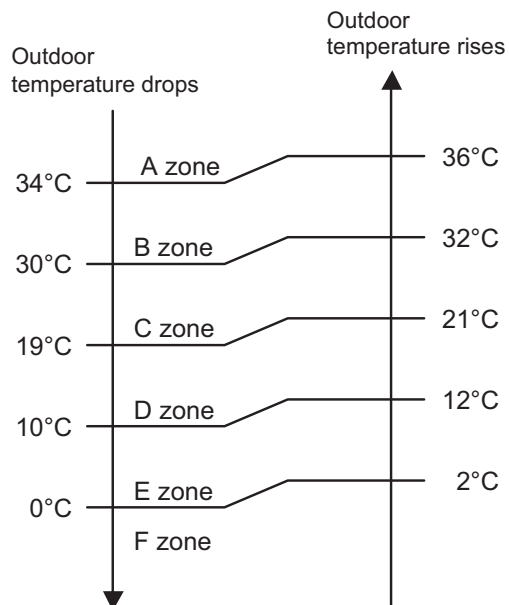

Unit: rps

Model name	Outdoor temperature zone	Indoor unit fan mode			
		HIGH	MED	LOW	QUIET
AUXG36KRLB	A zone	98	64	49	32
	B zone	98	64	49	32
	C zone	77	49	40	32
	D zone	54	40	34	26
	E zone	54	40	34	26
	F zone	54	40	34	26
AUXG45KRLB AUXG54KRLB	A zone	95	66	51	33
	B zone	95	66	51	33
	C zone	80	51	41	33
	D zone	56	41	35	27
	E zone	56	41	35	27
	F zone	56	41	35	27

CONTROL AND FUNCTIONS

CONTROL AND FUNCTIONS

1-2. Heating operation

A sensor (room temperature thermistor) built in indoor unit body will usually perceive difference or variation between setting temperature and present room temperature, and controls operation frequency of compressor.

- If the room temperature is 6.0 °C lower than a set temperature, the compressor operation frequency will attain to maximum performance.
- If the room temperature is 1.0 °C higher than a set temperature, the compressor will be stopped.
- When the room temperature is within the range of +1.0°C to -6.0°C of the setting temperature, the compressor frequency is controlled within the range shown below.

- **Compressor frequency range**

Unit: rps

Model name	Minimum frequency	Maximum frequency
AUXG36KRLB	15 rps	120 rps
AUXG45KRLB AUXG54KRLB	17 rps	120 rps

1-3. Dry operation

The compressor rotation frequency shall change according to the temperature, set temperature, and room temperature variation which the room temperature sensor of the indoor unit has detected as shown in the table below.

Zone is defined by set temperature and room temperature.

- **Compressor frequency range**

Unit: rps

Model name	Outdoor temperature zone	Operating frequency
AUXG36KRLB	X zone	32
	J zone	32
	Y zone	0
AUXG45KRLB AUXG54KRLB	X zone	33
	J zone	33
	Y zone	0

- **Compressor control based on room temperature**

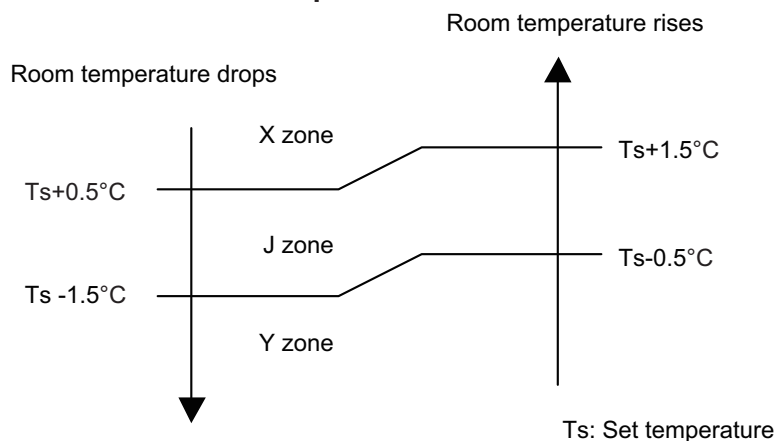

1-4. Compressor frequency at normal start-up

■ Model: AOYG36KRTA

Compressor frequency soon after starting is controlled as below.

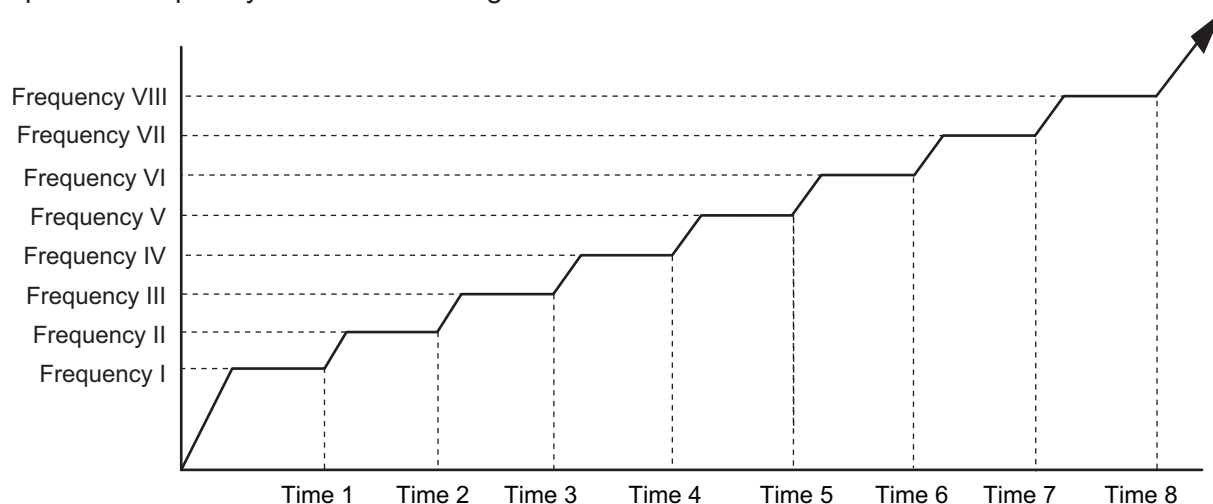

- Normal operation

Frequency (rps)	I 25	II 42	III 53	IV 61	V 65	VI 75	VII 85	VIII 92
Time (sec)	1 90	2 150	3 270	4 330	5 390	6 450	7 570	8 630

- Special operation

Frequency (rps)	I 25	II 42	III 53	IV 61	V 65	VI 75	VII 85	VIII 92
Time (sec)	1 225	2 305	3 605	4 665	5 725	6 785	7 855	8 1,000

NOTES:

- Normal operation:
 - Cooling and dry mode
 - Below 3 hours from the compressor stop and the compressor thermistor $\geq 15\text{ }^{\circ}\text{C}$
 - After defrost operation
 - Other than when the compressor starts for the first time since the breaker turns on
- Special operation:
 - Other than the normal operation condition
 - When the compressor starts for the first time since the breaker turns on

Models: AOYG45KRTA and AOYG54KRTA

Compressor frequency soon after starting is controlled as below.

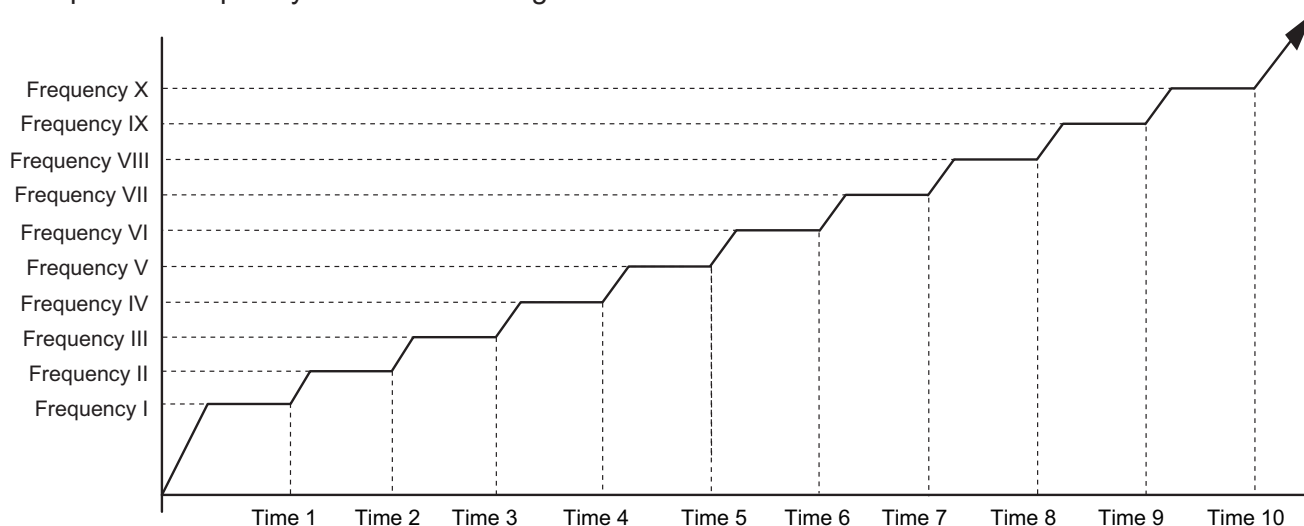

- Normal operation

Frequency (rps)	I	II	III	IV	V	VI	VII	VIII	IX	X
	41	46	51	57	60	72	81	91	100	110
Time (sec)	1	2	3	4	5	6	7	8	9	10
	60	120	180	240	360	420	480	540	600	660

- Special operation

Frequency (rps)	I	II	III	IV	V	VI	VII	VIII	IX	X
	41	46	51	57	60	72	81	91	100	110
Time (sec)	1	2	3	4	5	6	7	8	9	10
	120	185	245	305	605	665	725	785	845	1,000

NOTES:

- Normal operation:
 - Cooling and dry mode
 - Below 3 hours from the compressor stop and the compressor thermistor $\geq 15\text{ }^{\circ}\text{C}$
 - After defrost operation
 - Other than when the compressor starts for the first time since the breaker turns on
- Special operation:
 - Other than the normal operation condition
 - When the compressor starts for the first time since the breaker turns on

1-5. Compressor frequency limitation by outdoor temperature

The minimum compressor frequency is limited by outdoor temperature as below.

- Cooling/Dry mode

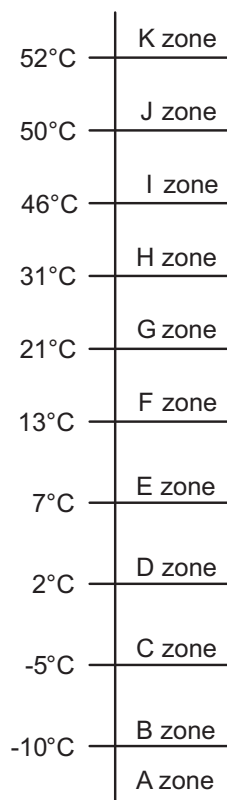

Model name	Outdoor temperature zone	Limitation of compressor frequency
AOYG36KRTA	A zone	55 rps
	B zone	52 rps
	C zone	47 rps
	D zone	39 rps
	E zone	33 rps
	F zone	25 rps
	G zone	18 rps
	H zone	20 rps
	I zone	20 rps
	J zone	21 rps
	K zone	24 rps
AOYG45KRTA AOYG54KRTA	A zone	50 rps
	B zone	47 rps
	C zone	40 rps
	D zone	30 rps
	E zone	22 rps
	F zone	20 rps
	G zone	16 rps
	H zone	16 rps
	I zone	17 rps
	J zone	23 rps
	K zone	28 rps

- Heating mode

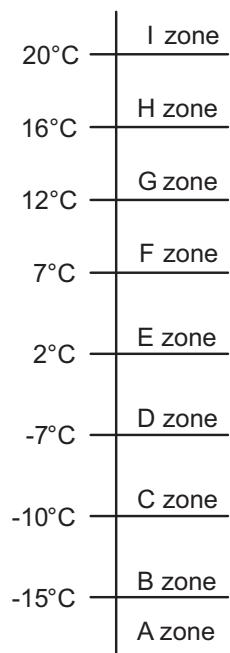

Model name	Outdoor temperature zone	Limitation of compressor frequency
AOYG36KRTA	A zone	58 rps
	B zone	52 rps
	C zone	43 rps
	D zone	38 rps
	E zone	28 rps
	F zone	23 rps
	G zone	20 rps
	H zone	17 rps
	I zone	17 rps
AOYG45KRTA AOYG54KRTA	A zone	46 rps
	B zone	42 rps
	C zone	35 rps
	D zone	32 rps
	E zone	23 rps
	F zone	20 rps
	G zone	17 rps
	H zone	13 rps
	I zone	16 rps

2. Auto changeover operation

When the air conditioner is set to AUTO mode by remote controller, operation starts in the optimum mode from among heating, cooling, dry and monitoring modes. During operation, the optimum mode is automatically switched in accordance with temperature changes. The temperature can be set between 18°C and 30°C in 1.0°C steps.

- When operation starts, indoor fan and outdoor fan are operated for around 1 minute. Room temperature and outdoor temperature are sensed, and the operation mode is selected in accordance with the table below.

Room temperature	Operation mode
$Tr > Ts + 2^{\circ}\text{C}$	Cooling
$Ts + 2^{\circ}\text{C} \geq Tr \geq Ts - 2^{\circ}\text{C}$	Middle zone
$Tr < Ts - 2^{\circ}\text{C}$	Heating

Tr: Room temperature

Ts: Setting temperature

NOTE: When the operation mode is middle zone, indoor unit operation mode is selected as below.

- Same operation mode is selected as outdoor unit.
If outdoor unit is operating in cooling and heating mode, indoor unit will be operated by the same operation mode.
- Selected by outdoor temperature.
If outdoor unit is operating in other than cooling and heating mode, indoor unit will be operated according to the outdoor temperature as below.

Outdoor temp.	Operation mode
25°C or more	Cooling
Less than 25°C	Heating

- When the compressor was stopped for 6 consecutive minutes by temperature control function after the cooling or heating mode was selected as above, operation is switched to monitoring mode and the operation mode selection is done again.
- When the middle zone is selected on the predetermining of the operation mode, the operation mode before the changing to the monitoring mode is selected.

Operation flow chart

Ts: Setting temperature

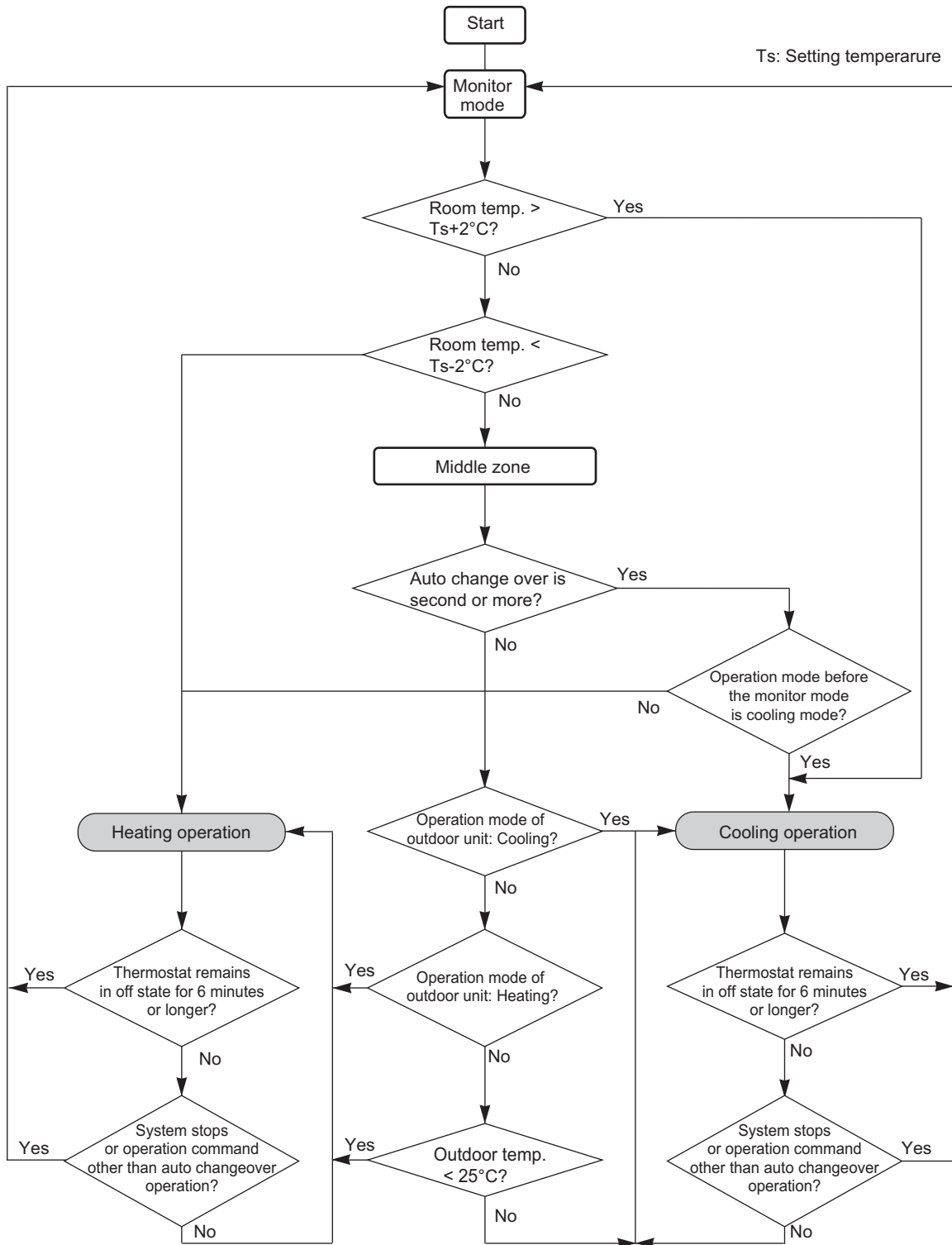

CONTROL AND FUNCTIONS

CONTROL AND FUNCTIONS

3. Fan control

Tr: Room temperature

Ts: Setting temperature

3-1. Indoor fan control

■ Fan speed

Indoor fan speed is defined as below.

Operation mode	Fan mode	Speed (rpm)		
		AUXG36KRLB	AUXG45KRLB	AUXG54KRLB
Heating	HIGH	640	670	690
	MED+	600	630	680
	MED	560	590	630
	LOW	510	530	570
	QUIET	430	470	480
	Cool air prevention	300	300	300
	S-LOW	270	270	270
Cooling/Fan	HIGH	640	670	690
	MED	560	590	630
	LOW	510	530	570
	QUIET	430	470	480
	Soft quiet	300*1	300*1	300*1
	S-LOW	270*2	270*2	270*2
Dry		X zone: 430 J zone: 430	X zone: 470 J zone: 470	X zone: 480 J zone: 480

*1: Fan mode only

*2: Cooling mode only

■ Fan operation

Airflow can be switched in 5 steps such as AUTO, QUIET, LOW, MED, HIGH while indoor unit fan only runs.

When fan mode is set at AUTO, it operates on MED fan speed.

■ Cooling operation

Switch the airflow AUTO, and indoor fan motor will run according to room temperature, as below.

On the other hand, if switched in HIGH—QUIET, indoor motor will run at a constant airflow of COOL operation modes QUIET, LOW, MED, HIGH as shown in “Fan speed” above.

Airflow change over (Cooling: Auto)

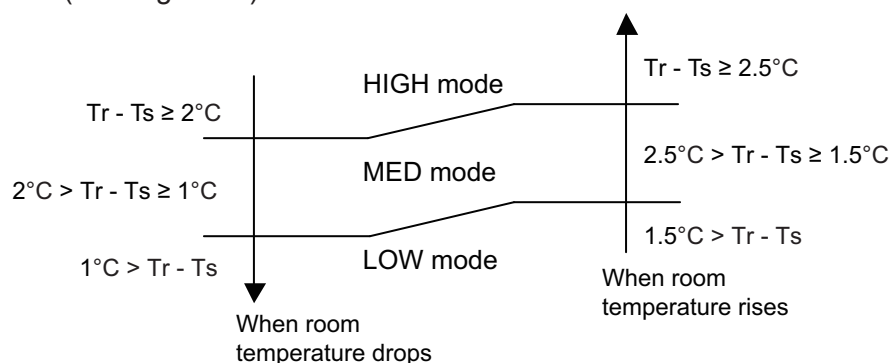

■ Dry operation

During dry operation, fan speed setting can not be changed as shown in “Fan speed” above.

■ Heating operation

Switch the airflow AUTO, and the indoor fan motor will run according to a room temperature, as below.

On the other hand, if switched in HIGH—QUIET, the indoor motor will run at a constant airflow of HEAT operation modes QUIET, LOW, MED, HIGH as shown in “Fan speed” above.

Airflow change over (Heating: Auto)

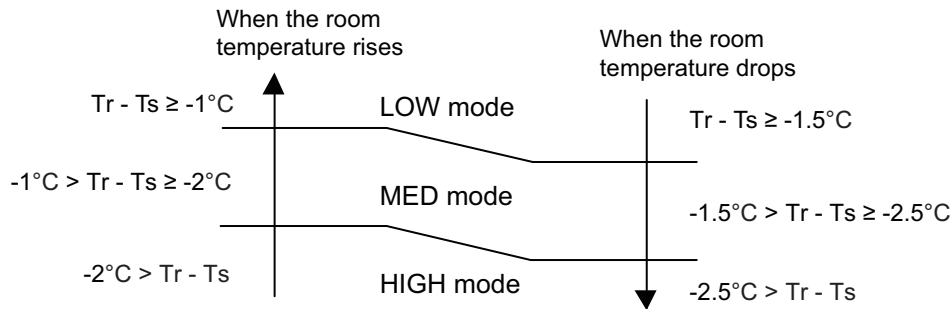

■ Cool air prevention control (heating mode)

The maximum value of the indoor fan speed is set as shown below, based on the detected temperature by the indoor heat exchanger sensor on heating mode.

• Normal operation

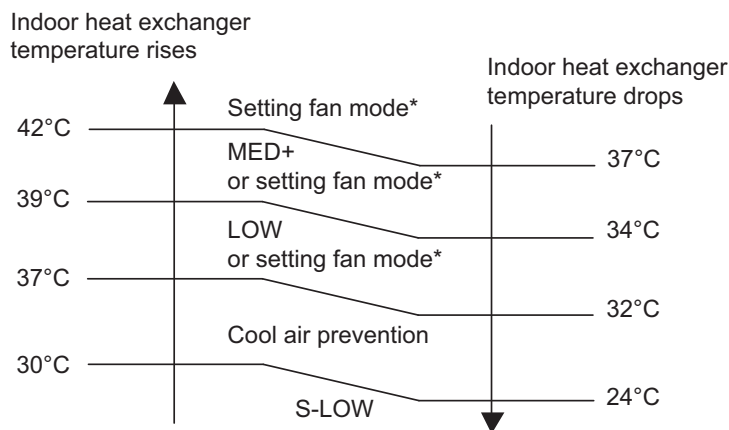

*: Lower speed is selected.

13 minutes later:

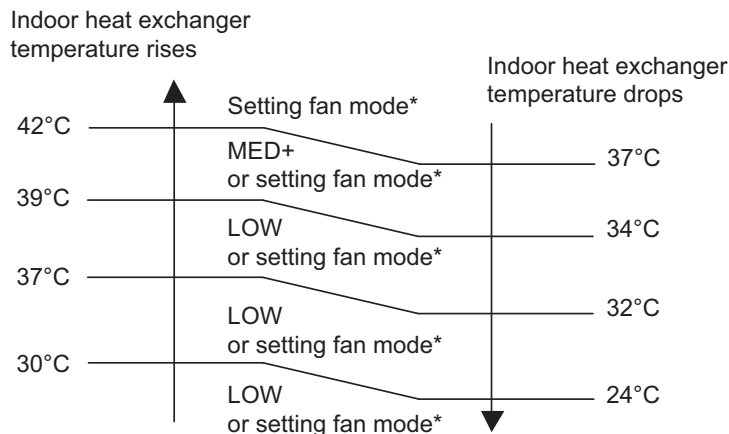

*: Lower speed is selected.

CONTROL AND FUNCTIONS

CONTROL AND FUNCTIONS

• 10 °C HEAT operation

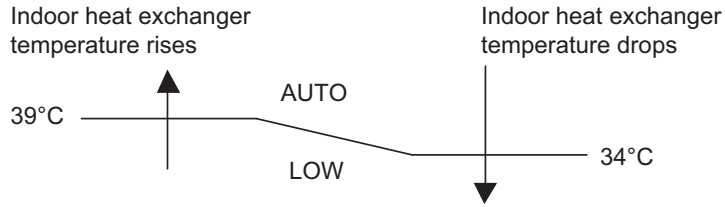

■ Moisture return prevention control (cooling and dry mode)

Switch the airflow AUTO at cooling mode, and the indoor fan motor will run as shown below.

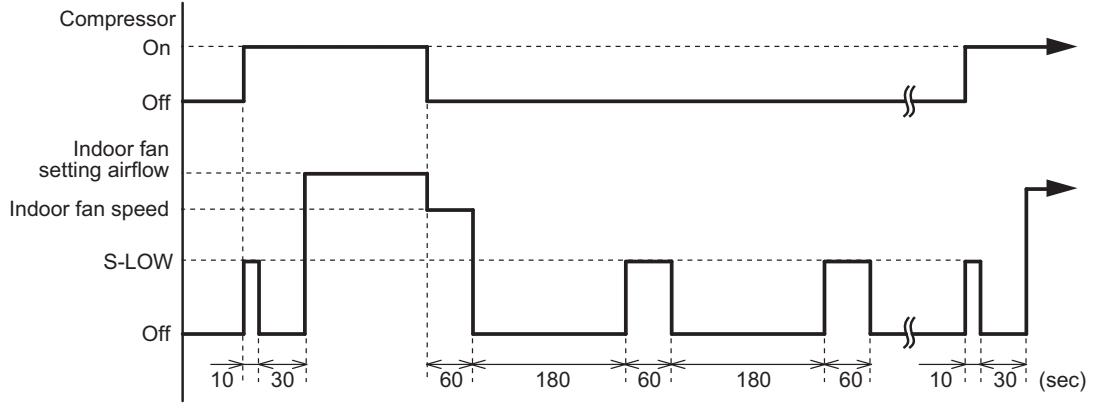

CONTROL AND FUNCTIONS

CONTROL AND FUNCTIONS

3-2. Outdoor fan control

■ Outdoor fan motor

This outdoor unit has a DC fan motor. (Control method is different between AC and DC motors.)

■ Fan speed

● Model: AOYG36KRTA

Fan speed is defined by outdoor temperature and compressor frequency.

Unit: rpm

Fan step	Cooling or dry	Heating
13	830	—
12	830	—
11	740	—
10	700	830
9	650	740
8	570	690
7	570	620
6	570	590
5	570	480
4	540	410
3	480	340
2	400	270
1	270	200
S-HIGH	—	830

- When the compressor frequency increases, the outdoor fan speed also changes to the higher speed.
- When the compressor frequency decreases, the outdoor fan speed also changes to the lower speed.

NOTE: After defrost control on the heating mode, the fan speed is kept higher regardless of the compressor frequency.

Fan speed after defrost control: 830 rpm

● Models: AOYG45KRTA and AOYG54KRTA

Fan speed is defined by outdoor temperature and compressor frequency.

Unit: rpm

Fan step	Cooling or dry	Heating
13	990	—
12	920	—
11	860	—
10	800	990
9	740	900
8	650	820
7	600	740
6	530	650
5	490	540
4	400	460
3	330	380
2	270	290
1	200	200
S-HIGH	—	990

- When the compressor frequency increases, the outdoor fan speed also changes to the higher speed.
- When the compressor frequency decreases, the outdoor fan speed also changes to the lower speed.

NOTE: After defrost control on the heating mode, the fan speed is kept higher regardless of the compressor frequency.

Fan speed after defrost control: 990 rpm

4. Louver control

4-1. Individual louver control

To independently can be set the airflow pattern of each louver as follows:

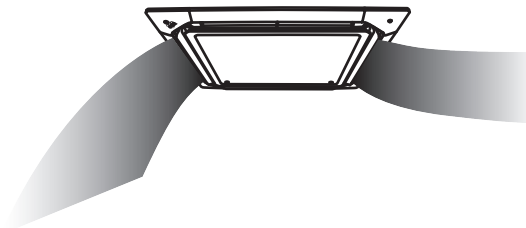

This function is given priority to overall louver control. But this function is release during the following operation.

- Cold air prevention control
- Monitor mode on the auto change over operation
- Defrost operation

The air direction range will change as follows:

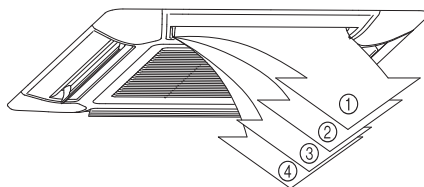

Use the wired remote controller to set this function. This function is only available by 2 wire remote controller.

NOTE: When the 2 wire remote controller is disconnected, clear the individual setting. Otherwise, this setting can't change.

4-2. All louver control

- **All louver operation**

When the mode is selected, the standard louver position of the each mode is set.

model name	Operation mode	Standard Position
AUXG36KRLB	Cooling	2
	Dry	2
	Heating	4
	Monitor	2
AUXG45KRLB AUXG54KRLB	Cooling	2
	Dry	2
	Heating	3
	Monitor	2

NOTES:

- Setting of the wireless remote controller is not displayed on the wired remote controller.
- The setting louver of the individual control function cannot be controlled.

4-3. Swing operation

- To select vertical airflow swing operation
When the swing signal is received, the vertical airflow direction louver starts to swing.
 - Swinging range
 - Cooling mode/dry mode/fan mode: 1 ↔ 4
 - Heating mode: 1 ↔ 4
 - When the indoor fan is S-LOW or stop mode, the swing operation is interrupted and it stops at either upper end or bottom end.

5. Timer operation control

5-1. Wireless remote control

On/Off timer	Program timer	Sleep timer	Weekly timer
○	○	○	—

■ On/Off timer

- Off timer: When the clock reaches the set timer, the air conditioner will be turned off.

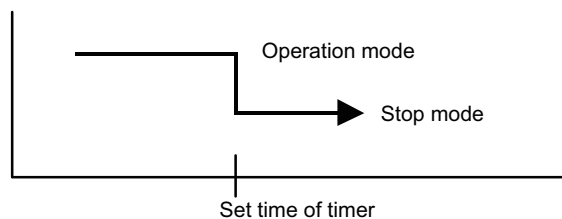

- On timer: When the clock reaches the set timer, the air conditioner will be turned on.

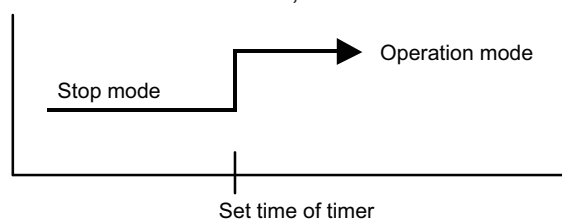

■ Program timer

- The program timer allows the off timer and the on timer to be used in combination one time.

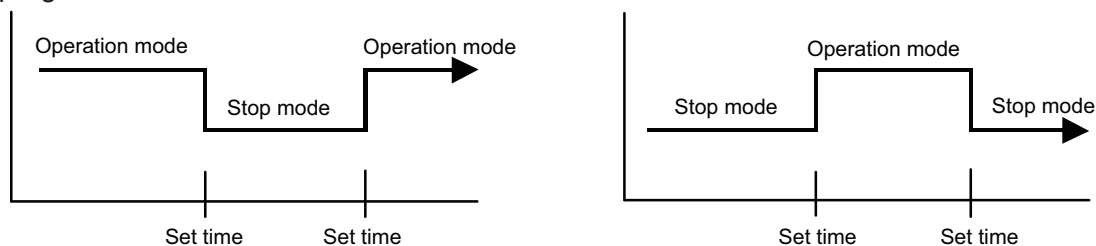

- Operation will start from the timer setting (either off timer and on timer) whichever is closest to the clock current timer setting. The order of operations is indicated by the allow in the remote controller screen.
- Sleep timer operation cannot be combined with on timer operation.

■ Sleep timer

If the sleep timer is set, the room temperature is monitored and the operation is stopped automatically. If the operation mode or the set temperature is change after the sleep timer is set, the operation is continued according to the changed setting of the sleep timer from that time on.

- In the cooling operation mode

When the sleep timer is set, the setting temperature is increased 1°C. It increases the setting temperature another 1°C after 1 hour. After that, the setting temperature is not changed and the operation is stopped at the setting time.

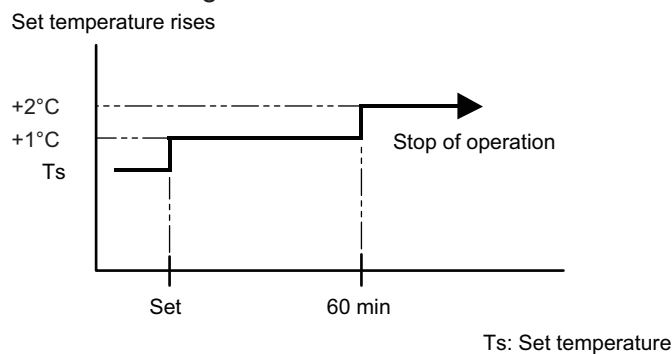

- In the heating operation mode

When the sleep timer is set, the setting temperature is decreased 1°C. It decreases the setting temperature another 1°C every 30 minutes. Upon lowering 4°C, the setting temperature is not changed and the operation is stopped at the setting time.

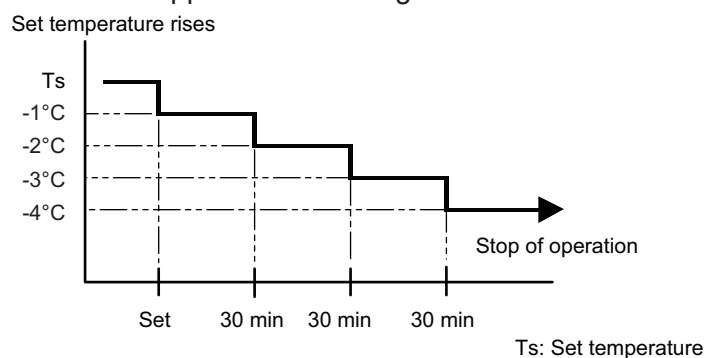

5-2. Wired remote control

On/Off timer	Program timer	Sleep timer	Weekly timer	Temperature set back timer
○	○	○	○	○

■ On/Off timer

- Off timer: When the clock reaches the set timer, the air conditioner will be turned off.

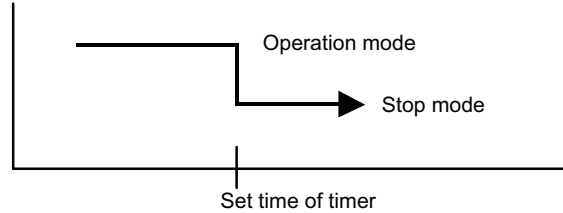

- On timer: When the clock reaches the set timer, the air conditioner will be turned on.

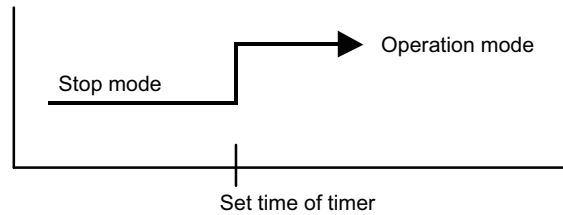

■ Program timer

- The program timer allows the off timer and the on timer to be used in combination one time.

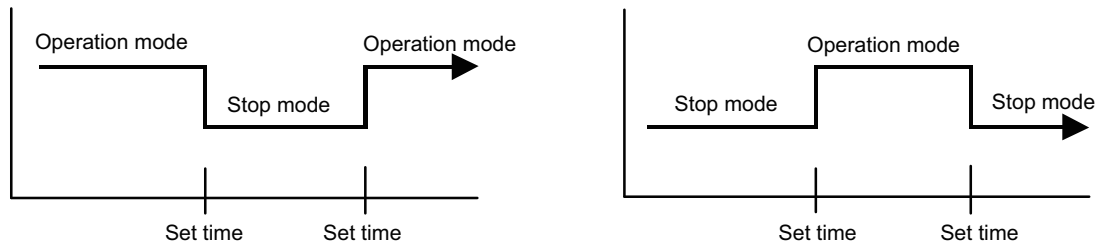

- Operation will start from the timer setting (either off timer and on timer) whichever is closest to the clock current timer setting. The order of operations is indicated by the allow in the remote controller screen.
- Sleep timer operation cannot be combined with on timer operation.

■ Sleep timer

If the sleep timer is set, the room temperature is monitored and the operation is stopped automatically. If the operation mode or the set temperature is change after the sleep timer is set, the operation is continued according to the changed setting of the sleep timer from that time on.

- In the cooling operation mode

When the sleep timer is set, the setting temperature is increased 1°C. It increases the setting temperature another 1°C after 1 hour. After that, the setting temperature is not changed and the operation is stopped at the setting time.

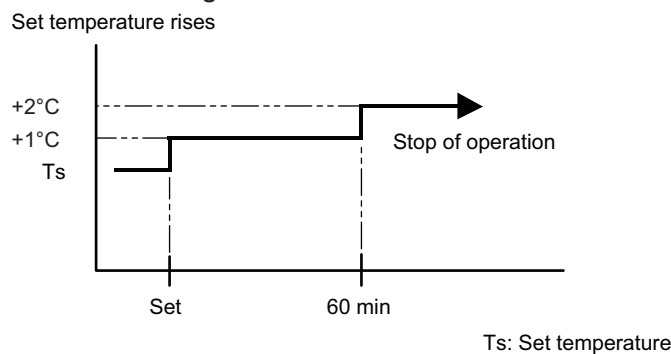

- In the heating operation mode

When the sleep timer is set, the setting temperature is decreased 1°C. It decreases the setting temperature another 1°C every 30 minutes. Upon lowering 4°C, the setting temperature is not changed and the operation is stopped at the setting time.

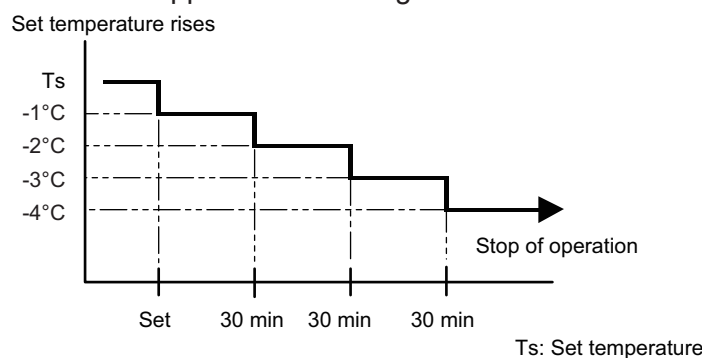

■ Weekly timer

On and off timer can be combined, and up to 4 reservations per day and 28 reservations per week. Before setting the program, set the week and time of the air conditioner at first. If the week and time are not set, the weekly timer will not operate correctly at the setting time.

■ Temperature set back timer

- The SET BACK timer only changes the set temperature for 7 days, it cannot be used to start or stop air conditioner operation.
- The SET BACK timer can be set to operate up to two times per day but only one temperature setting can be used.
- During COOLING/DRY mode, the air conditioner will operate at a minimum of 18°C even if the SET BACK temperature is set to 17°C or lower.

Case of SET BACK timer on the Cooling operation. (Setting temperature :22°C, SET BACK temperature :26°C)

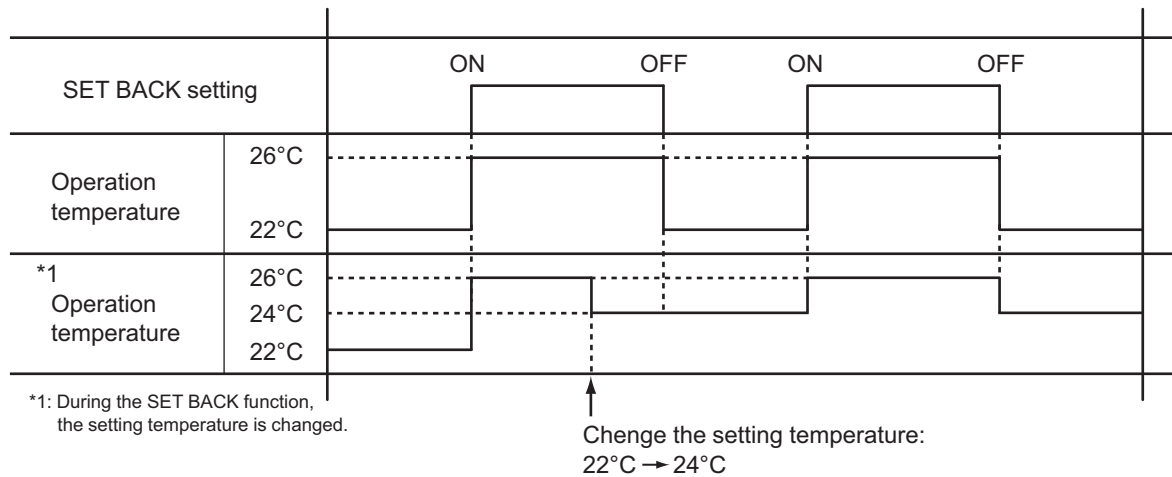

6. Defrost operation control

Tn: Outdoor unit heat exchanger temperature

Ta: Outdoor temperature

Tn10: Temperature at 10 minutes after compressor start

Tnb: Temperature before 5 minutes

• Triggering condition

The defrost operation starts when outdoor unit heat exchanger temperature sensor detects the temperature lower than the values shown below.

– 1st time defrosting after starting operation

Compressor integrating operation time	Less than 17 min.	17 to 57 min.	More than 57 min.
Condition	Does not operate	$T_n \leq -9^\circ\text{C}$ and $T_n - T_a \geq 5$ deg	$T_n \leq -5^\circ\text{C}$

– 2nd time and after

Compressor integrating operation time	Less than 35 min.	More than 35 min.
Condition	Does not operate	$T_n - T_{n10} < -5$ deg ($T_n \leq -10^\circ\text{C}$) $T_n - T_{nb} < -2$ deg ($T_n \leq -10^\circ\text{C}$) $T_n \leq -25^\circ\text{C}$ ($T_a \geq -20^\circ\text{C}$) $T_n \leq T_a - 7^\circ\text{C}$ or $T_n \leq -25^\circ\text{C}$ ($T_a < -20^\circ\text{C}$)

– Integrating defrost (Constant monitoring)

Compressor integrating operation time	More than 240 min. (For long continuous operation)	More than 215 min. (For long continuous operation)	Less than 10 min.* (For intermittent operation)
Condition	$T_n \leq -3^\circ\text{C}$	$T_n \leq -5^\circ\text{C}$	Count of the compressor off: 40 times

*: If the compressor continuous operation time is less than 10 minutes, the number of the compressor off is counted. If any defrost operated, the compressor off count is cleared.

• Release condition

The defrost operation is released when either one of the conditions below is satisfied.

Outdoor unit heat exchanger temperature (after 1 minute or later since compressor start)	12°C or more
Compressor operation time	15 minutes

6-1. Defrost operation in heating operation stopped

If the outdoor unit is frosted when stopping the heating operation, it stops after performing the automatic defrosting operation.

In this time, if the indoor unit operation lamp flashes slowly (6 sec on/2 sec off), the outdoor unit allow the heat exchanger to defrost, and then stop.

• Triggering condition

When all of the following conditions are satisfied in heating operation

- Compressor operation integrating time: 30 minutes or more
- Compressor continuous operation time: 10 minutes or more
- Outdoor unit heat exchanger temperature: -4°C or less

• Release condition

The defrost operation is released when either one of the conditions below is satisfied.

Outdoor unit heat exchanger temperature (after 1 minute or later since compressor start)	12°C or more
Compressor operation time	15 minutes

7. Various control

7-1. Auto restart

When the power was interrupted by a power failure etc. during operation, the operation contents at that time are memorized and when the power is recovered, operation is automatically started with the memorized operation contents.

Operation contents memorized when the power is interrupted	
Operation mode	
Setting temperature	
Fan mode setting	
Timer mode and set time (set by wireless remote controller)	
Airflow direction setting	
Swing	
ECONOMY operation	
10 °C HEAT operation	
Outdoor low noise operation	

7-2. 10 °C HEAT operation

10 °C HEAT operation performs as below setting when pressing 10 °C HEAT button.

Operation mode	Heating
Setting temperature	10°C
Fan mode	AUTO
LED display	Economy
Defrost operation	Operate as normal

7-3. ECONOMY operation

The ECONOMY operation starts by pressing ECONOMY button on the remote controller. The ECONOMY operation is almost the same operation as below settings.

Mode	Cooling/Dry	Heating
Target temperature	Setting temperature +1°C	Setting temperature -1°C

7-4. Fresh air control

The fan motor for Fresh Air is operated in synchronization with the indoor fan operation as below.

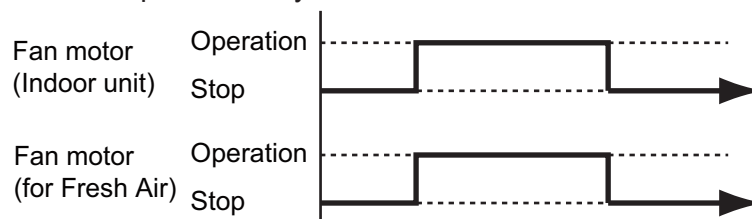

7-5. Compressor preheating

By preheating the compressor, warm airflow is quickly discharged when the operation is started.

- **Triggering condition 1**

- Outdoor temperature $\leq 20^{\circ}\text{C}$

When outdoor temperature reaches 26°C , compressor preheating stops.

- 30 minutes after compressor stopped

- **Triggering condition 2**

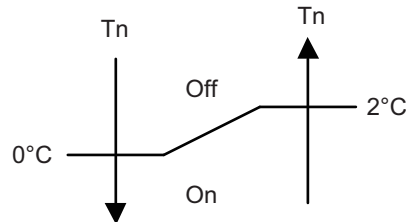

Tn: Outdoor unit heat exchanger temp.

7-6. External electrical heater control

The external electrical heater is operated as below.

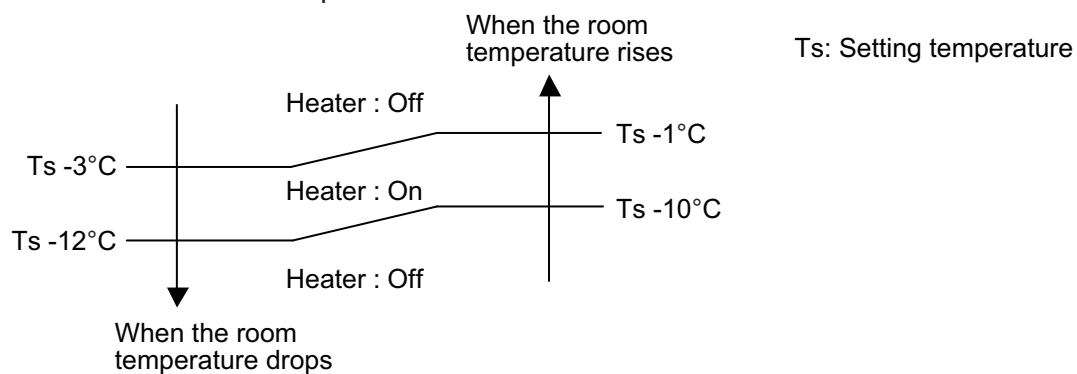

NOTES:

- When the compressor stop, external electric heater is off.
- It operates only in heating mode and when the indoor fan operates. (However, S-LOW is excluded.)

7-7. Electronic expansion valve control

The most proper opening of the electronic expansion valve is calculated and controlled under the present operating condition based on the table below.

Operation mode	Pulse range
Cooling/dry mode	Between 47 and 480 pulses
Heating mode	Between 39 and 480 pulses

NOTE: At the time of supplying the power to the outdoor unit, the initialization of the electronic expansion valve is operated (528 pulses are input to the closing direction).

7-8. Drain pump control

■ Drain control for cooling operation

● During the compressor in operation

- **Triggering condition**
The thermostat is turned on during cooling or dry mode.
- **Operation details**
The drain pump is turned on.
- **Release condition**
 - The thermostat is turned off.
Refer to "When the compressor is not in operation" for the operation after release.
 - The compressor is stopped.
Refer to "When the compressor is not in operation" for the operation after release.
 - The operation is switched to heating mode.
Refer to "When the compressor is not in operation" for the operation after release.
 - The float switch is turned on.
Refer to "Overflow control" for the operation after release.
 - The compressor is stopped by Anti-freezing control.
Refer to "The compressor is stopped by Anti-freezing control" for the operation after release.

● When the compressor is not in operation

- **Triggering condition**
 - The thermostat is turned off.
 - The compressor is stopped.
 - The operation is switched to heating mode.
 - The float switch is turned off.
- **Operation details**
 - Count 180 minutes.
 - Start drain pump intermittent operation.

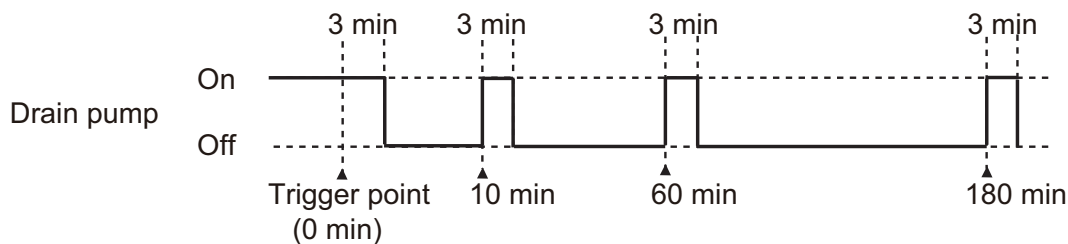

- **Release condition**
 - 3 minutes drain pump operation is finished after 180 minutes count.
 - The operation is switched to cooling or dry mode.
Refer to "During the compressor in operation" for the operation after release.
 - The float switch is turned on.
Refer to "Overflow control" for the operation after release.
- **Operation after release**
The drain pump is turned off and the air conditioner operate according the settings.

● Overflow control

- **Triggering condition**

The float switch is turned on.

- **Operation details**

- The drain pump is turned on.
- When the operation mode is cooling or dry, operate the followings.
 - The compressor is stopped.
 - Then indoor fan control is turned off.

- **Release condition**

- The float switch is turned off.
 - In the case that on the cooling or dry mode the thermostat is on, refer to "[During the compressor in operation](#)" for the operation after release.
 - In other case, refer to "[When the compressor is not in operation](#)" for the operation after release.
- 3 minutes passed

- **Operation after release**

The compressor stopps permanently.

● The compressor is stopped by Anti-freezing control

- **Triggering condition**

During the compressor in operation, the compressor is stopped by Anti-freezing control.

- **Operation details**

The drain pump is kept on in 60 minutes after Anti-freezing control released.

- **Release condition**

60 minutes passed

- **Operation after release**

According to the settings, operate the followings.

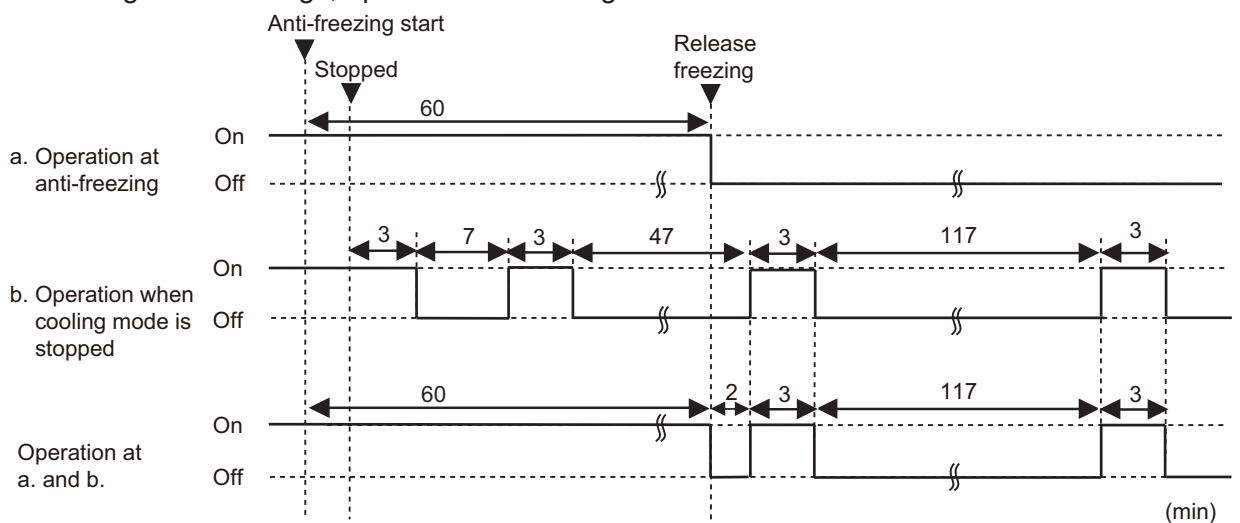

7-9. Prevention to restart for 3 minutes (3 minutes st)

When the compressor fails to start for the number of times below, it does not enter operation status for 3 minutes.

Retry number	30
Retry set number	3

When the compressor fails to start in the retry set number above, the compressor is stopped.

7-10. 4-way valve control

- If heating mode is selected at the compressor start, 4-way valve is energized for heating.
- When the air conditioner is switched between cooling and heating mode, compressor is stopped, and the 4-way valve is switched when the 3 minutes passes and the compressor is started.

7-11. Human sensor for energy saving

If no one enters the room for the set time, the set temperature is automatically controlled. (When someone comes back into the room, the human sensor detect this, and automatically revert to the original settings.)

Operation mode	Operation details (If there is no one in the room for a while)
Cooling/Dry	The setting temperature is increased by maximum 2°C. (Maximum setting temperature: 30°C)
Heating	The setting temperature is decreased by maximum 2°C. (Minimum setting temperature: 16°C)
Auto	Energy saving function is performed automatically for the selected mode (cooling/heating/dry).

Details about detection with the human sensor:

The human sensor detects whether there are people in the room by looking for movement by people in the room.

7-12. Peak cut operation

The current value is limited to reduce the power consumption by external input.

Peak cut level	Level 1	Level 2	Level 3	Level 4
Peak cut for rated capacity	Forced thermostat off	50%	75%	100%

NOTES:

- During defrost operation, peak cut operation becomes invalid.
- Even during the peak cut operation, the operations of current overload, economy, and low noise are effective and the outdoor unit operates by lowest current of them.

7-13. Outdoor unit low noise operation

The compressor frequency and outdoor unit fan speed are limited to reduce the operation noise by external input.

Low noise mode	Low noise mode		Outdoor fan speed	Compressor frequency
			rpm	rps
AOYG36KRTA	Level 1	Cooling/Dry	830	44
		Heating		
	Level 2	Cooling/Dry	830	36
		Heating		
AOYG45KRTA AOYG54KRTA	Level 1	Cooling/Dry	740	60
		Heating		
	Level 2	Cooling/Dry	740	40
		Heating		

NOTES:

- During the defrost operation, the compressor operates by the speed for defrost operation.
- Even during the low noise operation, the operations of current overload, economy, and peak cut are effective and the outdoor unit operates by lowest current of them.

Capacity priority mode

- Operation condition
The function setting is set to 1.
- Capacity check condition
 - Shortage: Compressor frequency > limited compressor frequency for low noise mode
 - Enough: Compressor frequency ≤ limited compressor frequency for low noise mode
- Operation
When detecting the shortage capacity or enough capacity condition continuous 30 minutes, the mode is changed as follows:

- Automatic switching 1 (Level 1 setting)

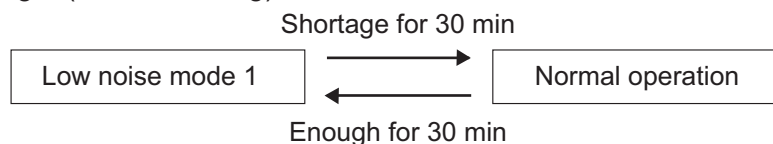

- Automatic switching 2 (Level 2 setting)

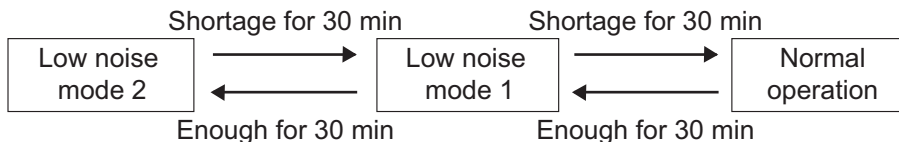

8. Various protections

8-1. Discharge gas temperature over-rise prevention control

The discharge gas temperature sensor (discharge thermistor: outdoor unit side) detects the discharge gas temperature.

- When the discharge temperature becomes higher than the trigger condition, the compressor frequency is decreased as the table below, and it continues to decrease until the discharge temperature becomes lower than the trigger condition.
- When the discharge temperature becomes lower than the release condition, control of compressor frequency is released.
- When the discharge temperature becomes higher than the compressor protection temperature, the compressor is stopped and the indoor unit LED starts blinking.

Trigger condition	104°C
Compressor frequency	-14 rps/120 seconds
Release condition	101°C
Compressor protection temperature	110°C

8-2. Anti-freezing control (cooling and dry mode)

The compressor frequency is decrease in cooling and dry mode when the indoor unit heat exchanger temperature sensor detects the temperature lower than the trigger condition.

When the indoor unit heat exchanger temperature reaches release condition, the anti-freezing control is stopped.

Trigger condition	4°C	
Release condition	Outdoor temp. $\geq 10^{\circ}\text{C}^{*1}$	7°C
	Outdoor temp. $\geq 12^{\circ}\text{C}^{*2}$	
	Outdoor temp. $< 10^{\circ}\text{C}^{*1}$	13°C
	Outdoor temp. $< 12^{\circ}\text{C}^{*2}$	

*1: During the outdoor temperature dropping

*2: During the outdoor temperature rising

8-3. Current release control

The compressor frequency is controlled so that the outdoor unit input current does not exceed the current limit value set according to the outdoor temperature.

The compressor frequency returns according to the operation mode, when the current becomes lower than the release value.

■ Model: AOYG36KRTA

Operation mode	Outdoor temp. (Ta)	Trigger condition	Release condition
Cooling	$52^{\circ}\text{C} \leq \text{Ta}$	3.5 A	3.0 A
	$50^{\circ}\text{C} \leq \text{Ta} < 52^{\circ}\text{C}$	5.5 A	5.0 A
	$42^{\circ}\text{C} \leq \text{Ta} < 50^{\circ}\text{C}$	6.0 A	5.5 A
	$2^{\circ}\text{C} \leq \text{Ta} < 42^{\circ}\text{C}$	7.5 A	7.0 A
	$\text{Ta} < 2^{\circ}\text{C}$	8.5 A	8.0 A
Heating	$20^{\circ}\text{C} \leq \text{Ta}$	5.5 A	5.0 A
	$16^{\circ}\text{C} \leq \text{Ta} < 20^{\circ}\text{C}$	6.0 A	5.5 A
	$12^{\circ}\text{C} \leq \text{Ta} < 16^{\circ}\text{C}$	7.0 A	6.5 A
	$2^{\circ}\text{C} \leq \text{Ta} < 12^{\circ}\text{C}$	7.5 A	7.0 A
	$\text{Ta} < 2^{\circ}\text{C}$	8.5 A	8.0 A

■ Models: AOYG45KRTA and AOYG54KRTA

Operation mode	Outdoor temp. (Ta)	Trigger condition	Release condition
Cooling	$52^{\circ}\text{C} \leq \text{Ta}$	4.5 A	4.0 A
	$50^{\circ}\text{C} \leq \text{Ta} < 52^{\circ}\text{C}$	5.5 A	5.0 A
	$46^{\circ}\text{C} \leq \text{Ta} < 50^{\circ}\text{C}$	6.5 A	6.0 A
	$42^{\circ}\text{C} \leq \text{Ta} < 46^{\circ}\text{C}$	7.5 A	7.0 A
	$2^{\circ}\text{C} \leq \text{Ta} < 42^{\circ}\text{C}$	8.5 A	8.0 A
	$\text{Ta} < 2^{\circ}\text{C}$	10.0 A	9.5 A
Heating	$20^{\circ}\text{C} \leq \text{Ta}$	6.5 A	6.0 A
	$16^{\circ}\text{C} \leq \text{Ta} < 20^{\circ}\text{C}$	7.0 A	6.5 A
	$12^{\circ}\text{C} \leq \text{Ta} < 16^{\circ}\text{C}$	8.0 A	7.5 A
	$2^{\circ}\text{C} \leq \text{Ta} < 12^{\circ}\text{C}$	8.5 A	8.0 A
	$\text{Ta} < 2^{\circ}\text{C}$	10.0 A	9.5 A

8-4. Indoor unit fan motor over temperature protection

When satisfy the following conditions, the protection works.

- After the 90 seconds from the fan operation, detect less than 300 rpm for 10 seconds.
- IPM trip protection works.
- Current overload protection works.

When detecting the above condition, recheck the condition after 6 minutes. When count the twice, the protection works.

- **Protection contents**

Reduce the static pressure 20 Pa. When it does not dissolve even the minimum static pressure condition, work the following operation.

- Fan motor error displayed when less than 300 rpm for 10 seconds is detected after the 90 seconds from the fan operation.
- Fan stop 40 seconds when IPM trip protection works.
- Fan stop 50 seconds when current overload protection works.

8-5. Compressor temperature protection

When the compressor temperature sensor detects higher than the trigger condition below, the compressor is stopped. When the compressor temperature sensor detects the release condition, the protection is released.

Trigger condition	108°C
Release condition	80°C (3 minutes after compressor stop)

8-6. High pressure protection

Trigger condition	Pressure switch: Off (Open: Higher than 4.2 MPa) Compressor stop
Release condition	Pressure switch: On (Close: Lower than 3.2 MPa) (3 minutes after compressor stop) Compressor restart

8-7. Low outdoor temperature protection

When the outdoor temperature sensor detects lower than the trigger condition below, the compressor is stopped.

Operation mode	Cooling/Dry	Heating
Trigger condition	-20°C	
Release condition	-15°C	

8-8. High temperature and high pressure release control

The compressor is controlled as follows.

■ Models: AOYG36KRTA, AOYG45KRTA, and AOYG54KRTA

• Cooling mode

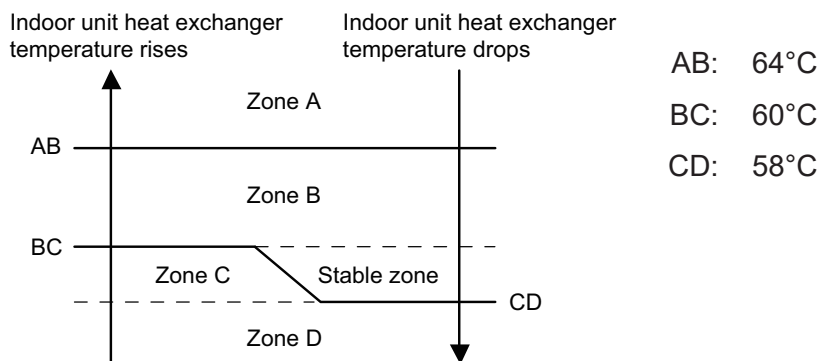

Zone	Operation	
Zone A	Compressor is stopped.	
Zone B	The compressor frequency is decreased.	-7 rps/120 sec.
Zone C	The protection is released and the operation is returned to normal mode.	
Zone D		

• Heating mode

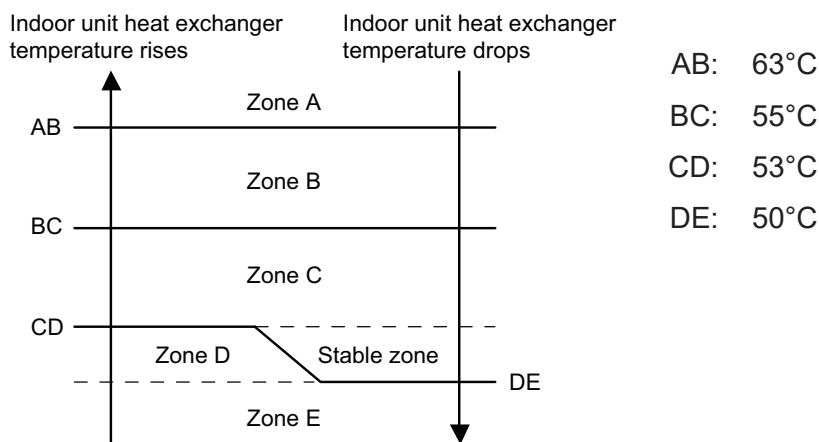

Zone	Operation	
Zone A	Compressor is stopped.	
Zone B	The compressor frequency is decreased.	-15 rps/120 sec.
Zone C		-2 rps/120 sec.
Zone D	The protection is released and the operation is returned to normal mode.	
Zone E		

5. FILED WORKING

CONTENTS

5. FILED WORKING

1. Function settings	05-1
1-1. Function settings on indoor unit.....	05-1
1-2. Function settings by using remote controller	05-3

1. Function settings

To adjust the functions of this product according to the installation environment, various types of function settings are available.

NOTE: Incorrect settings can cause a product malfunction.

1-1. Function settings on indoor unit

By using some components on the PCB, you can change the function settings.

■ Component location

Components on the indoor unit main PCB used for the function settings are located as shown in the following figure.

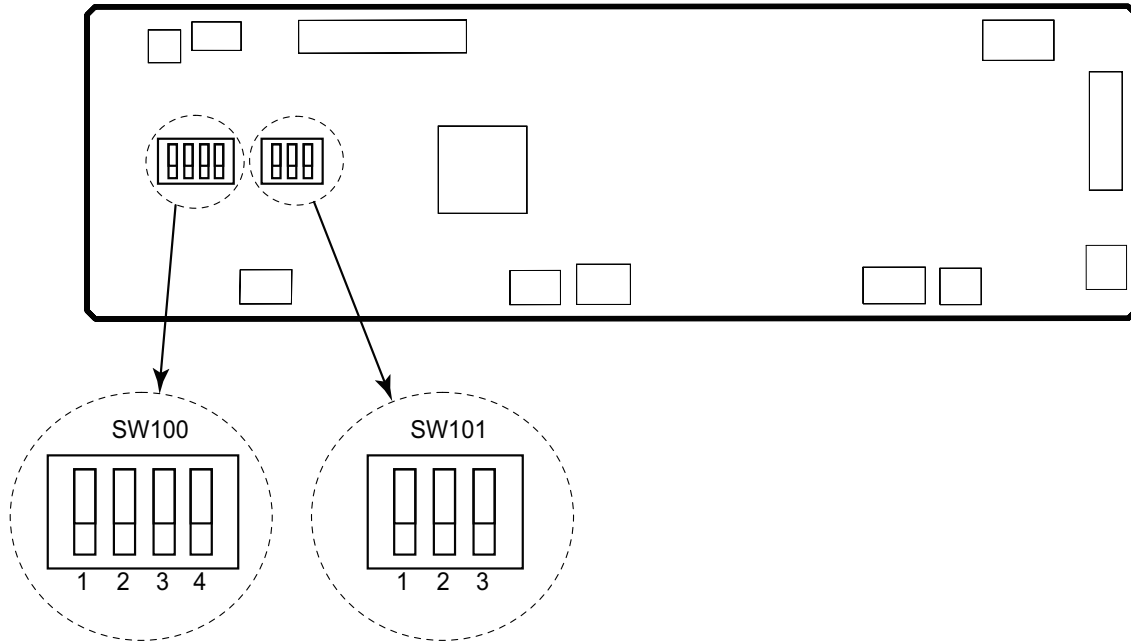

■ DIP switch setting

• SW100: Remote controller address setting

NOTE: Because this setting is normally done automatically when 2-core wired remote controller is installed, setting is unnecessary.

Multiple indoor units can be operated by using one wired remote controller.
Set the unit number of each indoor unit.

Remote controller address	DIP switch number				Factory setting
	1	2	3	4	
00	OFF	OFF	OFF	OFF	◆
01	ON	OFF	OFF	OFF	
02	OFF	ON	OFF	OFF	
03	ON	ON	OFF	OFF	
04	OFF	OFF	ON	OFF	
05	ON	OFF	ON	OFF	
06	OFF	ON	ON	OFF	
07	ON	ON	ON	OFF	
08	OFF	OFF	OFF	ON	
09	ON	OFF	OFF	ON	
10	OFF	ON	OFF	ON	
11	ON	ON	OFF	ON	
12	OFF	OFF	ON	ON	
13	ON	OFF	ON	ON	
14	OFF	ON	ON	ON	
15	ON	ON	ON	ON	

NOTES:

- When connecting Polar 3-core wired remote controller, set the remote controller address in the order of 0, 1, 2,, and 15.
- When different type of indoor units (such as wall-mounted type and cassette type, cassette type and duct type, or other combinations) are connected using group control system, some functions may no longer be available.

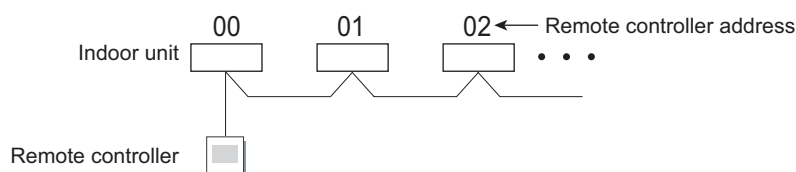

• SW101: Setting change prohibited

1-2. Function settings by using remote controller

Some function settings can be changed on the remote controller. After confirming the setting procedure and the content of each function setting, select appropriate functions for your installation environment.

■ Setting procedure by using remote controller

Remote controller is not attached for this product. For details of the installing remote controller, refer to following information.

- Overview information: Operating manual of the remote controller
- Setting procedure: Installation manual of the remote controller

■ Contents of function setting

Each function setting listed in this section is adjustable in accordance with the installation environment.

NOTE: Setting will not be changed if invalid numbers or setting values are selected.

● Function setting list

	Function no.	Functions
1)	11	Filter sign
2)	20	Ceiling height
3)	22	Outlet directions
4)	23	Vertical airflow direction range control
5)	30/31	Room temperature control for indoor unit sensor
6)	35/36	Room temperature control for wired remote controller sensor
7)	40	Auto restart
8)	42	Room temperature sensor switching
9)	44	Remote controller custom code
10)	46	External input control
11)	48	Room temperature sensor switching (Aux.)
12)	49	Indoor unit fan control for energy saving for cooling
13)	60	Switching functions for external output terminal

1) Filter sign

Select appropriate intervals for displaying the filter sign on the indoor unit according to the estimated amount of dust in the air of the room.

If the indication is not required, select "No indication" (03).

Function number	Setting value	Setting description	Factory setting
11	00	Standard (2,500 hours)	
	01	Long interval (4,400 hours)	
	02	Short interval (1,250 hours)	
	03	No indication	◆

2) Ceiling height

Select the appropriate ceiling height according to the place of installation.

Function number	Setting value	Setting description	Factory setting
20	00	Standard	◆
	01	High ceiling	
	02	Low ceiling	

For the specific height for each setting value, refer to "Installation space" in Chapter "Dimensions" on page 1.

In case of cassette type models:

The ceiling height values are for the 4-way outlet. Do not change this setting in the 3-way outlet mode.

3) Outlet directions

Select the appropriate number of outlet directions according to the installation conditions.

Function number	Setting value	Setting description	Factory setting
22	00	4-way	◆
	01	3-way	

4) Vertical airflow direction range control

To prevent draft, change the setting to "Upward" (01).

Note that the airflow in certain usage conditions may leave the ceiling dirty. In such cases, the use of the optional Panel spacer is recommended.

Function number	Setting value	Setting description	Factory setting
23	00	Standard	◆
	01	Upward	

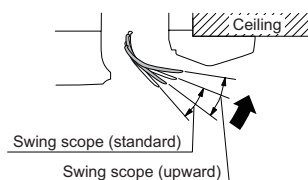

5) Room temperature control for indoor unit sensor

Depending on the installed environment, correction of the room temperature sensor may be required. Select the appropriate control setting according to the installed environment.

The temperature of the room temperature sensor is corrected as follows:

Corrected temp. = Temp. of the room temp. sensor - Correction temp. value

Example of correction:

When the temperature of the room temp. sensor is 26°C and the setting value is "03" (-1.0°C), corrected temp. will be 27°C (26°C - [-1.0°C]).

The temperature correction values show the difference from the Standard setting "00" (manufacturer's recommended value).

Function number		Setting value	Setting description	Factory setting	
30 (For cooling)	31 (For heating)	00	Standard setting	◆	
		01	No correction 0.0 °C		
		02	-0.5 °C	More cooling Less heating	
		03	-1.0 °C		
		04	-1.5 °C		
		05	-2.0 °C		
		06	-2.5 °C		
		07	-3.0 °C		
		08	-3.5 °C		
		09	-4.0 °C		
		10	+0.5 °C	Less cooling More heating	
		11	+1.0 °C		
		12	+1.5 °C		
		13	+2.0 °C		
		14	+2.5 °C		
		15	+3.0 °C		
		16	+3.5 °C		
17	+4.0 °C				

6) Room temperature control for wired remote controller sensor

Depending on the installed environment, correction of the wire remote temperature sensor may be required. Select the appropriate control setting according to the installed environment.

To change this setting, set Function 42 to Both "01".

Ensure that the Thermo Sensor icon is displayed on the remote controller screen.

Function number		Setting value	Setting description	Factory setting	
35 (For cooling)	36 (For heating)	00	Standard setting	◆	
		01	No correction 0.0°C		
		02	-0.5 °C	More cooling Less heating	
		03	-1.0 °C		
		04	-1.5 °C		
		05	-2.0 °C		
		06	-2.5 °C		
		07	-3.0 °C		
		08	-3.5 °C		
		09	-4.0 °C		
		10	+0.5 °C	Less cooling More heating	
		11	+1.0 °C		
		12	+1.5 °C		
		13	+2.0 °C		
		14	+2.5 °C		
		15	+3.0 °C		
		16	+3.5 °C		
		17	+4.0 °C		

7) Auto restart

Enables or disables automatic restart after a power interruption.

Function number	Setting value	Setting description	Factory setting
40	00	Enable	◆
	01	Disable	

NOTE: Auto restart is an emergency function such as for power outage etc. Do not attempt to use this function in normal operation. Be sure to operate the unit by remote controller or external device.

8) Room temperature sensor switching

When using the wired remote controller temperature sensor, change the setting to "Both" (01).

Function number	Setting value	Setting description	Factory setting
42	00	Indoor unit	◆
	01	Both	

00: Sensor on the indoor unit is active.

01: Sensors on both indoor unit and wired remote controller are active.

NOTE: Remote controller sensor must be turned on by using the remote controller.

9) Remote controller custom code

(Only for wireless remote controller)

The indoor unit custom code can be changed. Select the appropriate custom code.

Function number	Setting value	Setting description	Factory setting
44	00	A	◆
	01	B	
	02	C	
	03	D	

10) External input control

"Operation/Stop" mode or "Forced stop" mode can be selected.

Function number	Setting value	Setting description	Factory setting
46	00	Operation/Stop mode 1	◆
	01	(Setting prohibited)	
	02	Forced stop mode	
	03	Operation/Stop mode 2	

11) Room temperature sensor switching (Aux.)

To use the temperature sensor on the wired remote controller only, change the setting to "Wired remote controller" (01).

This function will only work if the function setting 42 is set at "Both" (01).

When the setting value is set to "Both" (00), more suitable control of the room temperature is possible by setting function setting 30 and 31 too.

Function number	Setting value	Setting description	Factory setting
48	00	Both	◆
	01	Wired remote controller	

12) Indoor unit fan control for energy saving for cooling

Enables or disables the power-saving function by controlling the indoor unit fan rotation when the outdoor unit is stopped during cooling operation.

Function number	Setting value	Setting description	Factory setting
49	00	Disable	
	01	Enable	
	02	Remote controller	◆

00: When the outdoor unit is stopped, the indoor unit fan operates continuously following the setting on the remote controller.

01: When the outdoor unit is stopped, the indoor unit fan operates intermittently at a very low speed.

02: Enable or disable this function by remote controller setting.

NOTES:

- As the factory setting, this setting is initially activated.
- Set to "00" or "01" when connecting a remote controller that cannot set the Fan control for energy saving function or connecting a network converter.
To confirm if the remote controller has this setting, refer to the operating manual of each remote controller.

13) Switching functions for external output terminal

Functions of the external output terminal can be switched. For details, refer to “External input and output”.

Function number	Setting value	Setting description	Factory setting
60	00	Operation status	◆
	01—08	(Setting prohibited)	
	09	Error status	
	10	Indoor unit fan operation status	
	11	External heater	