

Split type room air conditioner  
Cassette type (50Hz)

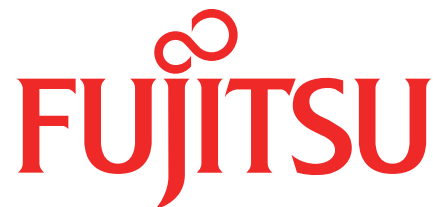

# SERVICE MANUAL



Indoor unit	Outdoor unit
AUYG18LVLB	AOYG18LBCB
UTG-UFYD-W	

## CONTENTS

SPECIFICATIONS .....	1
DIMENSIONS .....	2
REFRIGERANT SYSTEM DIAGRAM ...	4
CIRCUIT DIAGRAM .....	5
PCB CIRCUIT DIAGRAM .....	7
ERROR DETECTION .....	9
PARTS (DECORATION PANEL) .....	10
PARTS (INDOOR UNIT) .....	14
PARTS (OUTDOOR UNIT) .....	18
ACCESSORIES .....	24

# SPECIFICATIONS

## ELECTRICAL DATA

INDOOR UNIT		AUYG18LVLB
DECORATION PANEL		UTG-UFYD-W
OUTDOOR UNIT		AOYG18LBCB
POWER SUPPLY		Single phase, 230 V, 50 Hz
Cooling	Capacity	5.20 kW
	Power consumption	1.62 kW
	EER	3.21 kW/kW
	Operating current	7.2 A
	Max operating current	11.5 A
	Dehumidification	2.2 L/h
Heating	Capacity	6.00 kW
	Power consumption	1.66 kW
	COP	3.61 kW/kW
	Operating current	7.4 A
	Max operating current	13.5 A

## DIMENSIONS

H x W x D

INDOOR UNIT	245 x 570 x 570 mm
DECORATION PANEL	49 x 700 x 700 mm
OUTDOOR UNIT	632 x 799 x 290 mm

## WEIGHT

Net / Shipping

INDOOR UNIT	15 kg / 18 kg
DECORATION PANEL	2.6 kg / 4.5 kg
OUTDOOR UNIT	36 kg / 40 kg

## FAN MOTOR DISCRIMINATION

INDOOR UNIT	MFF-24RVL
OUTDOOR UNIT	MFE-S60VD2F

## FAN SPEED

INDOOR UNIT (Cool / Heat)	High	730 rpm / 830 rpm
	Medium	630 rpm / 730 rpm
	Low	540 rpm / 630 rpm
	Quiet	460 rpm / 500 rpm
OUTDOOR UNIT	Cooling	900 rpm
	Heating	800 rpm

## AIR CIRCULATION

INDOOR UNIT (Fan)	High	680 m <sup>3</sup> /h
	Medium	580 m <sup>3</sup> /h
	Low	490 m <sup>3</sup> /h
	Quiet	410 m <sup>3</sup> /h
OUTDOOR UNIT	Cooling	2,380 m <sup>3</sup> /h
	Heating	2,080 m <sup>3</sup> /h

## NOISE LEVEL

INDOOR UNIT (Cool / Heat)	High	38 dB / 43 dB
	Medium	34 dB / 38 dB
	Low	30 dB / 34 dB
	Quiet	26 dB / 30 dB
OUTDOOR UNIT	Cooling	50 dB
	Heating	50 dB

## COMPRESSOR

DISCRIMINATION	SNB130FZAMC-L2
WEIGHT (with oil)	8.7 kg
DATA	Rolling piston type rotary BLDCM motor, 6 poles

## REFRIGERANT

TYPE	R410A	
PRECHARGED	1,200 g	
FULL CHARGE	Pipe length 15 m	1,200 g
	20 m	1,300 g
	25 m	1,400 g
ADDITIONAL CHARGE	20 g/m	
MAX PIPING HEIGHT DIFFERENCE	15 m	

# DIMENSIONS

INDOOR UNIT  
AUYG18LVLB

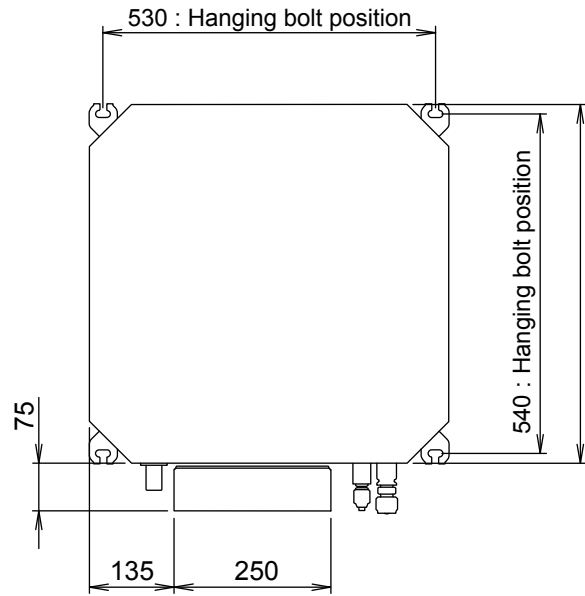

Decoration panel mounting state

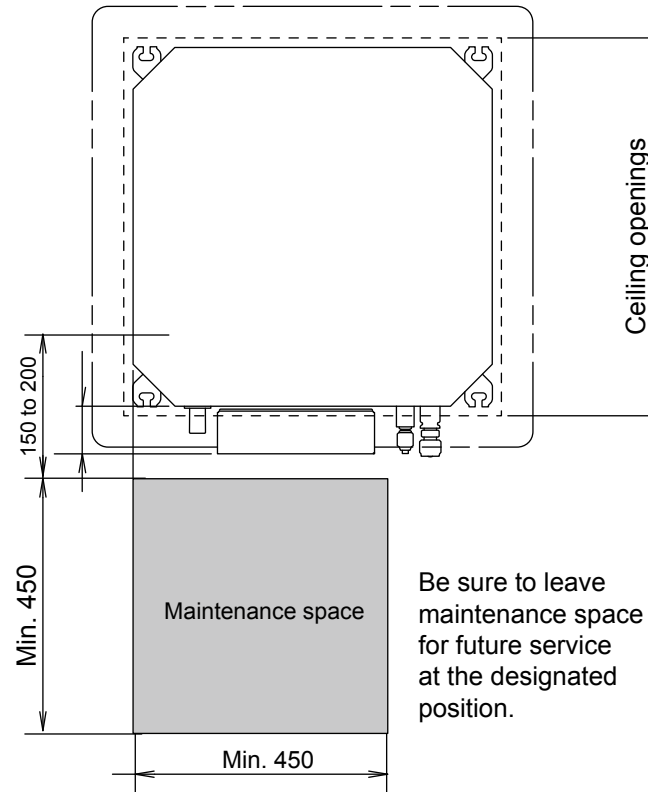

DECORATION PANEL  
UTG-UFYD-W

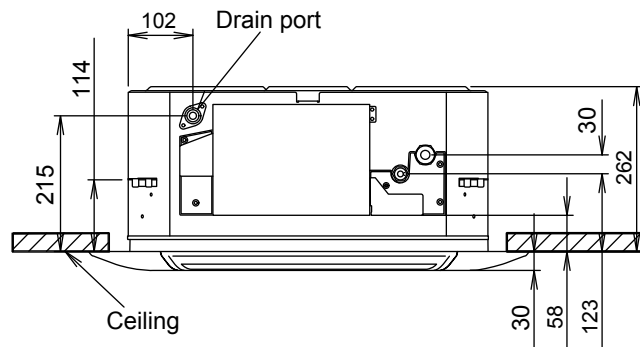
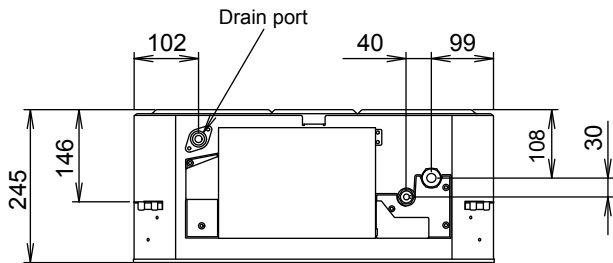
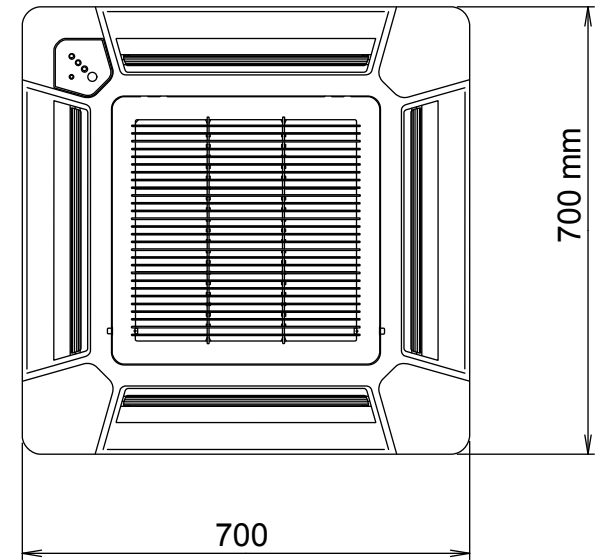
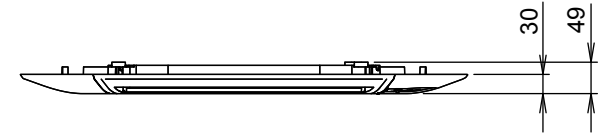

Unit : mm

OUTDOOR UNIT  
AOYG18LBCB

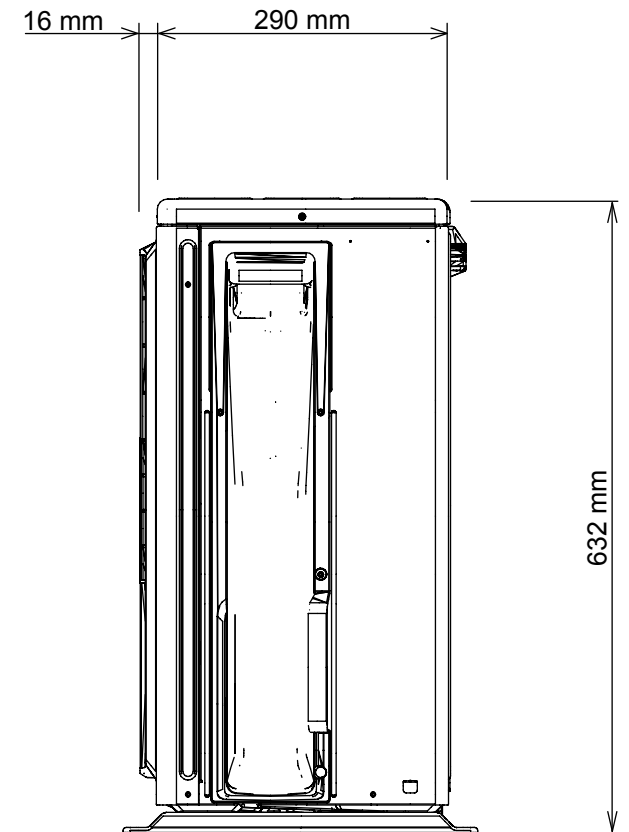
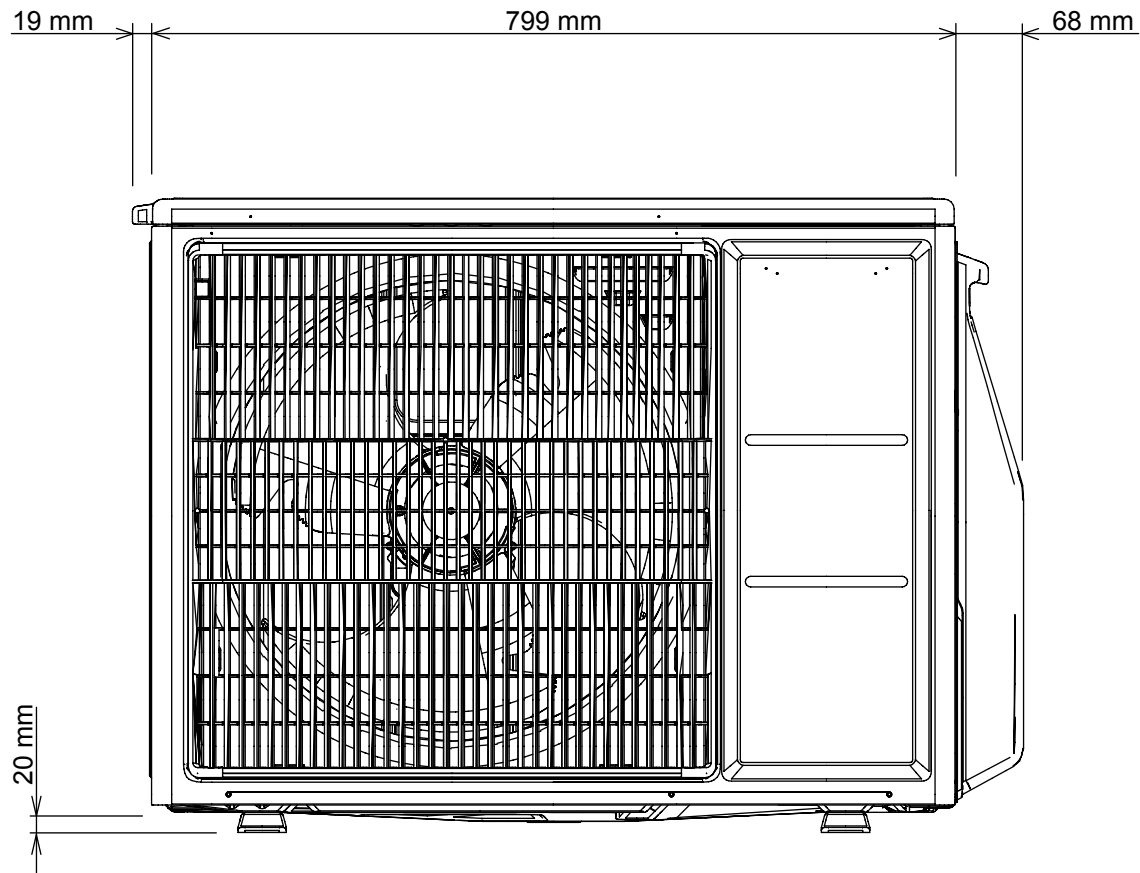
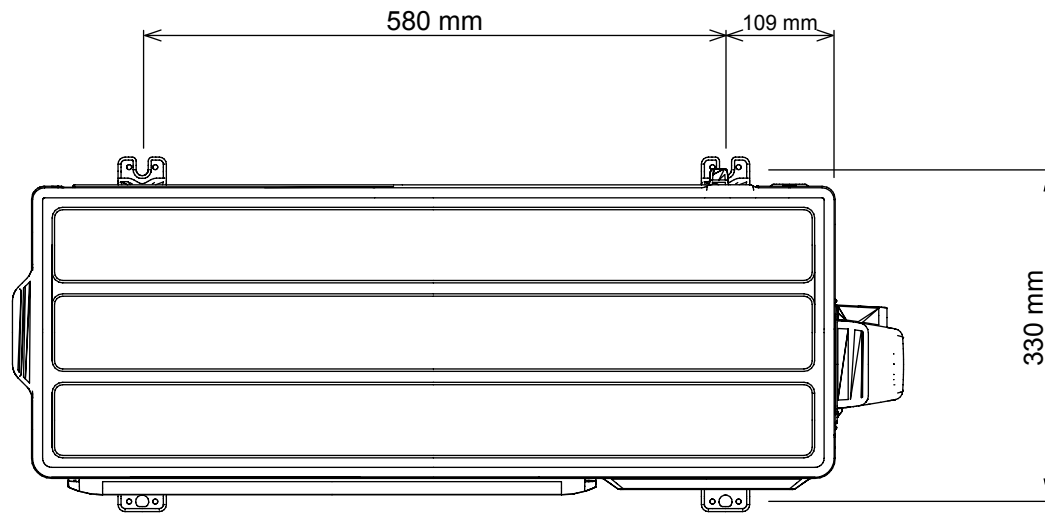

# REFRIGERANT SYSTEM DIAGRAM

Refrigerant direction

—————▶ Cooling

.....▶ Heating

Refrigerant pipe diameter

Liquid : 1/4" (6.35 mm)

Gas : 1/2" (12.7 mm)

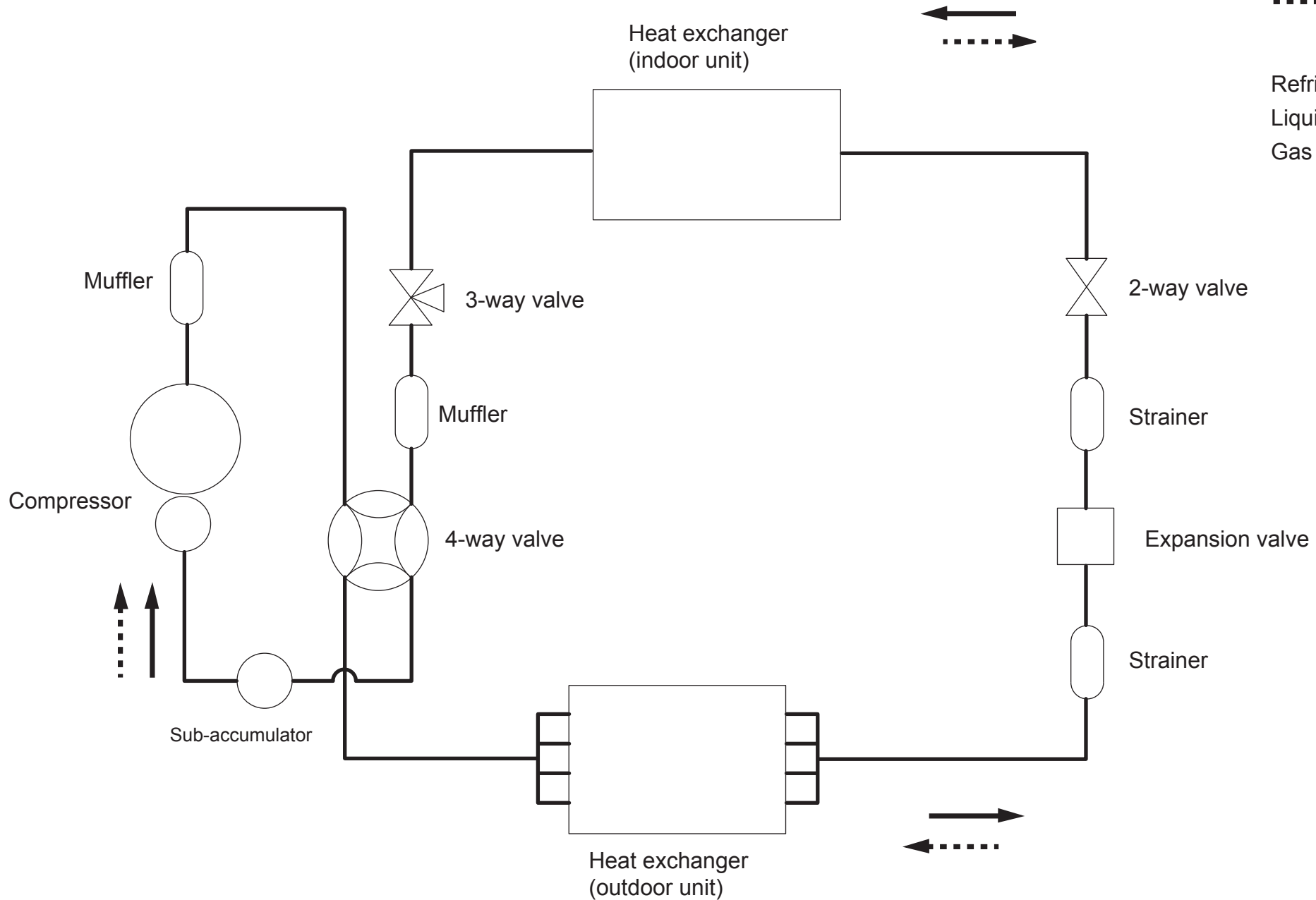

# CIRCUIT DIAGRAM

INDOOR UNIT  
AUYG18LVLB

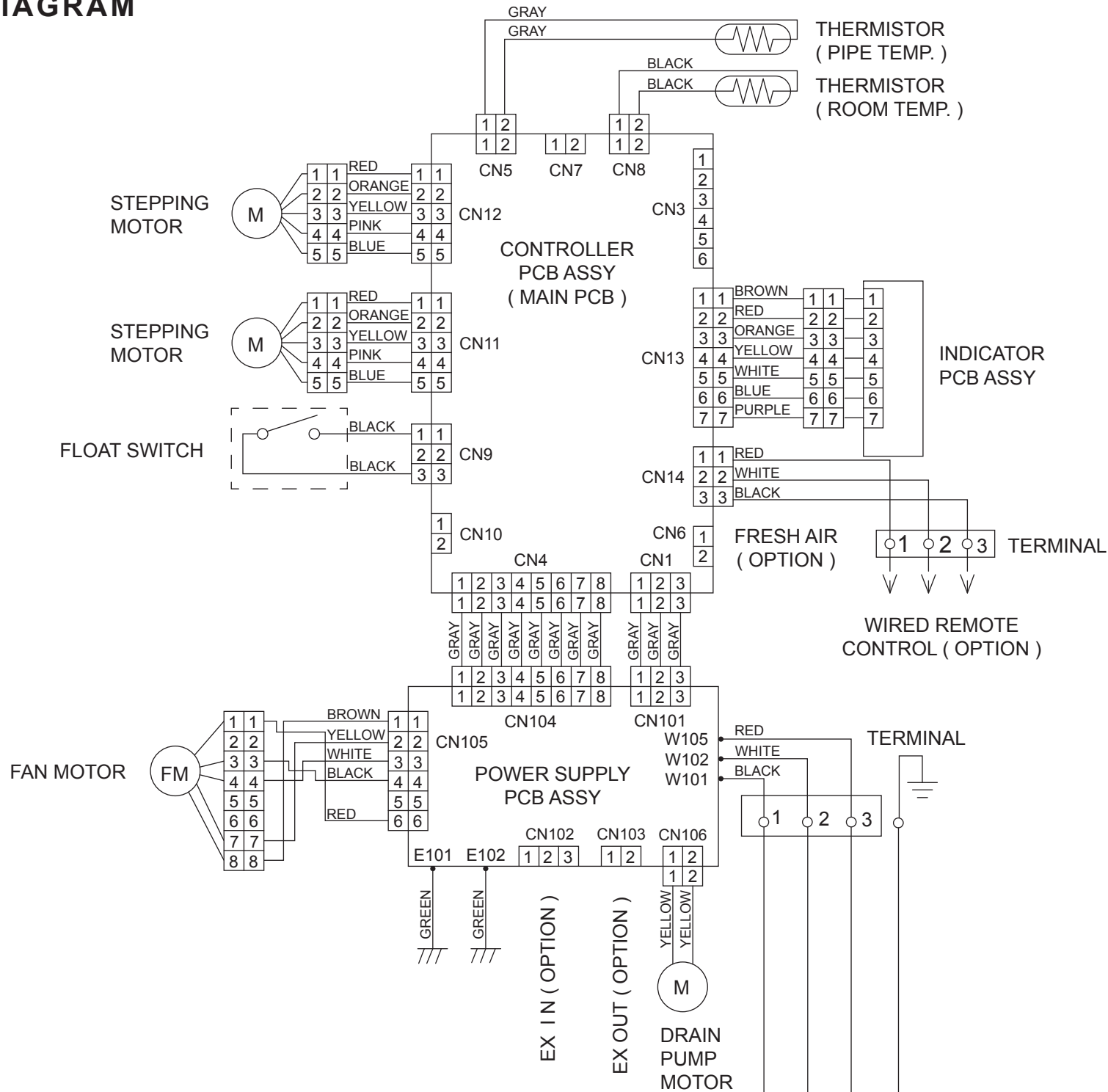

OUTDOOR UNIT  
AOYG18LBCB

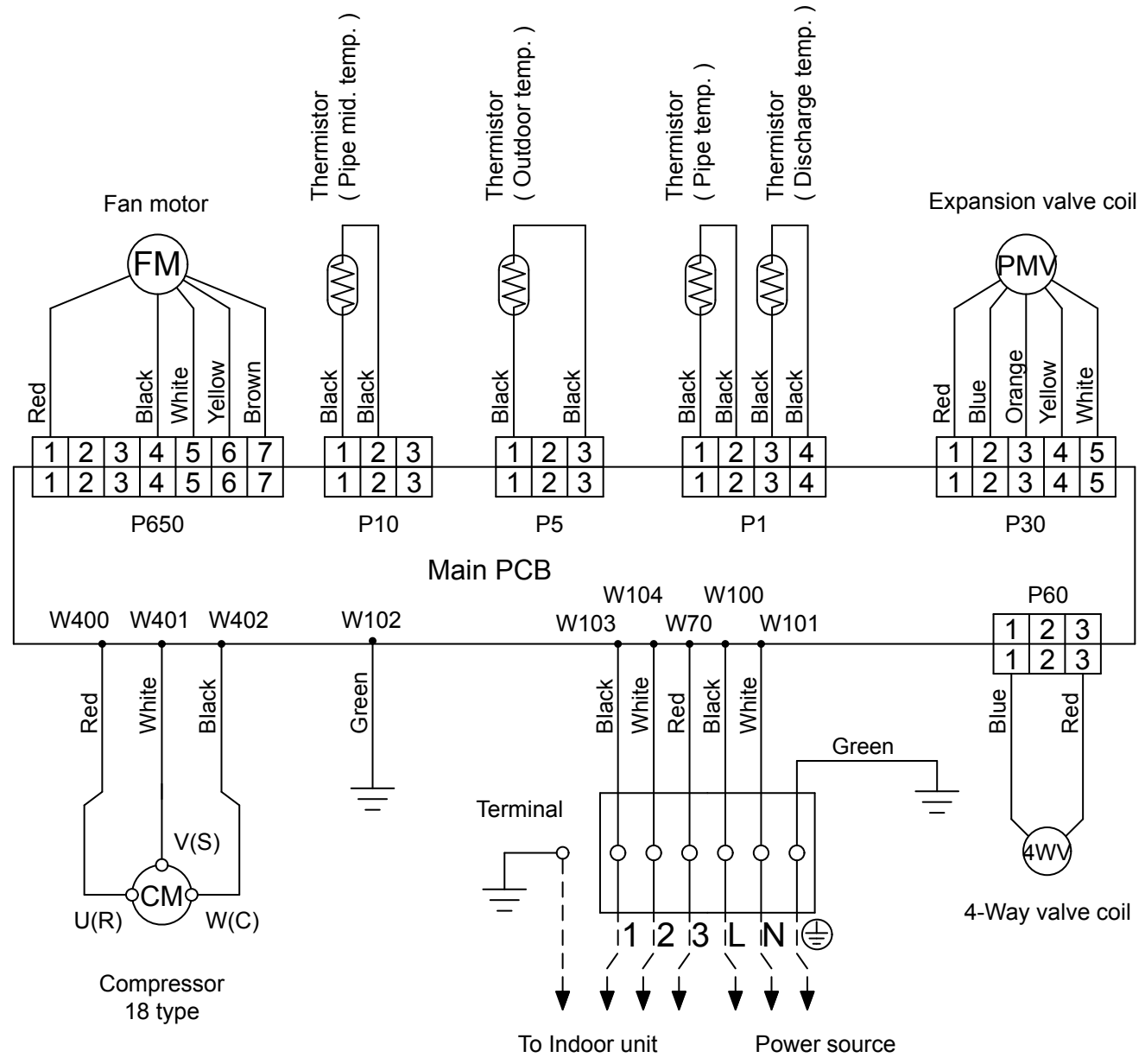

# PCB CIRCUIT DIAGRAM

INDOOR UNIT  
AUYG18LVLB

DECORATION PANEL  
UTG-UFYD-W

CONTROL UNIT  
EZ-0122LHSE

CN8  
Thermistor Characteristics.

Thermistor	Temperature	( 0°C )	( 20°C )	( 30°C )
Thermistor ( Room temp. )		33.6 k Ω	12.5 k Ω	8.0 k Ω
		1.1 V	2.2 V	2.8 V

CN5  
Thermistor Characteristics.

Thermistor	Temperature	( 0°C )	( 20°C )	( 30°C )
Thermistor ( Pipe temp. )		176.3 k Ω	62.9 k Ω	39.6 k Ω
		1.1 V	2.2 V	2.8 V

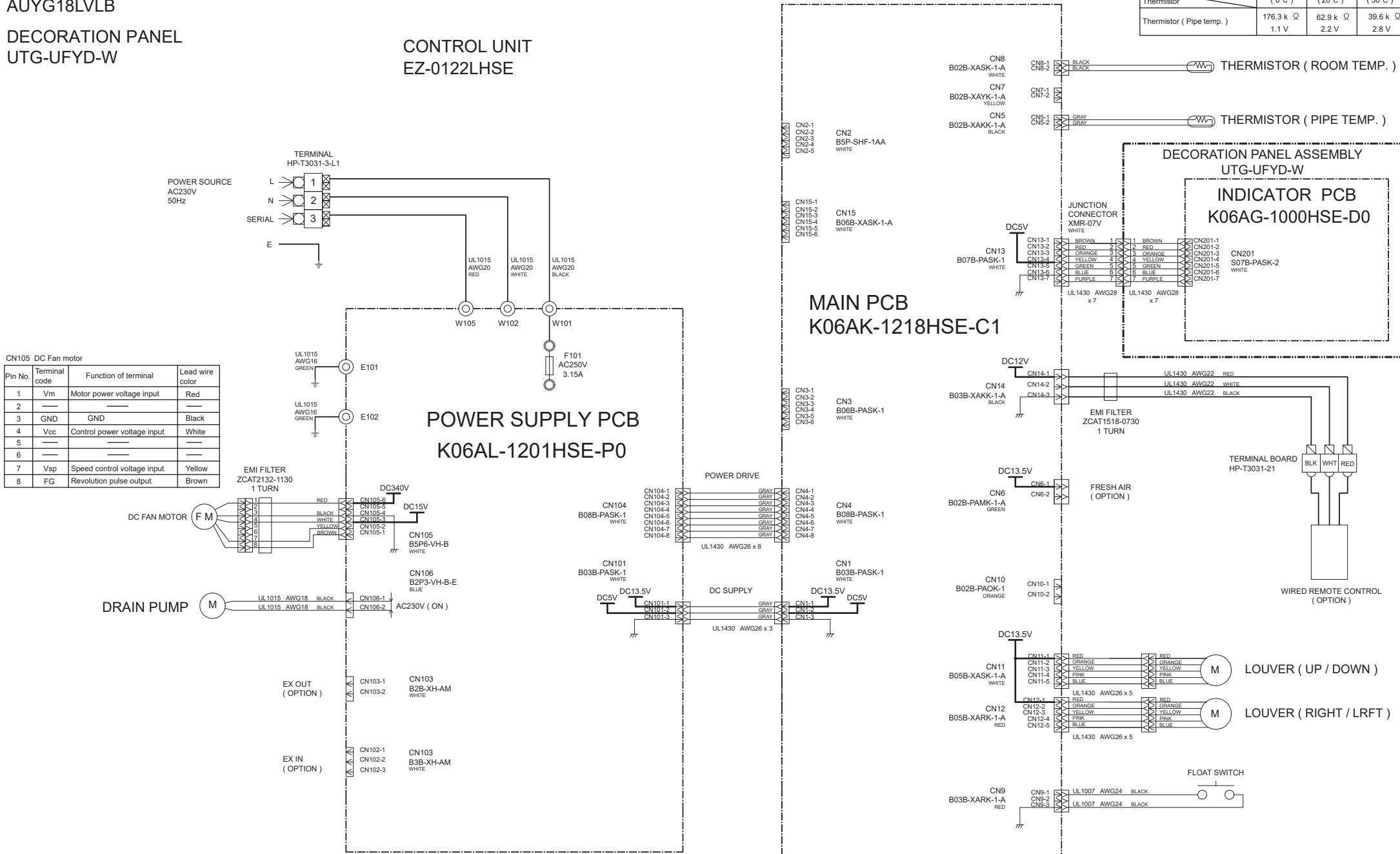

CN105 DC Fan motor

Pin No.	Terminal code	Function of terminal	Lead wire color
1	Vm	Motor power voltage input	Red
2	---	---	---
3	GND	GND	Black
4	Vcc	Control power voltage input	White
5	---	---	---
6	---	---	---
7	Vsp	Speed control voltage input	Yellow
8	FG	Revolution pulse output	Brown

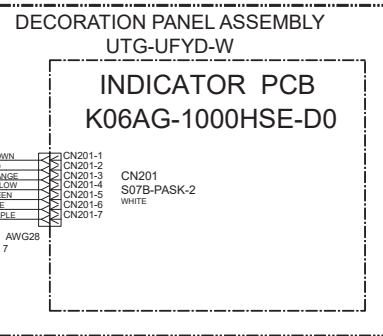



# OUTDOOR UNIT AOYG18LBCB

## INVERTER ASSEMBLY EZ-01703HUE

Compressor (AOYG18LBCB)  
Winding Resistance

U-V	
V-W	1.910 Ω (20°C)
U-W	

Compressor (AOYG24LBCB)  
Winding Resistance

U-V	
V-W	1.299 Ω (20°C)
U-W	

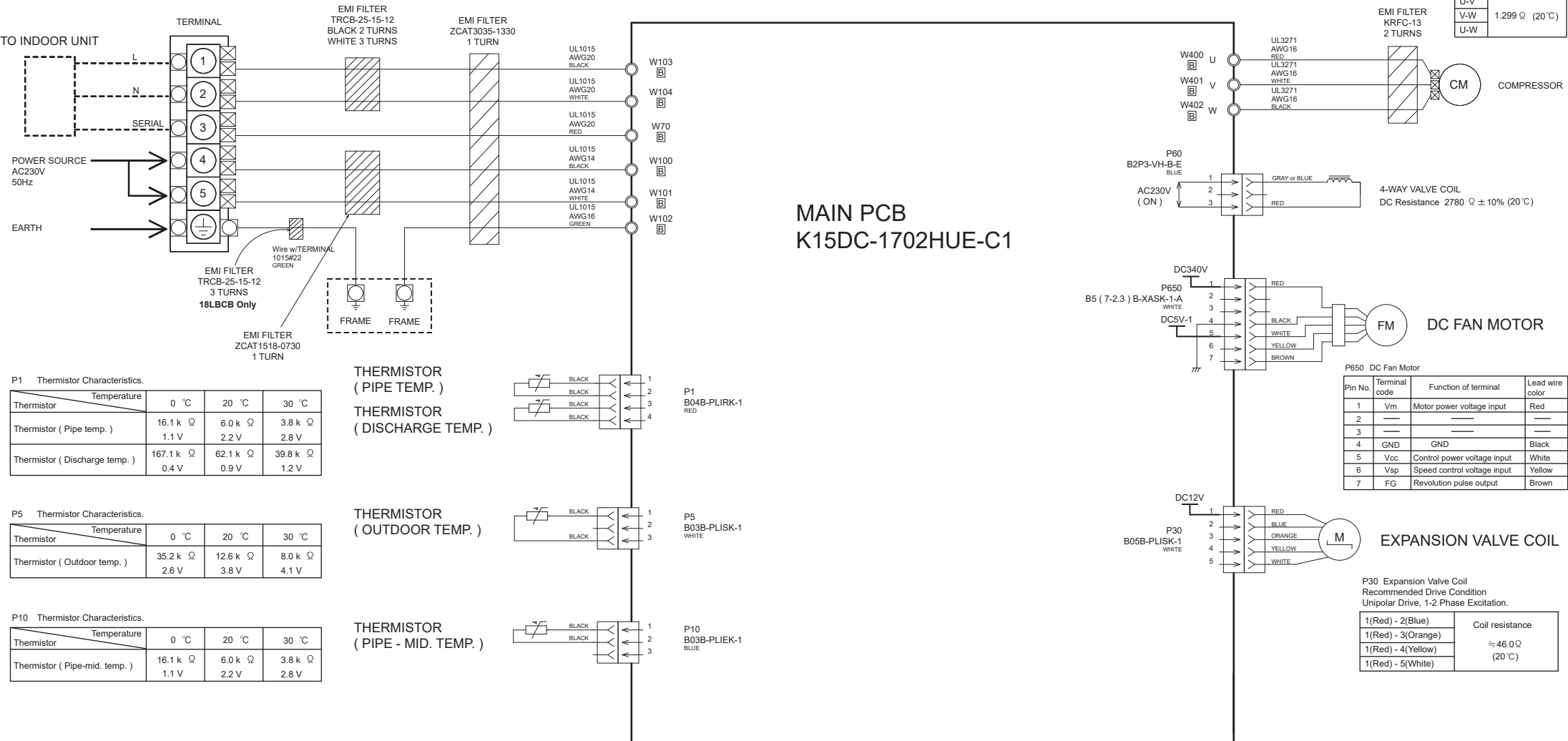

**P1 Thermistor Characteristics.**

Thermistor	Temperature	0 °C	20 °C	30 °C
Thermistor		16.1 k Ω	6.0 k Ω	3.8 k Ω
Thermistor ( Pipe temp. )		1.1 V	2.2 V	2.8 V
Thermistor ( Discharge temp. )		167.1 k Ω	62.1 k Ω	39.8 k Ω
		0.4 V	0.9 V	1.2 V

**P5 Thermistor Characteristics.**

Thermistor	Temperature	0 °C	20 °C	30 °C
Thermistor ( Outdoor temp. )		35.2 k Ω	12.6 k Ω	8.0 k Ω
		2.6 V	3.8 V	4.1 V

**P10 Thermistor Characteristics.**

Thermistor	Temperature	0 °C	20 °C	30 °C
Thermistor ( Pipe-mid. temp. )		16.1 k Ω	6.0 k Ω	3.8 k Ω
		1.1 V	2.2 V	2.8 V

**P650 DC Fan Motor**

Pin No.	Terminal code	Function of terminal	Lead wire color
1	Vm	Motor power voltage input	Red
2	—	—	—
3	—	—	—
4	GND	GND	Black
5	Vcc	Control power voltage input	White
6	Vsp	Speed control voltage input	Yellow
7	FG	Revolution pulse output	Brown

**P30 Expansion Valve Coil**  
Recommended Drive Condition  
Unipolar Drive, 1-2 Phase Excitation.

1(Red) - 2(Blue)	Coil resistance ≈ 46.0 Ω (20 °C)
1(Red) - 3(Orange)	
1(Red) - 4(Yellow)	
1(Red) - 5(White)	

# ERROR DETECTION

## INDOOR UNIT

AUYG18LVLB

and WIRED REMOTE CONTROL

If you use a wireless remote control, the lamp on the photo detector unit will output error codes by way of blinking patterns.

If you use a wired type remote control, error codes will appear on the remote control display. See the lamp blinking patterns and error codes in the table. An error display is displayed only during running.

This is possible only on a wired remote control.

If an error occurs, the following display will be shown. ("Er" will appear in the set room temperature display.)

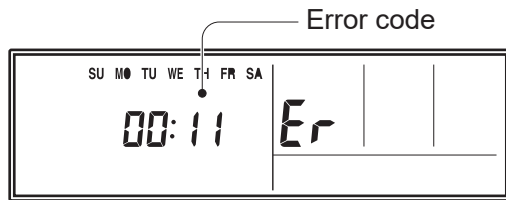

EX. Self-diagnosis

Indoor unit			Wired remote control	Description
OPERATION lamp (green)	TIMER lamp (orange)	ECONOMY lamp (green)		
●(1)	●(1)	◇	11	Serial communication error
●(1)	●(2)	◇	12	Wired remote control communication error
●(1)	●(5)	◇	15	Check run unfinished
●(2)	●(1)	◇	21	Unit number or Refrigerant circuit address setting error [Simultaneous Multi]
●(2)	●(2)	◇	22	Indoor unit capacity error
●(2)	●(3)	◇	23	Combination error
●(2)	●(4)	◇	24	• Connection unit number error (indoor slave unit) [Simultaneous Multi] • Connection unit number error (indoor unit or branch unit) [Flexible Multi]
●(2)	●(7)	◇	27	Master unit, slave unit set-up error [Simultaneous Multi]
●(3)	●(2)	◇	32	Indoor unit PCB model information error
●(3)	●(5)	◇	35	Manual auto switch error
●(4)	●(1)	◇	41	Inlet air temp. sensor error
●(4)	●(2)	◇	42	Indoor unit Heat Ex. Middle temp. sensor error
●(5)	●(1)	◇	51	Indoor unit fan motor error
●(5)	●(3)	◇	53	Drain pump error
●(5)	●(7)	◇	57	Damper error
●(5)	●(15)	◇	5U	Indoor unit error
●(6)	●(2)	◇	62	Outdoor unit main PCB model information error or communication error
●(6)	●(3)	◇	63	Inverter error
●(6)	●(4)	◇	64	Active filter error, PFC circuit error
●(6)	●(5)	◇	65	Trip terminal L error
●(6)	●(10)	◇	6A	Display PCB microcomputers communication error
●(7)	●(1)	◇	71	Discharge temp. sensor error

OPERATION lamp (green)	TIMER lamp (orange)	ECONOMY lamp (green)	Wired remote control	Description
●(7)	●(3)	◇	73	Outdoor unit Heat Ex. liquid temp. sensor error
●(7)	●(4)	◇	74	Outdoor temp. sensor error
●(7)	●(5)	◇	75	Suction Gas temp. sensor error
●(7)	●(6)	◇	76	• 2-way valve temp. sensor error • 3-way valve temp. sensor error
●(7)	●(7)	◇	77	Heat sink temp. sensor error
●(8)	●(2)	◇	82	• Sub-cool Heat Ex. gas inlet temp. sensor error • Sub-cool Heat Ex. gas outlet temp. sensor error
●(8)	●(3)	◇	83	Liquid pipe temp. sensor error
●(8)	●(4)	◇	84	Current sensor error
●(8)	●(6)	◇	86	• Discharge pressure sensor error • Suction pressure sensor error • High pressure switch error
●(9)	●(4)	◇	94	Trip detection
●(9)	●(5)	◇	95	Compressor rotor position detection error (permanent stop)
●(9)	●(7)	◇	97	Outdoor unit fan motor error
●(9)	●(9)	◇	99	4-way valve error
●(10)	●(1)	◇	A1	Discharge temp. error
●(10)	●(3)	◇	A3	Compressor temp. error
●(10)	●(4)	◇	A4	High pressure error
●(10)	●(5)	◇	A5	Low pressure error
●(13)	●(2)	◇	J2	Branch boxes error [Flexible Multi]

DECORATION PANEL  
UTG-UFYD-W

INDOOR UNIT  
AUYG18LVLB

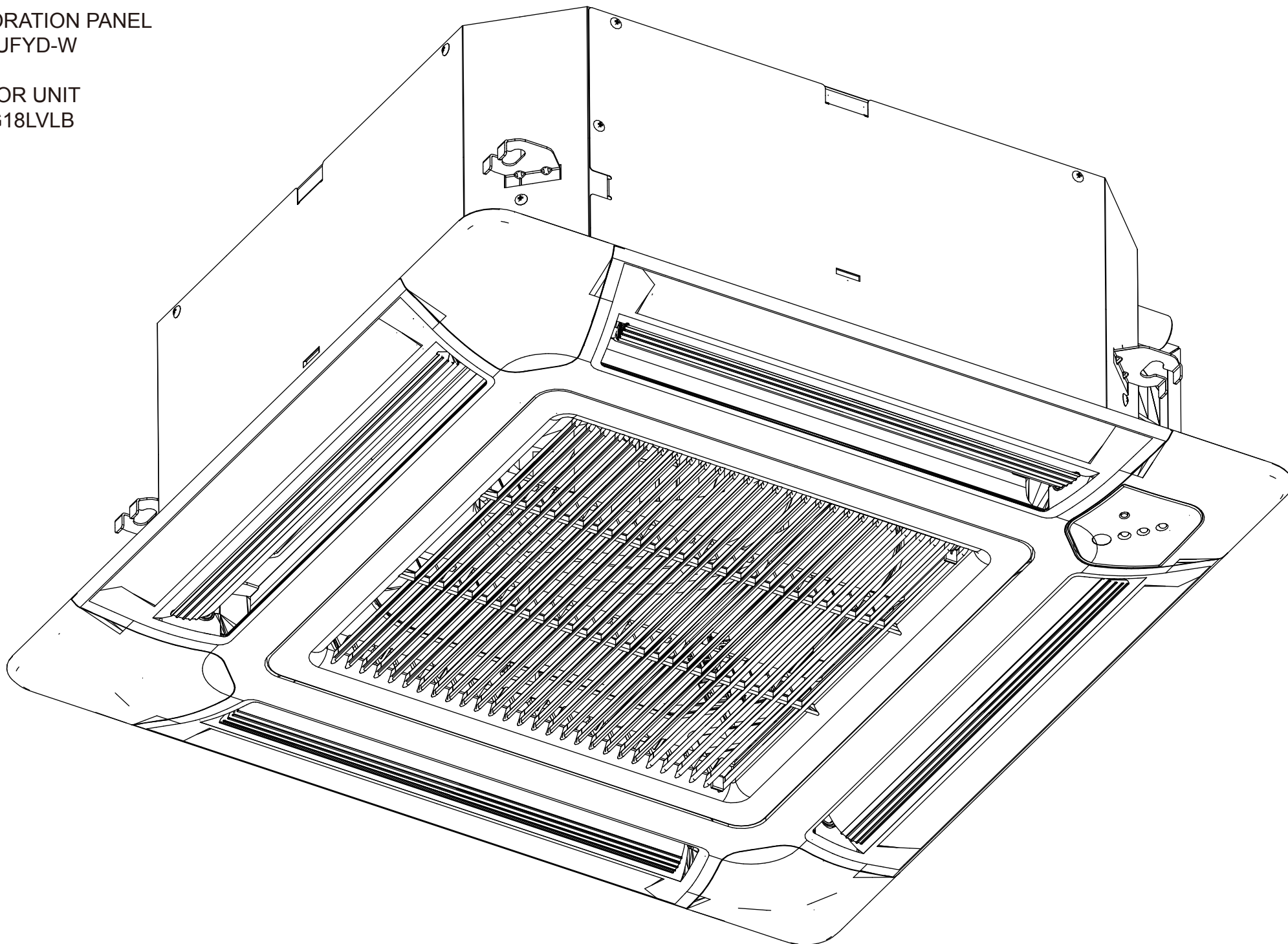

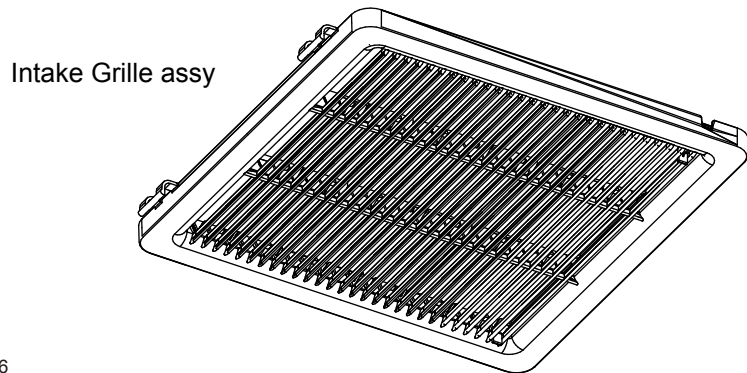
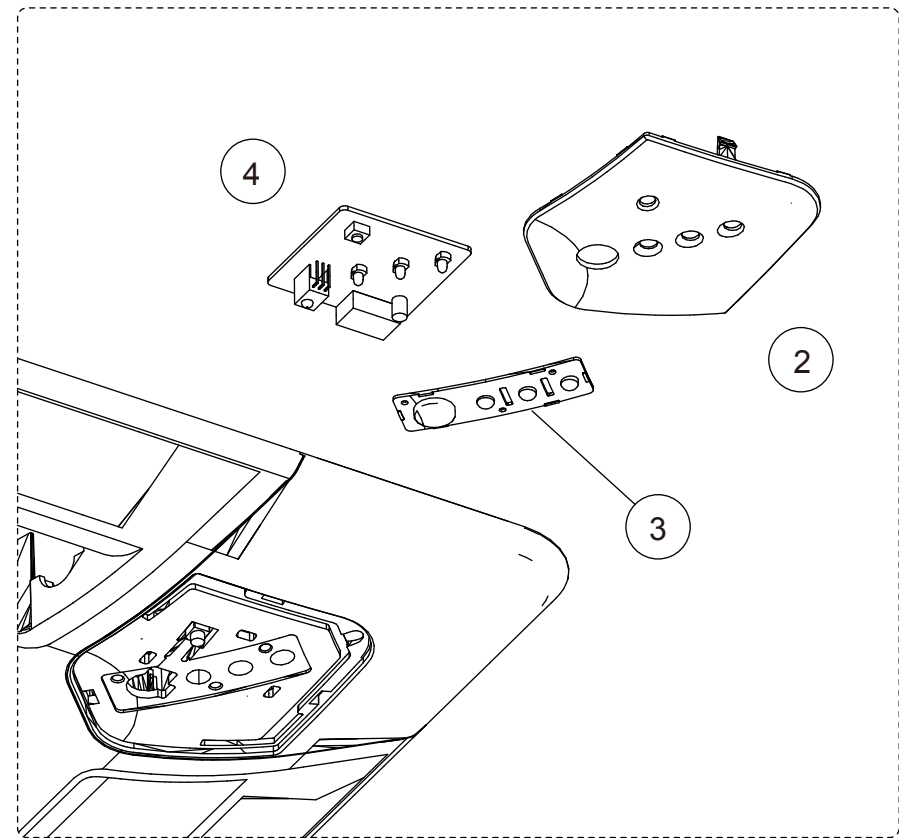
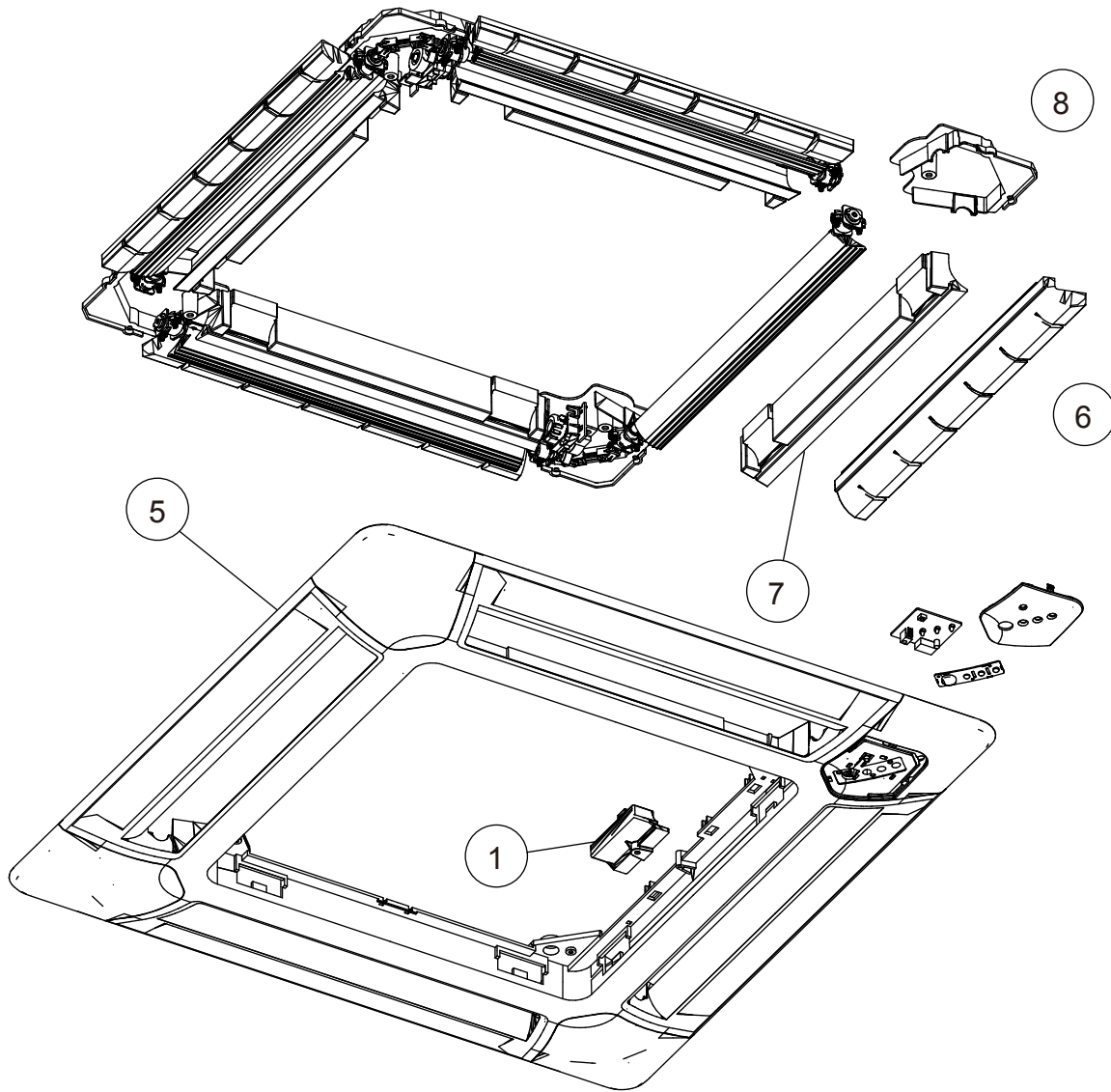

DECORATION PANEL  
UTG-UFYD-W

Ref.	Description	Part number
1	Connector cover	9375549015
2	Display panel	9375529123
3	Receiver window	9375547011
4	Indicator PCB	9707371031
5	Decoration panel	9375525040
6	Panel insulation A	9375526016
7	Panel insulation B	9375527013
8	Panel cover	9375530013

DECORATION PANEL  
 UTG-UFYD-W  
 Intake grille assy

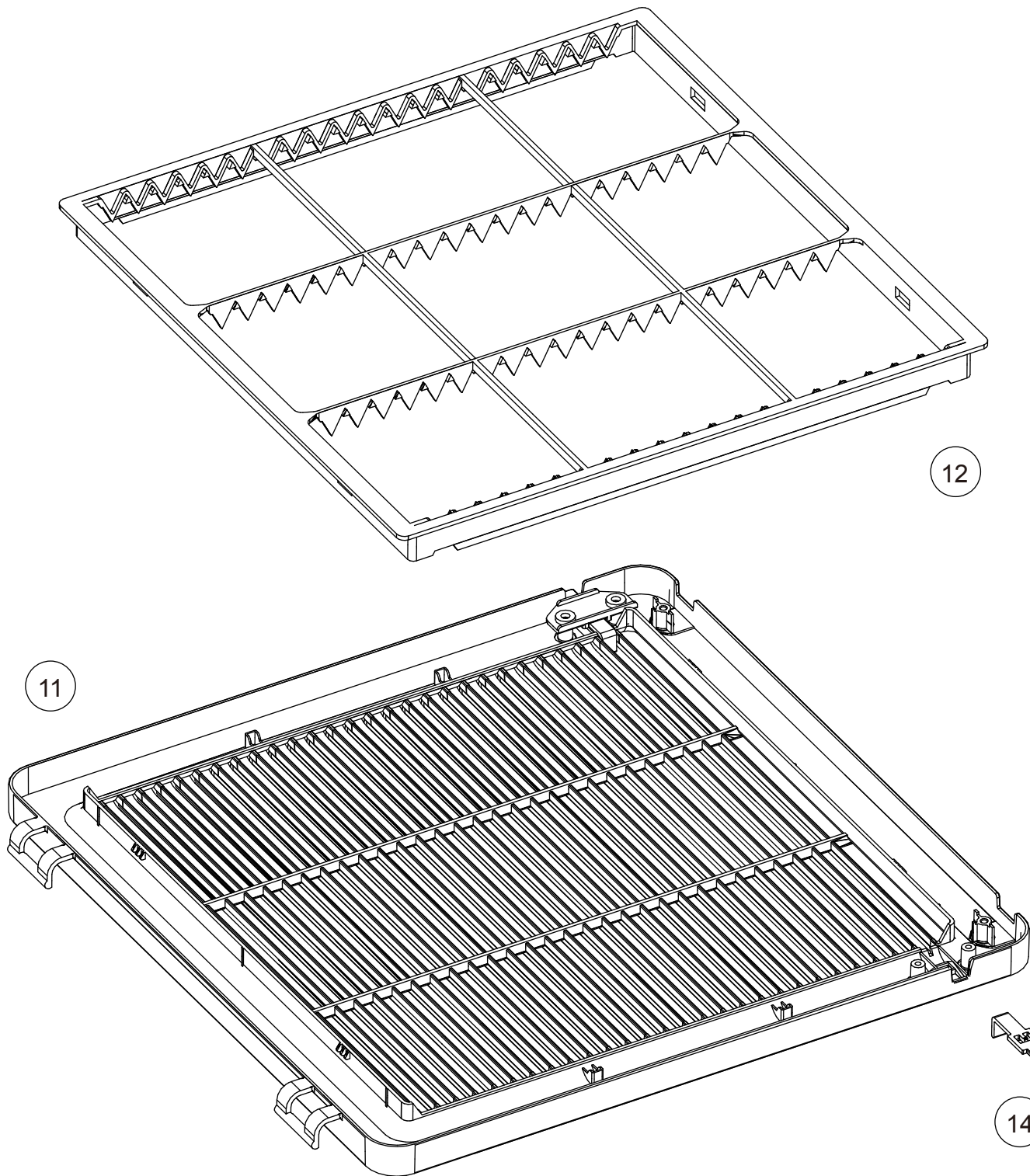

Ref.	Description	Part number
11	Intake grille	9375531027
12	Long life filter	9375533014
13	Hook bracket	9375546014
14	Grille hook	9375532024

DECORATION PANEL

UTG-UFYD-W

Flap total assy

Motor holder assy

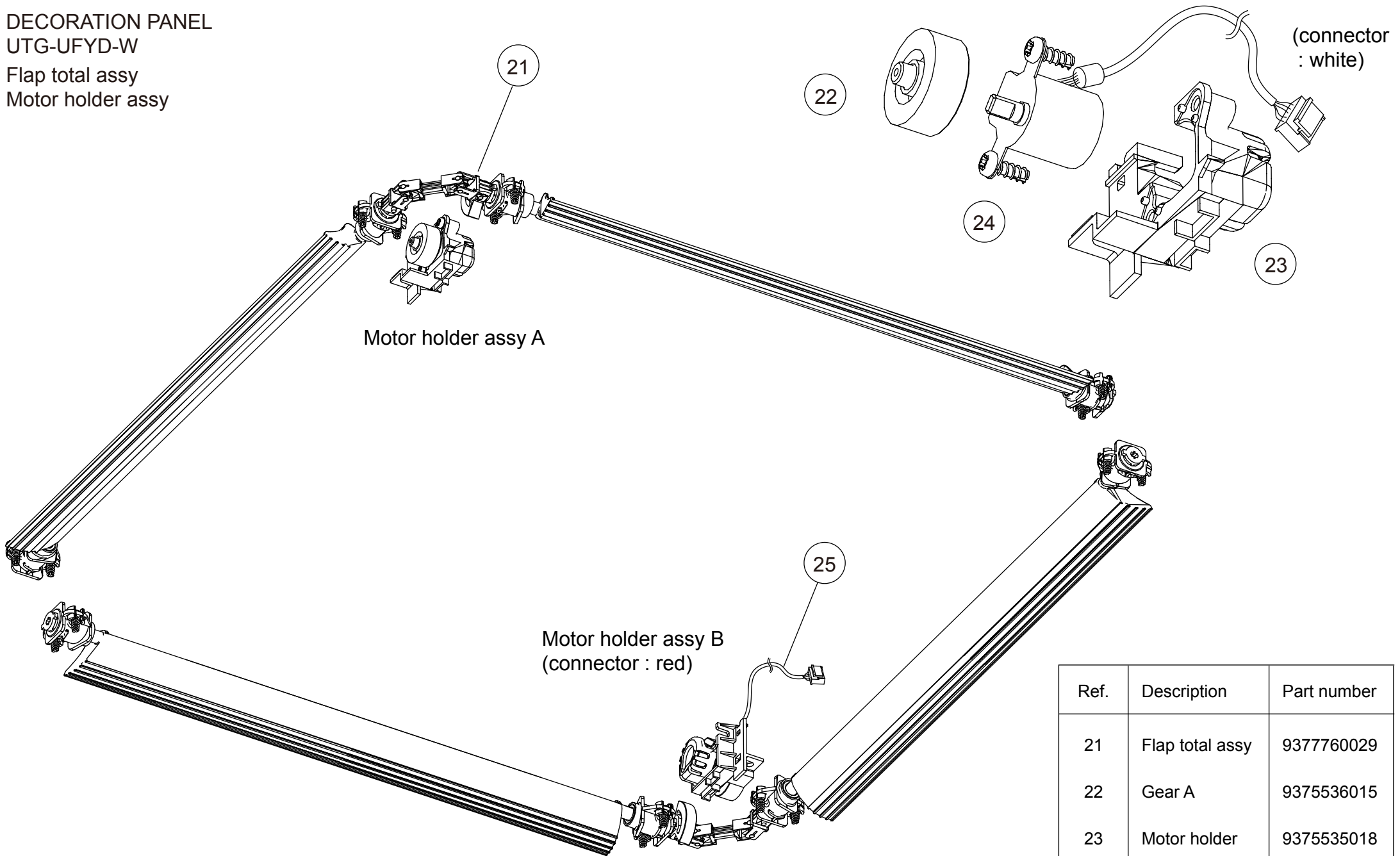

Ref.	Description	Part number
21	Flap total assy	9377760029
22	Gear A	9375536015
23	Motor holder	9375535018
24	Step motor	9900139070
25	Step motor	9900139087

INDOOR UNIT  
AUYG18LVLB

Control box cover

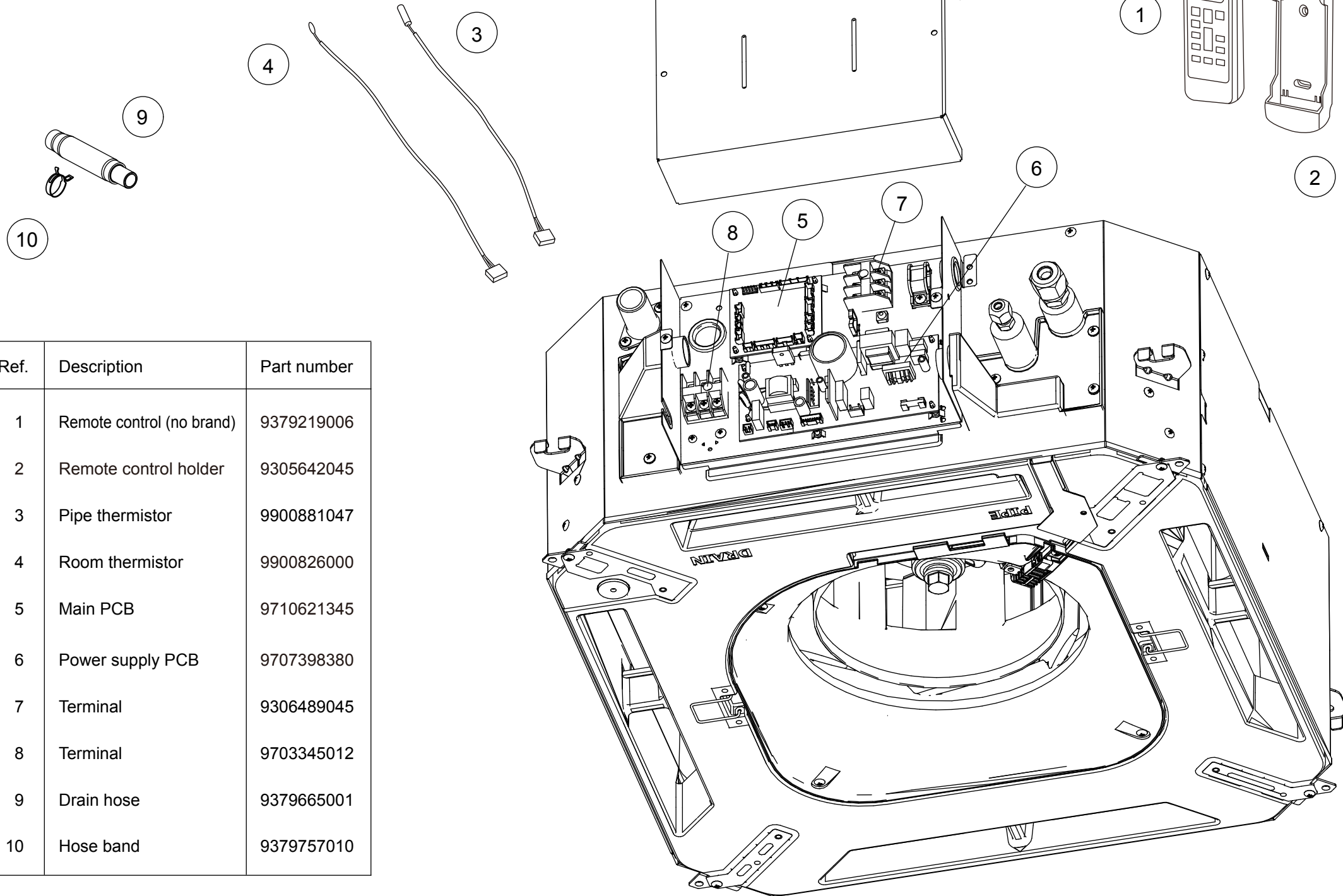

Ref.	Description	Part number
1	Remote control (no brand)	9379219006
2	Remote control holder	9305642045
3	Pipe thermistor	9900881047
4	Room thermistor	9900826000
5	Main PCB	9710621345
6	Power supply PCB	9707398380
7	Terminal	9306489045
8	Terminal	9703345012
9	Drain hose	9379665001
10	Hose band	9379757010

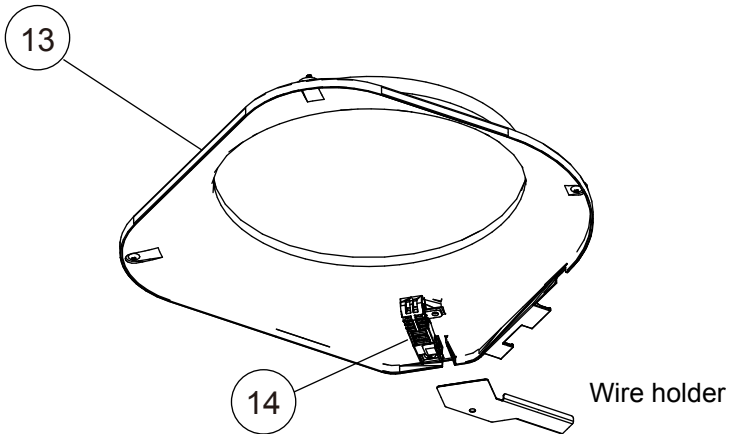
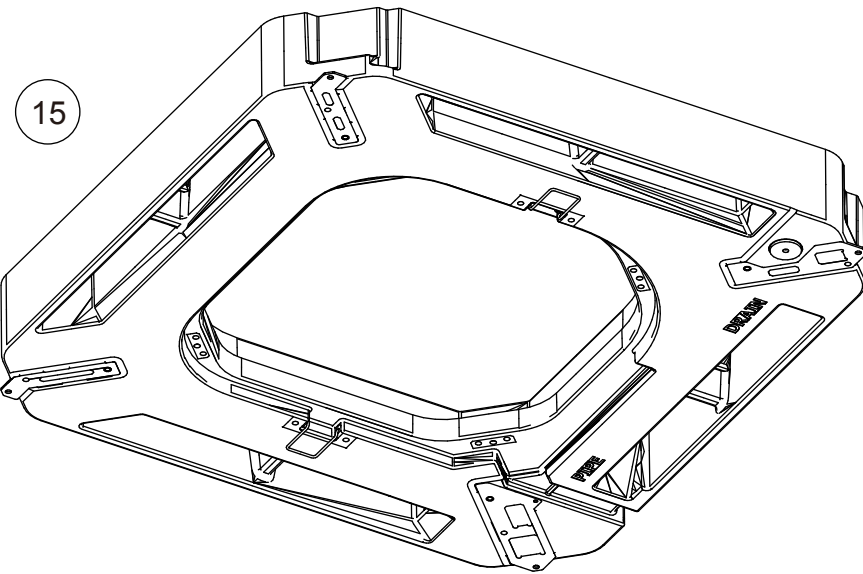
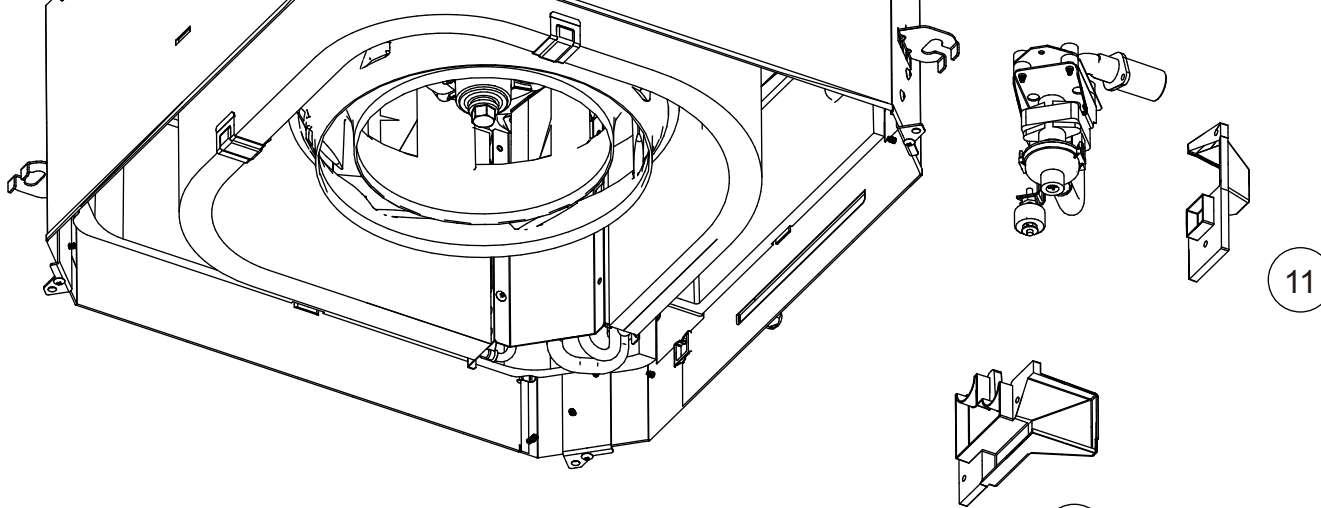

INDOOR UNIT  
AUYG18LVLB

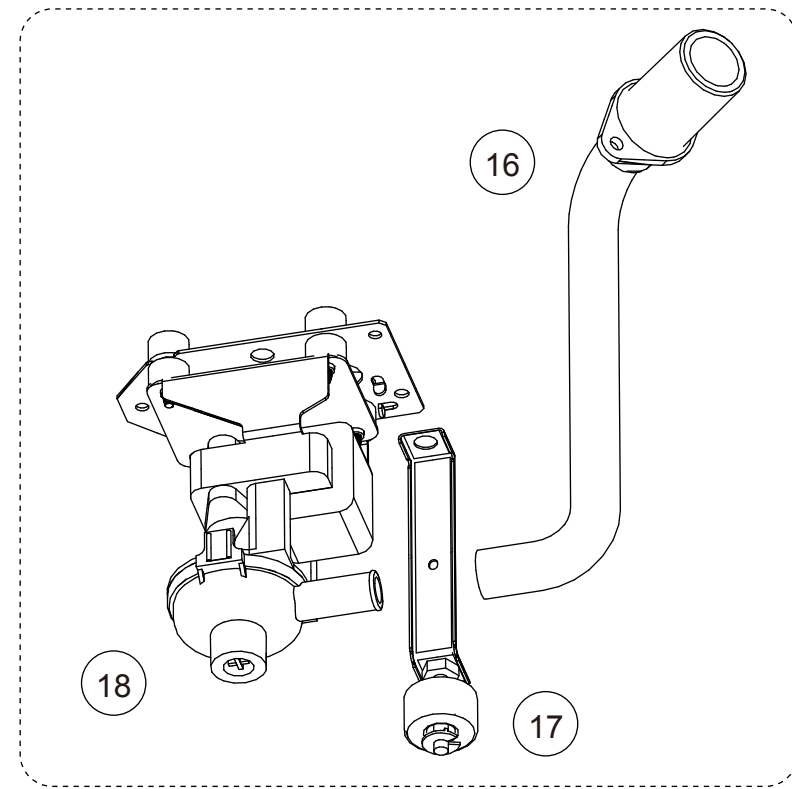

Ref.	Description	Part number
11	Wire cover	9375516017
12	Pipe cover	9375515010
13	Bellmouth	9375503017
14	Thermistor holder	9375477011
15	Drain pan sub assy	9377765024
16	Drain port sub assy	9377765017
17	Float switch sub assy	9375721039
18	Drain pump sub assy	9375717025



INDOOR UNIT  
 AUYG18LVLB

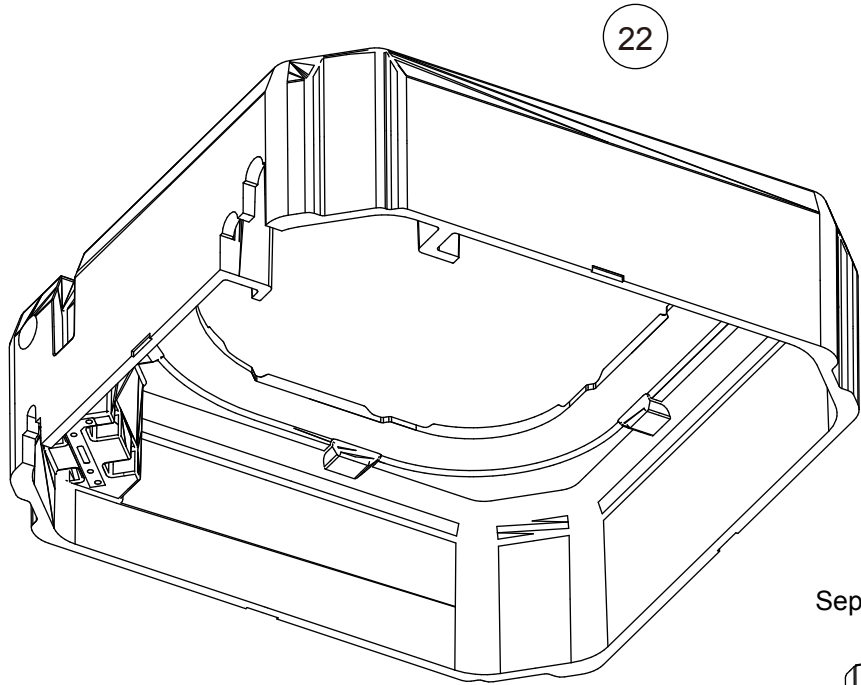

22

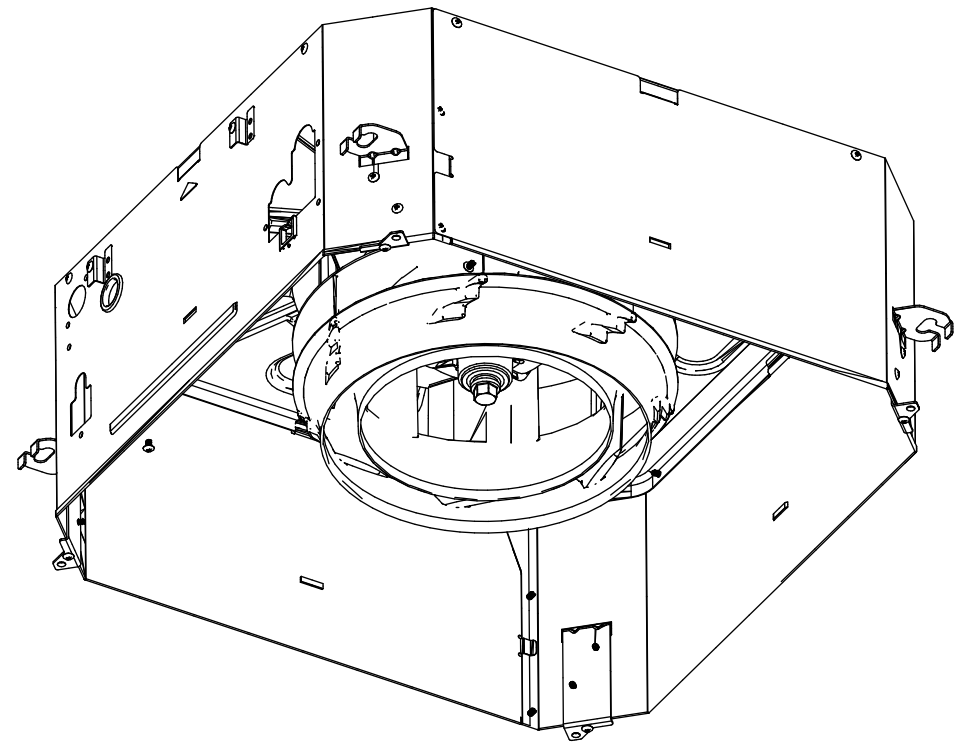

Separate wall

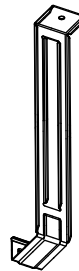
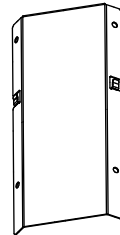

Evaporator  
 holder

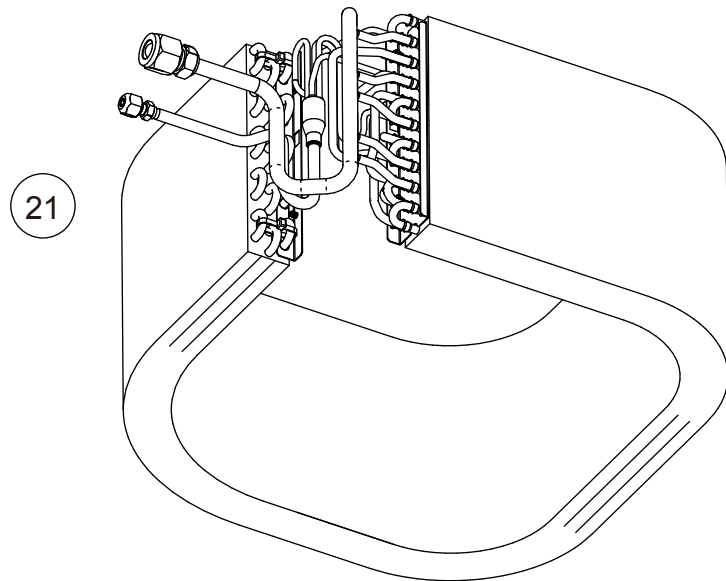
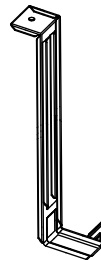

21

Ref.	Description	Part number
21	Evaporator total assy	9377914026
22	Insulation box sub assy	9377764065

Cabinet B sub assy

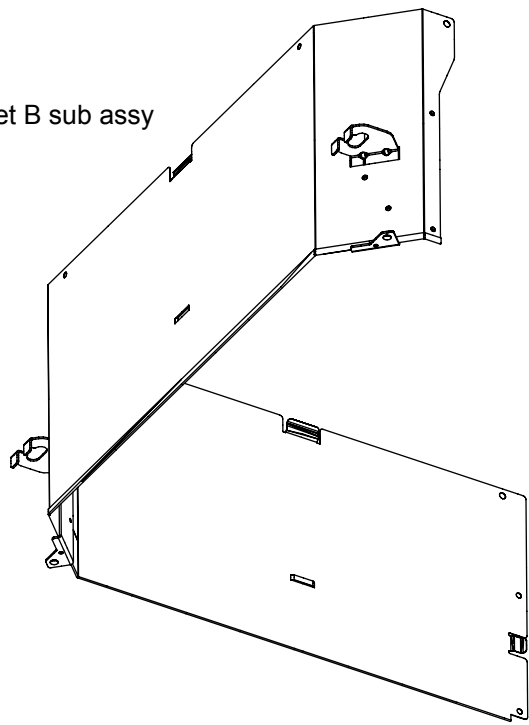

Top plate assy

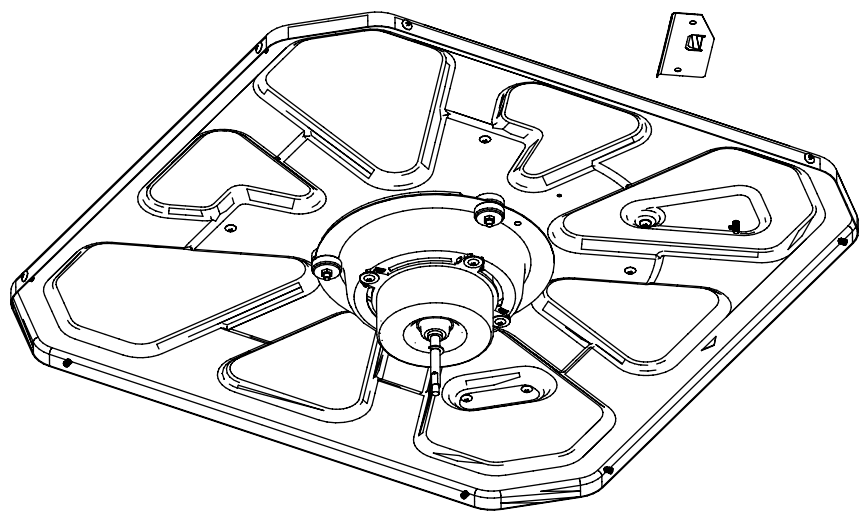

Motor wire holder



Cabinet A sub assy

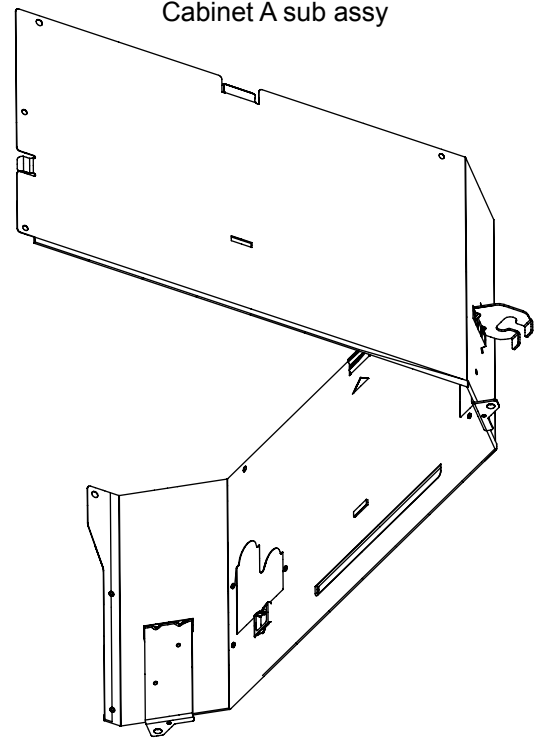

31

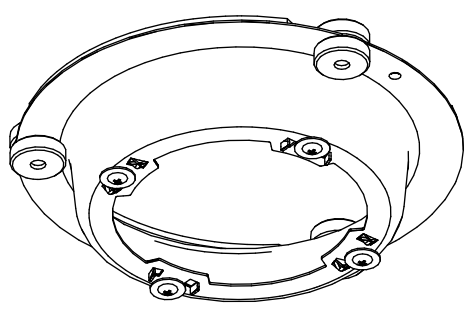

33

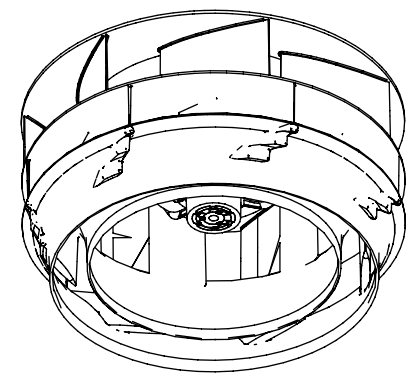

32

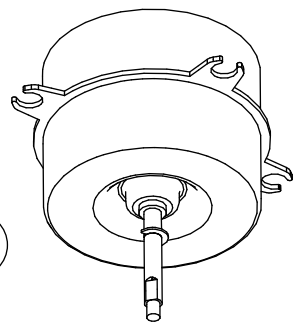

Turbo fan washer

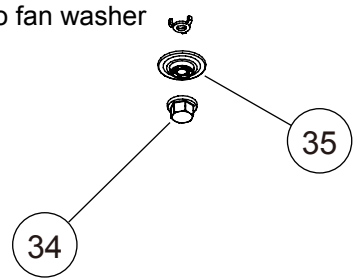

Ref.	Description	Part number
31	Fan motor sub assy	9375719012
32	Fan motor	9602436019
33	2 stage turbo fan assy	9375480011
34	Shaft cap	9377807014
35	Washer cover	9377811011

# PARTS

OUTDOOR UNIT  
AOYG18LBCB

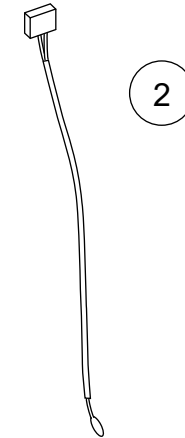
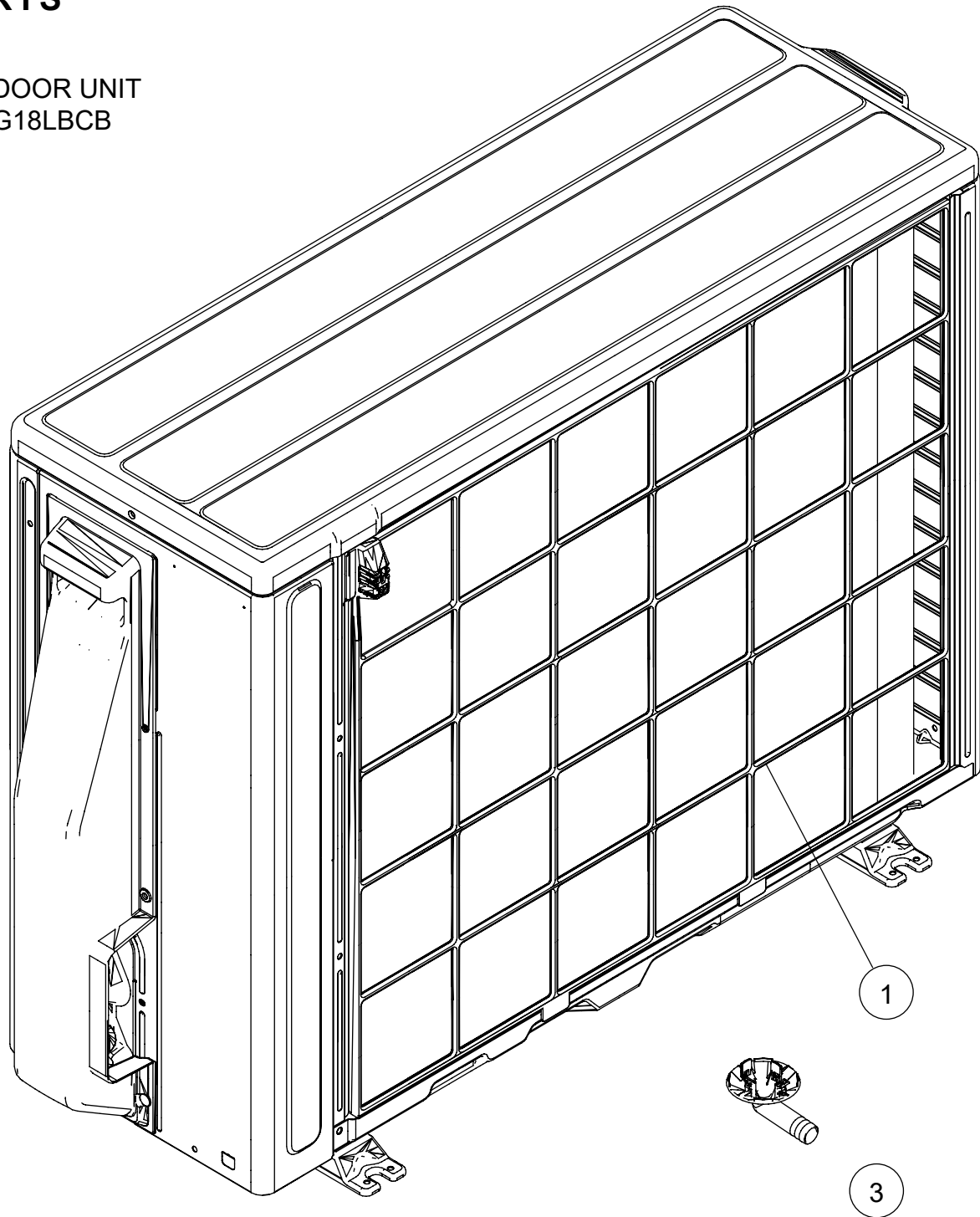

Ref.	Description	Part number
1	Protective net assy	9322811028
2	Outdoor thermistor	9900565060
3	Drain pipe	9322144003

OUTDOOR UNIT  
AOYG18LBCB

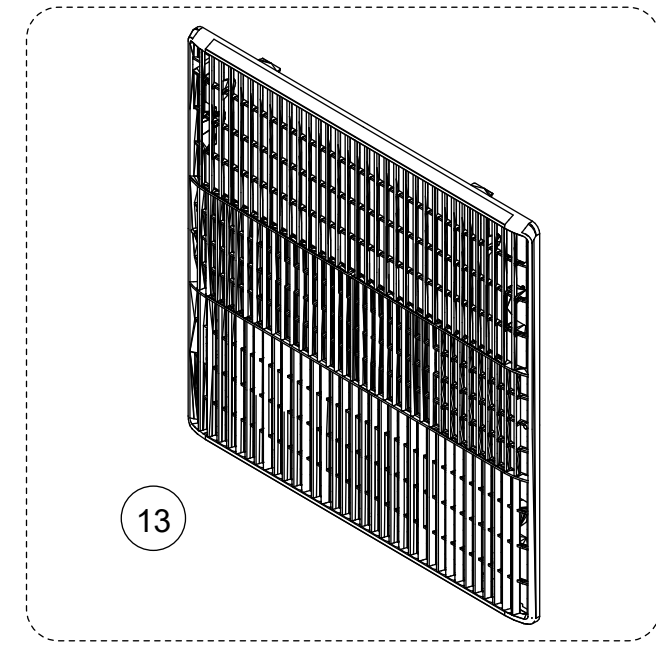
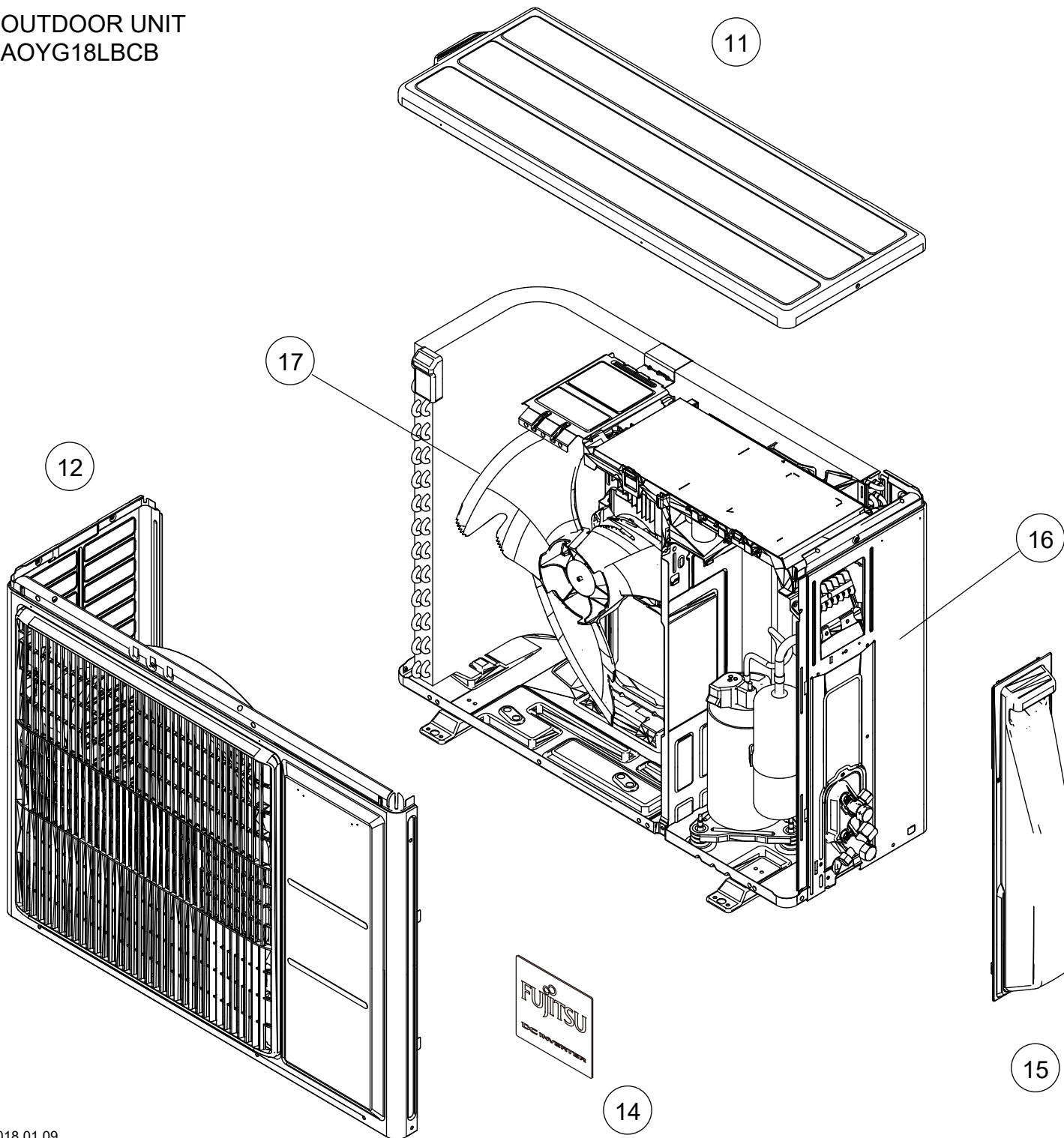

Ref.	Description	Part number
11	Top panel assy	9322556066
12	Front panel assy	9322555021
13	Blow grille	9322149008
14	Emblem	9319151007
15	Switch cover assy	9322570024
16	Cabinet right assy	9322552099
17	Propeller fan	9322150004

OUTDOOR UNIT  
AOYG18LBCB

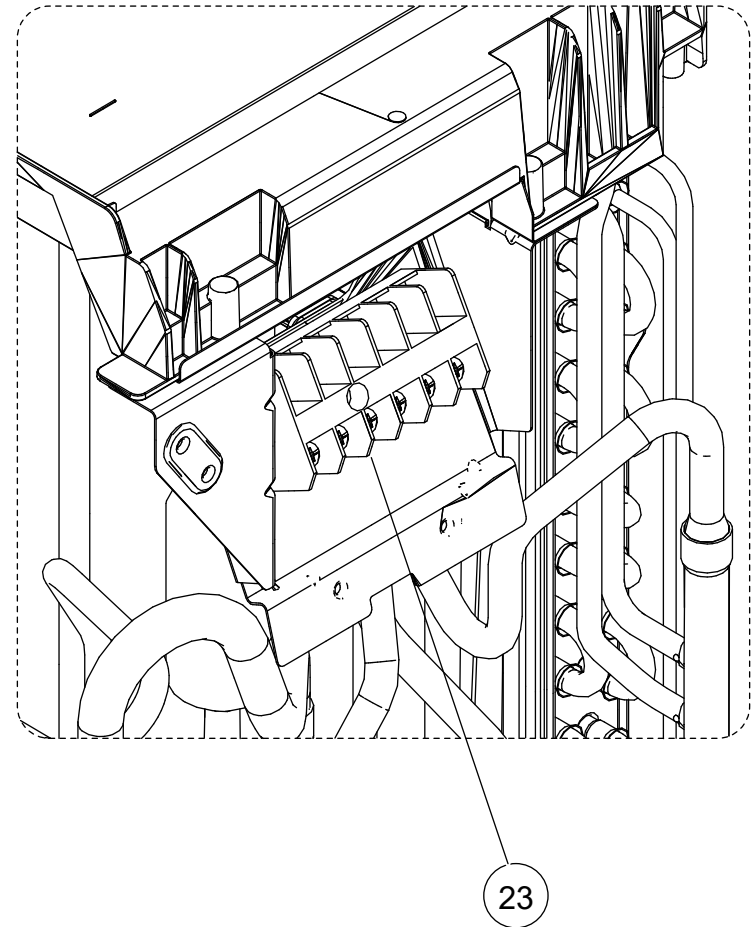
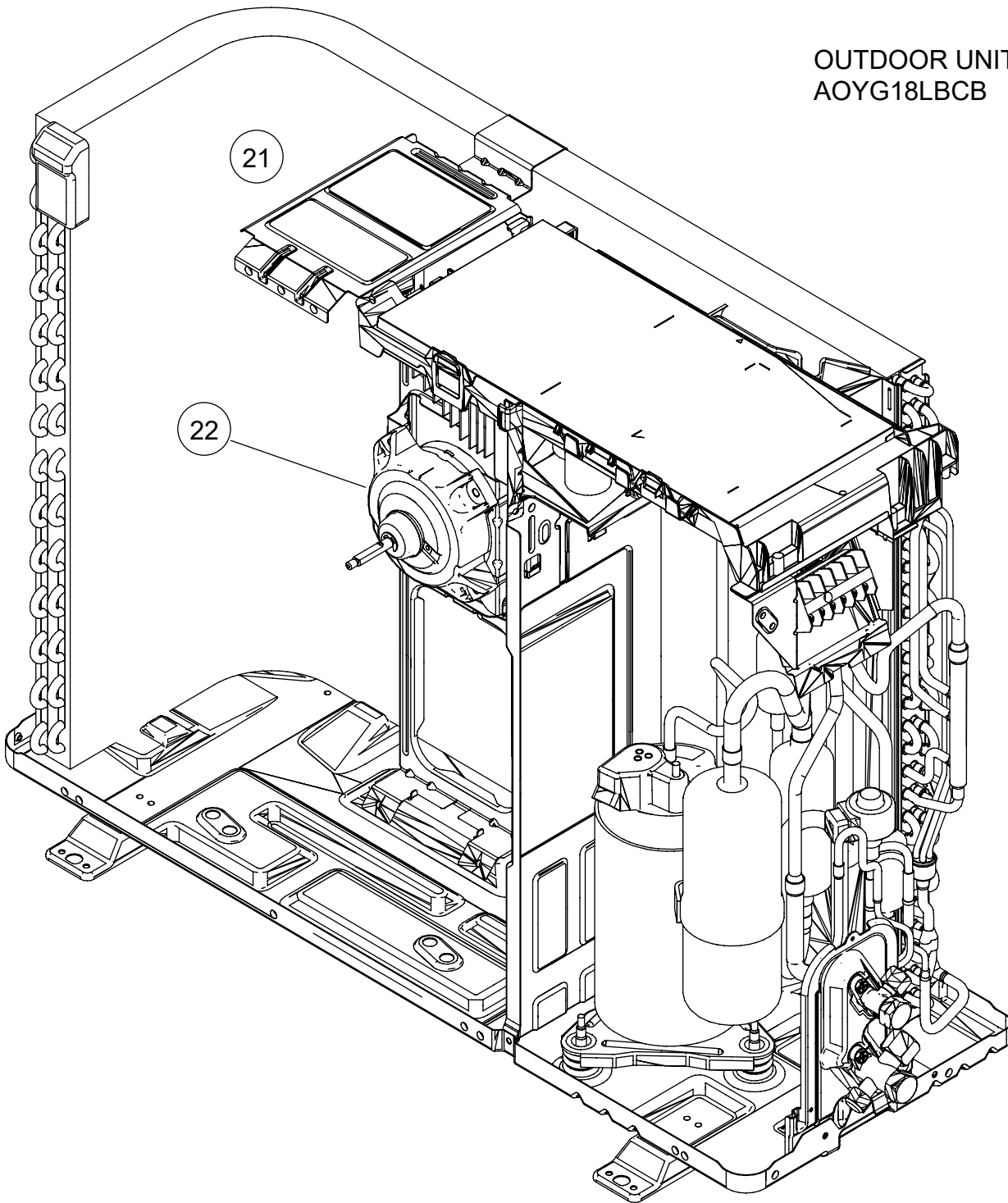

Ref.	Description	Part number
21	Motor bracket assy	9322553027
22	Brushless motor	9603601003
23	Terminal	9900435028

OUTDOOR UNIT  
AOYG18LBCB

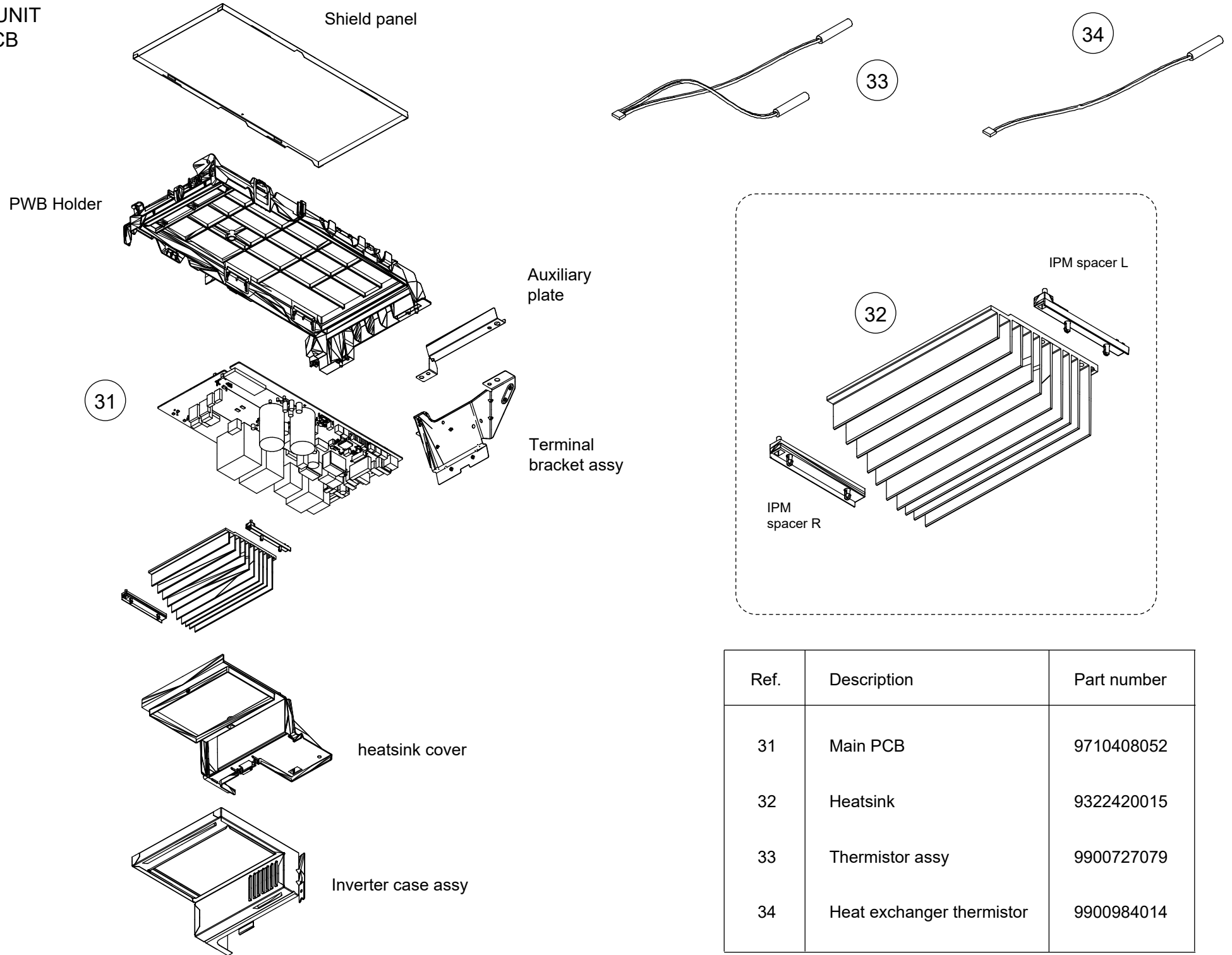

Ref.	Description	Part number
31	Main PCB	9710408052
32	Heatsink	9322420015
33	Thermistor assy	9900727079
34	Heat exchanger thermistor	9900984014

OUTDOOR UNIT  
AOYG18LBCB

Ref.	Description	Part number
41	Condenser total assy	9317089616
-	S-insulator B	9322500007
-	S-insulator F	9322847003
-	S-insulator H	9322501004
-	S-insulator V	9323045002

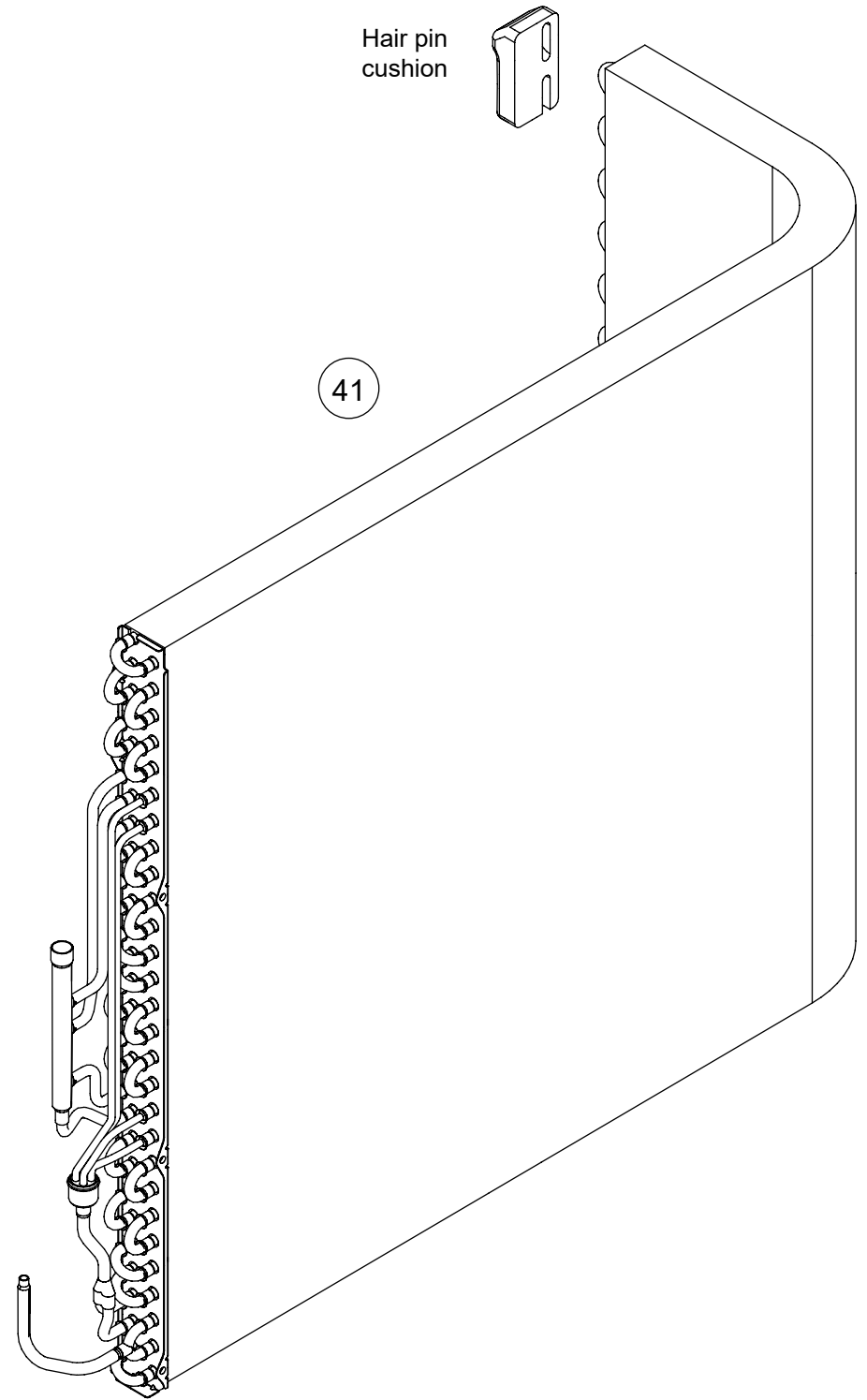
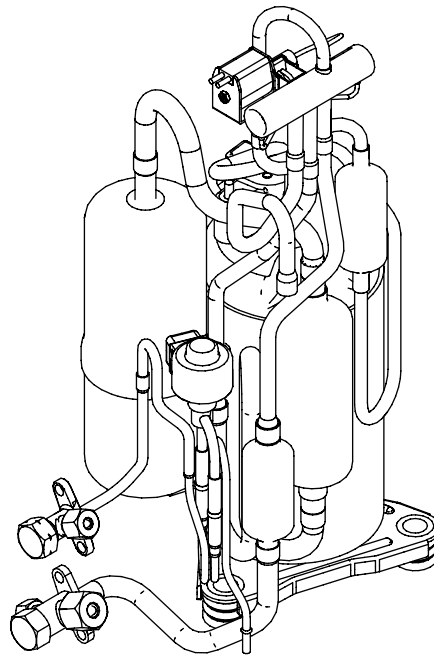

OUTDOOR UNIT  
AOYG18LBCB

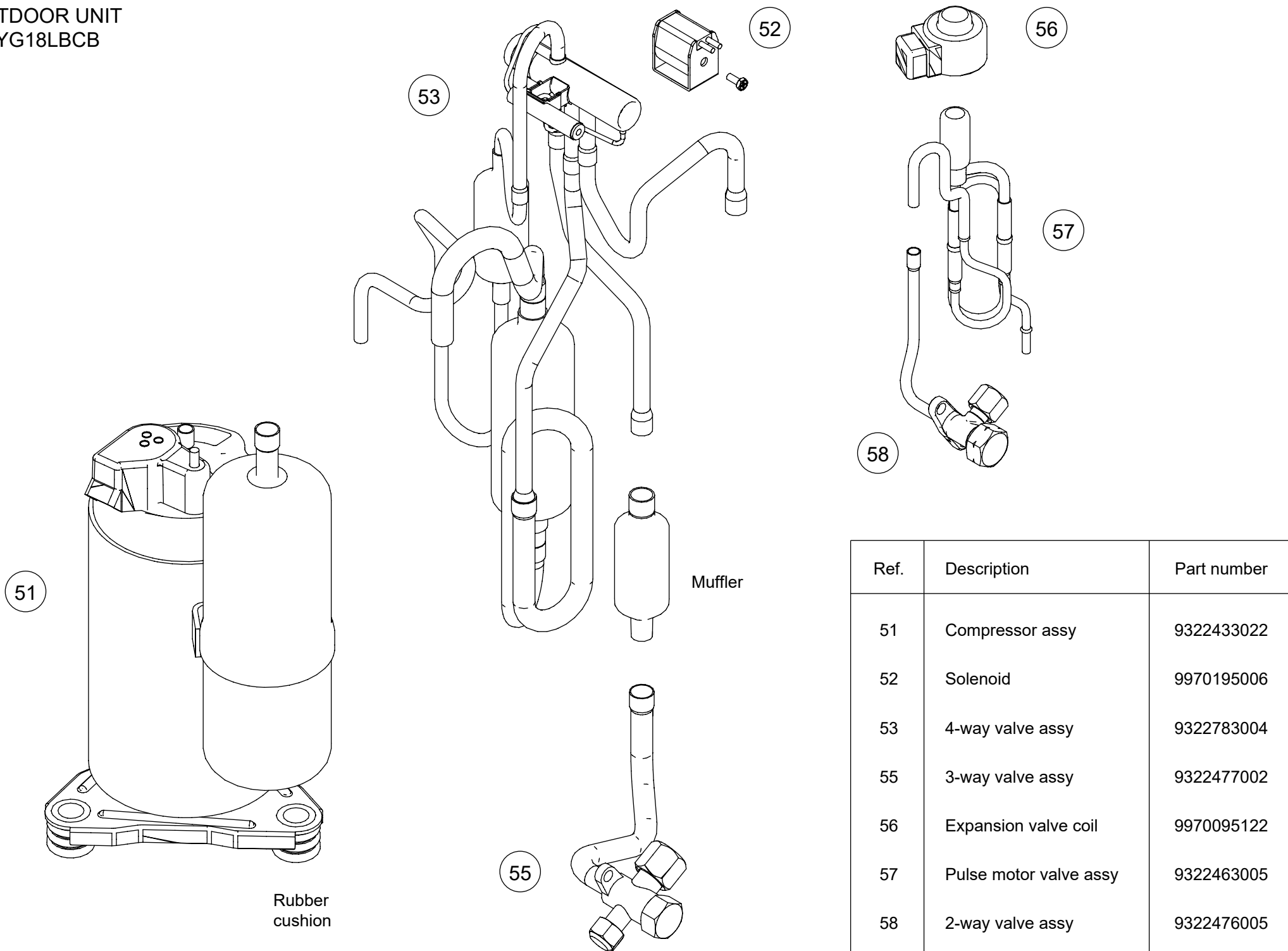









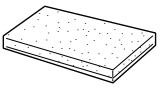

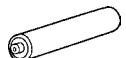
Ref.	Description	Part number
51	Compressor assy	9322433022
52	Solenoid	9970195006
53	4-way valve assy	9322783004
55	3-way valve assy	9322477002
56	Expansion valve coil	9970095122
57	Pulse motor valve assy	9322463005
58	2-way valve assy	9322476005



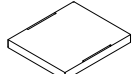

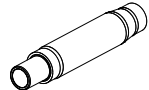

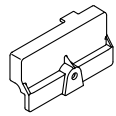

# ACCESSORIES

## INDOOR UNIT AUYG18LVLB

Name and Shape	Q'ty	Name and Shape	Q'ty
Coupler heat insulation (Large)  For indoor side pipe joint (gas pipe)	1	Drain hose insulation  For installing drain pipe	1
Coupler heat insulation (Small)  For indoor side pipe joint (liquid pipe)	1	Remote control  Battery 	1
Special nut A (Large flange)  For installing indoor unit	4	Remote control holder 	1
Special nut B (Small flange)  For installing indoor unit	4	Tapping screw (M3 × 12mm)  Mounting the remote control holder	2
Template (Carton top)  For ceiling openings cutting Also used as packing	1	Cable tie  For electrical wiring	2
Drain hose  For installing drain pipe	1	Wire clasper  For electrical wiring	1
Hose Band  For installing drain hose	1		

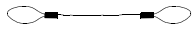
## DECORATION PANEL UTG-UFYD-W

Name and Shape	Q'ty	Name and Shape	Q'ty
Connector cover  For covering connector	1	Tapping Screw (M5 × 12 mm)  Mounting decoration panel	4
Tapping Screw (M4 × 12 mm)  Mounting connector cover	1	L angle  Mounting the Hook Wire to the decoration panel	2
Hook wire  Suspending the decoration panel	2	Screw [pitch small] (M4 × 10 mm)  Mounting the Hook wire (for metals)	2
Screw [pitch large] (M4 × 10 mm)  Mounting the L angle and Hook wire (for resins)	4		

## OUTDOOR UNIT AOYG18LBCB

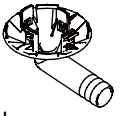
Name and Shape	Q'ty
Drain pipe 9322144003  For drain piping work	1

1801G4675