

**SPLIT TYPE
ROOM AIR CONDITIONER
WALL MOUNTED^{type}
INVERTER**

SERVICE INSTRUCTION



Models	Indoor unit	Outdoor unit
	AS*G18KLCA	AO*G18KLTA
	AS*G24KLCA	AO*G24KLTA

CONTENTS

1. DESCRIPTION OF EACH CONTROL OPERATION

1. COOLING OPERATION.....	01-01
2. HEATING OPERATION.....	01-02
3. DRY OPERATION.....	01-03
4. AUTO CHANGEOVER OPERATION.....	01-04
5. INDOOR FAN CONTROL.....	01-05
6. OUTDOOR FAN CONTROL.....	01-07
7. LOUVER CONTROL.....	01-08
8. COMPRESSOR CONTROL.....	01-09
9. TIMER OPERATION CONTROL.....	01-10
10. ELECTRONIC EXPANSION VALVE CONTROL.....	01-13
11. TEST OPERATION CONTROL.....	01-13
12. PREVENT TO RESTART FOR 3 MINUTES (3 MINUTES ST).....	01-13
13. FOUR-WAY VALVE EXTENSION SELECT.....	01-13
14. AUTO RESTART.....	01-14
15. MANUAL AUTO OPERATION (Indoor unit body operation).....	01-14
16. FORCED COOLING OPERATION.....	01-14
17. COMPRESSOR PREHEATING.....	01-15
18. ECONOMY OPERATION.....	01-15
19. POWERFUL OPERATION.....	01-16
20. DEFROST OPERATION CONTROL.....	01-17
21. OFF DEFROST OPERATION CONTROL.....	01-19
22. VARIOUS PROTECTIONS.....	01-20

2. TROUBLE SHOOTING

2-1 ERROR DISPLAY.....	02-01
2-1-1 INDOOR UNIT AND WIRED REMOTE CONTROLLER DISPLAY.....	02-01
2-1-2 WIRED REMOTE CONTROLLER DISPLAY (OPTION).....	02-03
2-2 TROUBLE SHOOTING WITH ERROR CODE.....	02-04
2-3 TROUBLE SHOOTING WITH NO ERROR CODE.....	02-31
2-4 SERVICE PARTS INFORMATION.....	02-36

3. APPENDING DATA

3-1 FUNCTION SETTING.....	03-01
3-1-1 INDOOR UNIT.....	03-01

WALL MOUNTED type INVERTER

1 . DESCRIPTION OF EACH CONTROL OPERATION

1. COOLING OPERATION

A sensor (room temperature thermistor) built in the indoor unit body will usually perceive difference or variation between a set temperature and present room temperature, and controls the operation frequency of the compressor.

- * If the room temperature is 6°C higher than a set temperature, the compressor operation frequency will attain to maximum performance.
- * If the room temperature is some degrees lower than a set temperature, the compressor will be stopped.
- * When the room temperature is between +6°C to -1°C of the setting temperature, the compressor frequency is controlled within the range shown in Table1. However, the maximum frequency is limited in the range shown in Fig.1 based on the indoor fan mode and the outdoor temperature.

(Table 1 : Compressor frequency range)

	Minimum frequency	Maximum frequency II	Maximum frequency I
AO*G18KLTA	8rps	74rps	94rps
AO*G24KLTA	10rps	68rps	102rps

When the compressor operates for 30 minutes continuously at over the maximum frequency II, the maximum frequency is changed from Maximum Frequency I to Maximum Frequency II.

(Fig.1 : Outdoor temperature zone)

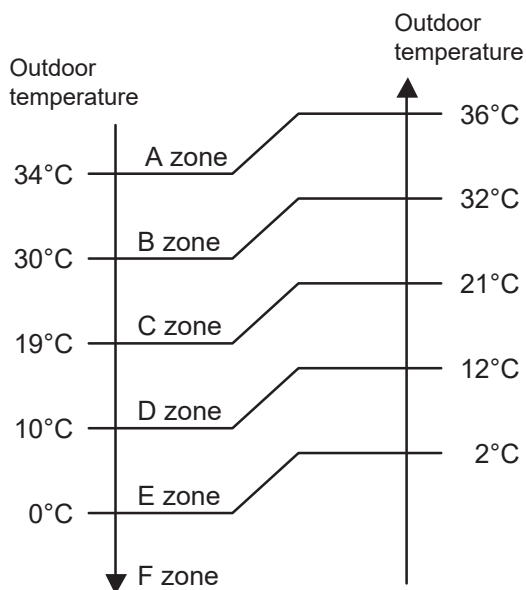

(Table 2 : Limit of maximum speed based on outdoor temperature)

	Outdoor temp. zone	Indoor fan mode			
		Hi	Me	Lo	Quiet
AO*G18KLTA	A zone	94rps	54rps	46rps	30rps
	B zone	94rps	54rps	46rps	30rps
	C zone	80rps	54rps	46rps	30rps
	D zone	80rps	54rps	46rps	30rps
	E zone	80rps	54rps	46rps	30rps
	F zone	80rps	54rps	46rps	30rps
AO*G24KLTA	A zone	102rps	58rps	46rps	30rps
	B zone	102rps	58rps	46rps	30rps
	C zone	80rps	58rps	46rps	30rps
	D zone	80rps	58rps	46rps	30rps
	E zone	80rps	58rps	46rps	30rps
	F zone	80rps	58rps	46rps	30rps

2. HEATING OPERATION

A sensor (room temperature thermistor) built in the indoor unit body will usually perceive difference or variation between a set temperature and present room temperature, and controls the operation frequency of the compressor.

* If the room temperature is lower by 6°C than a set temperature, the compressor operation frequency will attain to maximum performance.

* If the room temperature is some degrees higher than a set temperature, the compressor will be stopped.

* When the room temperature is between +1°C to -6°C of the setting temperature, the compressor frequency is controlled within the range shown in Table 3.

(Table 3 : Compressor frequency range)

	Minimum frequency	Maximum frequency
AO*G18KLTA	8rps	102rps
AO*G24KLTA	10rps	130rps

3. DRY OPERATION

The compressor frequency shall change according to the temperature, set temperature, and room temperature variation which the room temperature sensor of the indoor unit body has detected as shown in the Table 4.

(Table 4 : Compressor frequency in Dry mode)

	Operating frequency	
	18KLTA	24KLTA
X zone	30rps	30rps
J zone	16rps	16ps
Y zone	0rps	0rps

(Fig.2 : Compressor control based on room temperature)

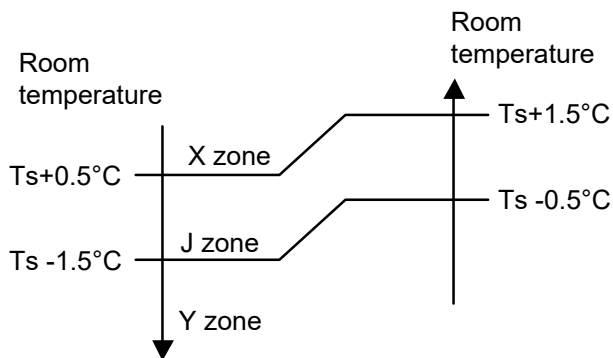

4. AUTO CHANGEOVER OPERATION

When the air conditioner is set to the AUTO mode by remote control, operation starts in the optimum mode from among the Heating, Cooling, and Monitoring modes. During operation, the optimum mode is automatically switched in accordance with temperature changes. The temperature can be set between 18°C and 30°C in 1°C steps.

(Fig. 3 : Operation flow chart in Auto changeover)

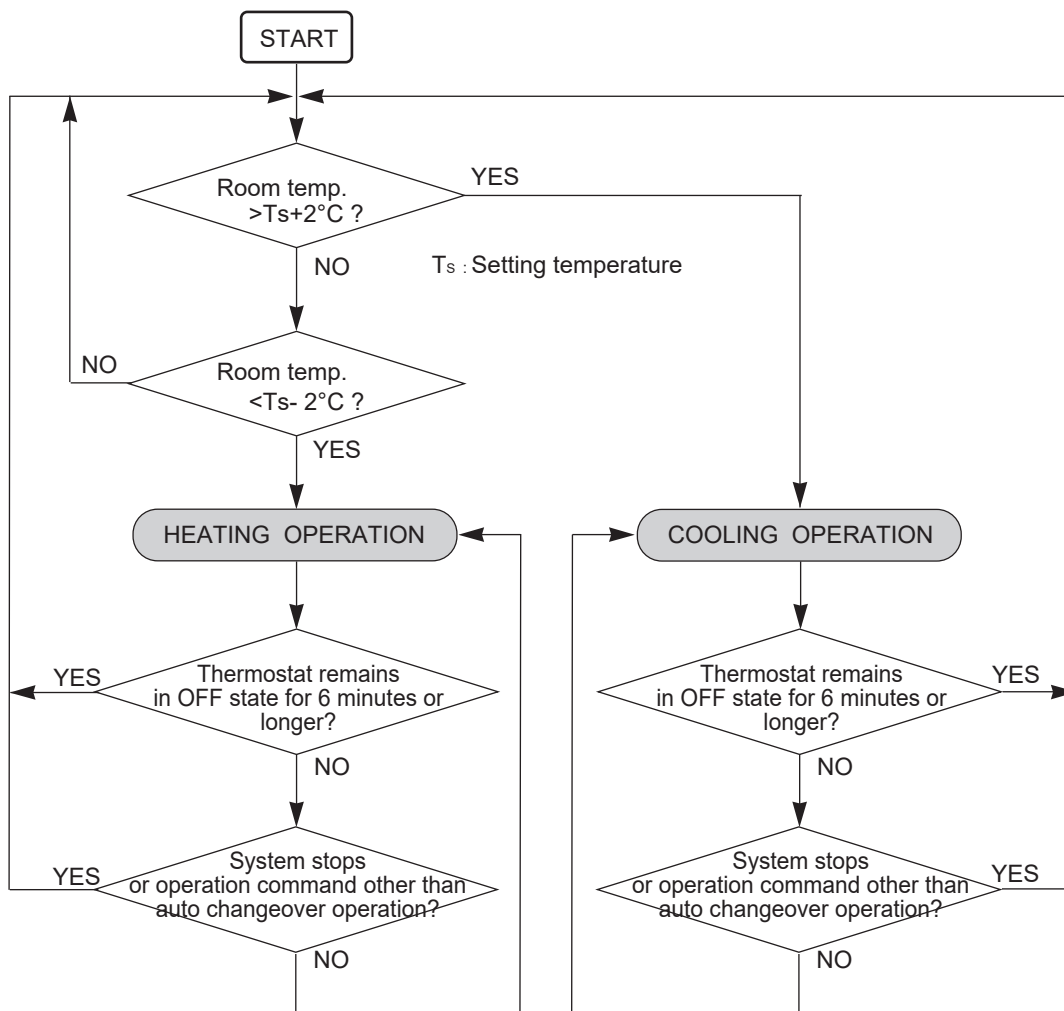

5. INDOOR FAN CONTROL

1. Fan speed

(Table 5 : Indoor fan speed)

Operation mode	Air flow mode	Speed (rpm)	
		AS*G18KLCA	AS*G24KLCA
Heating	Powerful	1560	1560
	Hi	1410	1480
	Me+	1330	1330
	Me	1190	1190
	Lo	1050	1040
	Quiet	910	920
	Cool air prevention	640	640
	S-Lo	500	500
Cooling/ Fan	Powerful	1460	1560
	Hi	1250	1480
	Me	1150	1270
	Lo	1010	1030
	Quiet	870	870
	Soft Quiet	640	640
Dry		X zone: 870 J zone: 670	X zone: 870 J zone: 730

*Note, during Economy operation and operation mode is Fan, air flow is 1 step downs.
(Hi > Me, Me > Lo, Lo > Quiet, Quiet > Soft Quiet)

2. FAN OPERATION

The airflow can be switched in 5 steps such as Auto, Quiet, Lo, Me, Hi, while the indoor fan only runs. When fan mode is set at [Auto], it operates on [Me] fan Speed.

3. COOLING OPERATION

Switch the airflow [Auto], and the indoor fan motor will run according to a room temperature, as shown in Fig4.

On the other hand, if switched in [Hi]~[Quiet], the indoor motor will run at a constant airflow of [Cool] operation modes Quiet, Lo, Me, Hi, as shown in Table 5.

(Fig.4 : Airflow change - over (Cooling : Auto))

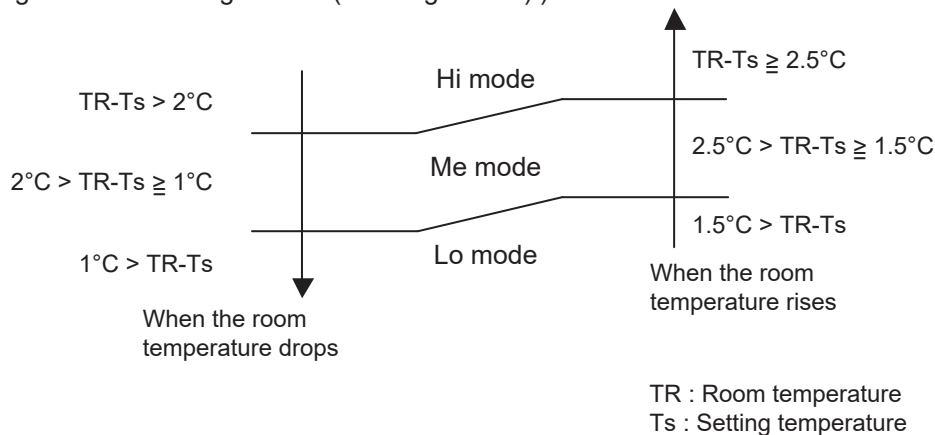

4. DRY OPERATION

Refer to the Table 5.

During the dry mode operation, the fan speed setting can not be changed.

6. OUTDOOR FAN CONTROL

1. Outdoor Fan Motor

Following table shows the type of the outdoor fan motor. The control method is different between AC motor and DC motor.

(Table 7 : Type of Motor)

AC Motor	DC Motor
	○

2. Fan Speed

(Table 8 : Outdoor fan speed)

	Zone ※	Cooling	Heating	Dry
18KLTA	Y	990/ 920/ 810/ 670/ 570/ 520	1120/ 870/ 710/ 660/ 500	990/ 920/ 810/ 670/ 570/ 520
	Z	630/ 610/ 450/ 310/ 200		630/ 610/ 450/ 310/ 200
	F	300/ 270/ 240/ 220/ 200		300/ 270/ 240/ 220/ 200
	G	280/ 250/ 220/ 200		280/ 250/ 220/ 200
24KLTA	Y	1050/ 1030/ 860/ 690/ 550/ 440/ 400	1100/ 850/ 680/ 570/ 510/ 470/ 420	1050/ 1030/ 860/ 690/ 550/ 440/ 400
	Z	850/ 770/ 630/ 440/ 320		850/ 770/ 630/ 440/ 320
	F	320/ 270		320/ 270
	G	270/230		270/ 230

※ Refer to Fig.8

(Fig.8 : Outside air temperature zone selection)

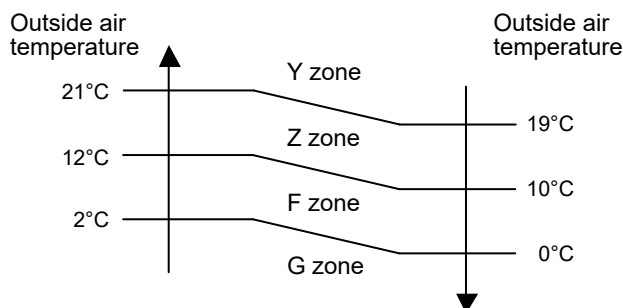

* The outdoor fan speed mentioned above depends on the compressor frequency, outdoor heat exchanger and outside temperature.

(When the compressor frequency increases, the outdoor fan speed also changes to the higher speed. When the compressor frequency decreases, the outdoor fan speed also changes to the lower speed.)

* After the defrost control is operated on the heating mode, the fan speed keeps at the higher speed as table9 without relating to the compressor frequency.

(Table 9 : Outdoor fan speed after the defrost)

AO*G18KLTA	1120rpm
AO*G24KLTA	1100rpm

7. LOUVER CONTROL

1. VERTICAL LOUVER CONTROL

(Function Range)

Each time the button is pressed, the air direction range will change as follow:

① ↔ ② ↔ ③ ↔ ④ ↔ ⑤ ↔ ⑥

Types of Air flow Direction Setting:

ALL MODE : ① ~ ⑥

The Remote Controller's display does not change.

Fig.9 : Air Direction Range

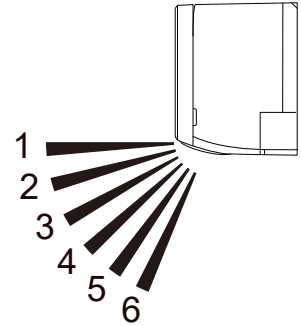

- Use the air direction adjustments within the ranges shown above.
- The vertical airflow direction is set automatically as shown, in accordance with the type of operation selected.
 - Cooling / Dry mode : Horizontal flow ①
 - Heating mode : Downward flow ⑤
- During AUTO mode operation, for the first a few minutes after beginning operation, air-flow will be horizontal ①; the air direction cannot be adjusted during this period. The air flow direction setting will temporarily become ① when the temperature of the air -flow is low at the start of the Heating mode.

2. ADJUST THE RIGHT-LEFT LOUVERS

- Move the Right-Left louvers to adjust air flow in the direction you prefer.

3. SWING OPERATION

To select Vertical Airflow Swing Operation

When the swing signal is received from the remote controller, the vertical louver starts to swing.

(Table10 : Swinging Range)

	Range
Cooling / Dry mode Fan mode (① ~ ③)	① ↔ ④
Heating mode Fan mode (④ ~ ⑥)	④ ↔ ⑥

- The SWING operation may stop temporarily when the air conditioner's fan is not operating, or when operating at very low speeds.

To select Horizontal Airflow Swing Operation

(No function)

8. COMPRESSOR CONTROL

1. OPEARTION FREQUENCY RANGE

The operation frequency of the compressor is different based on the operation mode as shown in the Table 11.

(Table 11 : Compressor frequency range)

	Cooling / Dry		Heating	
	Minimum	Maximum	Minimum	Maximum
AO*G18KLTA	8 rps	94rps	8 rps	102rps
AO*G24KLTA	10rps	102rps	10rps	130rps

2. OPEARTION FREQUENCY CONTROL AT NORMAL START UP

The compressor frequency soon after the start-up is controlled as shown in the Fig.10

(Fig.10 : Compressor control at start-up)

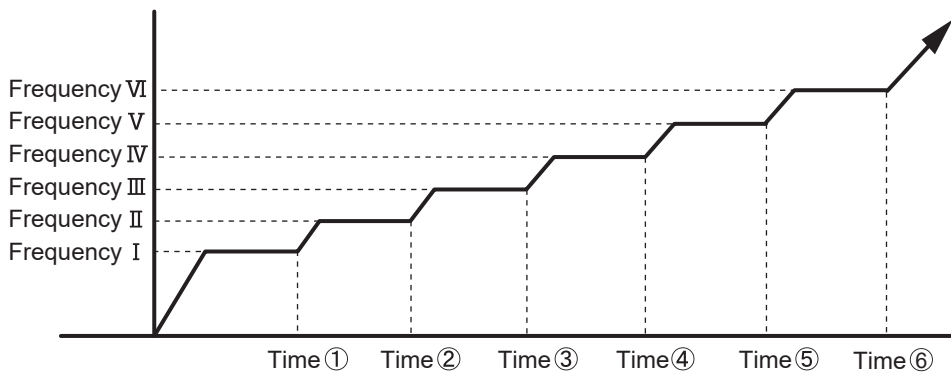

(Frequency)

	Frequency I	Frequency II	Frequency III	Frequency IV	Frequency V	Frequency VI
18KLTA	40rps	56rps	77rps	90rps	99rps	----rps
24KLTA	35rps	52rps	64rps	71rps	89rps	97rps

(Time)

	Time ①	Time ②	Time ③	Time ④	Time ⑤	Time ⑥
18KLTA	60sec	240sec	280sec	360sec	400sec	----sec
24KLTA	60sec	140sec	170sec	200sec	350sec	410sec

3. LIMITATION OF COMPRESSOR FREQUENCY BY OUTDOOR TEMPERATURE

The minimum compressor frequency is limited by outdoor temperature as shown in the Table12.

(Table12 : Limitation of Compressor Frequency)

[Cooling/ Dry]

	38°C		19°C		10°C		0°C	
	Over	Under	Over	Under	Over	Under	Over	Under
AO*G18KLTA	18rps	1rps	16rps	22rps	40rps			
AO*G24KLTA	20rps	1rps	19rps	31rps	33rps			

[Heating]

	19°C		5°C		0°C		-15°C	
	Over	Under	Over	Under	Over	Under	Over	Under
AO*G18KLTA	1rps	1rps	10rps	17rps	25rps			
AO*G24KLTA	1rps	1rps	13rps	21rps	31rps			

9. TIMER OPEARTION CONTROL

9-1 WIRELESS REMOTE CONTROLLER

The Table 13 shows the available timer setting based on the product model.

(Table 13 : Timer Setting)

ON TIMER / OFF TIMER	PROGRAM TIMER	SLEEP TIMER
○	○	○

1. OPEARTION FREQUENCY RANGE

- OFF timer : When the clock reaches the set time, the air conditioner will be turned off.

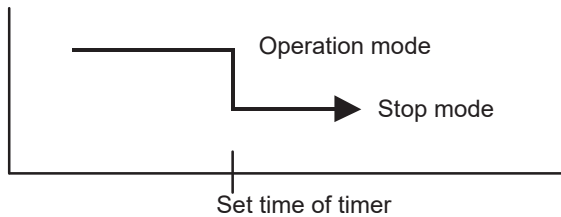

- ON timer : When the clock reaches the set time, the air conditioner will be turned on.

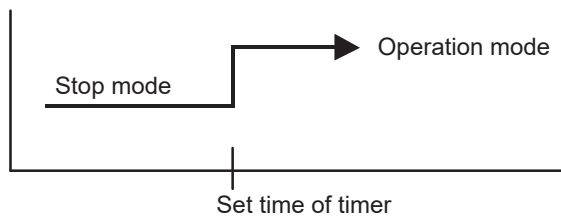

2. PROGRAM TIMER

- The program timer allows the OFF timer and ON timer to be used in combination one time.

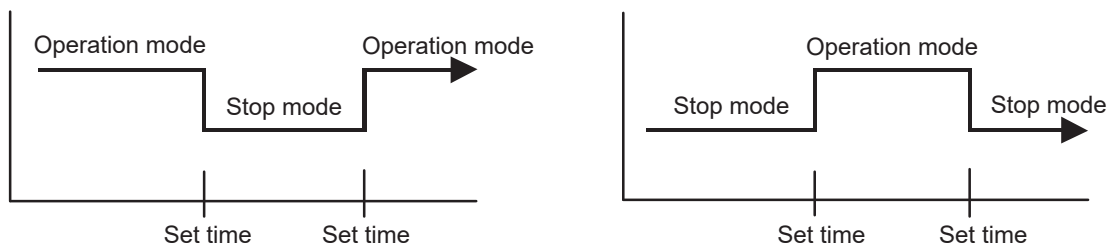

- Operation will start from the timer setting (either OFF timer or ON timer) whichever is closest to the clock's current timer setting.
The order of operations is indicated by the arrow in the remote control unit's display.
- SLEEP timer operation cannot be combined with ON timer operation.

3. SLEEP TIMER

If the sleep is set, the room temperature is monitored and the operation is stopped automatically. If the operation mode or the set temperature is change after the sleep timer is set, the operation is continued according to the changed setting of the sleep timer from that time ON.

In the cooling operation mode

When the sleep timer is set, the setting temperature is increased 1°C. It increases the setting temperature another 1°C after 1 hour. After that, the setting temperature is not changed and the operation is stopped at the time of timer setting.

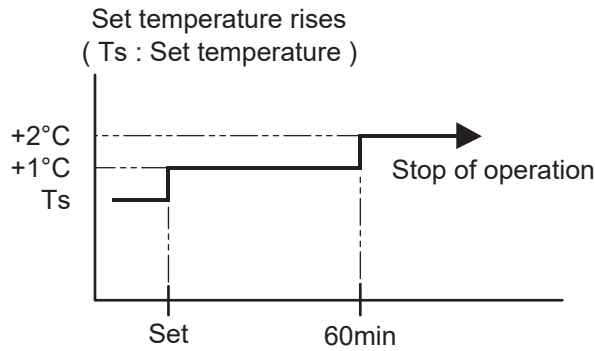

In the heating operation mode

When the sleep timer is set, the setting temperature is decreased 1°C. It decreases the setting temperature another 1°C every 30 minutes. Upon lowering 4°C, the setting temperature is not changed and the operation stops at the time of timer setting.

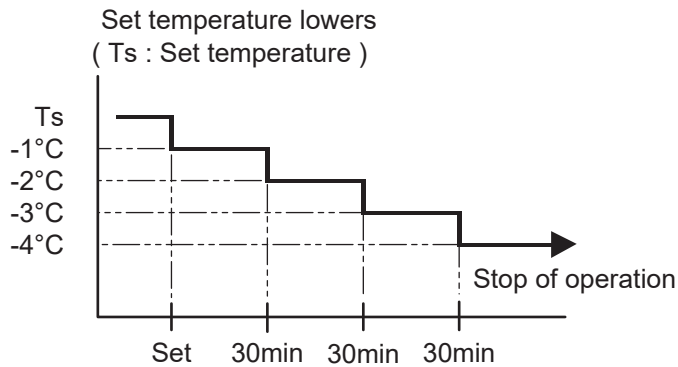

10. ELECTRONIC EXPANSION VALVE CONTROL

The most proper opening of the electronic expansion valve is calculated and controlled under the present operating condition based on the Table14.

The compressor frequency, the detected temperature by the discharge temperature sensor, the indoor heat exchanger sensor, the outdoor heat exchanger sensor, and the outdoor temperature sensor.

(Table14 : The pulse range of the electronic expansion valve control)

	Operation mode	Pulse range
AO*G18KLTA AO*G24KLTA	Cooling / Dry mode	Between 0 to 480 pulses.
	Heating mode	

- * The expansion valve is set at 480 pulses 110seconds after the compressor had stopped.
- * Initialization will start after 24 hours pass from the last initialization, and the compressor stops
- * At the time of supplying the power to the outdoor unit, the initialization of the electronic expansion valve is operated (528 pulses are input to the closing direction).

11. TEST OPERATION CONTROL

[Operation method]

The outdoor unit, may not operate, depending on the room temperature.

In this case, keep on pressing the MANUAL AUTO button of the indoor unit for more than 10 seconds.

The Operation lamp and Timer lamp will begin to flash simultaneously during cooling test run.

Then, heating test run will begin in about 3 minutes when HEAT is selected by the remote control operation.

(When the air conditioner is running by pressing the test run button, the Operation lamp and Timer lamp will simultaneously flash slowly.)

[Release]

Perform the test operation for 60 minutes.

Pressing the MANUAL AUTO button of the indoor unit for more than 3 seconds.

12. PREVENT TO RESTART FOR 3 MINUTES (3 MINUTES ST)

The compressor won't enter operation status for 2 minutes and 20 seconds after the compressor is stopped, even if any operation is given.

13. FOUR-WAY VALVE EXTENSION SELECT

At the time when the air conditioner is switched from the cooling mode to heating mode, the compressor is stopped, and the four-way valve is switched in 3 minutes later after the compressor stopped.

14. AUTO RESTART

When the power was interrupted by a power failure, etc. during operation, the operation contents at that time are memorized and when power is recovered, operation is automatically started with the memorized operation contents.

When the power is interrupted and recovered during timer operation, since the timer operation time is shifted by the time the power was interrupted, an alarm is given by blinking (6 sec ON/2 sec OFF) the indoor unit body timer lamp.

[Operation contents memorized when the power is interrupted]

- Operation mode
- Set temperature
- Set air flow
- Timer mode and set time (set by wireless remote controller)
- Set air flow Direction
- Swing
- ECONOMY operation

15. MANUAL AUTO OPERATION (Indoor unit body operation)

When the remote control is lost or battery power dissipated, this function will work without the remote control. When MANUAL AUTO button is set more than 3seconds and less than 10seconds, MANUAL AUTO OPERATION will be started as shown in Table15.

To stop operation, press the MANUAL AUTO button for 3seconds.

(Table15 : MANUAL AUTO OPERATION)

	Manual auto operation
OPERATION MODE	Auto changeover
FAN CONT. MODE	Auto
TIMER MODE	Continuous (No timer setting available)
SETTING TEMP.	24°C
SETTING LOUVER	Standard
SWING	OFF
ECONOMY	OFF

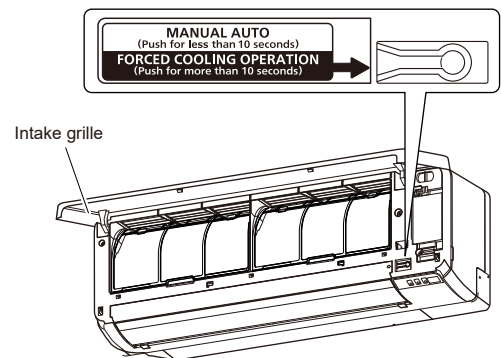

16. FORCED COOLING OPERATION (TEST OPERATION)

When FORCED COOLING OPERATION is set, the operation is controlled as shown in Table16.

(Table16 : FORCED COOLING OPERATION)

	Forced cooling operation
OPERATION MODE	Cooling
FAN CONT. MODE	Hi
TIMER MODE	-
SETTING TEMP.	Room Temp is not controlled
SETTING LOUVER	Horizontal (It is changed follow as setting of remote controller)
SWING	OFF
ECONOMY	-

- Forced cooling operation is started when press MANUAL AUTO button for 10 seconds or more.
- During the forced cooling operation, it operates regardless of room temperature sensor.
- Operation LED and timer LED blink at the same time during the forced cooling operation. They blink for 1 second ON and 1 second OFF on both operation LED and timer LED (same as test operation).
- Forced cooling operation is released after 60 minutes of starting operation or pressing MANUAL AUTO button for 3 seconds.

17. COMPRESSOR PREHEATING

When the outdoor heat exchanger temperature is lower than -4°C and the heating operation has been stopped for 30 minutes, power is applied to the compressor and the compressor is heated. (By heating the compressor, warm air is quickly discharged when operation is started.) When operation was started, and when the outdoor temperature rises to -2°C or greater, preheating is ended.

18. ECONOMY OPERATION

The ECONOMY operation functions by pressing ECONOMY button on the remote controller. At the maximum output, ECONOMY Operation is approximately 70% of normal air conditioner operation for cooling and heating.

The ECONOMY operation is almost the same operation as below settings.

(Table 17)

Mode	Cooling/ Dry	Heating
Target temperature	Setting temp.+1°C	Setting temp.-1°C

19. POWERFUL OPERATION

The POWERFUL OPERATION functions by pressing POWERFUL button on the remote controller. The indoor unit & outdoor unit will operate at maximum power as shown in Table18.

(Table18)

	Powerful operation
COMPRESSOR FREQUENCY	Maximum
FAN CONT. MODE	Powerful
SETTING LOUVER	Cooling/ Dry : 2, Heating : 5

Release Condition is as follows.

[Cooling / Dry]

- Room temperature \leq Setting temperature - 0.5°C or Operation time has passed 20 minutes.

[Heating]

- Room temperature \geq Setting temperature +0.5°C or Operation time has passed 20 minutes.

20. DEFROST OPERATION CONTROL

1. CONDITION OF STARTING THE DEFROST OPERATION

The defrost operation starts when the outdoor heat exchanger temperature sensor (Tn) detects the temperature lower than the values shown in Table19.

(Table 19 : Condition of starting Defrost Operation)

1 ST time defrosting after starting operation	Compressor integrating operation time		
	Less than 22 min.	22 to 62 min.	More than 62 min.
	Does not operate	- 9°C	- 5°C

Defrosting after 2 ND time upon starting operation	Compressor integrating operation time	
	Less than 40 min.	More than 40min.
	Does not operate	Outdoor heat exchanger temp. $\leq -17^{\circ}\text{C}$ (at outside air temp. $\geq -10^{\circ}\text{C}$) ----- ① Outdoor heat exchanger temp. $< -20^{\circ}\text{C}$ ② Outdoor heat exchanger temp. $<$ Outside air temp -7°C . ③ $T_n - T_{n10} < -5^{\circ}\text{C}$ (and $T_n < -6^{\circ}\text{C}$) ④ $T_n - T_{nb} < -2^{\circ}\text{C}$ (and $T_n < -6^{\circ}\text{C}$) (at outside air temp. $< -10^{\circ}\text{C}$)

Tn10 : Temperature of continuous operation at 10minutes.

Tnb : Back 5minutes temperature

Integrating defrost (Constant monitoring)	Compressor integrating operation time		
	More than 240 min. (For long continuous operation)	More than 215 min. (For long continuous operation)	Less than 10min.*1 (For intermittent operation)
	- 3°C	- 5°C	OFF count of the compressor 40 times.

*1 : If the compressor continuous operation time is less than 10 minutes,
the OFF number of the compressor is counted.

If any defrost operated, the compressor OFF count is cleared.

2. CONDITION OF THE DEFROST OPERATION COMPLETION

Defrost operation is released when the conditions become as shown in Table 20.

(Table 20 : Defrost Release Condition)

Release Condition
Outdoor heat exchanger temperature sensor value is higher than $+16^{\circ}\text{C}$. or Compressor operation time has passed 15 minutes.

3. Defrost Flow Chart

The defrosting shall proceed by the integrating operation time, outdoor temperature and outdoor heat exchanger temperature as follows.

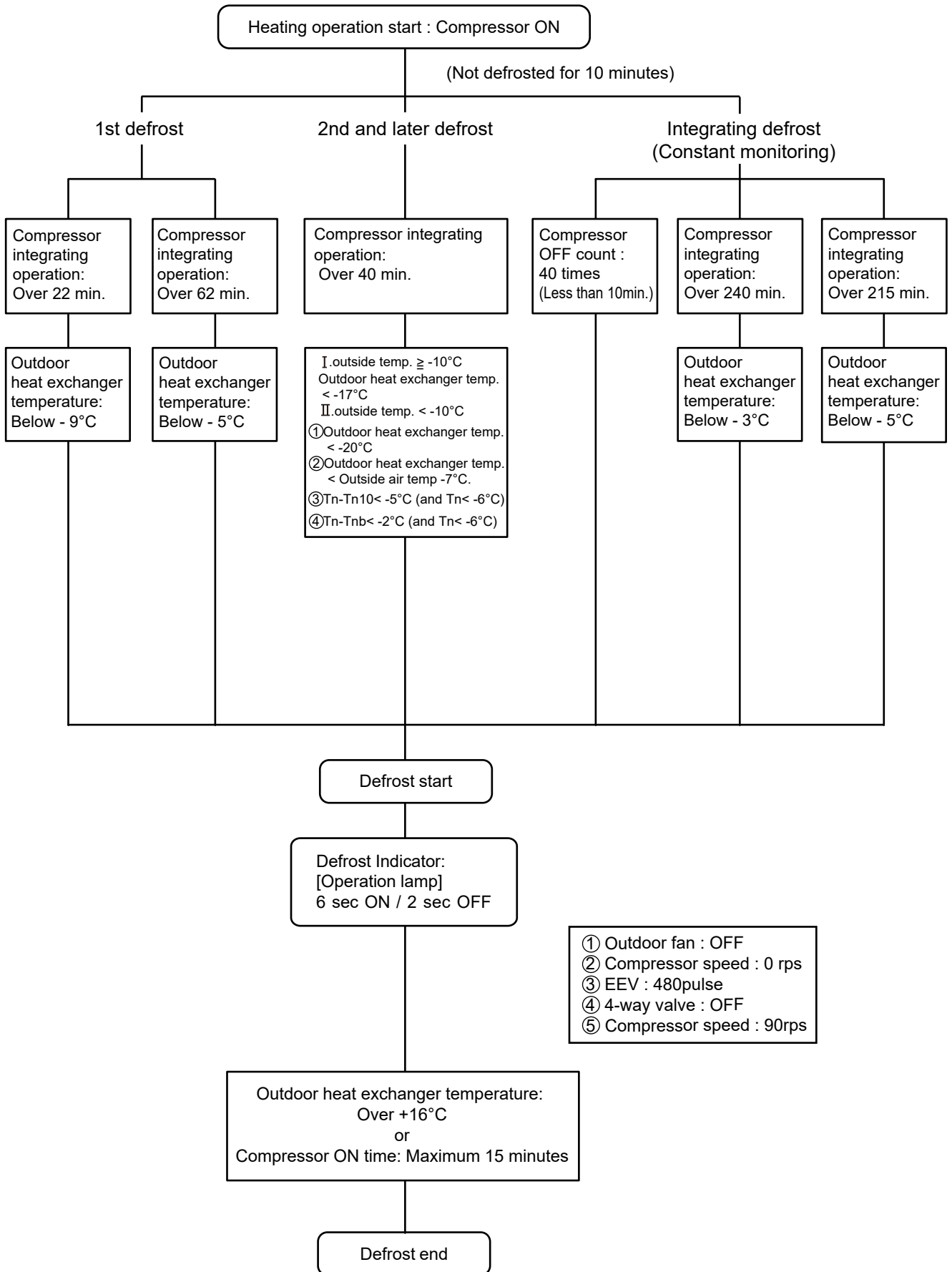

21. OFF DEFROST OPERATION CONTROL

When operation stops in the [Heating operation] mode, if frost is adhered to the outdoor unit heat exchanger, the defrost operation will proceed automatically. In this time, if indoor unit operation lamp flashes slowly (6 sec ON / 2 sec OFF), the outdoor unit will allow the heat exchanger to defrost, and then stop.

1. OFF DEFROST OPERATION CONDITION

In heating operation, the outdoor heat exchanger temperature is less than -4°C , compressor continuous operation more than 10 minutes, and compressor operation integrating time lasts for more than 30 minutes.

2. OFF DEFROST END CONDITION

Release Condition
Outdoor heat exchanger temperature sensor value is higher than 16°C or Compressor operation time has passed 15 minutes.

OFF Defrost Flow Chart

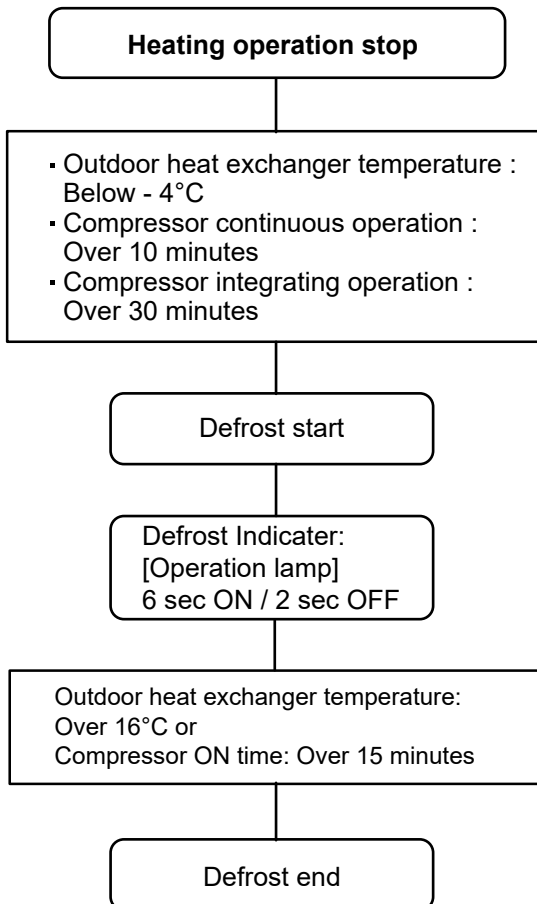

22. VARIOUS PROTECTIONS

1. DISCHARGE GAS TEMPERATURE OVERRISE PREVENION CONTROL

The discharge gas thermosensor (discharge thermistor : Outdoor side) will detect discharge gas temperature.

When the discharge temperature becomes higher than Temperature I, the compressor frequency is decreased 20rps, and it continues to decrease the frequency for 20rps every 120 seconds until the temperature becomes lower than Temperature I.

When the discharge temperature becomes lower than Temperature II, the protection control of the compressor frequency will be released.

When the discharge temperature becomes higher than Temperature III, the compressor is stopped and the indoor unit LED starts blinking.

(Table 21 : Discharge temperature over rise prevention control / Release temperature)

Temperature I	Temperature II	Temperature III
104°C	101°C	110°C

2. CURRENT RELEASE CONTROL

The compressor frequency is controlled so that the outdoor unit input current does not exceed the current limit value that was set up with the outdoor temperature.

The compressor frequency returns to the designated frequency of the indoor unit at the time when the frequency becomes lower than the release value.

(Table 22 : Current release operation value / Release value)

[Heating]

AO*G18KLTA	
OT (Control / Release)	
17°C	7.0A / 6.5A
12°C	9.0A / 8.5A
5°C	11.0A / 10.5A
	13.0A / 12.5A

OT : Outdoor Temperature

[Cooling]

AO*G18KLTA	
OT (Control / Release)	
46°C	4.5A / 4.0A
40°C	6.0A / 5.5A
	9.0A / 8.5A

OT : Outdoor Temperature

[Heating]

AO*G24KLTA	
OT (Control / Release)	
17°C	10.5A / 10.0A
12°C	13.0A / 12.5A
5°C	15.0A / 14.5A
	17.0A / 16.5A

OT : Outdoor Temperature

[Cooling]

AO*G24KLTA	
OT (Control / Release)	
46°C	7.0A / 6.5A
40°C	9.5A / 9.0A
	13.0A / 12.5A

OT : Outdoor Temperature

3. ANTIFREEZING CONTROL (Cooling and Dry mode)

The compressor frequency is decrease on cooling & dry mode when the indoor heat exchanger temperature sensor detects the temperature lower than Temperature I. Then, the anti-freezing control is released when it becomes higher than Temperature II.

(Table 23 : Anti-freezing Protection Operation / Release Temperature)

Outdoor temperature	Temperature I	Temperature II
Over than 10°C *1 or 12°C *2	4°C	7°C
Less than 10°C *1 or 12°C *2		13°C

*1. When the temperature rises.

*2. When the temperature drops.

4. COOLING PRESSURE OVERRISE PROTECTION

When the outdoor unit heat exchange sensor temperature rises to 65°C or greater, the compressor and the outdoor fan motor are stopped and trouble display is performed.

5. HIGH TEMPERATURE RELEASE CONTROL (HEATING MODE)

On heating mode, the compressor frequency is controlled as following based on the detection value of the indoor heat exchanger temperature sensor.

[Control System]

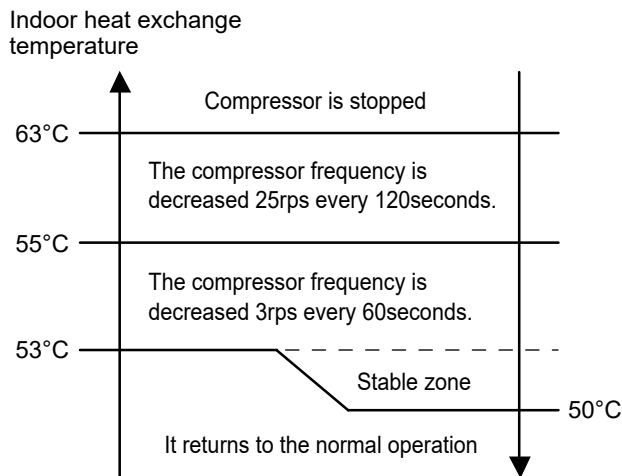

WALL MOUNTED type INVERTER

2 . TROUBLE SHOOTING

2-1 ERROR DISPLAY

2-1-1 INDOOR UNIT DISPLAY

Please refer the flashing pattern as follows.

Indoor Unit : AS*G18/ 24KLCA

The OPERATION, TIMER and ECONOMY lamps operate as follows according to the error contents.

Error Contents	Indoor Unit Display			Error code	Trouble shooting
	OPERATION [I] (Green)	TIMER [⌚] (Orange)	ECONOMY [⌚] (Green)		
Serial communication error	1 times	1 times	Continuous	11	1.2
Indoor Unit Capacity Error	2 times	2 times	Continuous	22	3
Combination Error	2 times	3 times	Continuous	23	4
Indoor unit main PCB error	3 times	2 times	Continuous	32	5
Manual auto switch error	3 times	5 times	Continuous	35	6
Indoor Room Thermistor Error	4 times	1 times	Continuous	41	7
Indoor Heat Ex. Thermistor Error	4 times	2 times	Continuous	42	8
Indoor Unit Fan Motor Error	5 times	1 times	Continuous	51	9
Outdoor unit main PCB error	6 times	2 times	Continuous	62	10
PFC circuit error	6 times	4 times	Continuous	64	11
IPM Error	6 times	5 times	Continuous	65	12
Discharge Thermistor Error	7 times	1 times	Continuous	71	13
Compressor Thermistor Error	7 times	2 times	Continuous	72	14
Heat Ex. Liquid Outlet Thermistor Error	7 times	3 times	Continuous	73	15
Outdoor Thermistor Error	7 times	4 times	Continuous	74	16
Current Sensor Error	8 times	4 times	Continuous	84	17
Pressure Sensor Error	8 times	6 times	Continuous	86	18
Over Current Error	9 times	4 times	Continuous	94	19
Compressor Control Error	9 times	5 times	Continuous	95	20
Outdoor Unit Fan Motor Error	9 times	7 times	Continuous	97	21

Error Contents	Indoor Unit Display			Error code	Trouble shooting
	OPERATION [I] (Green)	TIMER [⊕] (Orange)	ECONOMY [⊞] (Green)		
4-way Valve Error	9 times	9 times	Continuous	99	22
Discharge Temp. Error	10 times	1 times	Continuous	A1	23
Compressor Temp. Error	10 times	3 times	Continuous	A3	24

2-2 TROUBLE SHOOTING WITH ERROR CODE

Trouble shooting 1
OUTDOOR UNIT Error Method:
Serial communication error
(Serial Reverse Transfer Error)

Indicate or Display:

Outdoor Unit : No indication
 Indoor Unit : Operation lamp: 1 time Flash, Timer lamp: 1 time Flash
 Economy lamp: Continuous flash.
ERROR CODE : [E : 11]

Detective Actuators:

Outdoor unit Main PCB
 Outdoor unit fan motor

Detective details:

When the indoor unit cannot receive the serial signal from Outdoor unit more than 2minutes after power ON, or the indoor unit cannot receive the serial signal more than 15seconds during normal operation.

Forecast of Cause:

1. Connection failure
2. External cause
3. Main PCB failure
4. Outdoor unit fan motor failure

Check Point 1-1 : Reset the power and operate

· Does Error indication show again?

YES

NO

Check Point 2 : Check Connection

· Check any loose or removed connection line of Indoor unit and Outdoor unit.
 >> **If there is an abnormal condition, correct it by referring to Installation Manual or Data & Technical Manual.**

Check Point 1-2: Check external cause such as noise

· Check the complete insulation of the grounding.
 · Check if there is any equipment that causes harmonic wave near the power cable (Neon light bulb or any electronic equipment which causes harmonic wave).

OK

Check Point 3 : Check the voltage of power supply

· Check the voltage of power supply
 >> **Check if AC207V (AC230V -10%) - 253V (AC230V +10%) appears at Outdoor Unit Terminal L - N.**



OK

Check Point 4 : Check Serial Signal (Reverse Transfer Signal)

· Check Serial Signal (Reverse Transfer Signal)
 >> **Check if Indicated value swings between AC90V and AC270V at Outdoor Unit Terminal 1 - 3.**
 >> **If it is abnormal, Check Outdoor unit fan motor. (PARTS INFORMATION 5)**
 >> **If Outdoor fan motor is abnormal, replace Outdoor unit fan motor and Main PCB.**
 >> **If Outdoor fan motor is normal, replace Main PCB.**

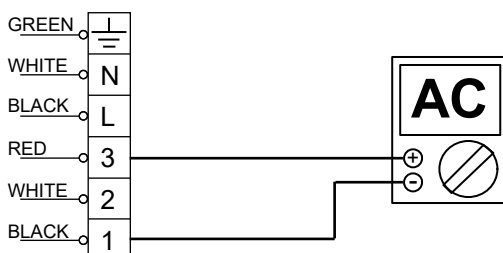

Trouble shooting 2 INDOOR UNIT Error Method: Serial communication error (Serial Forward Transfer Error)	Indicate or Display: Outdoor Unit : No indication Indoor Unit : Operation lamp: 1 time Flash, Timer lamp: 1 time Flash Economy lamp: Continuous flash. ERROR CODE : [E : 11]
--	--

Detective Actuators: Indoor unit Main PCB Indoor unit Fan motor	Detective details: When the outdoor unit cannot receive the serial signal from Indoor unit more than 10seconds.
--	---

Forecast of Cause:
1. Connection failure 2. External cause 3. Main PCB failure 4. Indoor unit fan motor failure

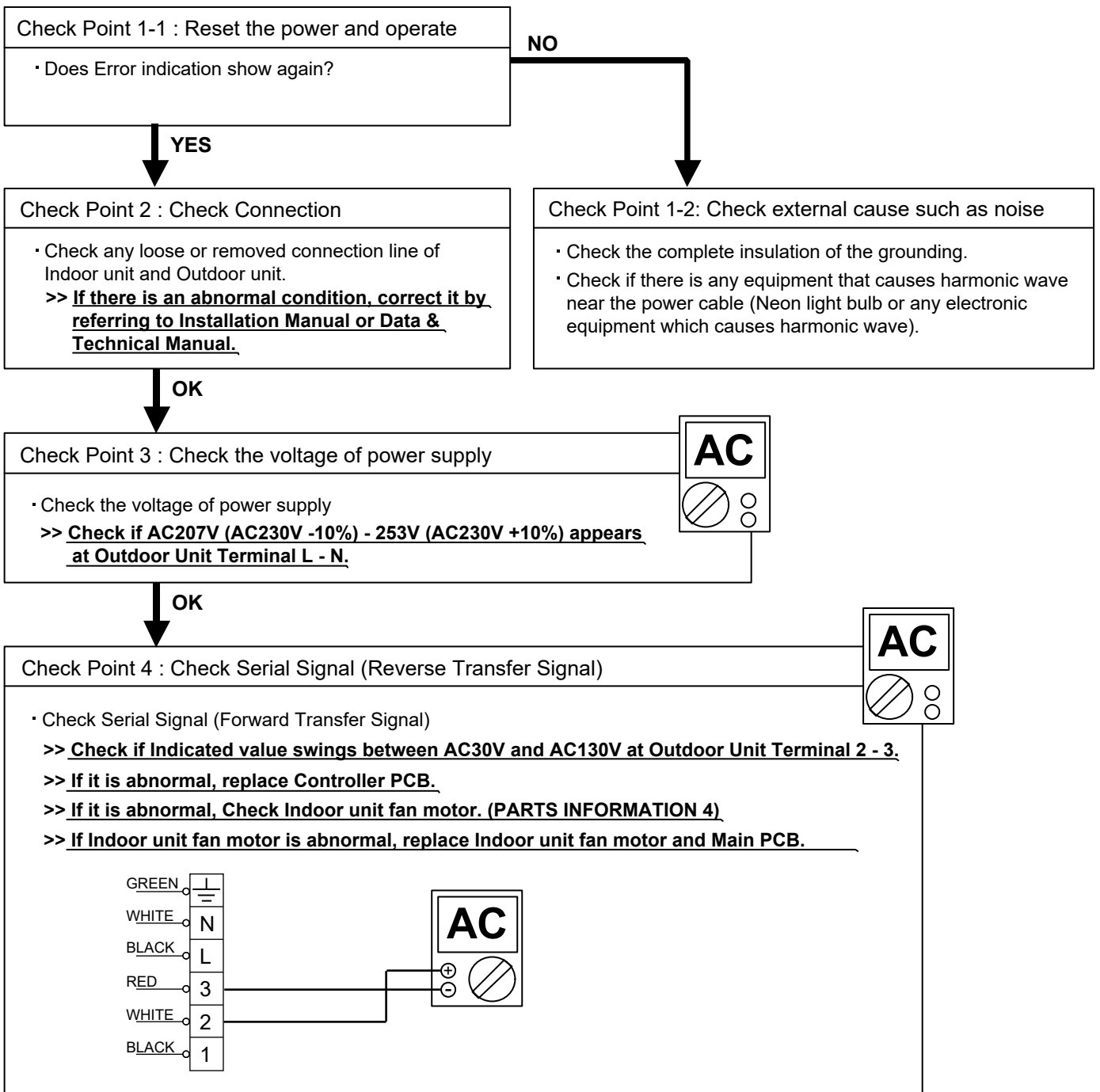

<p>Trouble shooting 3 <u>INDOOR UNIT Error Method:</u> Indoor unit capacity error</p>	<p><u>Indicate or Display:</u> Outdoor Unit : No indication Indoor Unit : Operation lamp: 2 time Flash, Timer lamp: 2 time Flash Economy lamp: Continuous flash. ERROR CODE : [E : 22]</p>
--	---

<p><u>Detective Actuators:</u> Indoor Unit Main PCB</p>	<p><u>Detective details:</u> When the total capacity of indoor units does not match outdoor capacity while 3 minutes after power-on.</p>
---	--

<p><u>Forecast of Cause :</u> 1. The selection of indoor units is incorrect 2. Main PCB failure</p>
--

<p>Check Point 1 : Check the total capacity of indoor unit</p>
<ul style="list-style-type: none"> · Check the total capacity of the connected indoor units. >> <u>If abnormal condition is found, correct it by referring to Installation Manual or Data & Technical Manual.</u>



<p>Check Point 2 : Replace Main PCB</p>
<p>▶ <u>If Check Point 1 do not improve the symptom, replace Main PCB.</u></p>

<p>Trouble shooting 4 <u>INDOOR UNIT Error Method:</u> Combination error</p>	<p><u>Indicate or Display:</u> Outdoor Unit : No indication Indoor Unit : Operation lamp: 2 time Flash, Timer lamp: 3 time Flash Economy lamp: Continuous flash. ERROR CODE : [E : 23]</p>
---	---

<p><u>Detective Actuators:</u> Indoor unit</p>	<p><u>Detective details:</u> 1. When the outdoor unit type is multi.</p>
--	--

<p><u>Forecast of Cause:</u> 1. The selection of indoor units is incorrect</p>
--

<p>Check Point 1 : Check the type of indoor unit</p>
<p>· Check the type of the connected indoor unit. <u>>> If abnormal condition is found, correct it.</u></p>



<p>Check Point 2 : Replace Main PCB</p>
<p>► <u>If Check Point 1 do not improve the symptom, replace Main PCB of Outdoor unit.</u></p>

Trouble shooting 5 <u>INDOOR UNIT Error Method:</u> Indoor unit Main PCB error	<u>Indicate or Display:</u> Outdoor Unit : No indication Indoor Unit : Operation lamp: 3 time Flash, Timer lamp: 2 time Flash Economy lamp: Continuous flash. ERROR CODE : [E : 32]
---	---

<u>Detective Actuators:</u> Indoor unit Main PCB	<u>Detective details:</u> When power is on and there is some below case. 1. When model information of EEPROM is incorrect. 2. When the access to EEPROM failed.
--	---

<u>Forecast of Cause:</u> 1. External cause 2. Defective connection of electric components 3. Main PCB failure
--

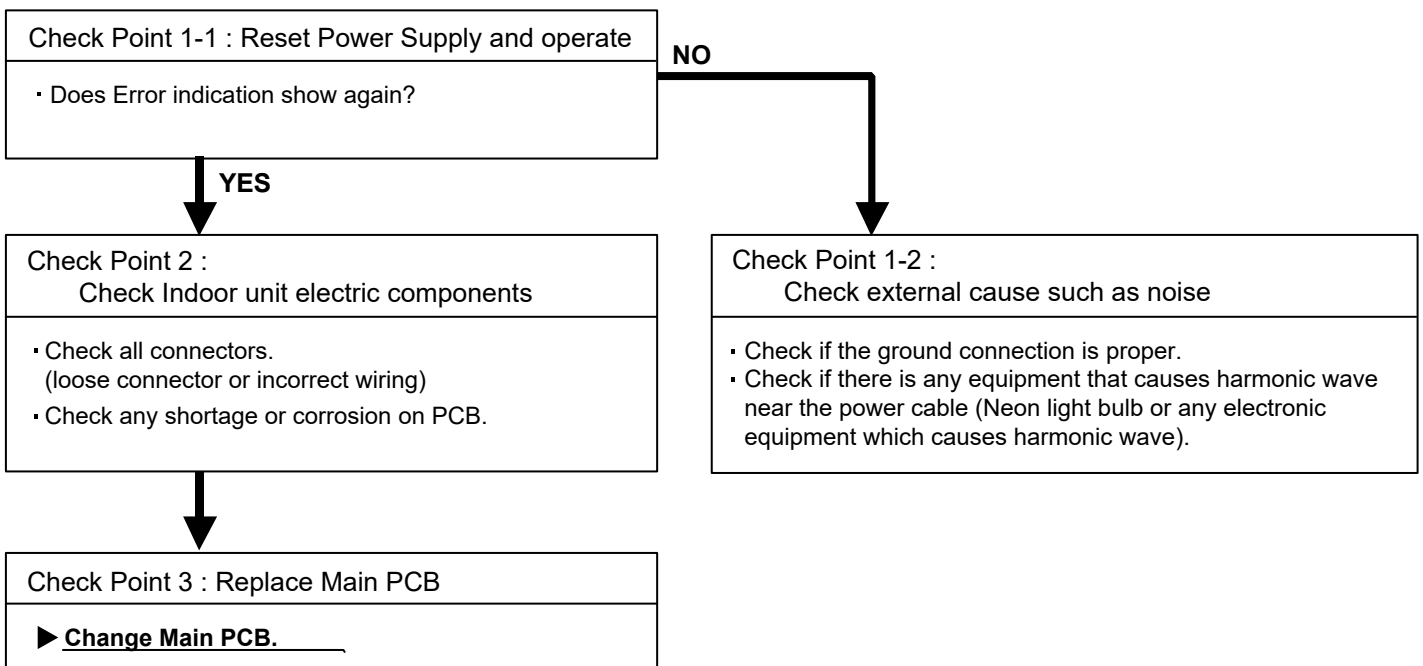



Note : EEPROM

EEPROM(Electronically Erasable and Programmable Read Only Memory) is a non-volatile memory which keeps memorized information even if power is turned off. It can change the contents electronically. To change the contents, it uses higher voltage than normal, and it can not change a partial contents. (Rewriting shall be done upon erasing the all contents.) There is a limit in a number of rewriting.

<p>Trouble shooting 6 INDOOR UNIT Error Method: Manual auto switch Error</p>	<p>Indicate or Display: Outdoor Unit : No indication Indoor Unit : Operation lamp: 3 time Flash, Timer lamp: 5 time Flash Economy lamp: Continuous flash. ERROR CODE : [E : 35]</p>
---	--

<p>Detective Actuators: Indoor unit Main PCB Indicator PCB Manual auto switch</p>	<p>Detective details: When the Manual Auto Switch becomes ON for consecutive 60 or more seconds.</p>
---	--

Forecast of Cause :
1. Manual auto switch failure 2. Main PCB and Indicator PCB failure

<p>Check Point 1 : Check the Manual auto switch</p>	
<ul style="list-style-type: none"> • Check if Manual auto switch is kept pressed. • Check ON/OFF switching operation by using a meter. <p>>> If Manual auto switch is disabled (on/off switching), replace it.</p>	



<p>Check Point 2 : Replace MainPCB and Indicator PCB</p>
<p>▶ If Check Point 1 do not improve the symptom, replace Main PCB and Indicator PCB.</p>

Trouble shooting 7 INDOOR UNIT Error Method: Indoor Room Thermistor Error	Indicate or Display: Outdoor Unit : No indication Indoor Unit : Operation lamp: 4 time Flash, Timer lamp: 1 time Flash Economy lamp: Continuous flash. ERROR CODE : [E : 41]
--	---

Detective Actuators: Indoor unit Main PCB Room temperature thermistor	Detective details: When Room Temperature Thermistor open or short-circuit is detected.
--	--

Forecast of Cause :
1. Connector connection failure 2. Thermistor failure 3. Main PCB failure

Check Point 1 : Check connection of Connector

- Check if connector is removed.
- Check erroneous connection.
- Check if thermistor cable is open.

>>Upon correcting the removed connector or mis-wiring, reset the power.



Check Point 2 : Remove connector and check Thermistor resistance value

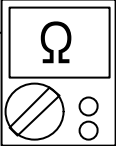

Thermistor Characteristics (Approx. value)

Temperature	-10°C	-5°C	0°C	5°C	10°C	15°C	20°C	25°C
Resistance Value (kΩ)	58.2	44.0	33.6	25.9	20.2	15.8	12.5	10.0

Temperature	30°C	35°C	40°C	45°C
Resistance Value (kΩ)	8.0	6.5	5.3	4.3

► If Thermistor is either open or shorted, replace it and reset the power.



Check Point 3 : Check voltage of Main PCB (DC5.0V)



Make sure circuit diagram of indoor unit and check terminal voltage at Thermistor (DC5.0V)

THERMISTOR (PIPE)	
BLACK	1 1
BLACK	2 2
BLACK	3 3
BLACK	4 4
THERMISTOR (ROOM TEMP.)	CN4

► If the voltage does not appear, replace Main PCB.

Trouble shooting 8 INDOOR UNIT Error Method: Indoor Heat Ex. Thermistor Error	Indicate or Display: Outdoor Unit : No indication Indoor Unit : Operation lamp: 4 time Flash, Timer lamp: 2 time Flash Economy lamp: Continuous flash. ERROR CODE : [E : 42]
--	---

Detective Actuators: Indoor unit Main PCB Heat Ex. temperature thermistor	Detective details: When Heat Ex. Temperature Thermistor open or short-circuit is detected.
--	--

Forecast of Cause :
1. Connector connection failure 2. Thermistor failure 3. Main PCB failure

Check Point 1 : Check connection of Connector

- Check if connector is removed.
- Check erroneous connection.
- Check if thermistor cable is open.

>>Upon correcting the removed connector or mis-wiring, reset the power.



Check Point 2 : Remove connector and check Thermistor resistance value

Thermistor Characteristics (Approx. value)

Temperature	-30°C	-20°C	-10°C	-5°C	0°C	5°C	10°C	20°C
Resistance Value (kΩ)	1131.9	579.6	312.3	233.2	176.0	134.2	103.3	62.9

Temperature	30°C	40°C	50°C	60°C	63°C
Resistance Value (kΩ)	39.6	25.6	17.1	11.6	10.4

► **If Thermistor is either open or shorted, replace it and reset the power.**



Check Point 3 : Check voltage of Main PCB (DC5.0V)

Make sure circuit diagram of indoor unit and check terminal voltage at Thermistor (DC5.0V)

THERMISTOR (PIPE) 	<table border="1" style="border-collapse: collapse;"> <tr><td>1</td><td>1</td></tr> <tr><td>2</td><td>2</td></tr> <tr><td>3</td><td>3</td></tr> <tr><td>4</td><td>4</td></tr> </table> CN4	1	1	2	2	3	3	4	4
1	1								
2	2								
3	3								
4	4								
THERMISTOR (ROOM TEMP.)									

► **If the voltage does not appear, replace Main PCB.**

Trouble shooting 9 INDOOR UNIT Error Method: Indoor Unit Fan Motor Error	Indicate or Display: Outdoor Unit : No indication Indoor Unit : Operation lamp: 5 time Flash, Timer lamp: 1 time Flash Economy lamp: Continuous flash. ERROR CODE : [E : 51]
---	---

Detective Actuators: Indoor unit Main PCB Indoor unit Fan motor	Detective details: When the condition that actual frequency of Indoor Fan is below 1/3 of target frequency is continued more than 56 seconds.
--	---

Forecast of Cause: 1. Fan rotation failure 2. Fan motor winding open 3. Motor protection by surrounding temperature rise 4. Main PCB failure 5. Indoor unit fan motor failure

Check Point 1 : Check rotation of Fan
<ul style="list-style-type: none"> · Rotate the fan by hand when operation is off. (Check if fan is caught, dropped off or locked motor) >>If Fan or Bearing is abnormal, replace it.

↓
OK

Check Point 2 : Check ambient temp. around motor
<ul style="list-style-type: none"> · Check excessively high temperature around the motor. (If there is any surrounding equipment that causes heat) >>Upon the temperature coming down, restart operation.

↓
OK

Check Point 3 : Check Indoor unit fan motor
<ul style="list-style-type: none"> · Check Indoor unit fan motor. (PARTS INFORMATION 4) >>If Indoor unit fan motor is abnormal, replace Indoor unit fan motor.

↓
OK

Check Point 4 : Replace Main PCB
<p style="margin-left: 20px;">▶ <u>If Check Point 1- 3 do not improve the symptom, replace Main PCB.</u></p>

Trouble shooting 10 OUTDOOR UNIT Error Method: Outdoor unit main PCB error	Indicate or Display: Outdoor Unit : No indication Indoor Unit : Operation lamp: 6 time Flash, Timer lamp: 2 time Flash Economy lamp: Continuous flash. ERROR CODE : [E : 62]
---	---

Detective Actuators: Outdoor unit Main PCB	Detective details: Access to EEPROM failed due to some cause after outdoor unit started.
--	--

Forecast of Cause: 1. External cause (Noise, temporary open, voltage drop) 2. Main PCB failure
--

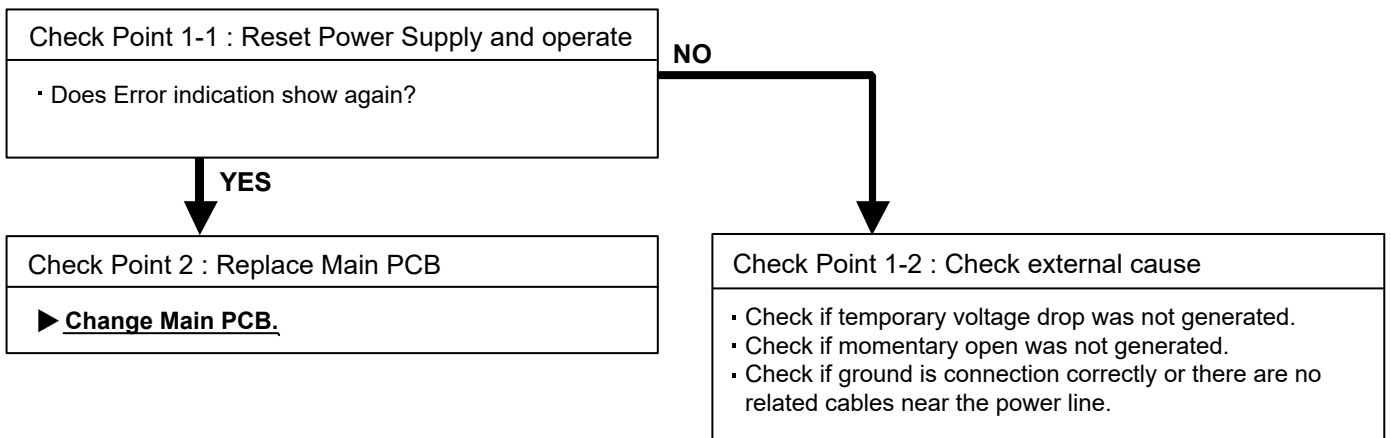

<p>Trouble shooting 11 <u>OUTDOOR UNIT Error Method:</u> PFC circuit error</p>	<p><u>Indicate or Display:</u> Outdoor Unit : No indication Indoor Unit : Operation lamp: 6 time Flash, Timer lamp: 4 time Flash Economy lamp: Continuous flash. ERROR CODE : [E : 64]</p>
---	---

<p><u>Detective Actuators:</u> Outdoor unit Main PCB</p>	<p><u>Detective details:</u> When inverter output DC voltage is higher than 415V for over 3 seconds, the compressor stops. If the same operation is repeated 5 times, the compressor stops permanently.</p>
--	--

<p><u>Forecast of Cause :</u> 1. External cause 2. Connector connection failure 3. Main PCB failure</p>

<p>Check Point 1 : Check external cause at Indoor and Outdoor (Voltage drop or Noise)</p>
<ul style="list-style-type: none"> • Instant drop : Check if there is a large load electric apparatus in the same circuit. • Momentary power failure : Check if there is a defective contact or leak current in the power supply circuit. • Noise : Check if there is any equipment causing harmonic wave near electric line. (Neon bulb or electric equipment that may cause harmonic wave) Check the complete insulation of grounding.



<p>Check Point 2 : Check connection of Connector</p>
<ul style="list-style-type: none"> • Check if connector is removed. • Check erroneous connection. • Check if cable is open. <p>>><u>Upon correcting the removed connector or mis-wiring, reset the power.</u></p>



<p>Check Point 3 : Replace Main PCB</p>
<p>▶ <u>If Check Point 1, 2 do not improve the symptom, change Main PCB.</u></p>

Trouble shooting 12 OUTDOOR UNIT Error Method: IPM Error	Indicate or Display: Outdoor Unit : No indication Indoor Unit : Operation lamp: 6 time Flash, Timer lamp: 5 time Flash Economy lamp: Continuous flash. ERROR CODE : [E : 65]
---	---

Detective Actuators: Outdoor unit Main PCB Compressor Outdoor Fan Motor	Detective details: ① When more than normal operating current to IPM in Main PCB flows, the compressor stops. ② After the compressor restarts, if the same operation is repeated within 40sec, the compressor stops again. ③ If ① and ② repeats 5 times, the compressor stops permanently.
---	---

Forecast of Cause : 1. Defective connection of electric components 2. Outdoor Fan Operation failure 3. Outdoor Heat Exchanger clogged 4. Compressor failure 5. Main PCB failure		
---	--	--

Check Point 1 : Check connections of Outdoor Unit Electrical Components
<ul style="list-style-type: none"> • Check if the terminal connection is loose. • Check if connector is removed. • Check erroneous connection. • Check if cable is open. <p>>> Upon correcting the removed connector or mis-wiring, reset the power.</p>



Check Point 2 : Check Outdoor Fan, Heat Exchanger
<ul style="list-style-type: none"> • Is there anything obstructing the air distribution circuit? • Is there any clogging of Outdoor Heat Exchanger? • Is the Fan rotating by hand when operation is off ? <p>>> If the Fan Motor is locked, replace it.</p>



Check Point 3 : Check Outdoor Fan
<ul style="list-style-type: none"> • Check Outdoor Fan Motor. (Refer to Trouble shooting 21) <p>>> If the Fan Motor is failure, replace it.</p>



Check Point 4 : Check Compressor
<ul style="list-style-type: none"> • Check Compressor. (PARTS INFORMATION 2)



Check Point 5 : Replace Main PCB
<p>► If Check Point 1~ 4 do not improve the symptom, change Main PCB.</p>

Trouble shooting 13
OUTDOOR UNIT Error Method:
Discharge Thermistor Error

Indicate or Display:
Outdoor Unit : No indication
Indoor Unit : Operation lamp: 7 time Flash, Timer lamp: 1 time Flash
Economy lamp: Continuous flash.
ERROR CODE : [E : 71]

Detective Actuators:
 Outdoor unit Main PCB
 Discharge pipe temperature thermistor

Detective details:
 When Discharge pipe temperature thermistor open or short-circuit is detected at power ON or while running the compressor.

Forecast of Cause :

1. Connector connection failure 2. Thermistor failure 3. Main PCB failure

Check Point 1 : Check connection of Connector

- Check if connector is removed.
 - Check erroneous connection.
 - Check if thermistor cable is open.
- >>Upon correcting the removed connector or mis-wiring, reset the power.**



Check Point 2 : Remove connector and check Thermistor resistance value

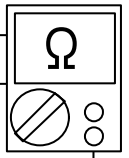

Thermistor Characteristics (Approx. value)

Temperature	-30°C	-20°C	-10°C	-5°C	0°C	5°C	10°C	20°C	30°C
Resistance Value (kΩ)	1013.1	531.6	292.9	221.1	168.6	129.8	100.9	62.5	40.0

Temperature	40°C	50°C	60°C	70°C	80°C	90°C	100°C	110°C	120°C
Resistance Value (kΩ)	26.3	17.8	12.3	8.7	6.3	4.6	3.4	2.6	2.0

► If Thermistor is either open or shorted, replace it and reset the power.



Check Point 3 : Check voltage of Main PCB (DC5.0V)



Make sure circuit diagram of outdoor unit and check terminal voltage at Thermistor (DC5.0V)

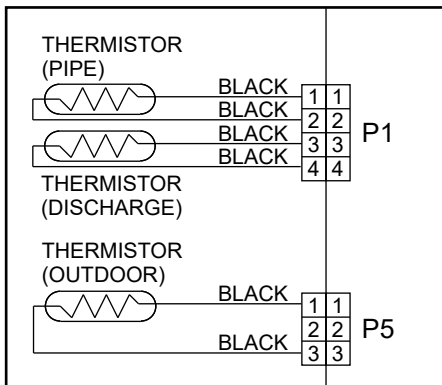

► If the voltage does not appear, replace Main PCB.

[24KLTA]

<p>Trouble shooting 14 <u>OUTDOOR UNIT Error Method</u> Compressor Thermistor Error :</p>	<p><u>Indicate or Display:</u> Outdoor Unit : No indication Indoor Unit : Operation lamp: 7 time Flash, Timer lamp: 2 time Flash Economy lamp: Continuous flash. ERROR CODE : [E : 72]</p>
--	---

<p><u>Detective Actuators:</u> Outdoor unit Main PCB Compressor temperature thermistor</p>	<p><u>Detective details:</u></p> <ul style="list-style-type: none"> • Compressor temperature thermistor short detected • Compressor thermistor open detected
---	---

<p><u>Forecast of Cause :</u> 1. Connector connection failure, open 2. Thermistor failure 3. Main PCB failure</p>
--

<p>Check Point 1 : Check the connector connection and cable open</p>
<p><input type="checkbox"/> Connector connection state check <input type="checkbox"/> Cable open check</p>



<p>Check Point 2 : Remove connector and check Thermistor resistance value</p> <p>Thermistor Characteristics (Approx. value)</p> <table border="1" style="width: 100%; text-align: center;"> <tr> <td>Temperature</td> <td>-30°C</td> <td>-20°C</td> <td>-10°C</td> <td>-5°C</td> <td>0°C</td> <td>5°C</td> <td>10°C</td> <td>20°C</td> <td>30°C</td> </tr> <tr> <td>Resistance Value (kΩ)</td> <td>1013.1</td> <td>531.6</td> <td>292.9</td> <td>221.1</td> <td>168.6</td> <td>129.8</td> <td>100.9</td> <td>62.5</td> <td>40.0</td> </tr> </table> <table border="1" style="width: 100%; text-align: center;"> <tr> <td>Temperature</td> <td>40°C</td> <td>50°C</td> <td>60°C</td> <td>70°C</td> <td>80°C</td> <td>90°C</td> <td>100°C</td> <td>110°C</td> <td>120°C</td> </tr> <tr> <td>Resistance Value (kΩ)</td> <td>26.3</td> <td>17.8</td> <td>12.3</td> <td>8.7</td> <td>6.3</td> <td>4.6</td> <td>3.4</td> <td>2.6</td> <td>2.0</td> </tr> </table> <p>▶ <u>If Thermistor is either open or shorted, replace it and reset the power.</u></p>	Temperature	-30°C	-20°C	-10°C	-5°C	0°C	5°C	10°C	20°C	30°C	Resistance Value (kΩ)	1013.1	531.6	292.9	221.1	168.6	129.8	100.9	62.5	40.0	Temperature	40°C	50°C	60°C	70°C	80°C	90°C	100°C	110°C	120°C	Resistance Value (kΩ)	26.3	17.8	12.3	8.7	6.3	4.6	3.4	2.6	2.0	
Temperature	-30°C	-20°C	-10°C	-5°C	0°C	5°C	10°C	20°C	30°C																																
Resistance Value (kΩ)	1013.1	531.6	292.9	221.1	168.6	129.8	100.9	62.5	40.0																																
Temperature	40°C	50°C	60°C	70°C	80°C	90°C	100°C	110°C	120°C																																
Resistance Value (kΩ)	26.3	17.8	12.3	8.7	6.3	4.6	3.4	2.6	2.0																																



<p>Check Point 3 : Check voltage of Main PCB (DC5.0V)</p> <p><input type="checkbox"/> Main PCB P15:1-3 voltage value =5V <u>Remove the thermistor from Main PCB, check the voltage.</u></p>	
<p>▶ <u>If the voltage does not appear, replace Main PCB, and execute the check operation again.</u></p>	

Trouble shooting 15 OUTDOOR UNIT Error Method: Heat Ex. Liquid Outlet Thermistor Error	Indicate or Display: Outdoor Unit : No indication Indoor Unit : Operation lamp: 7 time Flash, Timer lamp: 3 time Flash Economy lamp: Continuous flash. ERROR CODE : [E : 73]
---	---

Detective Actuators: Outdoor unit Main PCB Heat exchanger temperature thermistor	Detective details: When Heat exchanger temperature thermistor open or short-circuit is detected at power ON or while running the compressor.
---	--

Forecast of Cause :
1. Connector connection failure 2. Thermistor failure 3. Main PCB failure

Check Point 1 : Check connection of Connector

- Check if connector is removed.
- Check erroneous connection.
- Check if thermistor cable is open.

>>Upon correcting the removed connector or mis-wiring, reset the power.



Check Point 2 : Remove connector and check Thermistor resistance value

Thermistor Characteristics (Approx. value)

Temperature	-30°C	-20°C	-10°C	-5°C	0°C	5°C	10°C	20°C	30°C
Resistance Value (kΩ)	95.6	50.3	27.8	21.0	16.1	12.4	9.6	6.0	3.8

Temperature	40°C	50°C	60°C	70°C	80°C
Resistance Value (kΩ)	2.5	1.7	1.2	0.8	0.6

► If Thermistor is either open or shorted, replace it and reset the power.



Check Point 3 : Check voltage of Main PCB (DC5.0V)

Make sure circuit diagram of outdoor unit and check terminal voltage at Thermistor (DC5.0V)

► If the voltage does not appear, replace Main PCB.

Trouble shooting 16 OUTDOOR UNIT Error Method: Outdoor Thermistor Error	Indicate or Display: Outdoor Unit : No indication Indoor Unit : Operation lamp: 7 time Flash, Timer lamp: 4 time Flash Economy lamp: Continuous flash. ERROR CODE : [E : 74]
--	---

Detective Actuators: Outdoor unit Main PCB Outdoor temperature thermistor	Detective details: When Outdoor temperature thermistor open or short-circuit is detected at power ON or while running the compressor.
--	---

Forecast of Cause :
1. Connector connection failure 2. Thermistor failure 3. Main PCB failure

Check Point 1 : Check connection of Connector

- Check if connector is removed.
- Check erroneous connection.
- Check if thermistor cable is open.

>>Upon correcting the removed connector or mis-wiring, reset the power.

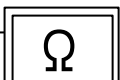

Check Point 2 : Remove connector and check Thermistor resistance value 

Thermistor Characteristics (Approx. value)

Temperature	-30°C	-25°C	-20°C	-15°C	-10°C	-5°C	0°C	5°C	10°C
Resistance Value (kΩ)	224.3	159.7	115.2	84.2	62.3	46.6	35.2	26.9	20.7

Temperature	15°C	20°C	25°C	30°C	35°C	40°C	45°C	50°C	55°C
Resistance Value (kΩ)	16.1	12.6	10.0	8.0	6.4	5.2	4.2	3.5	2.8

► If Thermistor is either open or shorted, replace it and reset the power.



Check Point 3 : Check voltage of Main PCB (DC5.0V) 

Make sure circuit diagram of outdoor unit and check terminal voltage at Thermistor (DC5.0V)

► If the voltage does not appear, replace Main PCB.

Trouble shooting 17 OUTDOOR UNIT Error Method: Current Sensor Error	Indicate or Display: Outdoor Unit : No indication Indoor Unit : Operation lamp: 8 time Flash, Timer lamp: 4 time Flash Economy lamp: Continuous flash. ERROR CODE : [E : 84]
--	---

Detective Actuators: Outdoor unit Main PCB	Detective details: When Input Current Sensor has detected 0A, while Inverter Compressor is operating at higher than 56rps, after 1minute upon starting the Compressor. (Except during the defrost operation)
--	--

Forecast of Cause : 1. Defective connection of electric components 2. External cause 3. Main PCB failure
--

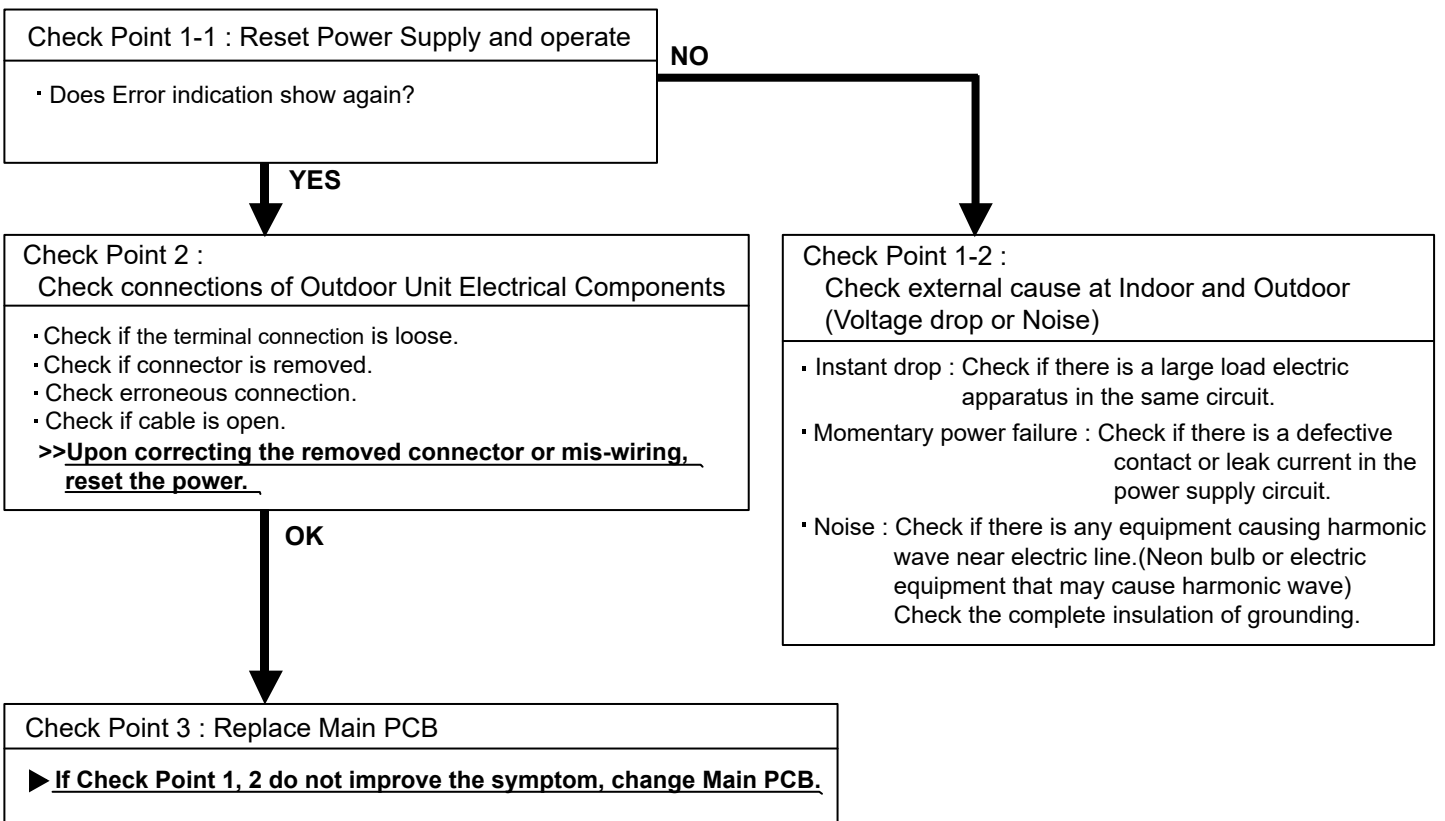

[24KLTA]

<p>Trouble shooting 18 OUTDOOR UNIT Error Method: Pressure Sensor Error</p>	<p>Indicate or Display: Outdoor Unit : No indication Indoor Unit : Operation lamp: 8 time Flash, Timer lamp: 6 time Flash Economy lamp: Continuous flash. ERROR CODE : [E : 86]</p>
--	---

<p>Detective Actuators: High pressure switch</p>	<p>Detective details: · When the power was turned on, "high pressure switch : open" was detected.</p>
--	---

<p>Forecast of Cause :</p> <ol style="list-style-type: none"> 1. High pressure switch connector disconnection, open 2. High pressure switch characteristics failure 3. Main PCB failure

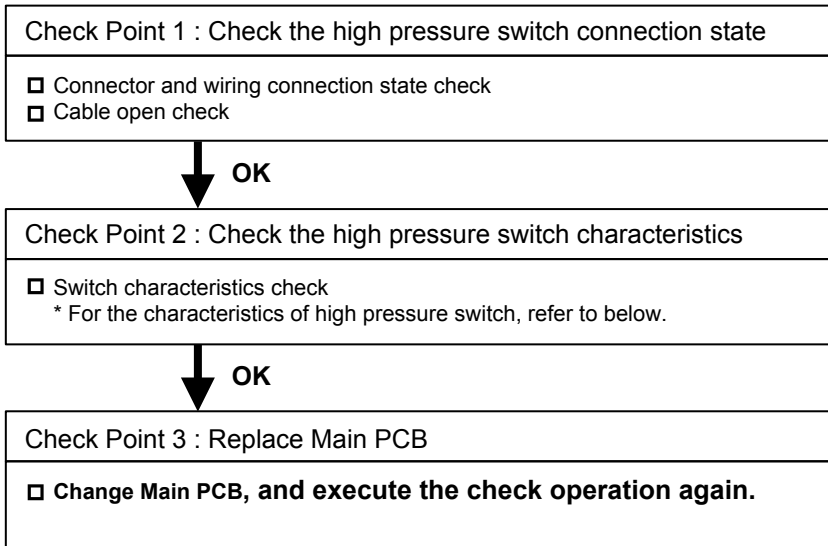

▪ Type of contact

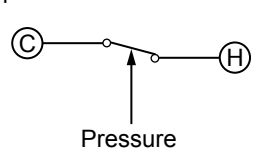

Pressure

▪ Characteristics of pressure switch(P20)

	Pressure switch 1
Contact : Short ⇒ Open	4.2±0.1MPa
Contact : Open ⇒ Short	3.2±0.15MPa

Trouble shooting 19 <u>OUTDOOR UNIT Error Method:</u> Over Current Error	<u>Indicate or Display:</u> Outdoor Unit : No indication Indoor Unit : Operation lamp: 9 time Flash, Timer lamp: 4 time Flash Economy lamp: Continuous flash. ERROR CODE : [E : 94]
---	--

<u>Detective Actuators:</u> Outdoor unit Main PCB Compressor	<u>Detective details:</u> ▪ "Protection stop by overcurrent generation after inverter compressor start processing completed" generated consecutively 10 times. * The number of generations is reset if the start-up of the compressor succeeds.
---	---

<u>Forecast of Cause :</u> <ol style="list-style-type: none"> 1. Outdoor unit fan operation defective, foreign matter on hear exchanger, excessive rise of ambient temperature 2. Inverter PCB failure 3. Inverter compressor failure (lock, winding short)

Check Point 1 : Check the outdoor unit fan operation, heat exchanger, ambient temperature <ul style="list-style-type: none"> • No obstructions in air passages? • Heat exchange fins clogged • Outdoor unit fan motor check • Ambient temperature not raised by the effect of other heat sources? • Discharged air not sucked in?
--

↓ **OK**

Check Point 2: Replace Main PCB ▶ <u>If Check Point 1 do not improve the symptom, change Main PCB.</u>

↓ **OK**

Check Point 3: Replace Compressor ▶ <u>If Check Point 2 do not improve the symptom, change Compressor.</u>

Trouble shooting 20 OUTDOOR UNIT Error Method: Compressor Control Error	Indicate or Display: Outdoor Unit : No indication Indoor Unit : Operation lamp: 9 time Flash, Timer lamp: 5 time Flash Economy lamp: Continuous flash. ERROR CODE : [E : 95]
--	--

Detective Actuators: Outdoor unit Main PCB Compressor	Detective details: ① If the detected rotor location is out of phase with actual rotor location more than 90°, the compressor stops. After the compressor restarts, if the same operation is repeated ② within 40sec, the compressor stops again. ③ If ① and ② repeats 5 times, the compressor stops permanently.
--	---

Forecast of Cause : 1. Defective connection of electric components 2. Main PCB failure 3. Compressor failure
--

Check Point 1 : Check Noise from Compressor • Turn on Power and check operation noise. ▶ <u>If an abnormal noise show, replace Compressor.</u>
--



Check Point 2 : Check connection of around the Compressor components For Compressor Terminal, Main PCB • Check if connector is removed. • Check erroneous connection. • Check if cable is open. (Refer to PARTS INFORMATION 2) >> <u>Upon correcting the removed connector or mis-wiring, reset the power.</u>
--



Check Point 3: Replace Main PCB ▶ <u>If Check Point 1,2 do not improve the symptom, change Main PCB.</u>



Check Point 4: Replace Compressor ▶ <u>If Check Point 3 do not improve the symptom, change Compressor.</u>

Trouble shooting 21 OUTDOOR UNIT Error Method: Outdoor Unit Fan Motor Error	Indicate or Display: Outdoor Unit : No indication Indoor Unit : Operation lamp: 9 time Flash, Timer lamp: 7 time Flash Economy lamp: Continuous flash. ERROR CODE : [E : 97]
--	--

Detective Actuators: Outdoor unit Main PCB Outdoor unit Fan motor	Detective details: ① When outdoor fan rotation speed is less than 100rpm in 20 seconds after fan motor starts, fan motor stops. ② After fan motor restarts, if the same operation within 60sec is repeated 3 times in a row, compressor and fan motor stops. ③ If ① and ② repeats 5 times in a row, compressor and fan motor stops permanently.
--	---

Forecast of Cause:

1. Fan rotation failure 2. Motor protection by surrounding temperature rise 3. Main PCB failure
4. Outdoor unit fan motor

Check Point 1 : Check rotation of Fan

- Rotate the fan by hand when operation is off.
(Check if fan is caught, dropped off or locked motor)
>>If Fan or Bearing is abnormal, replace it.



Check Point 2 : Check ambient temp. around motor

- Check excessively high temperature around the motor.
(If there is any surrounding equipment that causes heat)
>>Upon the temperature coming down, restart operation.



Check Point 3 : Check Outdoor unit fan motor

- Check Outdoor unit fan motor. **(PARTS INFORMATION 5)**
>>If Outdoor unit fan motor is abnormal, replace Outdoor unit fan motor.



Check Point 4 : Check Output Voltage of Main PCB

- Check outdoor unit circuit diagram and the voltage. (Measure at Main PCB side connector)

Read wire	DC voltage
Red - Black	306-374V
White - Black	15 ± 1.5V

DC

► If the voltage is not correct, replace Main PCB.

Trouble shooting 22 OUTDOOR UNIT Error Method: 4-Way Valve Error	Indicate or Display: Outdoor Unit : No indication Indoor Unit : Operation lamp: 9 time Flash, Timer lamp: 9 time Flash Economy lamp: Continuous flash. ERROR CODE : [E : 99]
---	--

Detective Actuators: Indoor unit Main PCB Heat Ex. temperature thermistor Room temperature thermistor 4-way valve	Detective details: When the indoor heat exchanger temperature is compared with the room temperature, and either following condition is detected continuously two times, the compressor stops. <ul style="list-style-type: none"> ▪ Cooling or Dry operation [Indoor heat exchanger temp.] - [Room temp.] > 10degC ▪ Heating operation [Indoor heat exchanger temp.] - [room temp.] < - 10degC If the same operation is repeated 5 times, the compressor stops permanently.
--	--

Forecast of Cause : 1. Connector connection failure 2. Thermistor failure 3. Coil failure 4. 4-way valve failure 5. Main PCB failure

Check Point 1 : Check connection of Connector
<ul style="list-style-type: none"> ▪ Check if connector is removed. ▪ Check erroneous connection. ▪ Check if thermistor cable is open. >> Upon correcting the removed connector or mis-wiring, reset the power.



Check Point 2 : Check each thermistor
<ul style="list-style-type: none"> ▪ Isn't it fallen off the holder? ▪ Is there a cable pinched? >> Check characteristics of thermistor (Refer to Trouble shooting7,8) <u>If defective, replace the thermistor</u>



Check Point 3 : Check the solenoid coil and 4-way valve
[Solenoid coil] <ul style="list-style-type: none"> ▪ Remove P60 from PCB and check the resistance value of coil. Resistance value is 1.88kΩ ~ 2.29kΩ (at 20°C). >> If it is Open or abnormal resistance value, replace Solenoid Coil. [4-way valve] <ul style="list-style-type: none"> ▪ Check each piping temperature, and the location of the valve by the temperature difference. >> If the value location is not proper, replace 4-way valve.



Check Point 4 : Replace Main PCB
► If Check Point 1- 3 do not improve the symptom, replace Main PCB.

Trouble shooting 23 OUTDOOR UNIT Error Method: Discharge Temp. Error	Indicate or Display: Outdoor Unit : No indication Indoor Unit : Operation lamp: 10 time Flash, Timer lamp: 1 time Flash Economy lamp: Continuous flash. ERROR CODE : [E : A1]
---	--

Detective Actuators: Outdoor unit Main PCB Discharge temperature thermistor	Detective details: <ul style="list-style-type: none"> ▪ "Protection stop by "discharge temperature $\geq 110\text{degC}$ during compressor operation"" generated 2 times within 24 hours.
--	---

Forecast of Cause :	1. 3-way valve not opened 2. EEV defective, strainer clogged 3. Outdoor unit operation failure, foreign matter on heat exchanger 4. Discharge temperature thermistor failure 5. Insufficient refrigerant 6. Main PCB failure
----------------------------	---

<Cooling operation>

Check Point 1 : Check if 3-way valve(gas side) is open.
▪ If the 3-way valve(gas side) was closed, open the 3-way valve(gas side) and check operation.

OK

Check Point 2 : Check the EEV, strainer
▪ EEV (EEV2, indoor unit EEV) open? ▪ Strainer clogging check (before and after EEV, ACM oil return) Refer to "Service Parts Information 3".

OK

Check Point 3 : Check the outdoor unit fan,heat exchanger
▪ Check for foreign object at heat exchanger ▪ Check if fan can be rotated by hand. ▪ Motor check (PARTS INFORMATION 5)

OK

Check Point 4 : Check the discharge thermistor
▪ Discharger thermistor characteristics check. (Check by disconnecting thermistor from PCB.) * For the characteristics of the thermistor, refer to the "Trouble shooting 13".

OK

Check Point 5 : Check the refrigerant amount
▪ Leak check

<Heating operation>

Check Point 1 : Check if 3-way valve(liquid side) is open.
▪ If the 3-way valve(liquid side) was closed, open the 3-way valve(liquid side) and check operation.

OK

Check Point 2 : Check the EEV, strainer
▪ EEV (EEV1, EEV2) open? ▪ Strainer clogging check (before and after EEV, ACM oil return) Refer to "Service Parts Information 3".

OK

[24KLTA]

<p>Trouble shooting 24 OUTDOOR UNIT Error Method: Compressor Temp. Error</p>	<p>Indicate or Display: Outdoor Unit : No indication Indoor Unit : Operation lamp: 10 time Flash, Timer lamp: 3 time Flash Economy lamp: Continuous flash. ERROR CODE : [E : A3]</p>
---	--

<p>Detective Actuators: Compressor temperature thermistor</p>	<p>Detective details: ▪ "Protection stop by "compressor temperature" $\geq 110^{\circ}\text{C}$ during compressor operation""generated 2 times within 24 hours</p>
---	---

<p>Forecast of Cause :</p> <ol style="list-style-type: none"> 1. 3-way valve not opened 2. EEV defective, strainer clogged 3. Outdoor unit operation failure, foreign matter on heat exchanger 4. Compressor temperature thermistor failure 5. Insufficient refrigerant

<Cooling operation>

<p>Check Point 1 : Check if 3-way valve(gas side) is open.</p>
<p><input type="checkbox"/> If the 3-way valve(gas side) was closed, open the 3-way valve(gas side) and check operation.</p>

↓ OK

<p>Check Point 2 : Check the EEV, strainer</p>
<p><input type="checkbox"/> EEV open? <input type="checkbox"/> Strainer clogging check (before and after EEV, ACM oil return) Refer to "Service Parts Information 3".</p>

↓ OK

<p>Check Point 3 : Outdoor unit fan, heat exchanger check</p>
<p><input type="checkbox"/> Check for foreign object at heat exchanger <input type="checkbox"/> Check if fan can be rotated by hand. <input type="checkbox"/> Motor check(PARTS INFORMATION 5)</p>

↓ OK

<p>Check Point 4 : Check the compressor temperature thermistor</p>
<p><input type="checkbox"/> Compressor temperature thermistor characteristics check (Check by disconnecting thermistor from PCB Refer to the Troubleshooting 14)</p>

↓ OK

<p>Check Point 5 : Check the refrigerant amount</p>
<p><input type="checkbox"/> Leak check</p>

<Heating operation>

<p>Check Point 1 : Check if 3-way valve(liquid side) is open.</p>
<p><input type="checkbox"/> If the 3-way valve(liquid side) was closed, open the 3-way valve(liquid side) and check operation.</p>

↓ OK

<p>Check Point 2 : Check the EEV, strainer</p>
<p><input type="checkbox"/> EEV open? <input type="checkbox"/> Strainer clogging check (before and after EEV, ACM oil return) Refer to "Service Parts Information 3 "</p>

↙ OK

2-3 TROUBLE SHOOTING WITH NO ERROR CODE

Trouble shooting 25

Indoor Unit - No Power

Forecast of Cause:

1. Power supply failure
2. External cause
3. Electrical components defective

Check Point 1 : Check Installation Condition

- Isn't the breaker down?
- Check loose or removed connection cable.
- >> **If abnormal condition is found, correct it by referring to Installation Manual or Data & Technical Manual.**

OK

Check Point 2 : Check external cause at Indoor and Outdoor (Voltage drop or Noise)

- Instant drop ----- Check if there is a large load electric apparatus in the same circuit.
- Momentary power failure ----- Check if there is a defective contact or leak current in the power supply circuit.
- Noise ----- Check if there is any equipment causing harmonic wave near electric line. (Neon bulb or electric equipment that may cause harmonic wave)
Check the complete insulation of grounding.

OK

Check Point 3 : Check Electrical Components

- Check the voltage of power supply.
- >> **Check if AC207 - 253V appears at Outdoor Unit Terminal L - N.**

YES

- Check Fuse in Main PCB.
- >> **If Fuse is open, check if the wiring between Terminal and Main PCB is loose, and replace Fuse.**
- Check Varistor in Main PCB.
- >> **If Varistor is defective, there is a possibility of an abnormal power supply. Check the correct power supply and replace Varistor. Upon checking the normal power supply, replace Varistor.**



NO

Trouble shooting 26

Outdoor Unit - No Power

Forecast of Cause:

1. Power supply failure
2. External cause
3. Electrical Components defective

Check Point 1 : Check Installation Condition

- Isn't the breaker down?
- Check loose or removed connection cable.
- >> **If abnormal condition is found, correct it by referring to Installation Manual or Data & Technical Manual.**

OK

Check Point 2 : Check external cause at Indoor and Outdoor (Voltage drop or Noise)

- Instant drop ----- Check if there is a large load electric apparatus in the same circuit.
- Momentary power failure ----- Check if there is a defective contact or leak current in the power supply circuit.
- Noise ----- Check if there is any equipment causing harmonic wave near electric line.
(Neon bulb or electric equipment that may cause harmonic wave)
Check the complete insulation of grounding.

OK

Check Point 3 : Check Electrical Components

- Check the voltage of power supply.
- >> **Check if AC207 - 253V appears at Outdoor Unit Terminal L - N.**

YES

- Check Fuse in Main PCB.
- >> **If Fuse is open, check if the wiring between Terminal and Main PCB is loose, and replace Fuse.**
- Check Varistor in Main PCB.
- >> **If Varistor is defective, there is a possibility of an abnormal power supply. Check the correct power supply and replace Varistor. Upon checking the normal power supply, replace Varistor.**

OK

► **If the symptom does not change by above Check 3, replace Main PCB.**

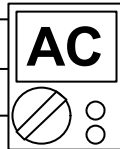

NO

Trouble shooting 27

No Operation (Power is ON)

Forecast of Cause:

1. Setting/ Connection failure
2. External cause
3. Electrical Component defective

Check Point 1 : Check indoor and outdoor installation condition

- Indoor Unit - Check incorrect wiring between Indoor Unit - Remote Control.
Or, check if there is an open cable connection.
- Are these Indoor Unit, Outdoor Unit, and Remote Control suitable model numbers to connect?
>> **If there is some abnormal condition, correct it by referring to Installation manual and Data & Technical Manual.**

↓ OK

Turn off Power and check/ correct followings.

- Is there loose or removed communication line of Indoor Unit and Outdoor Unit?

↓ OK

Check Point 2 : Check external cause at Indoor and Outdoor (Voltage drop or Noise)

- Instant drop ----- Check if there is a large load electric apparatus in the same circuit.
- Momentary power failure ----- Check if there is a defective contact or leak current in the power supply circuit.
- Noise ----- Check if there is any equipment causing harmonic wave near electric line.
(Neon bulb or electric equipment that may cause harmonic wave)
Check the complete insulation of grounding.

Trouble shooting 28

No Cooling / No Heating

Forecast of Cause:

1. Indoor Unit error
2. Outdoor Unit error
3. Effect by surrounding environment
4. Connection pipe / Connection wire failure
5. Refrigeration cycle failure

Check Point 1 : Check Indoor unit

- Does Indoor unit Fan run on High fan?
- Is Air filter dirty?
- Is Heat exchanger clogged?
- Check if Energy save function is operated.



Check Point 2 : Check Outdoor unit operation

- Check if Outdoor unit is operating
- Check any objects that obstruct the air flow route.
- Check clogged Heat Exchanger.
- Is the Valve open?



Check Point 3 : Check Site condition

- Is capacity of Indoor unit fitted to room size?
- Any windows open? or direct sunlight ?



Check Point 4 : Check Indoor/ Outdoor installation condition

- Check connection pipe (specified pipe length & Pipe diameter?)
- Check any loose or removed communication line.
- >> **If there is an abnormal condition, correct it by referring to Installation Manual or Data & Technical Manual.**



Check Point 5 : Check Refrigeration cycle

- Check if Strainer is clogged (Refer to the figure at right).
- Measure Gas Pressure and if there is a leakage, correct it.
- >> **When recharging the refrigerant, make sure to perform vacuuming, and recharge the specified amount.**
- Check EEV (PARTS INFORMATION 3)
- Check Compressor (PARTS INFORMATION 1,2)

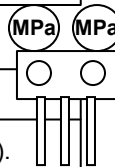

Attention

Strainer normally does not have temperature difference between inlet and outlet as shown in ①, but if there is a difference like shown in ②, there is a possibility of inside clogged. In this case, replace Strainer.

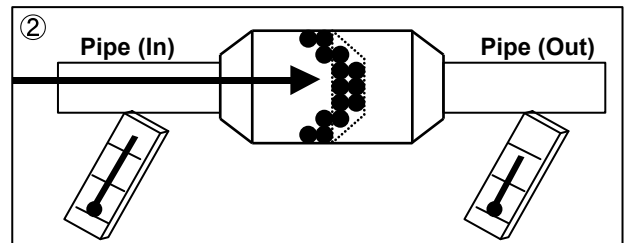
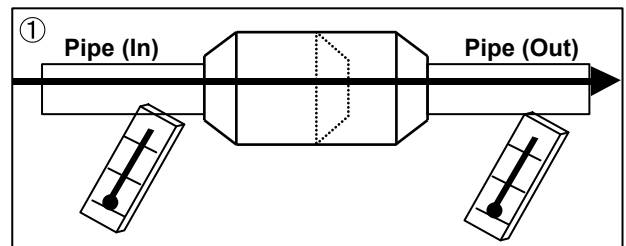

Trouble shooting 29
Abnormal Noise

- Forecast of Cause :
1. Abnormal installation (Indoor/ Outdoor)
 2. Fan failure (Indoor/ Outdoor)
 3. Compressor failure (Outdoor)

Diagnosis method when abnormal noise is occurred

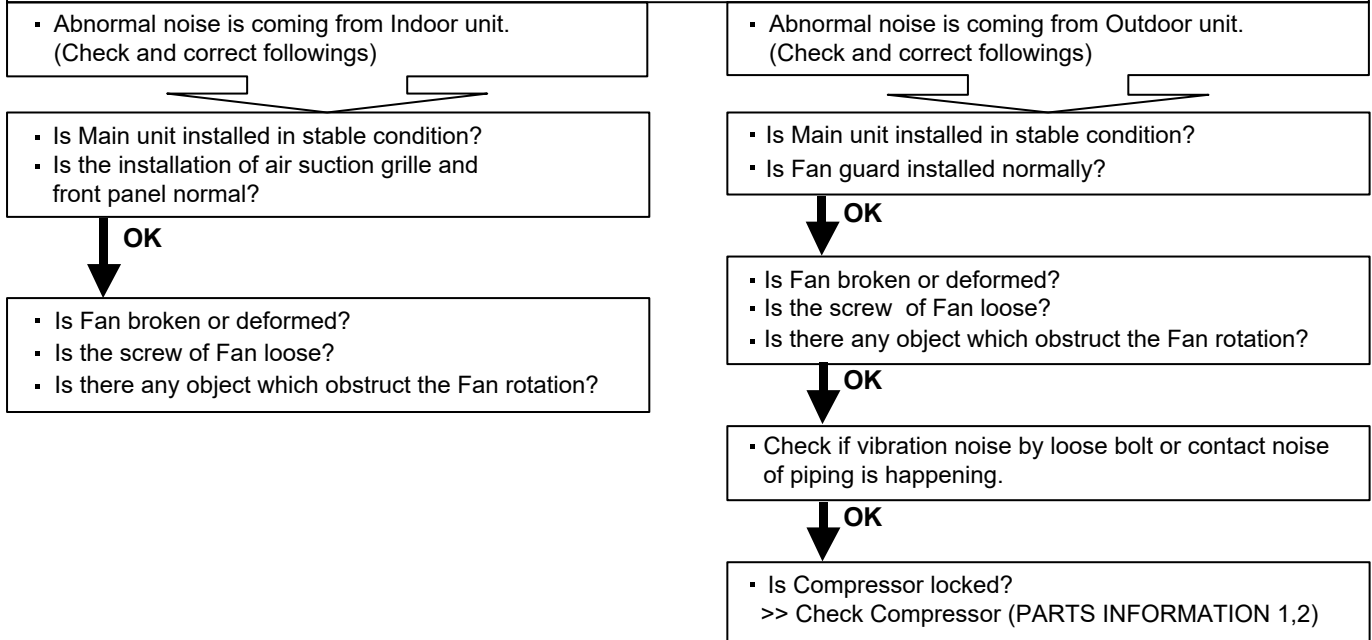

Trouble shooting 30
Water Leaking

- Forecast of Cause:
1. Erroneous installation
 2. Drain hose failure

Diagnosis method when water leak occurs

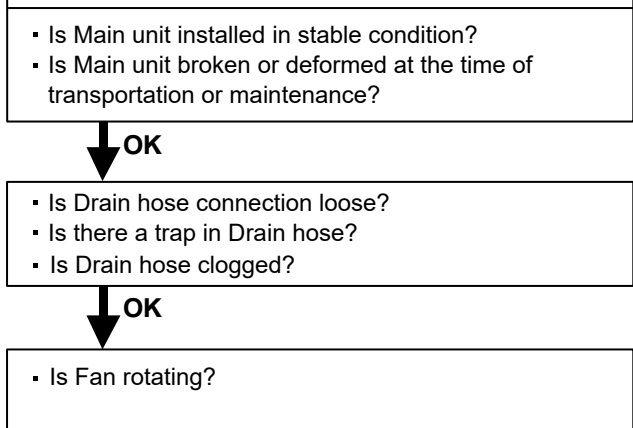

Diagnosis method when water is spitting out.

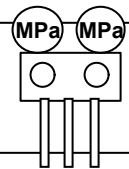
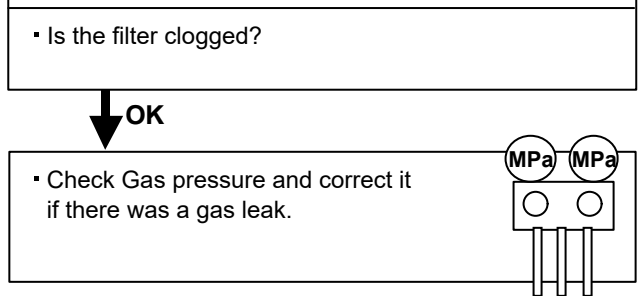

2-4 SERVICE PARTS INFORMATION

SERVICE PARTS INFORMATION 1

Compressor

Diagnosis method of Compressor (If Outdoor Unit LED displays Error, refer to Trouble shooting)

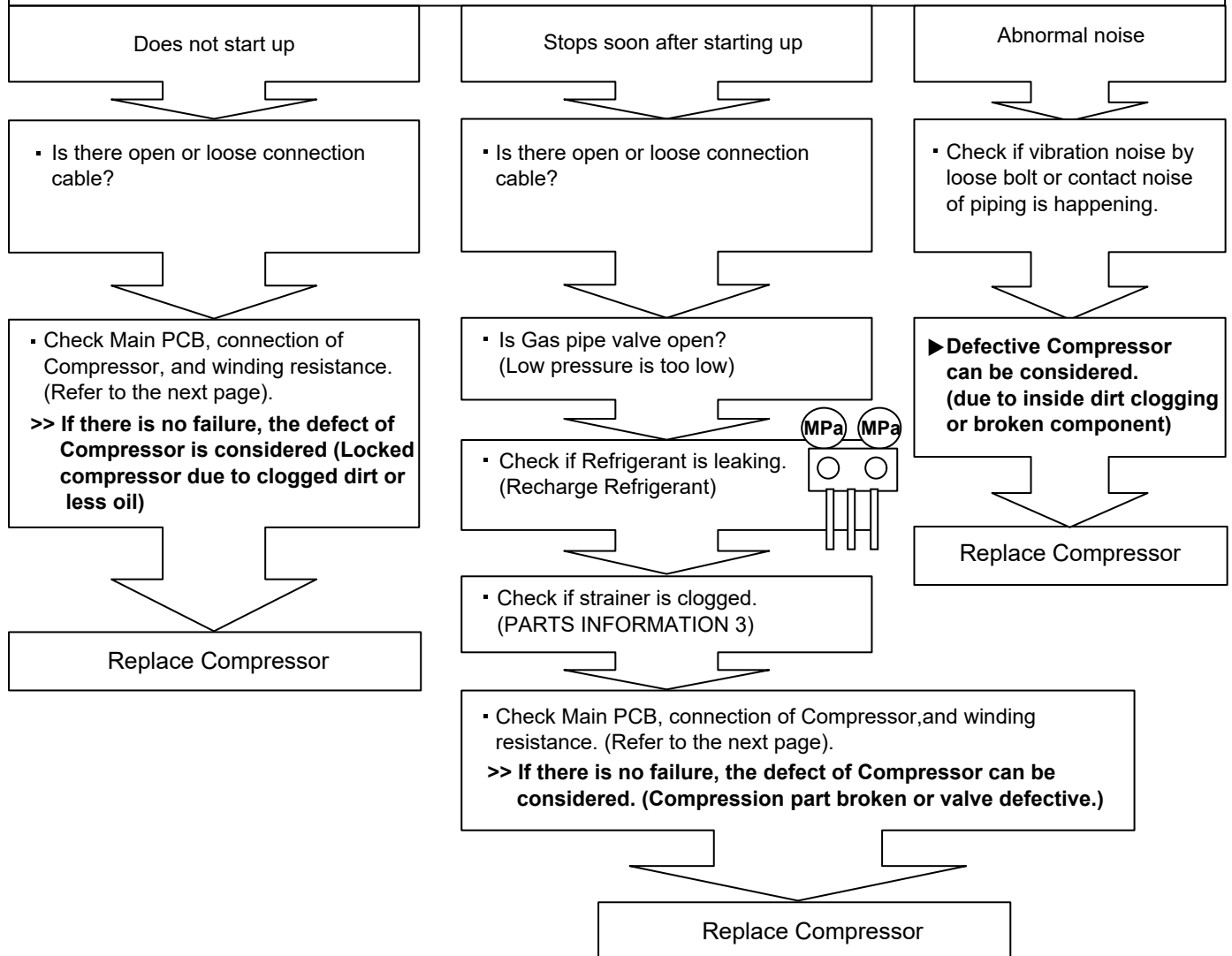

SERVICE PARTS INFORMATION 2

Inverter Compressor

Check Point 1 : Check Connection

- Check terminal connection of Compressor (loose or incorrect wiring)

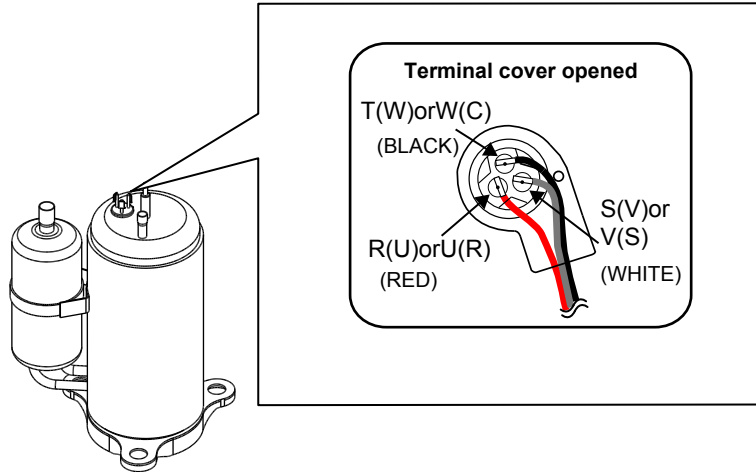

Check Point 2 : Check Winding Resistance

- Check winding resistance of each terminal

► **If the resistance value is 0 Ω or infinite, replace Compressor.**

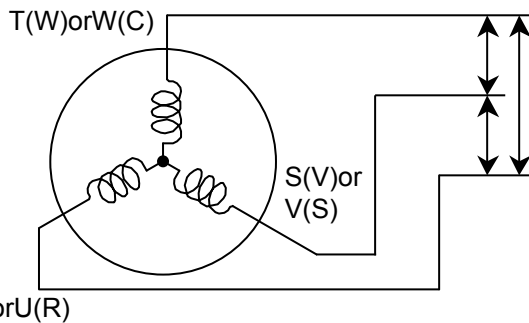

Resistance Value :

T(W)-S(V), T(W)-R(U), S(V)-R(U)
1.910 Ω at 20°C for 18KLTA

W(C)-V(S), W(C)-U(R), V(S)-U(R)
1.916 Ω at 20°C for 24KLTA

Check Point 3 : Replace Main PCB

► **If the symptom does not change with above Check 1, 2, replace Main PCB.**

SERVICE PARTS INFORMATION 3

Outdoor unit Electronic Expansion Valve (EEV)

Check Point 1 : Check Connections

- Check connection of connector (P30)
(Loose connector or open cable)

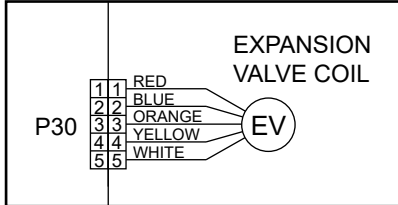

Check Point 2 : Check Coil of EEV

- Remove connector, check each winding resistance of Coil.

Read wire	Resistance value
White - Red	$46 \Omega \pm 4 \Omega$ at 20°C
Yellow - Red	
Orange - Red	
Blue - Red	

► **If Resistance value is abnormal, replace EEV.**

Check Point 3 : Check Voltage from Main PCB.

- Remove Connector and check Voltage (DC12V)

► **If it does not appear, replace Main PCB.**



Check Point 4 : Check Noise at start up

- Turn on Power and check operation noise.

► **If an abnormal noise does not show, replace Main PCB.**

Check Point 5 : Check Opening and Closing Operation of Valve

When Valve is closed, it has a temp. difference between Inlet and Outlet.

CLOSE
Example : Hot Gas

Pipe (In)
Hi TEMP.

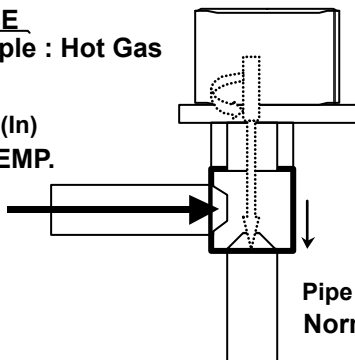

If it is open, it has no temp. difference between Inlet and Outlet.

OPEN
Example : Hot Gas

Pipe (In)
Hi TEMP.

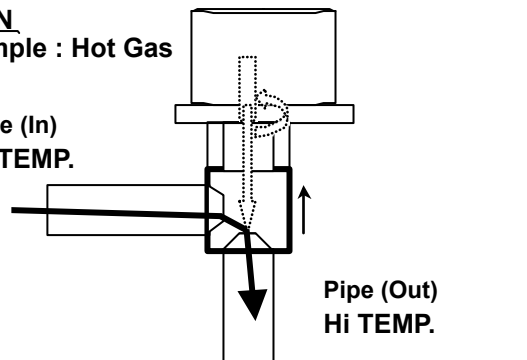

Check Point 6 : Check Strainer

Strainer normally does not have temperature difference between inlet and outlet as shown in ①, but if there is a difference as shown in ②, there is a possibility of inside clogged. In this case, replace Strainer.

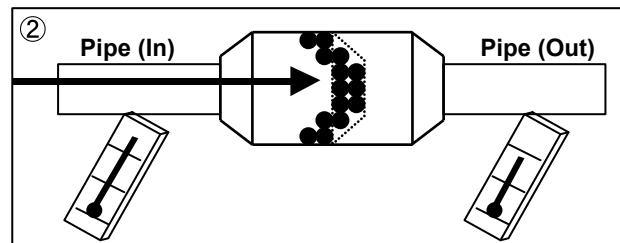
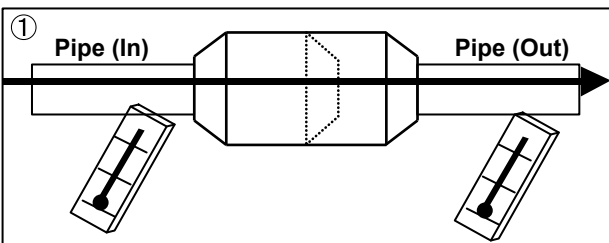

SERVICE PARTS INFORMATION 4

Indoor unit fan motor

Check Point 1 : Check rotation of Fan

- Rotate the fan by hand when operation is off.
(Check if fan is caught, dropped off or locked motor)
- >>If Fan or Bearing is abnormal, replace it.**

Check Point 2 : Check resistance of Indoor Fan Motor

- Refer to below. Circuit-test "Vm" and "GND" terminal.
(Vm: DC voltage, GND: Earth terminal)
- >>If they are short-circuited (below 300 k Ω), replace Indoor fan motor and Main PCB.**

Pin number (wire color)	Terminal function (symbol)
1 (Blue)	Feed back (PG)
2 (Yellow)	Speed command (Vsp)
3 (White)	Control voltage (Vcc)
4 (Black)	Earth terminal (GND)
5	No function
6 (Red)	DC voltage (Vm)

SERVICE PARTS INFORMATION 5

Outdoor unit fan motor

Check Point 1 : Check rotation of Fan

- Rotate the fan by hand when operation is off.
(Check if fan is caught, dropped off or locked motor)
- >>If Fan or Bearing is abnormal, replace it.**

Check Point 2 : Check resistance of Outdoor Fan Motor

- Refer to below. Circuit-test "Vm" and "GND" terminal.
(Vm: DC voltage, GND: Earth terminal)
- >>If they are short-circuited (below 300 k Ω), replace Outdoor fan motor and Main PCB.**

Pin number (wire color)	Terminal function (symbol)
1 (Red)	DC voltage (Vm)
2	No function
3	No function
4 (Black)	Earth terminal (GND)
5 (White)	Control voltage (Vcc)
6 (Yellow)	Speed command (Vsp)
7 (Brown)	Feed back (FG)

WALL MOUNTED type INVERTER

3 . APPENDING DATA

3-1. FUNCTION SETTING

3-1-1 INDOOR UNIT

Remote controller address setting

* Because this setting is normally done automatically when 2-wire-type wired remote controller is installed, setting is unnecessary.

Multiple indoor units can be operated by using one wired remote controller.
Set the unit number of each indoor unit.

Function Number	Setting Value	setting Description	Factory setting
00	00	Unit no.0	◆
	01	Unit no.1	
	02	Unit no.2	
	03	Unit no.3	
	04	Unit no.4	
	05	Unit no.5	
	06	Unit no.6	
	07	Unit no.7	
	08	Unit no.8	
	09	Unit no.9	
	10	Unit no.10	
	11	Unit no.11	
	12	Unit no.12	
	13	Unit no.13	
	14	Unit no.14	
	15	Unit no.15	

*When connecting Polar 3-core wired remote controller, set the remote controller address in the order of 0, 1, 2,, and 15.

*When different type of indoor units (such as wall-mounted type and cassette type, cassette type and duct type, or other combinations) are connected using group control system, some functions may no longer be available.

Filter sign

Select appropriate intervals for displaying the filter sign on the indoor unit according to the estimated amount of dust in the air of the room.

If the indication is not required, select "No indication" (03).

Function Number	Setting Value	Setting Description	Factory setting
11	00	Standard (400 hours)	
	01	Long interval (1,000 hours)	
	02	Short interval (200 hours)	
	03	No indication	◆

Room temperature control for indoor unit sensor

Depending on the installed environment, correction of the room temperature sensor may be required. Select the appropriate control setting according to the installed environment.

The temperature correction values show the difference from the Standard setting "00" (manufacturer's recommended value).

Function number		Setting value	Setting description	Factory setting	
30 (For cooling)	31 (For heating)	00	Standard setting	◆	
		01	No correction 0.0 °C		
		02	-0.5 °C	More cooling Less heating	
		03	-1.0 °C		
		04	-1.5 °C		
		05	-2.0 °C		
		06	-2.5 °C		
		07	-3.0 °C		
		08	-3.5 °C		
		09	-4.0 °C		
		10	+0.5 °C	Less cooling More heating	
		11	+1.0 °C		
		12	+1.5 °C		
		13	+2.0 °C		
		14	+2.5 °C		
		15	+3.0 °C		
		16	+3.5 °C		
17	+4.0 °C				

Auto restart

Enables or disables automatic restart after a power interruption.

Function number	Setting value	Setting description	Factory setting
40	00	Enable	◆
	01	Disable	

*Auto restart is an emergency function such as for power outage etc. Do not attempt to use this function in normal operation. Be sure to operate the unit by remote controller or external device.

Remote controller custom code

(Only for wireless remote controller)

The indoor unit custom code can be changed. Select the appropriate custom code.

Function number	Setting value	Setting description	Factory setting
44	00	A	◆
	01	B	
	02	C	
	03	D	

Indoor unit fan control for energy saving for cooling

Enables or disables the power-saving function by controlling the indoor unit fan rotation when the outdoor unit is stopped during cooling operation.

Function number	Setting value	Setting description	Factory setting
49	00	Disable	
	01	Enable	◆
	02	Remote controller	

00: When the outdoor unit is stopped, the indoor unit fan operates continuously following the setting on the remote controller.

01: When the outdoor unit is stopped, the indoor unit fan operates intermittently at a very low speed.

02: Enable or disable this function by remote controller setting.

As the factory setting, this setting is initially invalidated.

- When connecting VRF system using network converter, this setting must be set to "00" or "01".

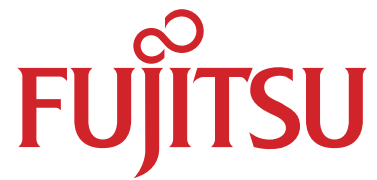

FUJITSU GENERAL LIMITED

3-3-17, Suenaga, Takatsu-ku, Kawasaki 213-8502, Japan