

EMICON

INNOVATION AS ENERGY



AN ENEX TECHNOLOGIES COMPANY

PAE Kp/ PAE WA Kp- GPE kp AIR COOLED MULTIFUNCTION UNITS FOR 4-PIPE SYSTEMS FOR OUTDOOR INSTALLATION WITH SEMIHERMETIC RECIPROCATED COMPRESSORS AND AXIAL FANS



INSTALLATION, USE AND MAINTENANCE TECHNICAL MANUAL

Incorporated in this document are the following:

- Declaration of conformity
- Technical manual
- Dimensional drawing



RETAIN FOR FUTURE REFERENCE



Multiple instructions:
Consult the specific part



Read and understand
the instructions before
undertaking any work on
the unit

Reproduction, data storage and transmission, even partial, of this publication, in any form, without the prior written authorisation of the Company, is prohibited. The Company can be contacted for all inquiries regarding the use of its products.

The Company follows a policy of continuous product development and improvement and reserves the right to modify specifications, equipment and instructions regarding use and maintenance at any time, without notice.

Declaration of conformity

We declare under our own responsibility that the below equipment complies in all parts with the CEE and EN directives.

The declaration of conformity is enclosed to the documentation with the unit.

INDEX

1. INTRODUCTION	5
1.1 Preliminary information	5
1.2 Aim and content of the manual	5
1.3 How to store this manual	5
1.4 Manual updates	5
1.5 How to use this manual	5
1.6 Potential risks	6
1.7 General description of symbols used	7
1.8 Safety symbols used	8
1.9 Glossary	8
1.10 Limitations and prohibited use	8
1.11 Unit identification	9
2. SAFETY	10
2.1 Warning re potentially hazardous toxic substances	10
2.2 Refrigerant handling	12
2.3 Prevention inhalation of high vapor concentrations	12
2.4 Procedures to be adopted in the event of accidental release of refrigerant	12
2.5 Main Toxicological Information Regarding the Type of refrigerant used	12
2.6 First aid measures	12
3. TECHNICAL CHARACTERISTICS	13
3.1 Unit description	13
3.2 Other versions	15
3.3 Options	16
3.4 Technical data	18
3.5 Operation limits	24
3.6 Correction tables	26
3.7 Sound data	26
4. INSTALLATION	27
4.1 General safety guidelines and use of symbols	27
4.2 Health and safety Considerations	27
4.3 Personal protective equipment	27
4.4 Inspection	28
4.5 Transport and handling	28
4.6 Storage	29
4.7 Unpacking	29
4.8 Lifting and handling	30
4.9 Location and minimum technical clearances	31
4.10 Hydraulic connections	33
4.11 Hydraulic circuit	35
4.12 Chemical characteristics of the water	36
4.13 User circuit minimum water content	37
4.14 Filling the hydraulic circuit	37
4.15 Emptying the installation	37
4.16 Wiring connections: Preliminary safety information	38
4.17 Connection of mains cables between multiple units	40
4.18 Electric data	42
5. UNIT START UP	43
5.1 Preliminary Checks	43
5.2 Safety valves	45
5.3 Description of the control panel	46
6. USE	47
6.1 Quick menu	47
6.2 ON / OFF Display	47
6.3 Info menu	47
6.4 Set point	49

6.5 Everest: synoptic of the modular system	50
6.6 Access to the main menu	51
6.7 Time bands	52
6.8 Second Set Point from ID	53
6.9 I/O	54
6.10 Module control functions	56
6.11 Multi-element control functions	57
7. MAINTENANCE OF THE UNIT	59
7.1 General warnings	59
7.2 Drive access	60
7.3 Routine maintenance	61
7.4 Exceptional Maintenance	61
7.5 Periodical checks	64
7.6 Refrigerant circuit repair	67
8. DECOMMISSIONING	68
8.1 Disconnect the unit	68
8.2 Disposal, recovery and recycling	68
8.3 RAEE directive (only for EC countries)	68
9. DIMENSIONAL DRAWINGS	69

1. INTRODUCTION

1.1 Preliminary information

Reproduction, storage or transmission of any part of this publication in any form, without the prior written consent of the Company, is prohibited.

The unit to which these instructions refer, is designed to be used for the the purposes described and to be operated in accordance with these instructions.

The Company will not be liable for claims for damage caused to persons, animals, material goods or property caused by improper installation, adjustment and maintenance or improper use. Any use not specified in this manual is prohibited.

This document is intended to provide information only and does not form a contract with third parties.

The Company pursues a policy of constant improvement and development of its products and therefore reserves the right to change the specifications and the documentation at any time, without notice and without obligation to update existing equipment.

1.2 Aim and content of the manual

These instructions are intended to provide the information required for the selection, installation, use and maintenance of the unit.

They have been prepared in accordance with the European Union laws and with the technical standards in force at the date of issue of the instructions.

The instructions contain all the necessary information to prevent any reasonably foreseeable misuse.

1.3 How to store this manual

The manual must be kept in a suitable place with easy access for users and operators, protected from dust and damp.

The manual must always accompany the unit during the entire life cycle of the same and therefore must be transferred to any subsequent user.

1.4 Manual Update

It is recommended that the manual is updated to the latest revision available.

If updates are sent to the customer they must be added to this manual.

The latest information regarding the use of its products is available by contacting the Company.

1.5 How to use this manual



The manual is an integral part of the unit.



Users or operators must consult the manual before performing any operation and especially so when transporting, handling, installing, maintaining, or dismantling the unit in order to eliminate uncertainty and reduce risk.

In these instructions symbols have been used (described in the following paragraphs) to draw the attention of operators and users to the operations that have a higher risk and which must be performed safely.

1.6 Potential Risks

Whilst the unit has been designed to minimize any risk posed to the safety of people who will interact with it, it has not been technically possible to eliminate completely the causes of risk. It is therefore necessary to refer to the requirements and symbolism below:

LOCATION OF RISK	POTENTIAL RISK	METHOD OF INJURY	PRECAUTIONS
Thermal heat exchangers.	Small stab wounds.	Contact	Avoid any contact, use protective gloves.
Fan and fan grilles.	Cuts, eye damage, broken bones.	Insertion of sharp objects through the grid while the fans are operating.	Never put objects through the protection grilles.
Internal component: compressors and discharge pipes	Burns.	Contact	Avoid any contact, use protective gloves.
Internal component: electric cables and metallic parts	Electrocution, severe burns.	Defect in the supply cable insulation, live metallic parts.	Adequate protection of power cables, ensure correct earthing of all metal parts.
External to unit: unit enclosure	Poisoning, severe burns.	Fire due to short circuit or overheating of the supply cable external to unit.	Size cables and mains protection system in accordance with iee regulations.
Low pressure safety valve. (if present)	Poisoning, severe burns.	High evaporating pressure causing a refrigerant discharge during maintenance.	Carefully check the evaporating pressure during the maintenance operations.
High pressure safety valve. (if present)	Poisoning, severe burns, hearing loss.	Activation of the high pressure safety valve.	If possible, do not open the refrigerant circuit valve; carefully check the condensing pressure; use all the personal protective equipment required by law.
Entire unit	External fire	Fire due to natural disasters or combustions of elements nearby unit	Provide the necessary fire-fighting equipment
Entire unit	Explosion, injuries, burns, poisoning, folgoramento for natural disasters or earthquake.	Breakages, failures due to natural disasters or earthquake	Plan the necessary precautions both electrical (suitable differential magneto and electrical protection of the supply lines; greatest care during the connections of the metal parts), and mechanical (special anchors or seismic vibrations to prevent breakages or accidental falls).

1.7 General Description of Symbols Used

Safety symbols combined in accordance with ISO 3864-2:



BANNED

A black symbol inside a red circle with a red diagonal indicates an action that should not be performed.



WARNING

A black graphic symbol added to a yellow triangle with black edges indicates danger.



ACTION REQUIRED

A white symbol inserted in a blue circle indicates an action that must be done to avoid a risk.

Safety symbols combined in accordance with ISO 3864-2:



The graphic symbol "warning" is qualified with additional safety information (text or other symbols).

1.8 Safety symbols used



GENERAL RISK

Observe all signs placed next to the pictogram. The failure to follow directions may create a risk situation that may be injurious to the user.



ELECTRICAL HAZARD

Observe all signs placed next to the pictogram. The symbol indicates components of the unit and actions described in this manual that could create an electrical hazard.



MOVING PARTS

The symbol indicates those moving parts of the unit that could create risk.



HOT SURFACES

The symbol indicates those components with high surface temperature that could create risks.



SHARP SURFACES

The symbol indicates components or parts that could cause stab wounds.



EARTH CONNECTION

The symbol identifies Earthing connection points in the unit.



READ AND UNDERSTAND THE INSTRUCTIONS

Read and understand the instructions of the machine before any operations.



RECOVER OR RECYCLE MATERIAL

1.9 Glossary

Within this manual it is indicated with:

Machine/Unit: a single module

Modular system: a group of 2 or more modules (up to 10) operating on a single hydronic circuit.

Warnings, prohibitions or instructions contained in the manual and referring to the unit are also extended to modular systems or vice-versa.

1.10 Limitations and prohibited use

The machine is designed and built exclusively for the uses described in "Limitations of use" of the technical manual.

Any other use is prohibited because it may pose a potential risk to the health of operators and users.



The unit is not suitable for operations in environments:

- excessively dusty or potentially explosive atmospheres;
- where there are vibrations;
- where there are electromagnetic fields;
- where there are aggressive atmospheres

1.11 Unit identification

Each unit has a rating plate that provides key information regarding the machine. The rating plate may differ from the one shown below as the example is for a standard unit without accessories. For all electrical information not provided on the label, refer to the wiring diagram. A facsimile of the label is shown below:

TEL.+39 0543495611 FAX+39 0543 495612 Via A.Volta 49 Meldola FC ITALY		NB 0948							
MODELLO MODEL MODÈLE MODEL		ANNO DI COSTRUZIONE / PED CATEGORY MANUFACTURE YEAR / PED CATEGORY JAHR VON KONSTRUKT / PED KATEGORIE ANNÉE DE FABRICAT / CATÉGORIE PED	2019 CAT						
MATRICOLA SERIAL NR N° DE SÉRIE STAMM NR		CORRENTE MAX. MAX CURRENT INPUT MAXIMALEN STROM AMPÈRES MAXIMALE	A						
ALIMENTAZIONE ELET. SUPPLY VOLTAGE ALIMENTATION ELECT. SPANNUNG	400V+10%-50Hz+12%-3PH-GND	ASSORBIMENTO ELETTRICO NOMINALE PUISSANCE ÉLECTRIQUE NOMINALE NOMINAL ABSORBED POWER NOMINALELEISTUNGSAUFNAHME	kW						
GAS REFRIGERANTE REFRIGERANT RéFRIGÉRANT KALTEMITTEL	R290 / 3,3	CORRENTE CORTO CIRCUITO SHORT CIRCUIT CURRENT COURANT COURT-CIRCUIT STROM KURZSCHLUSS	kA 10						
CARICA REFRIGERANTE REFRIGERANT CHARGE KALTEMITTEL CHARGE FRIGORIGÈNE	<table border="1"> <tr> <td>C1</td> <td>C2</td> <td>kg.</td> </tr> <tr> <td>C1</td> <td>C2</td> <td>CO2 Ton</td> </tr> </table>	C1	C2	kg.	C1	C2	CO2 Ton	PESO OPERATIVO OPERATING WEIGHT POIDS OPERATION. ARBEITSGEWICHT	kg.
C1	C2	kg.							
C1	C2	CO2 Ton							
LATO BASSA PRESSIONE / LOW PRESSURE SIDE CIRCUIT BASSE PRESSION / NIEDERDRÜCKSEITE		LATO ALTA PRESSIONE / HIGH PRESSURE SIDE CIRCUIT HAUTE PRESSION / HOCHDRÜCKSEITE							
PRESSIONE DI PROGETTO DESING PRESSURE PRESSION DE PROJET DRUCK DES PROJEKTES	-- Bar	PRESSIONE DI PROGETTO PS DESING PRESSURE PS PRESSION DE PROJET PS DRUCK DES PROJEKTES PS	-- Bar						
TEMP.MIN PROGETTO MINI DESING TEMPERATURE KLEINSTE TEMP.DES PROJEKTES TEMP.MOINORE DE PROJET	- 30 °C	TEMP.MIN PROGETTO MINI DESING TEMPERATURE KLEINSTE TEMP.DES PROJEKTES TEMP.MOINORE DE PROJET	- 10 °C						
MAX TEMPERATURA PROGETTO MAX DESING TEMPERATURE MAXIMALE TEMP.DES PROJEKTES MAXIMUM TEMP DE PROJET	+ 54 °C	MAX TEMPERATURA PROGETTO MAX DESING TEMPERATURE MAXIMALE TEMP.DES PROJEKTES MAXIMUM TEMP DE PROJET	+110 GAS + 65 LIQU °C						
TARATURA ORGANO SICUREZZA SETTING OF SAFETY DEVISE MISE AU POINT DISPOSITIF DE SECURITÉ EINSTELLWERT ICHERHEITSELEMENT		-- Bar							



The product label should never be removed from the unit.

2. SAFETY

2.1 Warning on potentially dangerous toxic substances

2.1.1 Identification of the used fluid: R290 (Propane)



WARNING!

The refrigerante R290 (PROPANE) is flammable and it must be handled only by competent and responsible operators, under the conditions specified in the safety regulations in force.



DO NOT SMOKE

NO NAKED FLAMES

The refrigerant used is Propane (R290). In compliance with 2014/68/EU directive (hereafter: PED), this substance is considered a gas (PED, art. 13) of Group 1 which contains the dangerous fluids (extremely flammable). According EN 378-1, att. F, Propane is classified as a Group 3 substance (low toxicity, high flammability).

Safety information of this refrigerant are listed in the following table

Nome chimico	Propano
Designazione (ISO 817)	R290
Formula chimica	C ₃ H ₈
Gruppo di sicurezza (EN378-1)	A3
Classificazione PED	Group 1 Gas
Limite inferiore di infiammabilità (LFL)	0,038 kg/m ³ – 2,1% m ³ /m ³ ()
Limite superiore di infiammabilità (UFL)	0,177 kg/m ³ – 9,8% m ³ /m ³ (1)
Densità del vapore (a 25°C, 101,3 kPa)	1,832 kg/m ³
Densità relativa	1,56
Massa molecolare	44 kg/kmol
Punto di ebollizione normale	-42°C
Temperatura di autoaccensione	470°C
Temperatura di infiammabilità	-104°C
Potenziale di riduzione dell'ozono (ODP)	0
Potenziale di riscaldamento globale (GWP - orizzonte temporale di 100 anni)	3 (CO ₂ = 1)

Note that Propane has a higher density than the air one, therefore in case of leaks, it will tend to flow down

CHEMICAL COMPOSITION OF PROPAN USED AS A REFRIGERANT:

Refrigerant content ≥ 99,5% by mass
 Organic impurities ≤ 0,5% by mass

1,3 Butadiene (for each single unsaturated multiple hydrocarbon)	≤ 5 ppm in mass
Normal Hexane	≤ 50 ppm in mass
Benzene (for each aromatic mixture)	≤ 1 ppm in mass
Sulfur	≤ 2 ppm in mass
Non-condensable gases	≤ 1,5% in volume della fase vapore
Water	≤ 25 ppm in mass
Acid content	≤ 0,02 mg KOH/g per la neutralizzazione
Evaporation residue	≤ 50 ppm in mass
Particles / solids	Nessuno (ispezione visiva)
Evaporating temperature glide	≤ 0,5 K
Practical limit (EN378-1, all.F)	0,008 kg/m ³
Acute Toxicity Exposure Limit (ATEL) / O2 Deprivation Limit	0,09 kg/m ³

Propane highlights compatibility problems with some rubber or plastic types, particularly if chlorinated. Tests on critical materials will be required.

2.1.2 Identification of the Type of Oil Used.

The lubricant used is polyester oil. Please refer to the information provided on the compressor data plate.



For further information regarding the characteristics of the refrigerant and oil used, refer to the safety data sheets available from the refrigerant and oil manufacturers and attached in this manual.

Main Ecological Information Regarding the Types of refrigerants Fluids used.



ENVIRONMENTAL PROTECTION : Read the ecological information and the following instructions carefully.

2.1.3 Effects of discharges

Discharges into the atmosphere of this product does not cause a long-term contamination.

2.1.4 Exposure controls and personal protection

Wear protective clothing and gloves, protect your eyes and face

2.1.5 Professional exposure limits

Limit values TLV-TWA: 2500 ppm

2.2 Refrigerant handling



Users and maintenance personnel must be adequately informed about the possible risks of handling potentially toxic substances. Failure to follow such instructions can cause damage to personnel or to the unit.

2.3 Prevent inhalation of high vapor concentration

Atmospheric concentrations of refrigerant must be minimized and kept to a level that is below the occupational exposure limit. Vapor is heavier than air and can form dangerous concentrations near the ground where the ventilation rate is lower. Always ensure adequate ventilation. Avoid contact with open flames and hot surfaces as this can cause toxic and irritating decomposition products to form. Avoid contact between liquid refrigerant and the eyes or skin.

2.4 Procedures to be adopted in the event of accidental release of refrigerant

Ensure suitable personal protection (especially respiratory protection) during cleaning operations.

If deemed safe, isolate the source of the leak. If the leakage is small and if adequate ventilation is provided, allow the refrigerant to evaporate. If the loss is substantial ensure that measures are taken to adequately ventilate the area.

Contain spilled material with sand, earth or other suitable absorbent material.

Do not allow the refrigerant to enter drains, sewers or basements, as pockets of vapor can form.

2.5 Main Toxicological Information Regarding the Type of refrigerant used

2.5.1 Inhalation

A high atmospheric concentration can cause anaesthetic effects with possible loss of consciousness. Prolonged exposure may lead to irregular heartbeat and cause sudden death. Higher concentrations may cause asphyxia due to the reduced oxygen content in the atmosphere.

2.5.2 Contact with skin

Splashes of nebulous liquid can produce frostbite. Probably not hazardous if absorbed through the skin. Repeated or prolonged contact may remove the skin's natural oils, with consequent dryness, cracking and dermatitis.

2.5.3 Contact with eyes

Splashes of liquid may cause frostbite.

2.5.4 Ingestion

While highly improbable, may produce frostbite.

2.6 First Aid Measures



Adhere scrupulously to the warnings and first aid procedures indicated in the REFRIGERANT AND LUBRICANT OIL SAFETY DATA SHEET downloadable from the manufacturer's website.

3. TECHNICAL CHARACTERISTICS

3.1 Unit description

Air/water heat pump for modular installation, EMICON EVEREST290 – PAE Kp series, monobloc unit for outdoor installation, particularly suitable for residential, commercial and industrial applications where the production of hot water at high temperature is required, at the highest efficiency values on the market. Also available is the multipurpose version with 4 pipes series EMICON EVEREST290 – GPE Kp required if there is a need to produce hot water and chilled water simultaneously.

The refrigerant used is Propane, a non-toxic hydrocarbon, even at high concentrations, with almost a null ozone depletion potential, negligible global warming potential and thermodynamic properties which allow to reach high efficiency values.

All the units are totally factory assembled and tested, following specific quality procedures. Besides they are totally hydraulic, cooling and electrical connected permitting a quick installation once on site. Before the test the cooling circuits of each unit are subjected to a pressure test and then charged with Refrigerant R290 and non-freezing oil. Units are designed for outdoor installation in areas not accessible to unauthorised persons, in compliance with the European standard EN 378 and his updates.

Units CE certified in compliance with the European regulation 813/2013 (low-temperature heat pumps/average climate conditions).

3.1.1 Frame

The structure, strong and compact, is made of a base and frame in high-thickness galvanized steel elements assembled with stainless steel rivets. All galvanized steel parts placed externally are protected on the surface level with an oven powder coating system in RAL 7035 colour. The basement is designed in order to allow the unit to be forked and handled by standard lifting devices. The refrigerant circuit (except for the source side exchanger) is sealed from the rest of the unit. Internally, it also contains a refrigerant leakage sensor. In case of severe sensor alarm, the power supplied to all equipment is interrupted, except for the ATEX extraction fans, which activate in order to remove the potentially explosive atmosphere from the cabinet.

3.1.2 Compressors

The compressors, specially designed to operate with R290, are Scroll type with orbiting spirals, optimized for heat pump operating mode and high compression ratios. They are installed in tandem configuration, mounted on rubber dampers, and equipped with direct-start engines cooled by the suctioned refrigerant gas. They are also fitted with built-in thermistor protection with manual reset, which safeguards them from overloads. The crankcase oil sump, PAG type, is equipped with a heating resistor. The compressors terminal block has an IP54 protection rating. Activation and deactivation of the compressors are controlled by the on-board microprocessor, which regulates the thermo-cooling power delivered.

3.1.3 Heat exchanger

The heat exchanger is stainless steel "single-circuit" plate type, thermally insulated by a flexible closed-cell insulating mat of high thickness and UV-resistant. The evaporator is also equipped with a safety flow switch on the water flow side that does not allow the unit to operate if there is a lack of water in the heat exchanger.

3.1.4 Coils

The coils are made with micro-finned copper pipes arranged in staggered rows and mechanically expanded inside an aluminium-finned pack with hydrophilic treatment. The fin shape ensures maximum heat exchange efficiency. The innovative mini-channel technology, besides guaranteeing maximum performance in terms of heat exchange, allows the refrigerant charge to be at the minimum necessary values for the correct operation of the unit. The maximum operating pressure on the refrigerant side of the heat exchange coils corresponds to 31 bar (relative).

3.1.5 Axial Fans

Axial fans, with external rotor directly coupled to a three-phase electronically commutated motor (EC) they have the possibility of a continuous regulation of the speed by means of a 0-10V signal completely managed by the microprocessor. Aluminum blades with wings profile are suitably designed to avoid any turbulence in the air detachment zone, granting in this way the max efficiency with the minimum noise level. The fan is equipped with galvanized steel protection grid painted after the construction. Thanks to a more accurate adjustment of air flow, they allow operation of the unit with external temperature down to -20 °C.

3.1.6 Cooling circuit

The cooling circuit includes a 4-way cycle reversing valve, liquid receiver, liquid/gas separator, and electronic thermostatic expansion valves operating in parallel (to allow the unit to work constantly along the entire working range). It also includes a liquid passage and humidity indicator, filter drier, safety valve, high-pressure switches with manual and automatic reset, service valve for the addition of the refrigerant and anti-freeze probe.

3.1.7 Hydraulic circuit

The hydraulic circuit consists of a 2-pole centrifugal electric pump that allows water to circulate inside the utility-side exchanger. A check

valve that prevents the recirculation of the treated fluid in the case of a pump off and unit combined with others operating on the same water circuit. The water piping inside the unit including the Victaulic joints present are insulated in the factory with heat-insulating material of adequate thickness.

3.1.8 Electrical board

The electrical board is designed in accordance with the European standards 61439-1 EN 60204. Its structure is watertight and it contains all the components of the control system, those required for starting the unit, and the thermal protection of the electric motors, connected and factory-tested.

It houses all the power and control components: the microprocessor electronic board, with keyboard and display for the visualization of the various functions, main disconnecting switch for the door lock, and isolation transformer for the auxiliary circuit supply.

It also contains circuit breakers, fuses, and contactors for the compressor and fan motors, the terminals for the cumulative alarms and remote ON/OFF, the terminal board of the spring-type control circuits, and the possibility of connection to BMS management systems.

In case of a lack of ventilation in the compressor compartment, the unit blocks all the electrical drives.

3.1.9 Safety gas sensor

At unit start, there is the heating/initializing of the sensor (about 1' duration).

During this period the internal sensor LEDs flash, the refrigerant leakage alarm is signaled, with relevant light alarm on the electrical panel, the 24Vac auxiliary circuit is not powered and the compressor cabinet forced ventilation, made through the washing fans, is activated.

After that, no further signals arrive from the sensor, the control PLC is powered ON and the unit is ready to work.

Without refrigerant leakage alarm, the forced ventilation is cyclically made, 2' per hour, but a different timing can be set through a timer.

With refrigerant leakages, the sensor activates and the leakages signaling led immediately lights, powering the control PLC OFF, and activating the compressors cabinet washing fan. The ventilation keeps ON as long as the leakage sensor signals refrigerant presence.

The sensor has got 2 different alarm levels:

- The first one set at 20% of the LOWER FLAMMABLE LIMIT (LFL) with automatic reset; when the alarm is solved, the extraction fan stops, the PLC is again powered to return to the normal operation;
- The second one set at 30% of the LFL with manual reset; in this case, the extraction fan and the signal led will remain active and the PLC not powered till the alarm will be manually reset (disconnecting the sensor power supply or pressing the reset key inside the sensor itself).



The red lamping signal on the door of the electrical panel indicates the refrigerant leakage. Using the calibration tool it is possible to state if the sensor needs to be calibrated (see "Days left until maintenance= negative number").



THE PERIODIC MAINTENANCE OF THE SENSOR AND ITS CALIBRATION IS MANDATORY, SEE SECTION ON SCHEDULED MAINTENANCE. After 400 cumulative days of use (of power supply), the sensor goes in alarm asking for maintenance and stopping the unit.
The alarm is reset only once the maintenance is done.



Recalibration of the sensor is required after each alarm intervention.



The sensor must be replaced if, after calibration, its sensitivity falls below 55% as specified by the manufacturer.



The sensor must be calibrated every 12 months. In any case, if more restrictive, the national legislation in force must also be applied regarding the minimum calibration interval of the sensor.

3.2 Other versions

3.2.1 Standard version

PAE Kp: Reversible heat pump fully optimised for cooling operation, able to operate down to outside air temperatures of -20°C and produce hot water up to 70°C.

PAE WA Kp: Reversible heat pump fully optimised for cooling operation, able to operate down to outside air temperatures of -20°C and produce hot water up to 65°C with efficiencies such as to meet the efficiency objectives established by Ecobonus and Conto Termico.

GPE Kp: Multipurpose 4-pipes unit fully optimised for cooling operation, able to operate down to outside air temperatures of -20°C and produce hot water up to 70°C.

3.3 Options

- A+V** **Amperometer and voltmeter:** Electrical devices used to measure the electrical current absorbed and the electrical supply voltage of the unit.
- CI** **Soundproofing jacket on compressors:** made of soundproofing material, wrapped all around compressors so to further reduce the overall sound level of the unit.
- CS** **Compressors inrush counter:** Electromechanical device positioned inside the electrical board, recording the total inrush starts of compressors.
- ECP** **Anticorrosive electro coating protection of condensing coils:** Treatment of the coils composed by electro deposition process of epoxy paint particle forming an uniform and continuous film over the whole surface of exchanger, creating a flexible and smooth coating that is particularly resistant to corrosive agents. This type of treatment is indicated in case of installation in high contaminants concentration industrial environments (>100ppm), high atmospheric pollution urban areas (>125 ug/m³) or near costal areas.
- HRV2** **High pressure double safety valve**
- I1** **Victaulic insulation on pump side:** Insulation of the joints by close-cell polyurethane material, to prevent condensation, pump side.
- IH** **RS 485 Serial interface:** Electronic card to be connected to the microprocessor to allow connection of the units to supervision systems, for a remote control and monitoring of the unit. (Alternative to IH BAC).
- IWG** **SNMP or TCP/IP Protocol serial interface:** Electronic card to be connected to the microprocessor to allow the connection of the unit to external supervision system with SNMP or TCP/IP Protocol for a remote control and monitoring of the unit. (Alternative to IH or IHBAC).
- KCA** **Water collector kit without insulation:** Kit consisting of water collectors (6" diameter), ball valves, support brackets, and all the necessary for the hydraulic connection between the unit and the collectors (Supplied in kit).
- KCC** **Water collector insulation kit:** Shells made of thermal insulating material of proper thickness for the water collector insulation (KCA) (Supplied in kit).
- KG5** **Gateway framework kit up to 5 units:** Data communication framework for unit groups (up to 5). The provision for mounting the panel is on the back of the front cover of each unit. The prearrangement for the panel installation is placed on the front-cover back of each unit (Supplied in kit).
- KG10** **Gateway framework kit up to 10 units:** Data communication framework for unit groups (up to 10). The setup for the panel installation is on the back of the front-cover of each unit. The prearrangement for the panel installation is placed on the front-cover back of each unit (Supplied in kit).
- KGH5** **Gateway board kit up to 5 units complete with Hi-Web and Wi-Fi routers:** Data communication framework and serial interface for unit groups (up to 5). It allows the monitoring and supervision of the main operating parameters of the single modules and the whole system, via Hi-Web connection from the local Wi-Fi network (or from WEB network by activating a paid service). A customer device (smartphone or tablet) or tablet interface can be used as interface (optional TA).
- KGH10** **Gateway board kit up to 10 units complete with Hi-Web and Wi-Fi routers:** Data communication framework and serial interface for unit groups (up to 10). It allows the monitoring and supervision of the main working parameters of the single modules and the whole system, via Hi-Web connection from the local Wi-Fi network (or from WEB network by activating a paid service). A customer device (smartphone or tablet) or tablet interface can be used as interface (optional TA).
- KGR5** **Gateway board kit up to 5 units complete with Wi-Fi router:** Data communication framework and serial interface for unit groups (up to 5). It allows the monitoring of the operation mode of the single modules, via local Wi-Fi network (or from WEB network by activating a paid service). A customer device (smartphone or tablet) can be used as interface.
- KGR10** **Gateway board kit up to 5 units complete with Wi-Fi router:** Data communication framework and serial interface for unit groups (up to 10). It allows the monitoring of the operation mode of the single modules, via local Wi-Fi network (or from WEB network by activating a paid service). A customer device (smartphone or tablet) can be used as interface.
- KP5** **Power / executor framework kit up to 5 modules:** Electrical panel consisting of 5 circuit breakers and a main disconnecting switch for the interruption of the electrical power from the main power supply to the individual units (up to 5) (Supplied in kit).
- KP10** **Power / executor framework kit up to 10 modules:** Electrical panel consisting of 10 circuit breakers and a main disconnecting switch for the interruption of the electrical power from the main power supply to the individual units (up to 10) (Supplied in kit).
- KTT** **Victaulic cap + socket kit/weld:** Kit consisting of Victaulic caps, Victaulic sockets, and Victaulic couplings (including insulation) necessary for sealing one end of the water collector and for connecting the other end to the user circuit (Supplied in kit).

MF	Phase monitor: Electronic device that checks the correct sequence and/or the lack of one of the 3 phases, switching off the unit if necessary.
MG	Lifting hooks: Side brackets firmly fixed to the basement allow the unit to be lifted with hooks and cables.
MM	Handling brackets for forklift
MT	Pressure gauges: These enable the standing charge and the operating pressures to be monitored.
PA	Rubber-type vibration dampers: Vibration bell type dampers for insulating the unit from the support base (supplied in kit), composed of a bell base in galvanized steel and rubber compound.
PM	Spring-type vibration dampers: Spring-type vibration dampers support, for insulating the unit (supplied in kit), mainly indicated for installation in difficult and aggressive environments. Made of two steel plates containing a suitable quantity of harmonic steel springs.
PQ	Remote display: Remote interface displaying temperature values detected by probes, alarm digital inputs, outputs, remote ON/OFF of the unit. It also gives the possibility to change and program parameters and report/display alarms.
PQM	Remote display in case of multiple units
RA	Anti-freeze heater on evaporator: Electrical heater installed on the evaporator, in order to prevent freezing and provided with thermostat.
RL	Compressor overload relays: Electromechanical protection devices against compressors overload.
RR	Copper/Copper coil: Special condensing coils with copper pipes and fins.(Available for free-cooling version, only).
TA	Tablet interface: integrated inside the front cover of the unit and protected by a sheet metal door with key, it allows access to the Hi-Web and then visualization and complete control of the main operating parameters of the modular system (available in combination with optional KGH5 or KGH10).
VB	Brine Version: Unit suitable for working with evaporator outlet water temperatures lower than 0°C. A 20 mm evaporator insulation will be provided.
VH	Heating cable on internal water pipes: Electric heaters are wrapped around the water pipes of the unit. They are provided with anti-freeze function and equipped with an autonomous thermostat.

3.4 Technical data

Everest PAE 881 Kp		
Cooling ⁽¹⁾		
Nominal cooling capacity (EN14511)	kW	66,3
Total input power (EN14511)	kW	26,4
Total nominal current	A	50,8
EER (EN14511)	-	2,51 *
Refrigerant circuits	n°	1
Compressors	n°	2
Axial fans ⁽¹⁾		
Number	n°	2
Total air flow	m ³ /h	35390
Total fan power input	kW	1,8
Total fan current	A	3,3
User side plate exchanger ⁽¹⁾		
Number	n°	1
Total capacity	m ³ /h	11,3
Pressure drop	kPa	27,4 *
Diameter of water connections	DN	2" Victaulic *
Pump group P1 ⁽¹⁾		
Total electrical power input	kW	0,73
Current	A	1,4
Total electrical power input (unit side)	kW	0,2
Heating ⁽²⁾		
Heating capacity (EN14511)	kW	88,9
Total input power (EN14511)	kW	22,2
Total nominal current	A	45,9
SCOP ⁽³⁾	-	3,87 *
COP (EN14511)	-	4,00 *
Axial fans ⁽²⁾		
Total air flow	m ³ /h	32480
Total fan power input	kW	1,6
Total fan current	A	3,0
User side plate exchanger ⁽²⁾		
Total capacity	m ³ /h	15,4
Pressure drop	kPa	43,6 *
Diameter of water connections	DN	2" Victaulic *
Pump group P1 ⁽²⁾		
Total electrical power input	kW	0,8
Current	A	1,6
Total electrical power input (unit side)	kW	0,3

Everest PAE 881 Kp		
Refrigerant data R290		
Refrigerant charge	Kg	6,1
Global warming potential (GWP)	-	3
Equivalent CO ₂ charge	Kg	18.3
Weights		
Transport weight	Kg	835
Operating weight	Kg	840
Dimensions		
Length	mm	2560 *
Depth	mm	1100
Height	mm	2450 *
Sound data		
Sound pressure level ⁽⁴⁾	db(A)	87 **
Sound power level ⁽⁵⁾	db(A)	55 **
Power supply		
Voltage/Phase/Frequency	V/Ph/Hz	400/3/50 + PE

Performances are referred to the following conditions:

(1) Fluid: water - in/out temperature: 12/7°C - air 35°C.

(2) Fluid: water - in/out temperature: 30/35°C - air 7°C - UR.87%

(3) Calculated according to EU.813/2013

(4) Sound power level in accordance with ISO 3744.

(5) Sound pressure level at 10 mt from the unit in free field conditions in accordance with ISO 3744.

** In case of modular system see paragraph "3.7 Sound data".



Technical data are not binding and may change without notice, therefore ALWAYS refer to the data sheet received with the offer.



Technical data relating to the unit. In the case of a modular system with n units, multiply the data (except those marked with *) by n to obtain the total values.

Everest PAE 881 WA Kp		
Cooling ⁽¹⁾		
Nominal cooling capacity (EN14511)	kW	105
Total input power (EN14511)	kW	29,6
Total nominal current	A	55,0
EER (EN14511)	-	3,55 *
SEER ⁽²⁾	-	4,58
Refrigerant circuits	n°	1
Compressors	n°	2
Axial fans ⁽¹⁾		
Number	n°	2
Total air flow	m ³ /h	38770
Total fan power input	kW	2,3
Total fan current	A	4,1
User side plate exchanger ⁽¹⁾		
Number	n°	1
Total capacity	m ³ /h	18,0
Pressure drop	kPa	55,5 *
Diameter of water connections	DN	2" Victaulic *
Pump group P1 ⁽¹⁾		
Total electrical power input	kW	0,9
Current	A	1,6
Total electrical power input (unit side)	kW	0,5
Heating ⁽³⁾		
Heating capacity (EN14511)	kW	88,2
Total input power (EN14511)	kW	22,5
Total nominal current	A	46,3
SCOP ⁽⁴⁾	-	3,77 *
COP (EN14511)	-	3,92 *
Axial fans ⁽³⁾		
Total air flow	m ³ /h	32470
Total fan power input	kW	1,54
Total fan current	A	3,01
User side plate exchanger ⁽³⁾		
Total capacity	m ³ /h	15,3
Pressure drop	kPa	43,5 *
Diameter of water connections	DN	2" Victaulic *
Pump group P1 ⁽³⁾		
Total electrical power input	kW	0,8
Current	A	1,6
Total electrical power input (unit side)	kW	0,3

Everest PAE 881 WA Kp		
Refrigerant data R290		
Refrigerant charge	Kg	6,1
Global warming potential (GWP)	-	3
Equivalent CO ₂ charge	Kg	18.3
Weights		
Transport weight	Kg	835
Operating weight	Kg	840
Dimensions		
Length	mm	2560 *
Depth	mm	1100
Height	mm	2450 *
Sound data		
Sound pressure level ⁽⁵⁾	db(A)	87 **
Sound power level ⁽⁶⁾	db(A)	55 **
Power supply		
Voltage/Phase/Frequency	V/Ph/Hz	400/3/50 + PE

Performances are referred to the following conditions:

- (1) External air temperature: 35°C - Water Tin/Tout: 23/18°C
- (2) Calculated according to EU.2016/2281 - Cooling floor application (23/18°C)
- (3) Air 7°C / 87% HR - Water Tin/Tout: 30/35°C
- (4) Calculated according to EU.813/2013
- (5) Sound power level in accordance with ISO 3744.
- (6) Sound pressure level at 10 mt from the unit in free field conditions in accordance with ISO 3744

** In case of modular system see paragraph "3.7 Sound data".



Technical data are not binding and may change without notice, therefore ALWAYS refer to the data sheet received with the offer.



Technical data relating to the unit. In the case of a modular system with n units, multiply the data (except those marked with *) by n to obtain the total values.

Everest GPE 881 Kp		
Cooling ⁽¹⁾		
Nominal cooling capacity (EN14511)	kW	72,1
Total input power (EN14511)	kW	26,6
Total nominal current	A	51,1
EER (EN14511)	-	2,71 *
Refrigerant circuits	n°	1
Compressors	n°	2
Axial fans ⁽¹⁾		
Number	n°	2
Total air flow	m ³ /h	35070
Total fan power input	kW	1,7
Total fan current	A	3,2
Cold user side plate exchanger ⁽¹⁾		
Number	n°	1
Total capacity	m ³ /h	12,3
Pressure drop	kPa	32,4 *
Diameter of water connections	DN	2" Victaulic *
Pump group P1F ⁽¹⁾		
Total electrical power input	kW	0,8
Current	A	1,5
Total electrical power input (unit side)	kW	0,2
Heating ⁽²⁾		
Heating capacity (EN14511)	kW	86,7
Total input power (EN14511)	kW	22,2
Total nominal current	A	44,6
COP (EN14511)	-	3,91 *
Axial fans ⁽²⁾		
Total air flow	m ³ /h	34120
Total fan power input	kW	1,8
Total fan current	A	3,4
Hot user side plate exchanger ⁽²⁾		
Total capacity	m ³ /h	15
Pressure drop	kPa	41,7 *
Diameter of water connections	DN	2" Victaulic *
Pump group P1C ⁽²⁾		
Total electrical power input	kW	0,8
Current	A	1,6
Total electrical power input (unit side)	kW	0,3
Cooling while heating ⁽³⁾		
Cooling capacity (EN14511)	kW	79,5
Heating capacity (EN14511)	kW	101
Total input power	kW	21,5
Total nominal current	A	45,42
TER (EN14511)	-	8,40 *
Hot user side plate exchanger ⁽³⁾		
Inlet temperature	°C	30
Outlet temperature	°C	35,8
Total capacity	m ³ /h	15
Pressure drop	kPa	41,7 *

Everest GPE 881 Kp		
Pump group P1C ⁽³⁾		
Total electrical power input	kW	0,8
Current	A	1,6
Total electrical power input (unit side)	kW	0,3
Cold user side plate exchanger ⁽³⁾		
Inlet temperature	°C	12
Outlet temperature	°C	6,4
Total capacity	m ³ /h	12,3
Pressure drop	kPa	32,5 *
Pump group P1F ⁽³⁾		
Total electrical power input	kW	0,8
Current	A	1,5
Total electrical power input (unit side)	kW	0,2
Refrigerant data R290		
Refrigerant charge	Kg	6,1
Global warming potential (GWP)	-	3
Equivalent CO ₂ charge	Kg	18,3
Weights		
Transport weight	Kg	920
Operating weight	Kg	935
Dimensions		
Length	mm	2560 *
Depth	mm	1100
Height	mm	2450 *
Sound data		
Sound pressure level ⁽⁴⁾	db(A)	87 **
Sound power level ⁽⁵⁾	db(A)	55 **
Power supply		
Voltage/Phase/Frequency	V/Ph/Hz	400/3/50 + PE

Performances are referred to the following conditions:

(1) Fluid: water - in/out temperature: 12/7°C - air 35°C.

(2) Fluid: water - in/out temperature: 30/35°C - air 7°C - UR.87%

(3) Cold user side: in temperature: 12°C - Nominal flow rate cooling- Hot user side: in temperature: 30°C - Nominal flow rate heating.

(4) Sound power level in accordance with ISO 3744.

(5) Sound pressure level at 10 mt from the unit in free field conditions in accordance with ISO 3744.

** In case of modular system see paragraph "3.7 Sound data".



Technical data are not binding and may change without notice, therefore ALWAYS refer to the data sheet received with the offer.



Technical data relating to the unit. In the case of a modular system with n units, multiply the data (except those marked with *) by n to obtain the total values.

3.5 Operational limits

3.5.1 PAE Kp

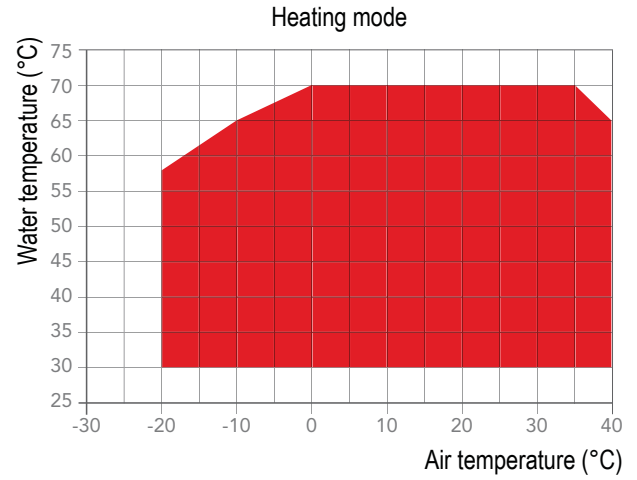
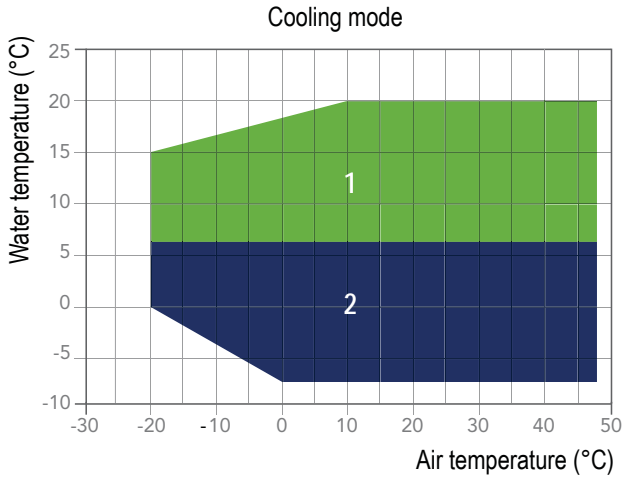

- 1 Cooling mode
- 2 Cooling with glycol

3.5.2 PAE WA Kp

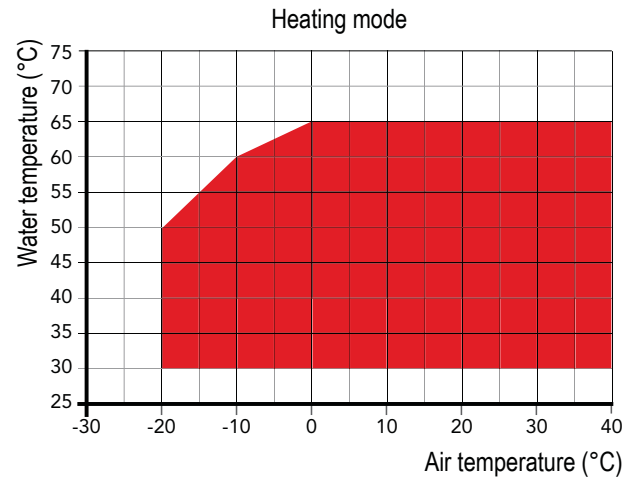
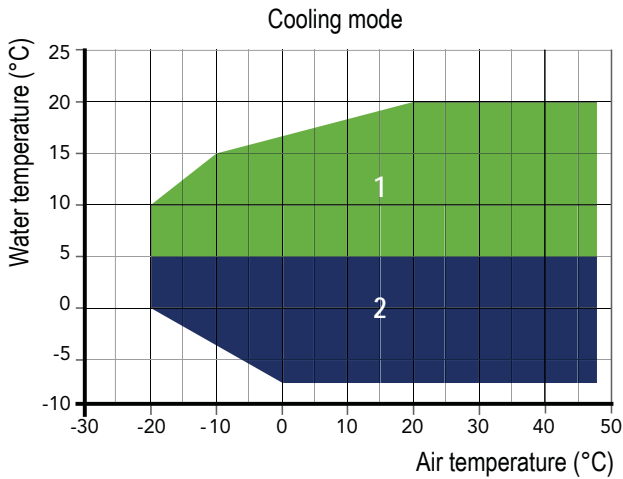

- 1 Cooling mode
- 2 Cooling with glycol

3.5.3 GPE Kp

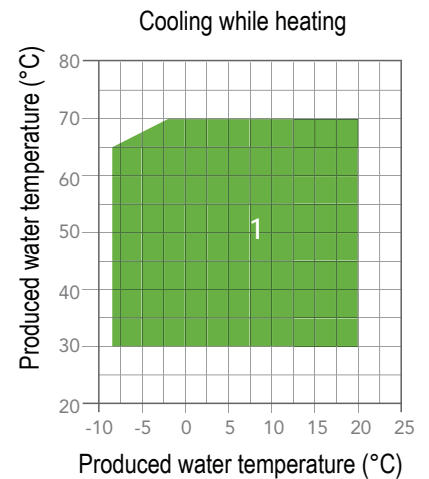
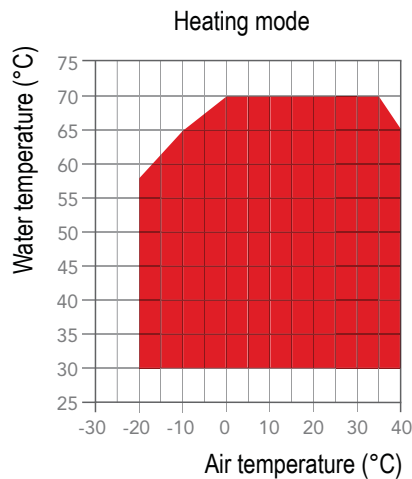
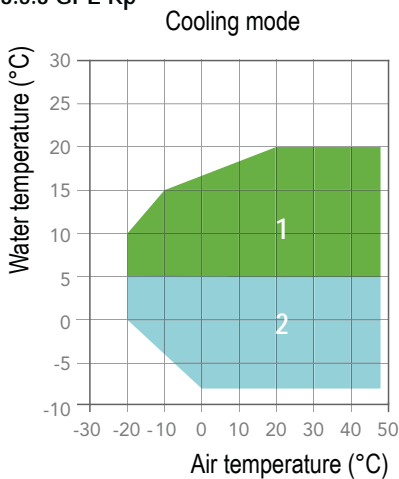

- 1 Cooling mode
- 2 Cooling with glycol

3.5.4 User heat exchanger water flow rate

The nominal water flow rate provided, relates to a ΔT of 5°C.

The minimum water flow rate allowed is that which results in a ΔT of 7°C. Insufficient flow will result in evaporating temperatures that are too low leading to the operation of safety devices that will prevent unit operation.



Units are designed and manufactured to European safety and technical standards. The units have been designed exclusively for cooling and DHW production. The units must be used for this specific purpose only. The Company will not be liable for claims for damage caused to persons, animals or material goods or property caused by improper installation, adjustment and maintenance or improper use. Any use not specified in this manual is prohibited.



In case of operations outside of these values, please contact the company.



If the unit is installed in particularly windy areas, it will be necessary to provide some windbreaker barriers to avoid any malfunction. We suggest to install the barriers only if the wind exceeds 2,5m/s.



The units, in their standard configuration, are not suitable for installation in saline environments.

3.6 Correction tables

3.6.1 Operation with glycol

Glycol percentage	Freezing point (°C)	CCF	IPCF	WFCF	PDCF
10	-3.2	0.985	1	1.02	1.08
20	-7.8	0.98	0.99	1.05	1.12
30	-14.1	0.97	0.98	1.09	1.22
40	-22.3	0.965	0.97	1.14	1.25
50	-33.8	0.955	0.965	1.2	1.33

CCF: Capacity correction factor

IPCF: Input power correction factor

WFCF: Water flow correction factor

PDCF: Pressure drops correction factor

The water flow rate and pressure drop correction factors are to be applied directly to the values given for operation without glycol. The water flow rate correction factor is calculated in order to maintain the same temperature difference as that which would be obtained without glycol. The pressure drop correction factor takes into account the different flow rate obtained from the application of the flow rate correction factor.

3.6.2 Correction tables different Δt

Water temperature diff.(°C)	3	5	8
CCCP	0.99	1	1.02
IPCF	0.99	1	1.01

CCCP = Cooling capacity correction factor

IPCF = Input power correction factor

3.6.3 Correction tables different Fouling factors

Fouling factor	0.00005	0.0001	0.0002
CCCP	1	0.98	0.94
IPCF	1	0.98	0.95

CCCP = Cooling capacity correction factor

IPCF = Input power correction factor

3.7 Sound data



The sound level reported is calculated at the cooling-only operating condition.

EVEREST 290											
Mod.	Octave bands (Hz)								Lw dB(A)	Lp1 dB(A)	Lp10 dB(A)
	63 dB(A)	125 dB(A)	250 dB(A)	500 dB(A)	1K dB(A)	2K dB(A)	4K dB(A)	8K dB(A)			
PAE 881 Kp	43	51	69	76	79	84	76	63	86,5	68,3	54,6
PAE 881 WA Kp	43	51	69	76	79	84	76	63	86,5	68,3	54,6
GPE 881 Kp	43	51	69	76	79	84	76	63	86,5	68,3	54,6



In the case of a modular system consisting of 1 to n modules, the total value of the sound level can be estimated by the following formula:

$$Leq_{tot} = 10 \times \log_{10} [n \times (10^{Lw/10})]$$

4. INSTALLATION

4.1 General safety guidelines and use of symbols



Before undertaking any task the operator must be fully trained in the operation of the machines to be used and their controls. They must also have read and be fully conversant with all operating instructions.



All maintenance must be performed by TRAINED personnel and be in accordance with all national and local regulations.



The installation and maintenance of the unit must comply with the local regulations in force at the time of the installation.



Avoid contact and do not insert any objects into moving parts.

4.2 Health and safety Considerations



The workplace must be kept clean, tidy and free from objects that may prevent free movement. Appropriate lighting of the work place shall be provided to allow the operator to perform the required operations safely. Poor or too strong lighting can cause risks.



Ensure that work places are always adequately ventilated and that respirators are working, in good condition and comply fully with the requirements of the current regulations.

4.3 Personal protective equipment



When operating and maintaining the unit, use the following personal protective equipment listed below as required by law.



Protective footwear.



Eye protection.



Protective gloves.



Respiratory protection.



Hearing protection.

4.4 Inspection

When installing or servicing the unit, it is necessary to strictly follow the rules reported on this manual, to conform to all the specifications of the labels on the unit, and to take any possible precautions of the case. Not observing the rules reported on this manual can create dangerous situations. After receiving the unit, immediately check its integrity. The unit left the factory in perfect conditions; any eventual damage must be questioned to the carrier and recorded on the Delivery Note before it is signed. The company must be informed, within 8 days, of the extent of the damage. The Customer should prepare a written statement of any severe damage.

Before accepting the unit check:

- The unit did not suffer any damage during transport;
- The delivered goods are conforming to what shown in the delivery note.

In Case of Damage

- List the damage on the delivery note
- Inform the Company of the extent of the damage within 8 days of receipt of the goods. After this time any claim will not be considered.
- A full written report is required for cases of severe damage.

4.5 Transport and handling

In compliance with the EN 378-1, the unit can be identified as an indirect closed system, The refrigerant charge and type are indicated on the unit identification tag.

The unit handling must be done by skilled personnel only, with suitable equipment to the unit weight and dimensions. During the handling operations, keep the unit in vertical position (i.e. with the basement parallel to the ground)



The transport company is always responsible for any possible damage during the transport of the goods. Before installing the unit and preparing it for the commissioning, accurately sight inspect the unit to verify the packaging integrity or that the unit has no visible damage, and oil or refrigerant leakage. Also verify that the unit complies what required in phase of order.



Any possible damage or claim must be communicated to the Manufacturer or to the carrier by means of registered mail within 8 days from goods receipt.



If one or more components are damaged, do not start the unit, and immediately inform the manufacturer, in order to agree any intervention on the unit.



It is suggested to unpack the unit at effective unit installation place. The internal handling must be done with care, avoiding using the equipment components as holds. Avoid any damage during the unit handling.



The hydraulic circuit must be fully empty before anyhow move the unit.



The units lifting must be vertical, preferably done by means of a forklift. Use a distribution beam if straps or ropes are used for the harness, carefully checking that no pressure is done on the higher edges of the unit or of the packaging.

PAY ATTENTION:

The refrigerant contained in the unit is flammable.

The unit can be installed outside only, away from any kind of possible ignition source and from direct sunlight.

Max external air temperature: +40°C (in chilled water production mode) (see operating limits).



4.6 Storage

If it is necessary to store the unit, leave it packed in a closed place. If for any reason the machine has already been unpacked, follow these instructions to prevent damage, corrosion and/or deterioration:

- Make sure that all openings are properly closed or sealed;
- Never use steam or other cleaning agents to clean the unit that could damage it;
- Remove any keys needed to access the control panel and entrust them to the site manager.



The unit can be stored at temperatures between -20°C and 65°C.



Exceeding the maximum storage temperature entails the risk of leakage of the refrigerant through the safety valve and the consequent formation of a potentially explosive mixture.



During the period of non-use, in order to prevent corrosive phenomena, deposits or breakages due to the formation of ice, it is of fundamental importance that the heat exchangers, on the utility side, are totally empty or completely full of adequately glycolated water.

4.7 Unpacking



Packaging could be dangerous for the operators.

It is advisable to leave packaged units during handling and remove it before the installation.

The packaging must be removed carefully to prevent any possible damage to the machine.

The materials constituting the packaging may be different in nature (wood, cardboard, nylon, etc.).



The packaging materials should be separated and sent for disposal or possible recycling to specialist waste companies.

4.8 Lifting and handling

The unit can be moved in the following ways:

1. Using a forklift truck or forklift: In this case, the unit must be pressed into the slots on the long sides of the base. The gripping points are protected by a yellow mask made of iron, the aim of which is to protect the painting of the base from the sliding of the forks. At the end of the handling operations, the masks can be removed.

2. Using cranes or hoists: In this case it is necessary to create an integral anchor by means of rope hooks or similar to the appropriate lifting brackets, available on request and supplied as a kit (optional MG).



In the absence of the above lifting brackets, the Company is relieved of any damage during handling and/or lifting operations by cranes, hoists or other lifting systems that involve the use of ropes and/or belts or similar.



Use a distributor beam if harness straps or ropes are used, making sure there is no pressure on the top edges of the unit or on the packaging.



When handling or lifting, the following must be performed:

- Make sure that the vehicle being used has sufficient load capacity;
- Make sure that the forks cross the entire width of the unit;
- Provide any protection to avoid damaging the unit;
- Avoid abrupt or violent manoeuvres;
- Make sure all the panels are closed;
- Use a distributor beam in case of lifting by means of belts to avoid pressures on the carpentry of the unit;
- Use means and/or devices in accordance with the law;
- Keep the unit horizontal; the maximum inclination must not exceed 5°;
- Comply with the current regulations and standards.

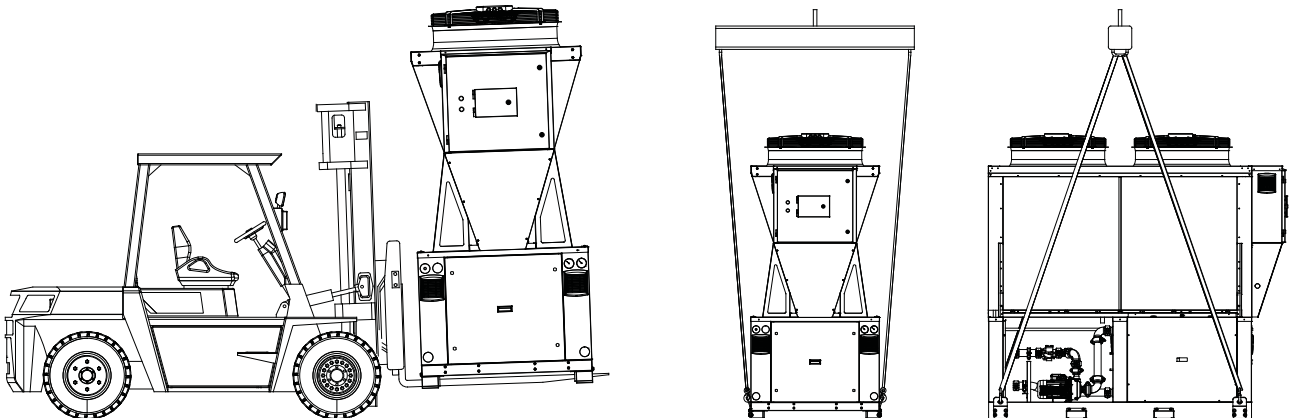

The Source heat exchangers fins are sharp. Use protection gloves.

4.9 Location and minimum technical clearances

All units are designed for external installation. Any overhang above the unit and location near trees, if they partially cover the unit, must be avoided in order to prevent air by-pass. Otherwise this could result in deterioration of the unit's performance or even the interruption of normal operation. In this regard, it is necessary to ensure the minimum service spaces indicated below.

Ideally create a support slab that is the correct size for the unit. The units transmit a low level of vibrations to the ground; however, it is advisable to interpose between the base frame and the support surface a number of anti-vibration supports.

For safety reasons, inside this area, no further devices, systems or ignition sources must be installed. Inside this area, the surfaces must not reach a temperature higher than 100 K from the auto-ignition temperature of the used refrigerant.

If the unit is installed in a zone with Class A (Generic) or Class B (with Supervision) presences, in compliance with the EN 378-1, par. 4.1, only the authorized person must be allowed near the unit, inside the spaces to be left free.

The unit must be positioned as much far as possible, and anyway at 4 m minimum, from drainage or electrical systems, wells and drains, in order to avoid the spread of potentially explosive atmospheres, in case of refrigerant leakages.

In any case, all the systems nearby the unit, must be filled with sand or equipped with siphon. The underground pipelines must be positioned at 0.80 m under the ground level at least.

The systems must be inspected every 6 months at least, in order to verify that the taken precaution to avoid the propagation of explosive atmospheres are efficient.



The group must be installed so that any possible refrigerant leakage cannot penetrate inside any building or closed ambient.



The unit has to be installed such that maintenance and repair is possible. The warranty does not cover costs for the provision of lifting apparatus, platforms or other lifting systems required to perform repairs during warranty period.



The installation site should be chosen in accordance with EN 378-1 and 378-3 standards. When choosing the installation site, all risks caused by accidental refrigerant leakage should be taken into consideration.



The unit must be anchored to the support base to avoid damage in the event of an earthquake or strong wind. In any case, if the area is frequently subject to strong wind, appropriate barriers must be provided to ensure the correct operation of the unit.



If snow accumulation is possible at the installation site, it is advisable to lift the unit at least 400 mm above the ground.



The installation site of the units must only be accessible to authorised personnel. Access to the public must in any case be prohibited.

4.9.1 ATEX minimum technical spaces

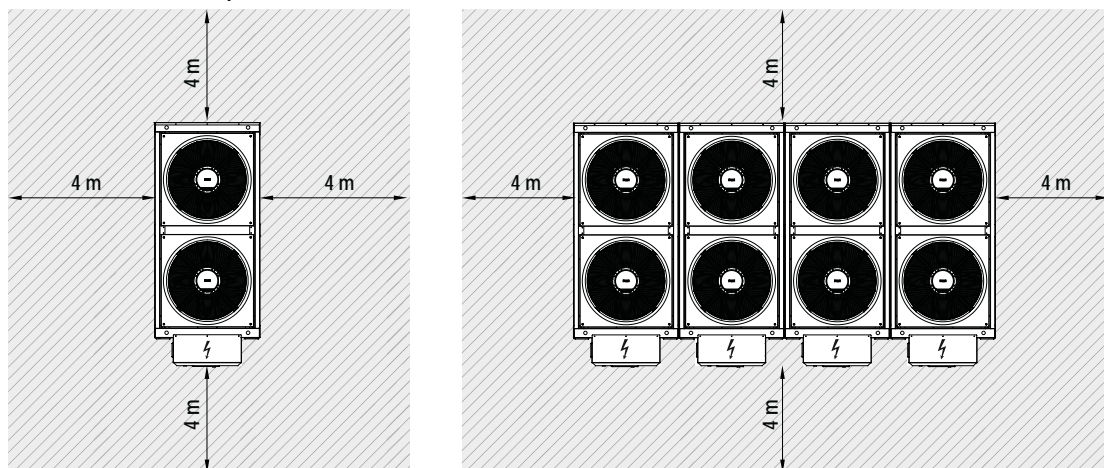

4.9.2 Single unit minimum technical spaces

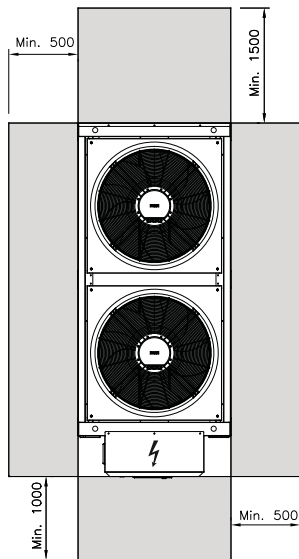

4.9.3 Modular system minimum technical spaces

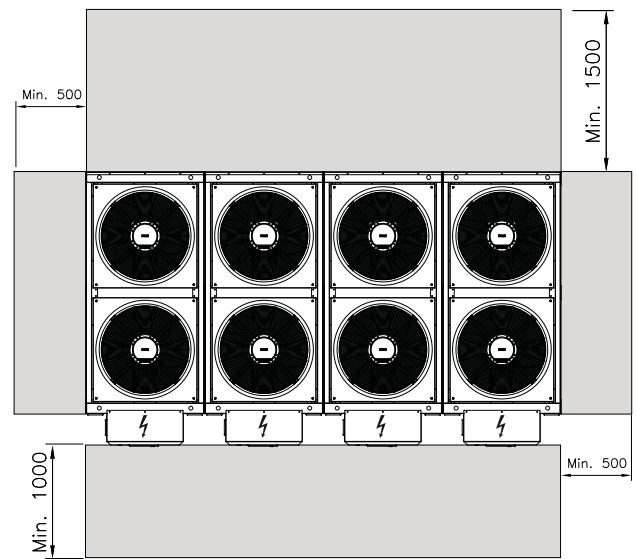

4.9.3 Connecting and positioning multiple units

The units of the EVEREST290 range are modular machines designed to work in parallel with each other, served by a single hydraulic circuit, up to a maximum of 10 units. If the installation involves such a configuration (modular system) the modules must be placed next to each other on a base that guarantees maximum stability and coplanarity to the entire system. Each module must be firmly anchored to the ground and the adjacent modules must be mechanically joined together using the fastening brackets supplied. The arrangement for the fixing of these brackets by means of screws is provided in the high edges on the front and rear side of each unit.

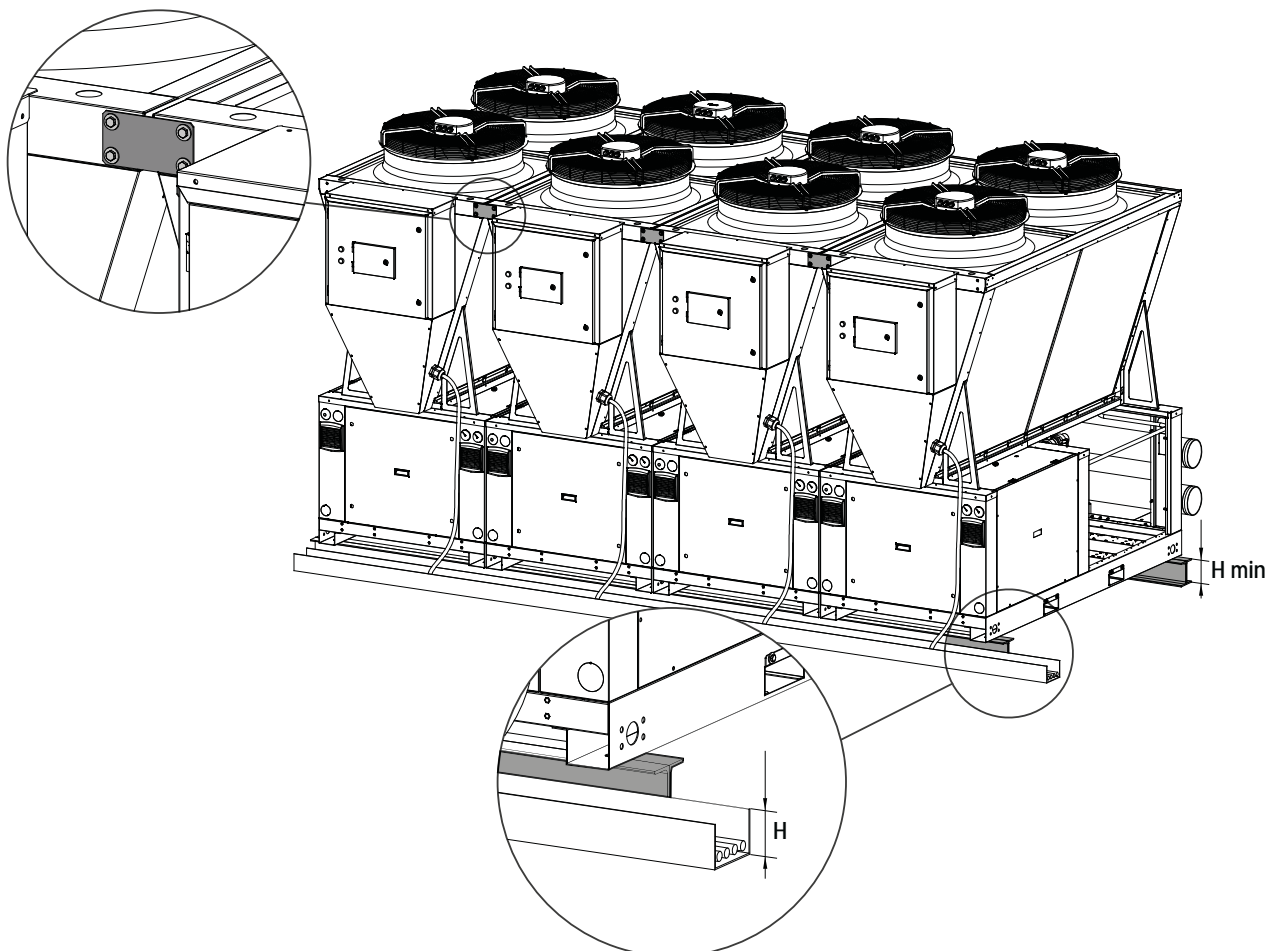



It is advisable to place the unit on a support base of height H_{min} , such that $H_{min} > H$ where H represents the height of the electrical dorsal system created frontally on the ground with respect to the modular system. This means being able to remove the unit from the system without having to remove all the power cables of the other units.

Subsequently it is possible to continue with the creation of the water-side manifolds (KCA kit available on request) following the indications described in the instruction sheet.

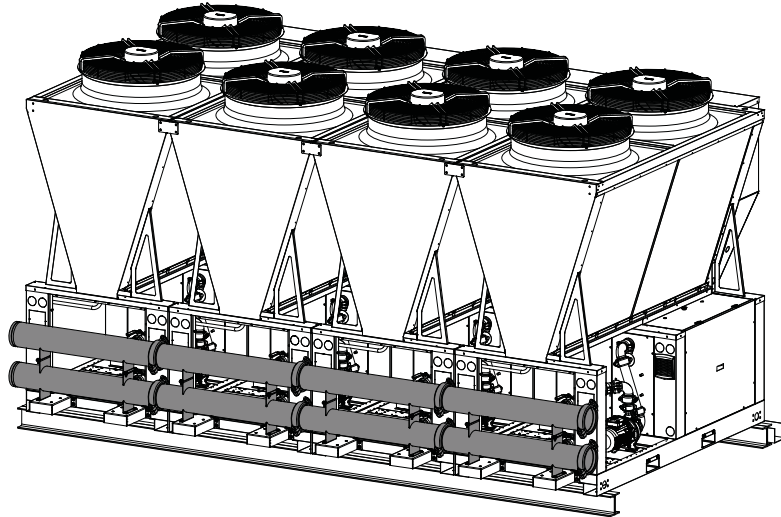

If the installation of the units takes place above a building, it is advisable to provide a system capable of attenuating vibrations and consequently the transmission of noise to the underlying premises (for example by means of shock absorbers or other anti-vibration systems)

4.10 Hydraulic connections

The water pipe-work must be installed in accordance with national and local regulation and can be made from copper, steel, galvanized steel or PVC. The Pipework must be designed to cater for the nominal water flow and the hydraulic pressure drops of the system, a maximum pressure drop of 300 Pa/m run being typical. All pipes must be insulated with closed-cell material of adequate thickness. The hydraulic piping of the unit or modular system should include:

- Pockets for temperature sensor to measure the temperature in the system.
- Flexible joints, to isolate the unit from the rest of the system.
- Temperature and pressure gauges for maintenance and servicing operations.
- Shut-off manual valves to isolate the unit from the hydraulic circuit.
- Metallic filters to be mounted on the inlet pipe with a mesh not larger than 1 mm.
- Vent valves, expansion tank with water filling, discharge valve.



The hydraulic connection diameters are specified in the "Technical Data" table.



System return water must be fitted to the connection labelled: "USER WATER IN" as incorrect connection can damage the heat exchanger by freezing.



It is compulsory to install on the USER WATER IN connection, a water strainer with a mesh not larger than 1 mm. Fitting this filter is **COMPULSORY** and the warranty will be invalidated if it is removed. The filter must be kept clean and checked periodically.

The connection of the unit to the hydraulic circuit must be carried out by an experienced and qualified technician in accordance with the local regulations in force.



The connection of the unit to the system must be carried out in such a way that the fluid to be cooled circulates in the exchangers in the correct direction. To this purpose, the pipes must be connected in compliance with the instructions given in the connection on the unit.

To connect the pipes to the evaporator, take care of the following advises:

- Connect the pipes as shown in picture

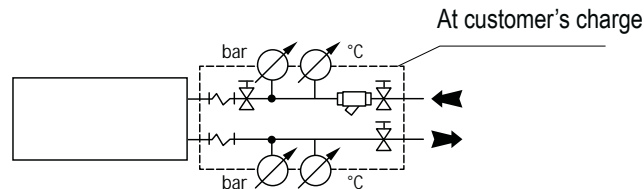

- To avoid any vibration transmission and permit the thermal expansions, anti-vibration fittings must be installed on the pipes ;
- To avoid the inlet of foreign bodies and particles, you need to install, on unit inlet, a cleanable mechanic filter, with mesh dimension not larger than 1mm and with suitable nominal diameter, to reduce pressure drops;
- The installation of shut-off valve up and down stream of the filter is recommended, in order to make the cleaning operation simpler and quicker;
- The installation of thermometers and gauges near the inlet and outlet connection of the device, make the check of the unit operation easier;
- The chilled water system must be coated with close-cells anti-condensation material, with thermal insulation characteristics, vapor impermeability and with suitable thickness for the worst foreseeable conditions;
- Use the pre-arranged connection shown in the attached dimensional drawing to connect the unit to the hydraulic system;
- Once the circuit is done and the unit installed, seal test of the whole system must be done, in order to find out any possible leakage and repair it, before the circuit filling and commissioning.



After the seal test, if the start-up of the system is planned after a long period of stop or if the ambient temperature can go down till values near to 0°C or lower, you need to drain the water from the circuit or enter a suitable percentage of glycol.



If the unit is not to be used during the winter period, the water contained in the pipes may freeze and cause serious damage. In this event, fully drain the water from the pipes, checking that all parts of the circuit are empty including any internal or external traps and siphons.



In case of breaking of the user side exchanger, the refrigerant can enter the water circuit. Position then the vent valves of the system in airy zone and far from manholes where the refrigerant could be concentrated, creating potentially explosive atmospheres. If not possible, the closed ambient where these vent valves are present, must be arranged with the precautions stated in the EN-378.



The intervention of automatic degassers can generate a potentially explosive zone of spherical shape and radius ≥ 2 m. Therefore place these devices away from possible sources of ignition.



All units are factory supplied with a flow switch; the flow switch **MUST BE FITTED** in the pipework connection labelled "USER WATER OUT". If the flow switch is altered, removed, or the water filter omitted on the unit, the warranty will be invalidated.



When starting the unit for the first time, it is necessary to load it with clean water with chemical-physical characteristics such as to prevent corrosive phenomena or deposits of any kind. For this purpose, it is advisable to check annually the stability of the pH.

4.11 Hydraulic circuit

The units of the EVEREST290 range include a centrifugal pump on each of the plate heat exchangers present, with the aim of feeding the heat exchangers themselves with an adequate flow value of the heat transfer fluid in any operating condition. This design choice guarantees high stability and reliability of operation to the modular system. The heat exchangers of the units in operation in fact always work at constant flow values. In this way, the negative effects of the adjustment made by changing the supply flow of the heat exchangers themselves (suspensions, liquid returns to the compressors, problems related to the control logic) are cancelled. The units switched off (partialised system operating speed) are completely by-passed by check valves and the relative pumps will be switched off.

The on-board pump has been sized to overcome the pressure drops inside the unit and allow the fluid to travel through the common manifold until reaching an inertial tank or an additional manifold, located in the immediate vicinity of the refrigeration unit. It is therefore essential to provide for booster systems of the carrier fluid arriving from the units or from the modular system towards the individual users through pumping units operating on the secondary circuit.

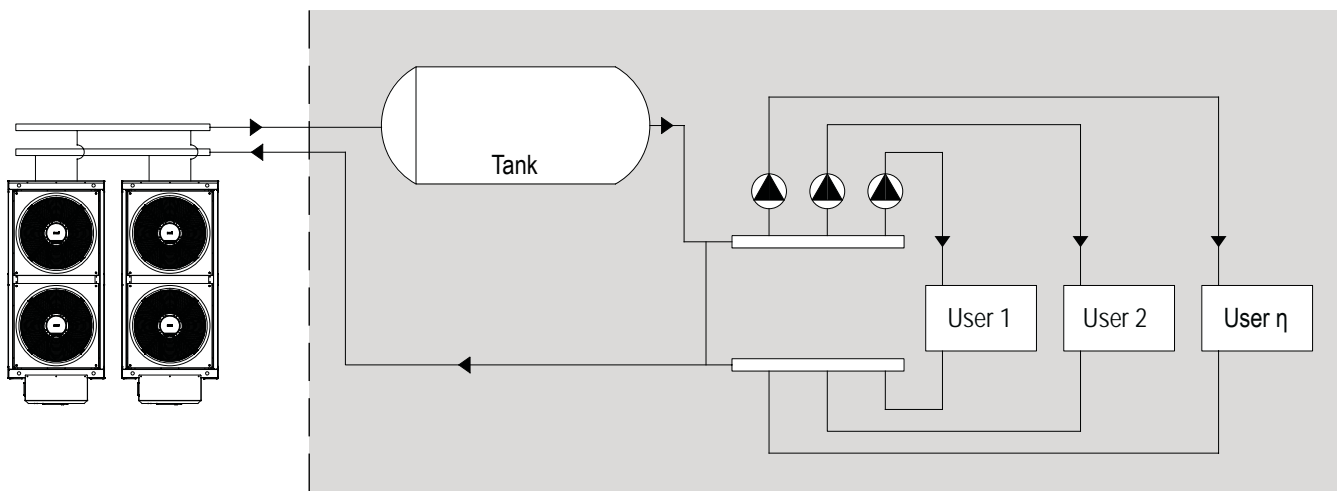

EVEREST290 modular system

Installation site



It is absolutely forbidden to provide control/mixing systems that limit or interfere in any way with the input flow to the machines; the Company is not responsible in any way for problems related to control or operation and/or damage to the units.



The use of plant solutions other than those proposed relieves the Company of any responsibility.

4.12 Chemical characteristics of the water

In the following table there are, just as an indication, the main values of chemical and physical properties of the water to be respected to avoid corrosion or any sediment. To this purpose it is advisable yearly check PH stability.

<p>Table key</p> <p>+ Good resistance under normal conditions</p> <p>0 Corrosion problems may occur especially when more factors are valued 0</p> <p>- Use is not recommended</p>	<p>Important Note: The following parameters can also influence the corrosion resistance</p> <p><u>Temperature:</u> The data in the table are based water temperature of 20°C unless otherwise is stated.</p> <p><u>Presence of oxidants</u> in the environment: guidelines regarding the oxygen content are shown in Table 3.</p> <p><u>Product form</u>, heat treatment and presence of intermetallic phases: The data in the table is based on untreated raw material.</p>
--	---

WATER CONTENT	CONCENTRATION (mg/l or ppm)	TIME LIMITS Analyze before	Plate Material		Brazing Material		
			AISI 304	AISI 316	COPPER	NICKEL	STAINLESS STEEL
Alkalinity (HCO ₃ ⁻)	< 70	Within 24 h	+	+	0	+	+
	70-300		+	+	+	+	+
	> 300		+	+	0/+	+	+
Sulphate ^[1] (SO ₄ ²⁻)	< 70	No limit	+	+	+	+	+
	70-300		+	+	0/-	+	+
	> 300		+	+	-	+	+
HCO ₃ ⁻ / SO ₄ ²⁻	> 1.0	No limit	+	+	+	+	+
	< 1.0		+	+	0/-	+	+
Electrical conductivity ^[2] (Refer to Table 3 for oxygen content guidelines)	< 10 µS/cm	No limit	+	+	0	+	+
	10-500 µS/cm		+	+	+	+	+
	> 500 µS/cm		+	+	0	+	+
pH ^[3]	< 6.0	Within 24 h	0	0	0	+	0
	6.0-7.5		+	+	0	+	+
	7.5-9.0		+	+	+	+	+
	9.0-10		+	+	0/+ ^[4]	+	+
	>10.0		+	+	0	+	+
Ammonium (NH ₄ ⁺)	< 2	Within 24 h	+	+	+	+	+
	2-20		+	+	0	+	+
	>20		+	+	-	+	+
Chlorides (Cl ⁻) (Refer to Table 2 for temperature- dependent values)	<100	No limit	+	+	+	+	+
	100-200		0	+	+	+	+
	200-300		-	+	+	+	+
	300-700		-	0/+	0/+	+	-
	>700		-	-	0	+	-
Free chlorine (Cl ₂)	< 1	Within 5 h	+	+	+	+	+
	1-5		-	-	0	+	-
	> 5		-	-	0/-	+	-
Hydrogen sulfide (H ₂ S)	< 0.05	No limit	+	+	+	+	+
	>0.05		+	+	0/-	+	+
Free (aggressive) carbon dioxide (CO ₂)	< 5	No limit	+	+	+	+	+
	5-20		+	+	0	+	+
	> 20		+	+	-	+	+
Total hardness ^[5] (Refer to "Scaling Document" for scaling aspect of hardness effect)	4.0 - 11 °dH	No limit	+	+	+	+	+
	70 - 200 mg/l CaCO ₃		+	+	+	+	+
Nitrate ^[1] (NO ₃ ⁻)	< 100	No limit	+	+	+	+	+
	> 100		+	+	0	+	+
Iron ^[6] (Fe)	< 0.2	No limit	+	+	+	+	+
	> 0.2		+	+	0	+	+
Aluminium (Al)	< 0.2	No limit	+	+	+	+	+
	> 0.2		+	+	0	+	+
Manganese ^[6] (Mn)	< 0.1	No limit	+	+	+	+	+
	> 0.1		+	+	0	+	+

CHLORIDE CONTENT	MAXIMUM TEMPERATURE					
	20°C	30°C	60°C	80°C	120°C	130°C
= 10 ppm	SS 304	SS 304	SS 304	SS 304	SS 304	SS 316
= 25 ppm	SS 304	SS 304	SS 304	SS 304	SS 316	SS 316
= 50 ppm	SS 304	SS 304	SS 304	SS 316	SS 316	Ti
= 80 ppm	SS 316	SS 316	SS 316	SS 316	SS 316	Ti
= 200 ppm	SS 316	SS 316	SS 316	SS 316	Ti	Ti
= 300 ppm	SS 316	SS 316	SS 316	Ti	Ti	Ti
=700 ppm	SS 316	SS 316	Ti	Ti	-	-
=1000 ppm	SS 316	Ti	Ti	Ti	-	-
> 1000 ppm	Ti	Ti	Ti	Ti	-	-

In order to prevent corrosive phenomena or deposits of any nature it is recommended to:

- Empty the evaporator before any maintenance work is carried out;
- Do not clean the evaporator with unsuitable mechanical systems, such as drill bits or high-pressure jets;
- Do not clean with too aggressive cleaning agents. Before using a chemical detergent, check the compatibility with the construction materials of the exchanger.



In case of long stops, leave the heat exchanger completely filled with adequate glycol water or completely empty.

4.13 User circuit minimum water content



Heat pump units need a minimum water content inside the user circuit in order to guarantee the correct functioning of the unit. A correct water content reduces the n° of starts-and-stops of the compressors and this extends the operating life of the unit and allows a reduced reduction of the hot water temperature during the defrosting cycle. For these reason it's necessary to guarantee to the unit the following minimum water contents in the user circuit:
 Recommended water content : 15l/kW
 Recommended minimum water content : 20 lt. x Thermal power (kW) / Number of compressors.

PAE 881 Kp	
Minimum (l)	900
PAE 881 WA Kp	
Minimum (l)	900
GPE 881 Kp	
Minimum (l)	900

4.14 Filling the hydraulic circuit

- Before filling, check that the installation drain valve is closed.
- Open all pipework, heat pump and terminal unit air vents.
- Open the shut off valves.
- Begin filling, slowly opening the water valve in the filling group outside the unit.
- When water begins to leak out of the terminal air vent valves, close them and continue filling until the pressure gauge indicates a pressure of 1.5 bars.

The installation should be filled to a pressure of between 1 and 2 bars. It is recommended that this operation be repeated after the unit has been operating for a number of hours (due to the presence of air bubbles in the system). The pressure of the installation should be checked regularly and if it drops below 1 bar, the water content should be topped-up. If frequent top-ups are required, check all connections for leaks.

4.15 Emptying the installation

- Before emptying, place the mains switch in the “Off” position.
- Make sure the filling group valve is closed.
- Open the drainage valve outside the unit and all the installation and terminal air vent valves.



If the fluid in the circuit contains anti-freeze, it MUST not be allowed to run away to drain. It must be collected for possible re-cycling or for correct disposal.



The exchangers treated with surface protection paint, even if protected again corrosion, must anyway be periodically inspected (never more frequently than 6 months under non-aggressive operating conditions, 3 months otherwise) to check the real condition of the surface protection. If it has been scratched or totally or partially damaged, the uncovered area must be once more protected with a new protective treatment.



If the unit is installed in strongly windy areas, near coasts or deserts or in areas subjects to wind and/or sand storms, inspect the unit more frequently (every three months) to check the real condition of the surface protection.

4.16 Electric connections: preliminary safety information

The electrical panel is located in the upper part of the unit on the front side opposite the hydraulic connections. To access the electrical panel, open the hatch using a dedicated key.



Power connections must be made in accordance to the wiring diagram enclosed with the unit and in accordance to the norms in force.



Make sure the power supply upstream of the unit is (blocked with a switch). Check that the main switch handle is padlocked and it is applied on the handle a visible sign of warning not to operate.



It must be verified that electric supply is corresponding to the unit electric nominal data (tension, phases, frequency) reported on the label in the front panel of the unit.



Power cable and line protection must be sized according to the specification reported on the form of the wiring diagram enclosed with the unit.



The cable section must be commensurate with the calibration of the system-side protection and must take into account all the factors that may influence (temperature, type of insulation, length, etc.).



Power supply must respect the reported tolerances and limits: If those tolerances should not be respected, the warranty will be invalidated.



Flow switches must be connected following the indication reported in the wiring diagram. Never bridge flow switches connections in the terminal board. Guarantee will be invalidated if connections are altered or not properly made.



Make all connections to ground provided by law and legislation.



Before any service operation on the unit, be sure that the electric supply is disconnected.



The power line and the unit external safety devices must be sized in order to ensure the correct voltage at the maximum operating conditions of the unit reported in the wiring diagram of the unit.



FROST PROTECTION

If opened, the main switch cuts the power off to any electric heater and antifreeze device supplied with the unit, including the compressor crankcase heaters. The main switch should only be disconnected for cleaning, maintenance or unit repair.

The unit must be powered by a 4-wire cable (3 phases + GND), the power supply is 400 V/3PH/50 Hz. Connect the phases to the input clamp of the main switch and the ground conductor to the dedicated clamp. Use a power supply cable with suitable section and as short as possible to avoid voltage drops. Protect the power supply cable upstream the unit by means of an automatic switch with suitable size and features. The power supply cable section and the automatic switch size, are indicated in the paragraph dedicated to electrical data. The cable entry is shown in the dimensional drawing of the unit attached to the Handbook. It must be suitably protected in compliance with the local regulations in force. If the power supply cable entry is from the top, make a drop-break fold.



Before anyhow intervene on the unit, slightly verify that the electrical circuits of the device have not been damaged during the transport. Especially check that all the screws of the clamps are correctly tightened, and that the cable insulation is intact and in good conditions.

The conductors for the phases power supply cable, must be connected to the free clamps to the unit main switch entry; the ground conductor must be connected to the dedicated pre-arranged clamp (PE).

4.16.1 Connection of power cables

Each unit must be powered by its own dedicated power cable coming from the electrical substation or from a general power concentrator panel that can be positioned near the units and that can be supplied on request in "KP5 or KP10" kits. In particular, in the case of a modular configuration, it is advisable to set up a single power supply dorsal system, for example by creating a dedicated duct, along the front side of the modular system below the support surface of the units. Doing so, if it is necessary to extract one of the modules from the system, this can be achieved by disconnecting it electrically and hydraulically disconnecting the individual module in question, allowing all the others to continue the service.

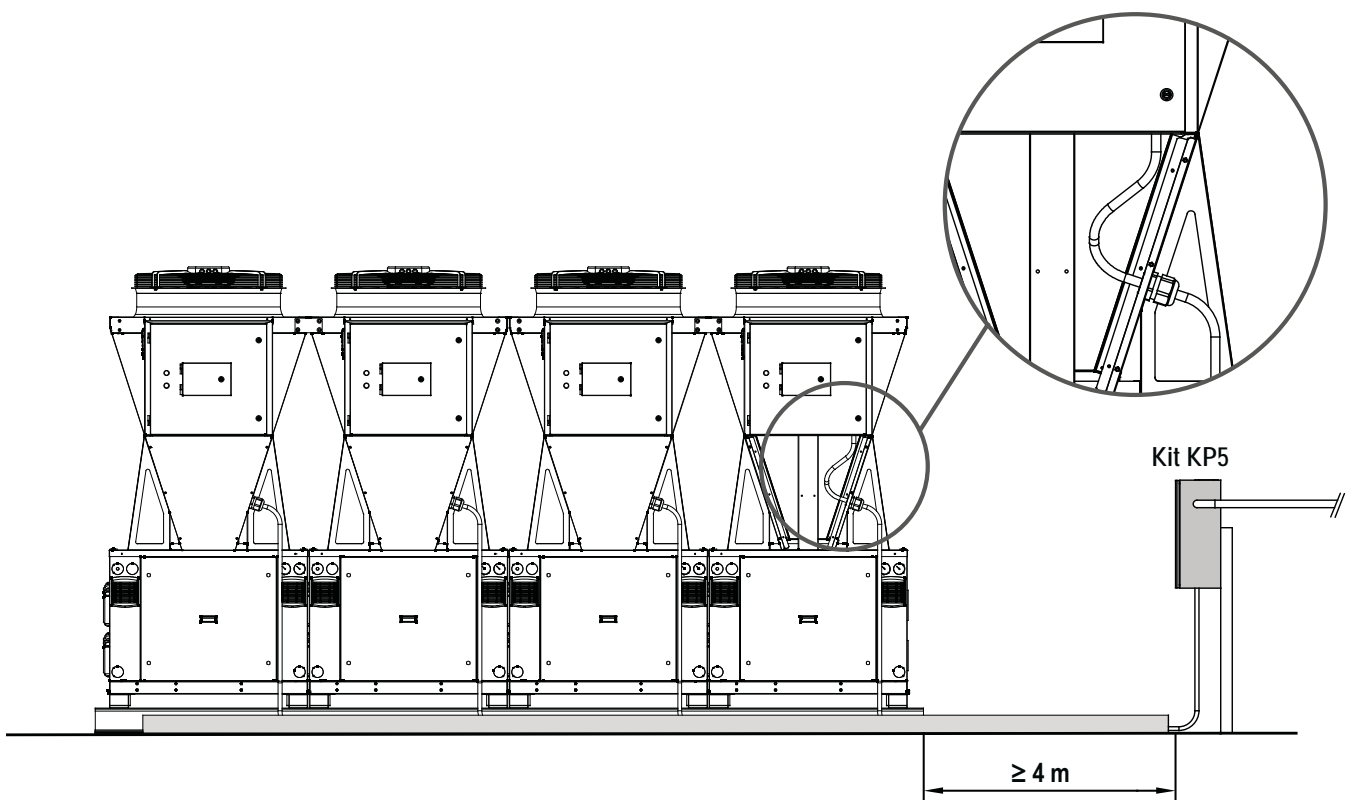

The electrical power cables must be physically separated from the mains and signal cables.

4.17 Connection of mains cables between multiple units

If the system involves the installation of a modular system then it is necessary to place the individual units in communication with each other. For this purpose, a gateway panel must be used ("KG5" kit if the system consists of 2 to 5 units, or "KG10" kit if the system consists of 6 to 10 units) to which each of the units present must connect through a data cable of the RJ45 ETHERNET type.



It is advisable to install the "KG5 or KG10" kit on one of the two units outside the modular system. In this case, the removal of one of them from the system does not involve the rebuilding of the network cables of the other units present.

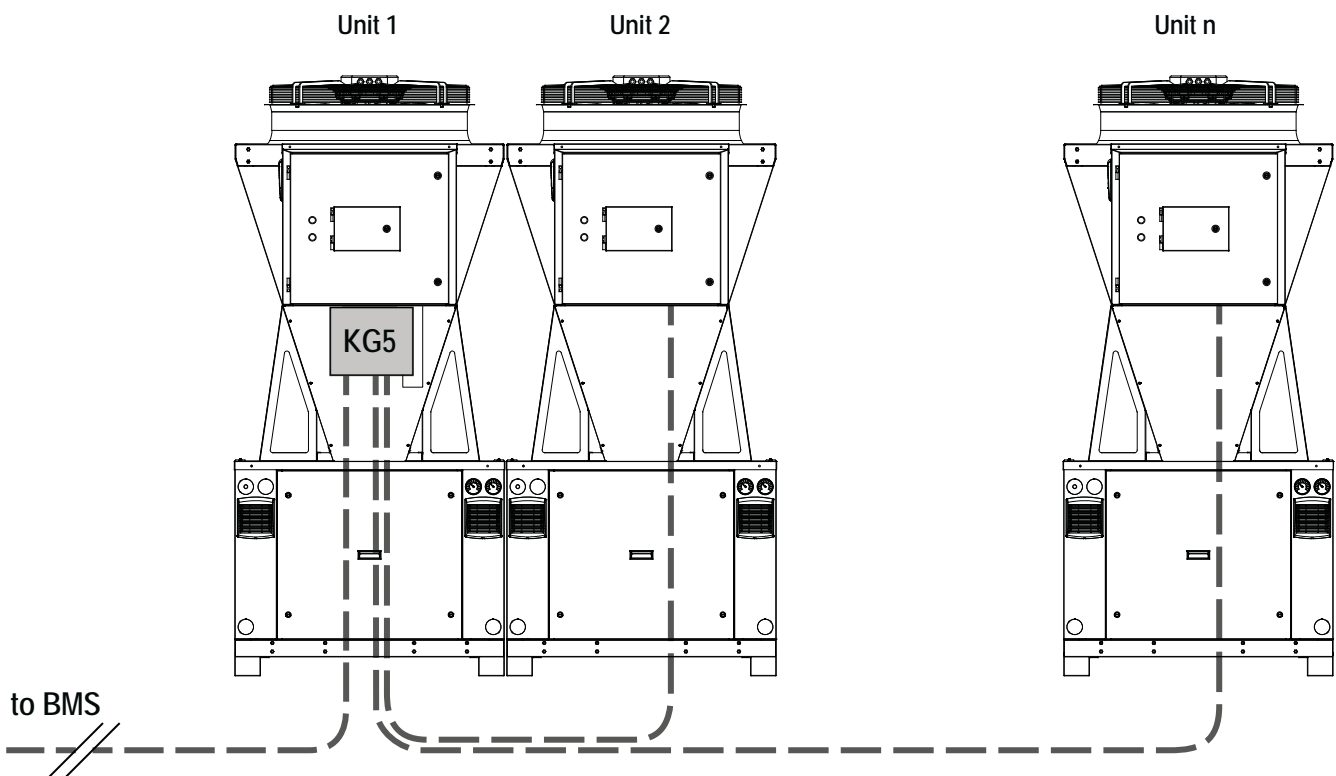

For each of the units constituting the modular system it is necessary to provide a network cable that connects the Ethernet port of the controller on the machine to one of the ports present in the switch installed inside the "KG5 or KG10" kit that collects all the network cables of the system.



The supply and construction of cables for data transmission is the responsibility of the Installer.



The data cable to be used must be suitable for external installations UV-resistant and in any case suitable for the environmental conditions envisaged at the installation site.



A non-inverting Ethernet cable of at least category 6 (or 6a in the case of lengths of more than 50 metres) is recommended.

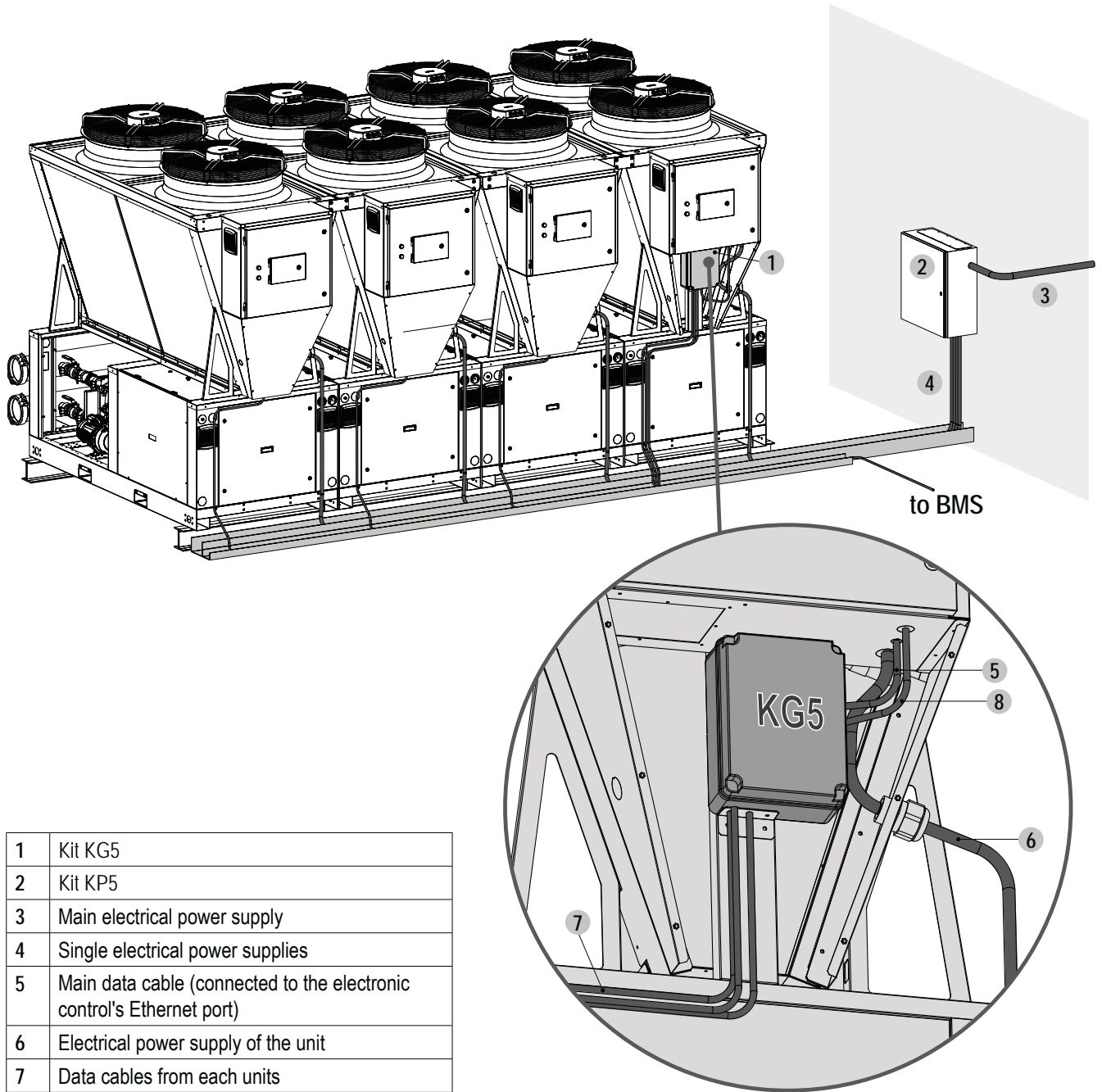

1	Kit KG5
2	Kit KP5
3	Main electrical power supply
4	Single electrical power supplies
5	Main data cable (connected to the electronic control's Ethernet port)
6	Electrical power supply of the unit
7	Data cables from each units
8	Electrical power supply of KG5 Kit



The data cables must be physically divided by the power cables. It is necessary to create a dedicated duct to avoid malfunctions due to electromagnetic disturbances.



For detailed information on the assembly and wiring of the gateway panel refer to the dedicated instruction sheet.

4.18 Electric data



The electrical data reported below refer to the standard unit without accessories. In all other cases refer to the data reported in the attached electrical wiring diagrams.



The line voltage fluctuations can not be more than $\pm 10\%$ of the nominal value, while the voltage unbalance between one phase and another can not exceed 2%. If those tolerances should not be respected, please contact our Company. The use of the unit with a power supply with higher variations than those indicated will invalidate the warranty.

EVEREST290		PAE 881 Kp	PAE 881 WA Kp	GPE 881 Kp
Power supply	V/~ / Hz	400/3/50 + GDN	400/3/50 + GDN	400/3/50 + GDN
Control board	V	24	24	24
Auxiliary circuit	V/~ - V	230/1-24	230/1-24	230/1-24
Fans power supply	V/~	400/3	400/3	400/3
Line section	mm ²	25	25	25
PE section	mm ²	16	16	16
Main switch	A	80	80	80
	-	3 poles	3 poles	3 poles
	Curve	"D"	"D"	"D"

In the case of a modular system, the electrical cables that exit the power concentrator panel (opt. KP5 / KP10) going towards the substation must have the following minimum sections:

EVEREST290 combined modules	n°	2	3	4	5	6	7	8	9	10
Line section	mm	70	120	150	2x120	2x150	2x150	2x185	3x150	3x185
PE section	mm	50	70	95	2x70	2x95	2x95	2x120	2x120	2x150



Electric data may change for updating without notice. It is therefore necessary to refer always to the wiring diagram present in the units.

5. UNIT START UP

5.1 Preliminary checks

Before starting the unit the checks detailed in this manual of the electric supply and connections, the hydraulic system and the refrigerant circuit, should be performed.



Start-up operations must be performed in accordance with the instructions detailed in the previous paragraphs.



If it is required to switch the unit on and off, never do this using the main isolator: this should only be used to disconnect the unit from the power supply when the unit is to be permanently off. Isolation will result in no supply for the crankcase heater and on start up the compressor could be seriously damaged.

5.1.1 Before start-up



Damage can occur during shipment or installation. It is recommended that a detailed check is made, before the installation of the unit, for possible refrigerant leakages caused by breakage of capillaries, pressure switch connections, tampering of the refrigerant pipework, vibration during transport or general abuse suffered by the unit.

- Verify that the unit is installed in a workmanlike manner and in accordance with the guidelines in this manual.
- Check that all power cables are properly connected and all terminals are correctly fixed.
- The operating voltage between phases R S T is the one shown on the unit labels.
- Check that the unit is connected to the system earth.
- Check that there is no refrigerant leakage.
- Check for oil stains, sign of a possible leak.
- Check that the refrigerant circuit shows the correct standing pressure on the pressure gauges (if present) otherwise use external ones.
- Check that the Schrader port caps are the correct type and are tightly closed.
- Check that crankcase heaters are powered correctly (if present).
- Check that all water connections are properly installed and all indications on unit labels are observed.
- The system must be flushed, filled and vented in order to eliminate any air.
- Check that the water temperatures are within the operation limits reported in the manual.
- Before start up check that all panels are replaced in the proper position and locked with fastening screws.



Do not modify internal wiring of the unit as this will immediately invalidate the warranty.



Crankcase heaters must be powered at least 12 hours before start up (pre-heating period) To do this, isolate the compressor(s), fans and pump(s) in the electrics box and then switch on the main isolator (heaters are automatically supplied when the main switch is closed). The crankcase heaters are working properly if, after several minutes, the compressor crankcase temperature is about 10÷15°C higher than ambient temperature.



During the 12 hours pre-heating period it is also important to check that the label OFF is shown on the display or that the unit is on stand-by mode. If there is an accidental start-up before the 12 hours pre-heating period has elapsed, the compressors could be seriously damaged and therefore the warranty will immediately terminate .

5.1.2 Commissioning

The unit commissioning must be carried-out by a skilled refrigeration technician authorized by the manufacturer.



Before turning on the unit, please check that the taps located on the discharge and suction pipe of the compressors are open.



After opening the taps located on the compressors, the unit must be immediately turned on.



Before starting the unit for the first time or after a long period of stop, verify that the parameters set on the microprocessor are coherent with the required working conditions.

To switch the device ON, turn the main switch to ON, to power the unit. Then press the ON/OFF key on the microprocessor keyboard, positioning it on ON.

If the remote ON/OFF contact is closed, the circulation water pump, if present, will immediately start. After a delay time, settable by microprocessor, also the fans will start and then the different compressors in relation to the required cooling capacity to satisfy the present thermal load.

Once the unit has reached a stable operation regime, the technicians must verify the group working parameters and verify that:

- a) the safety high pressure switches are right installed and calibrated;
- b) on the external safety valves it is shown the calibration pressure and that the value is the one foreseen.
- c) No refrigerant leakage is present

The collected data must to be recorded on the commissioning report attached to this manual.



A copy of the commissioning report, duly filled, must be sent to the manufacturer, to make the warranty valid.



During the commissioning, the technician must check that the safety (high and low pressure switches, water differential pressure switch, anti-freeze thermostat etc.) and control devices (regulation thermostat, condensation pressure regulation device etc) properly work.

5.1.3 Device and security Set-point

Device		Set-point	Differential	Reset
Cooling mode	°C	12 *	4	----
Heating mode	°C	45 *	4	----
Anti-freeze thermostat	°C	6	4	Manual
Fire prevention safety valve	Bar	25	----	----
High pressure switch compressors stop	Bar	30,5	----	Manual
Low pressure transducer	Bar	3,5	----	Automatic

* Default values.

5.1.4 Controls during unit operation

- Check the rotation of the compressors and fans. If the rotation is incorrect, disconnect the main switch and change over any two phases of the incoming main supply to reverse motor rotation (only for units with three-phase fan motors).
- After several hours of operation, check that the sight glass has a green colour core: if the core is yellow moisture is present in the circuit. In this event it is necessary for dehydration of the circuit to take place. This must be performed by qualified people only. Check that there are no continuous vapour bubbles present at the sight glass. This would indicate a shortage of refrigerant. A few vapour bubbles are acceptable.

5.2 Safety valves

The outlet connections of the safety valves installed on the unit are provided with a threaded connection, which must be connected to a safe area at a height of not less than 4 metres from the condenser or at a distance of at least 4 metres from the machine and any other sources of ignition. If provided, the valves must be directed in metal piping, to an area where the refrigerant spill cannot damage people or things. The piping must be made according to the EN378 and EN13136 regulations and to any regulations in force.



The piping for conveying into a safe area must allow the release of the refrigerant upwards, away from the machine, from potential triggers from doors, windows or other entrances to closed environments.



The refrigerant spilled from safety valves is an high pressure, high temperature and high speed discharged gas. Its flow may damage things and people coming in direct contact with it.



The opening of safety valves comes with a noise whose intensity may damage hearing capabilities of surrounding people.



The representative cone that forms following the opening of the safety valve can expand for more than 10m from the release point.

5.2.1 Connection to safety valves

The units have a safety valve positioned on the low pressure branch.

	Outlet diameter	Intervention pressure
VS Low pressure	1" GM	25 bar

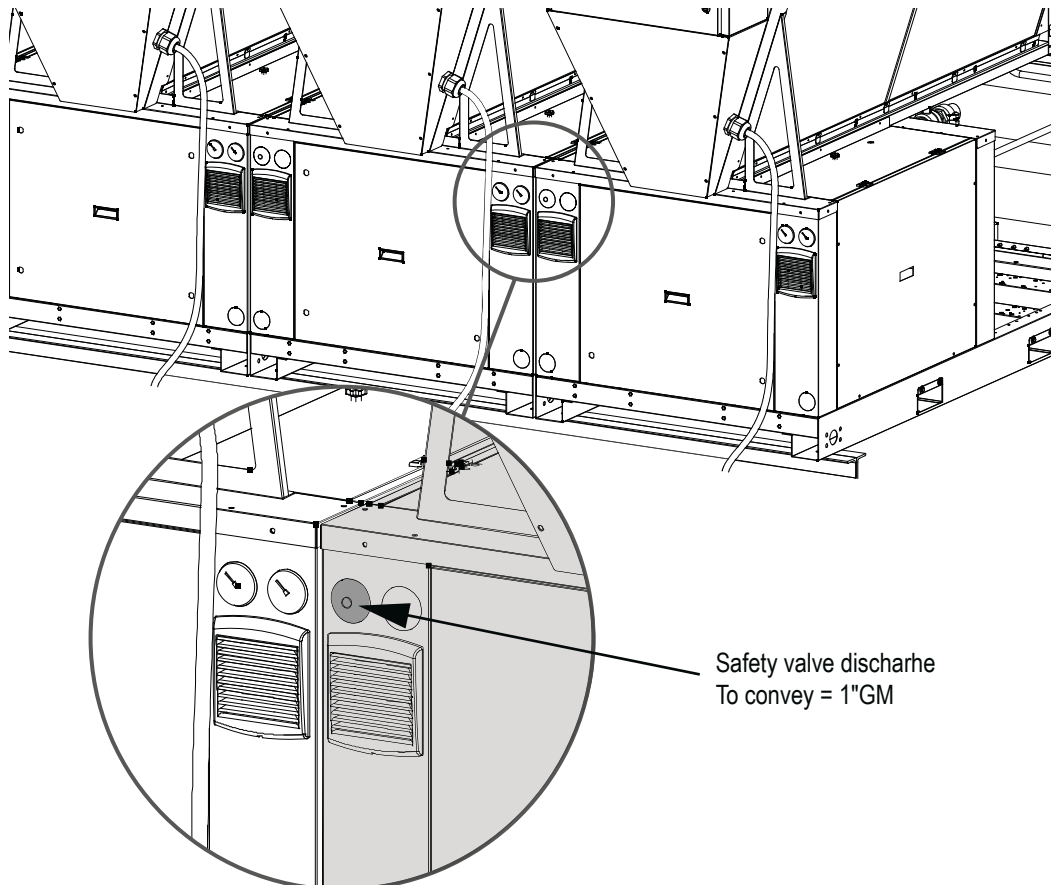



Activation of the safety valve creates an area around the discharge in which a flammable atmosphere can be created. Ensure that there are no obstacles or ignition sources in the cone area below.

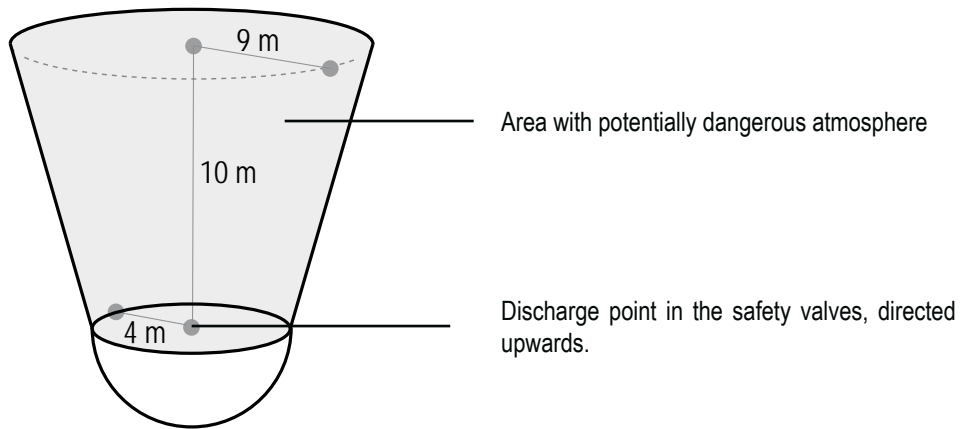

Ice or other natural events must be prevented from obstructing the discharge of the safety valve.

The piping outlet connection must be done so to avoid that rain water, snow, ice, and dirt can accumulate and obstruct the pipeline. The valve discharge must be at a suitable distance from other equipments, systems or ignition sources; the discharged refrigerant must not accidentally enter buildings.

5.3 Description of the control panel

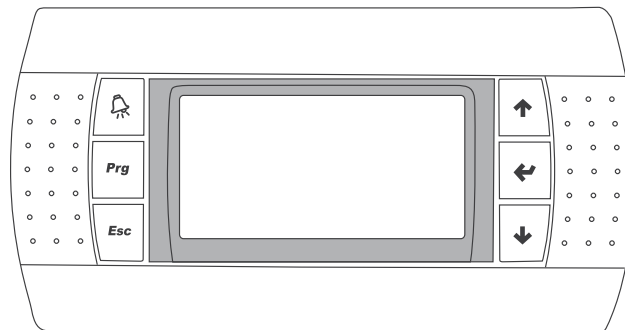

5.3.1 Key function

	AL: Access to the alarm menu.
Prg	PRG: Access to the main menu.
Esc	ESC: Go up one level within the menus.
	UP: Scroll up: on the main screen allows to scroll within the quick menus. Within the menu, it allows to scroll through the screens. In edit mode, it allows to change the settings.
	ENTER: On the main screen, it allows access to the quick menus. Inside the menus, it allows to go down one level in the structure and to confirm the choices with the scroll buttons.
	DOWN: Scroll down. On the main screen, it allows to scroll within the quick menus. Within the menu, it allows to scroll through the screens. In edit mode, it allows to change the settings.

6. USE

6.1 Quick menu

On the main map, scroll with **UP** and **DOWN** to view the following menus:

	ON / OFF: Turn the module on / off
	Info: It allows to view information on the functioning of the module
	Set: Display and modification of the module set points
	Eve: Synoptic of the modular system

6.2 ON / OFF Display

In the main screen, scroll with **UP** and **DOWN** and press **ENTER** once the **ON / OFF** icon is displayed

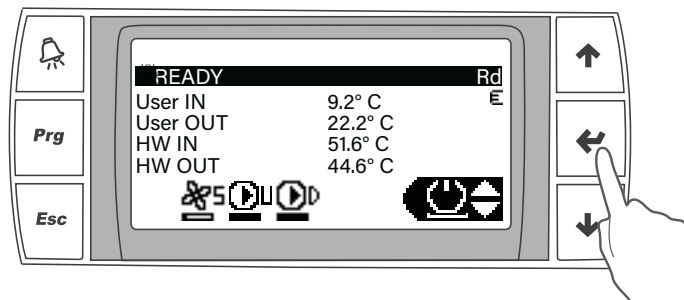

Choose the desired status with **UP** and **DOWN** and press **ENTER** to turn on / off the unit

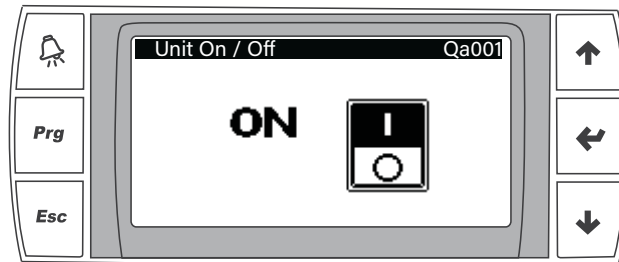

6.3 Info menu

In the main screen, scroll with **UP** and **DOWN** and press **ENTER** once the "i" icon is displayed

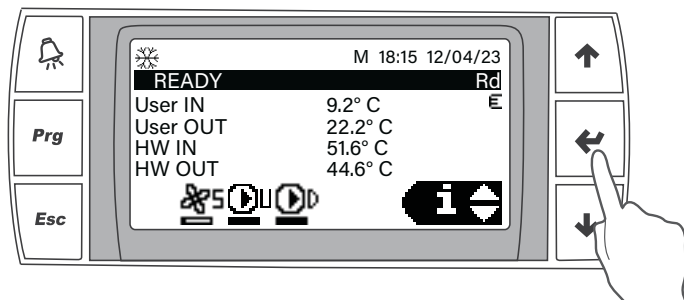

The following variables are displayed in the first mask

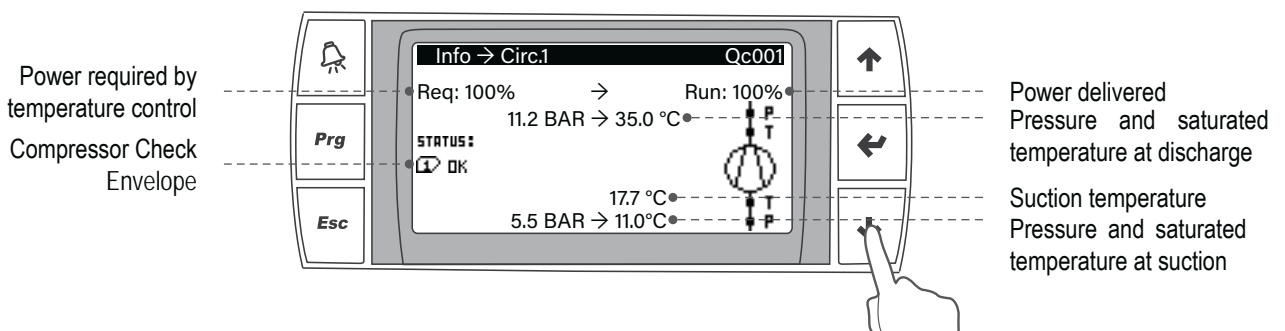

The next screen displays the status of the individual compressors and any counts linked, for example, to the minimum compressor OFF time.

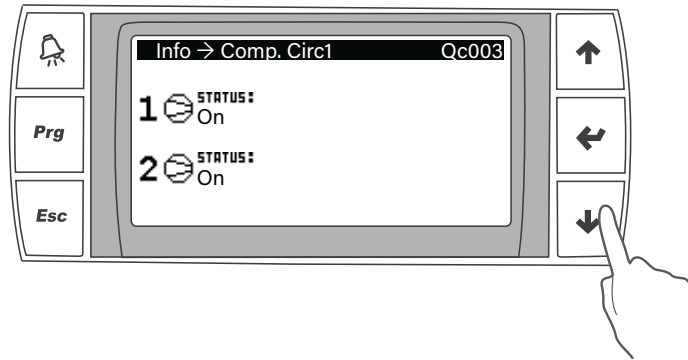

Scrolling further, it is possible to view information relating to the valves such as:

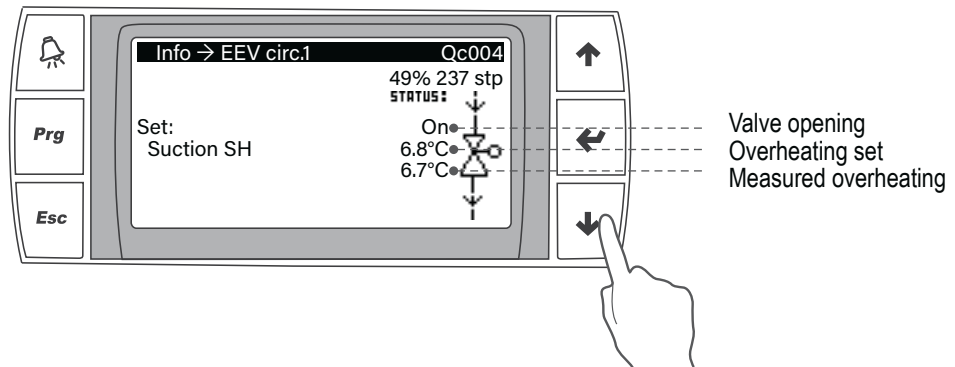

The next screen shows an overview of the external and battery temperatures. Furthermore, other information relating to the unit and its operation is reported.

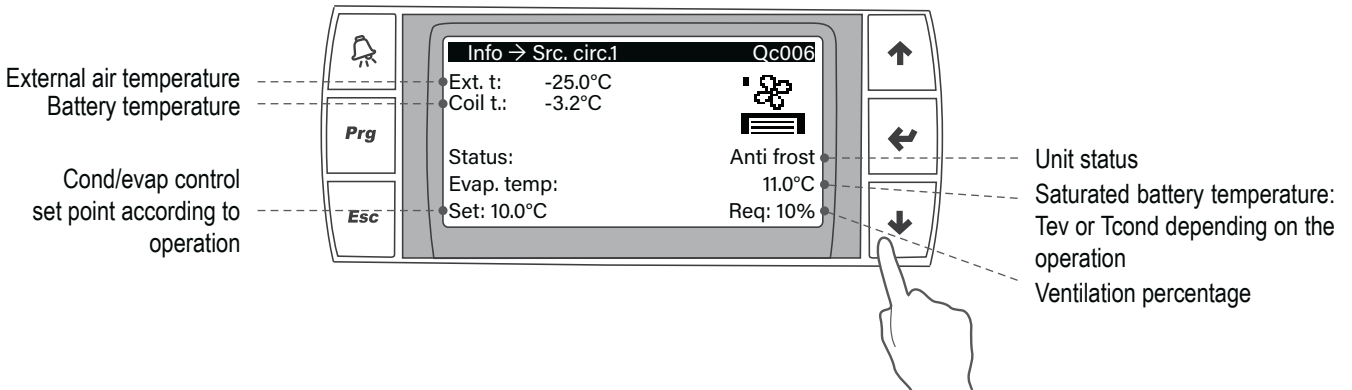

A subsequent screen details the information relating to Defrost

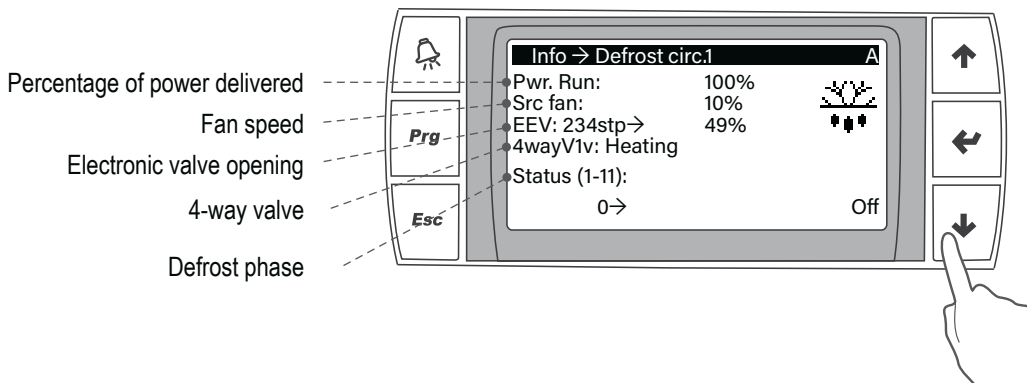

For further details related to the Defrost phases, refer to the Control Manual.

The next screen shows the counts of the defrost times:

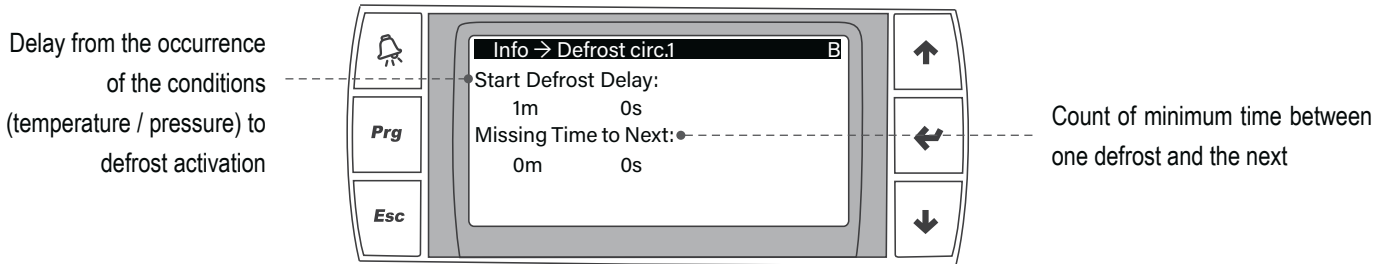

The following screens show in detail the operating conditions of the plant side and recovery side exchangers (in the case of multipurpose units).

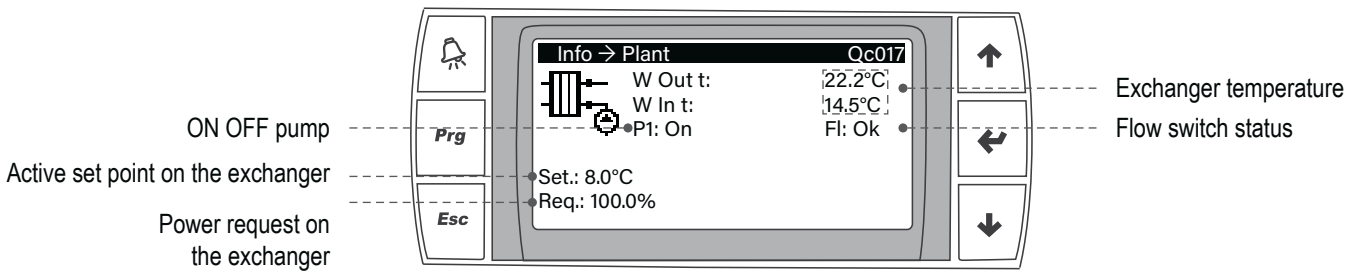

6.4 Set point

In the main screen, scroll with UP and DOWN and press ENTER once the SET icon is displayed

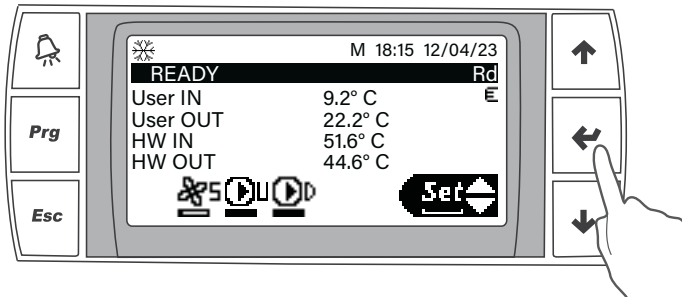

The mask displayed allows to modify the main setpoint.

This setpoint may be different with respect to the active one due to:

- Climatic compensation from external probe
- Activation of second setpoint from Digital Input
- Setpoint activation differentiated by Time Bands

For this reason, the real setpoint actually active on the unit is always displayed below the setting mask.

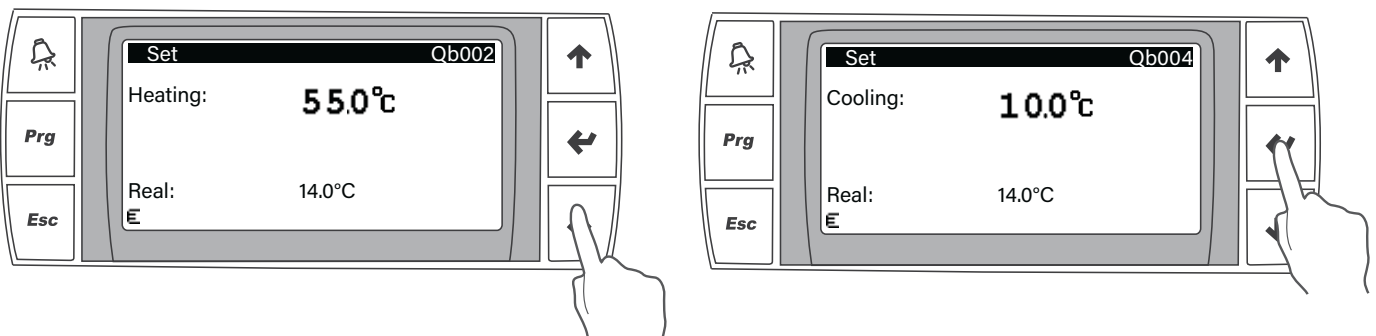

6.5 Everest: synoptic of the modular system

In the main screen, scroll with UP and DOWN and press ENTER once the EVE icon is displayed.

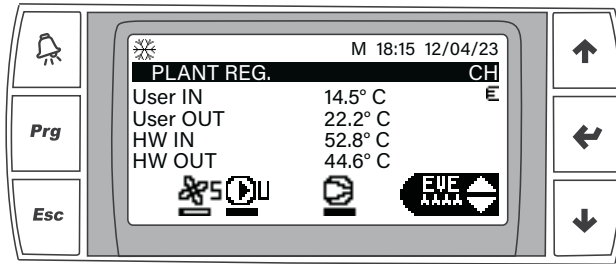

To view the complete the modular system, it is necessary to log in to the Master module. The following mask indicates which unit is being viewed.

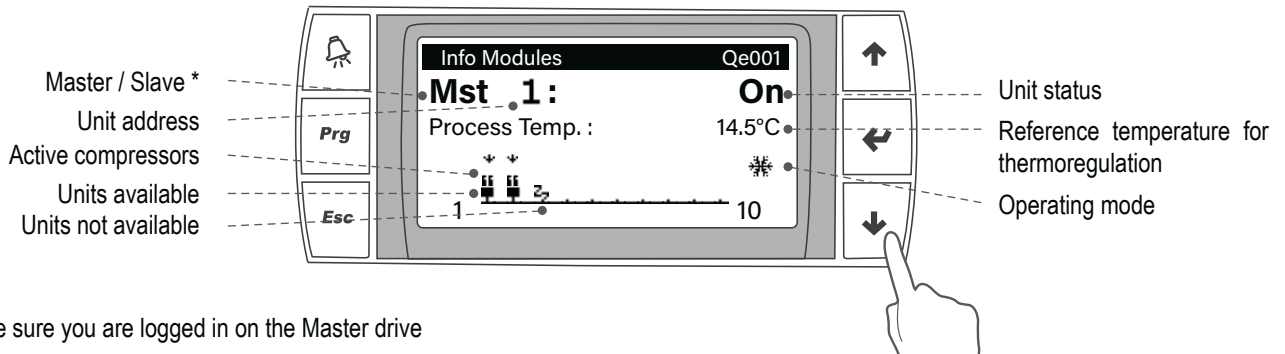

* Make sure you are logged in on the Master drive

Below, you can view the average operating hours of the individual units

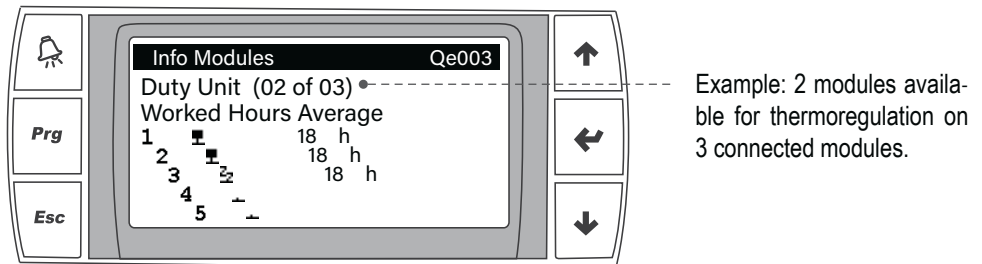

6.5.1 Icon legend for module

	Not present		Offline
	On		Initialisation
	Stand-by		Off
	Alarm		Temporarily unavailable for temperature controls

6.5.2 ON / OFF conditions

L'unità può essere attivata / disattivata tramite tastiera (come da precedente paragrafo) o attraverso le modalità descritte di seguito. In caso siano abilitati più metodi per effettuare l'ON OFF unità è necessario che tutte le condizioni siano soddisfatte perché l'unità sia ON. In caso anche uno solo dei segnali sia impostato su OFF l'unità resterà spenta.

- From digital input

If ON OFF is enabled from the digital input, the unit will be enabled for operation with the contact closed and inhibited (regardless of the ON OFF status from the keyboard, Time Bands, Supervision) if the contact is open.

- By Time Bands

The unit can be switched off using Time Bands if the function is enabled. Refer to the appropriate paragraph for this programming.

- From Serial Communication

The unit can be switched off via the special register in serial communication.

6.6 Access to the main menu

In the main screen, press the PRG button to access the menus

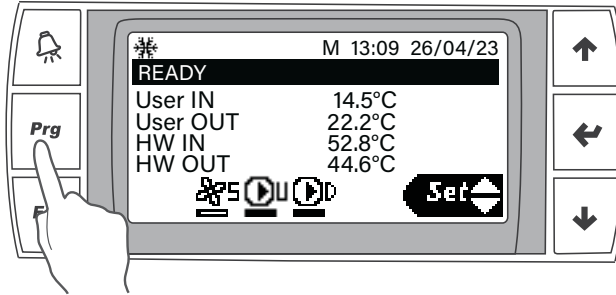

Enter the dedicated password to enable the menus linked to your profile.

To enter the password, scroll with UP and DOWN and press ENTER when the digit is correct to move on to the next one.

User Password is 0001

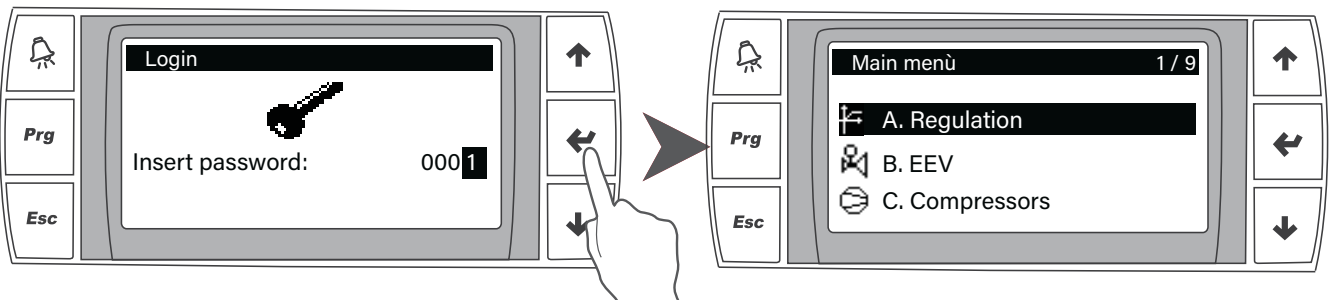

Within the main menu structure (Main menu) it is possible to move with UP and DOWN and press ENTER to enter the submenus and finally modify the parameters; press ESC to go back to the upper level of the submenu. This procedure is valid for the entire structure. At the end of the parameter, modification it is necessary to execute the Logout from the appropriate item. Once you have entered the logout submenu, press ENTER to confirm the exit.

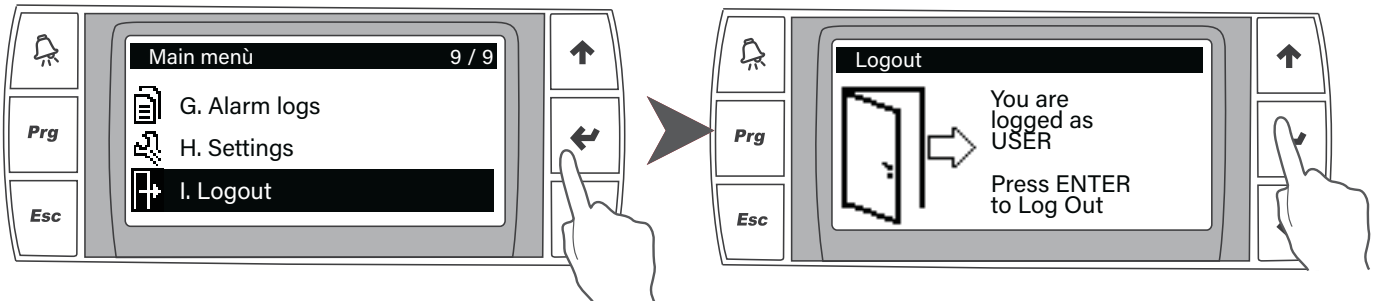

Exceptions:

- If you try to modify a parameter that cannot be accessed at User level, the control will request a higher level password and will prevent the modification by preventing dangerous tampering.

The screens show, at the top left, the indication of the password level required to modify the parameters shown:

M = manufacturer password (Manufacturer password)

S = service password (Service password)

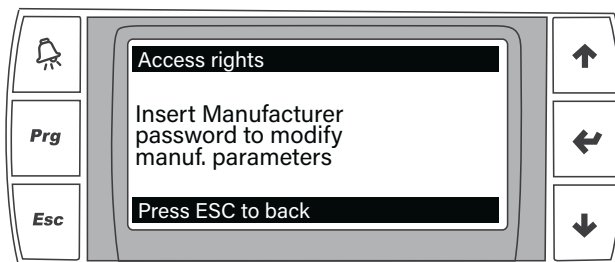

• Depending on the configuration of the unit (carried out at Manufacturer level and modifiable only by the manufacturer) some screens will not be used within the menu. It is possible that the numbering of the masks (top right) is not perfectly sequential.

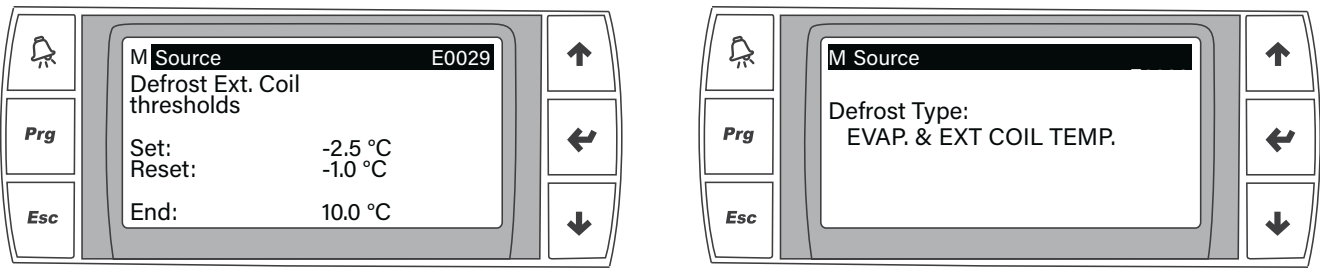

6.7 Time bands

6.7.1 Time bands settings

The control allows to set up to 4 daily time bands.

If several units are connected, the time bands are set and managed only on the Master.

The time bands can be set from the main menu.

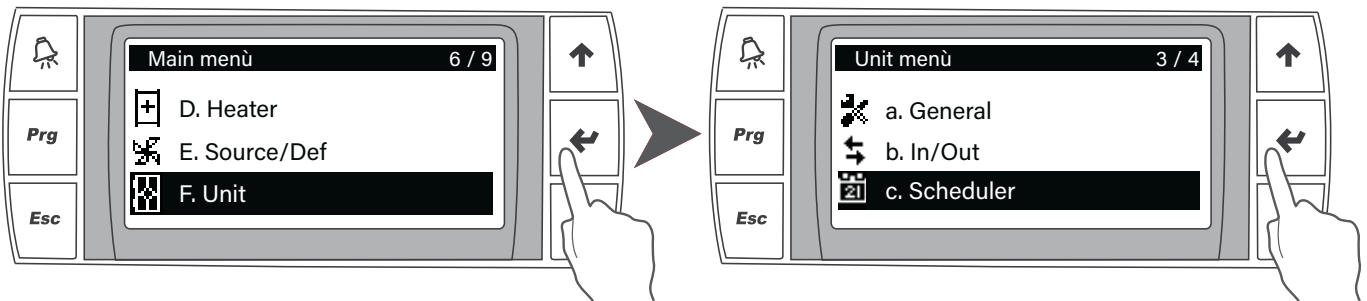

From time bands it is possible to set one of the following operating modes for the unit:

- OFF from time band
- ON with Setpoint Comfort
- ON with Pre-Comfort Setpoint
- ON with Eco Setpoint

The hourly scheduling can be differentiated according to the individual days of the week.

The definition of the 3 different types of set point is detailed in the following paragraph.

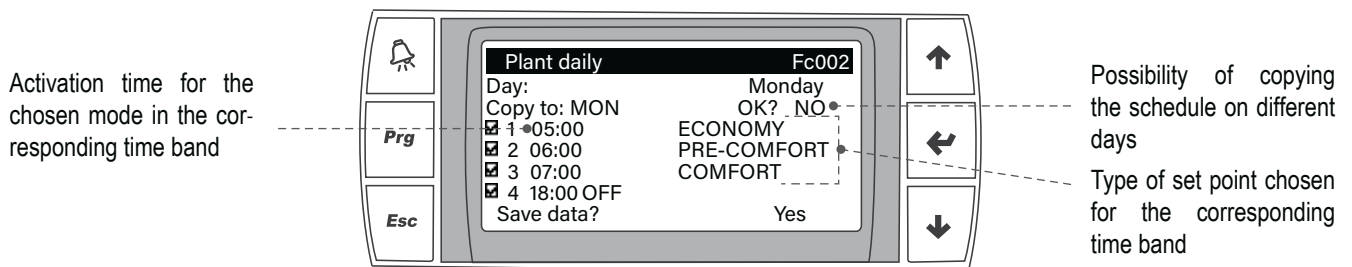

6.7.2 Set point from time bands

If the time bands are enabled, it is possible to set 3 different set points by entering the main menu.

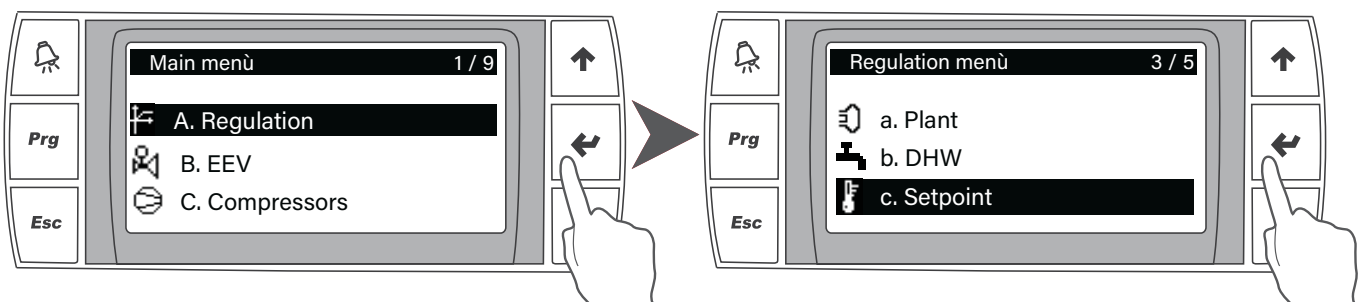

With **UP** and **DOWN** select the set to modify and press **ENTER** to confirm.

Use **UP** and **DOWN** to modify the parameter until the desired value is reached, then press **ENTER** again to confirm.

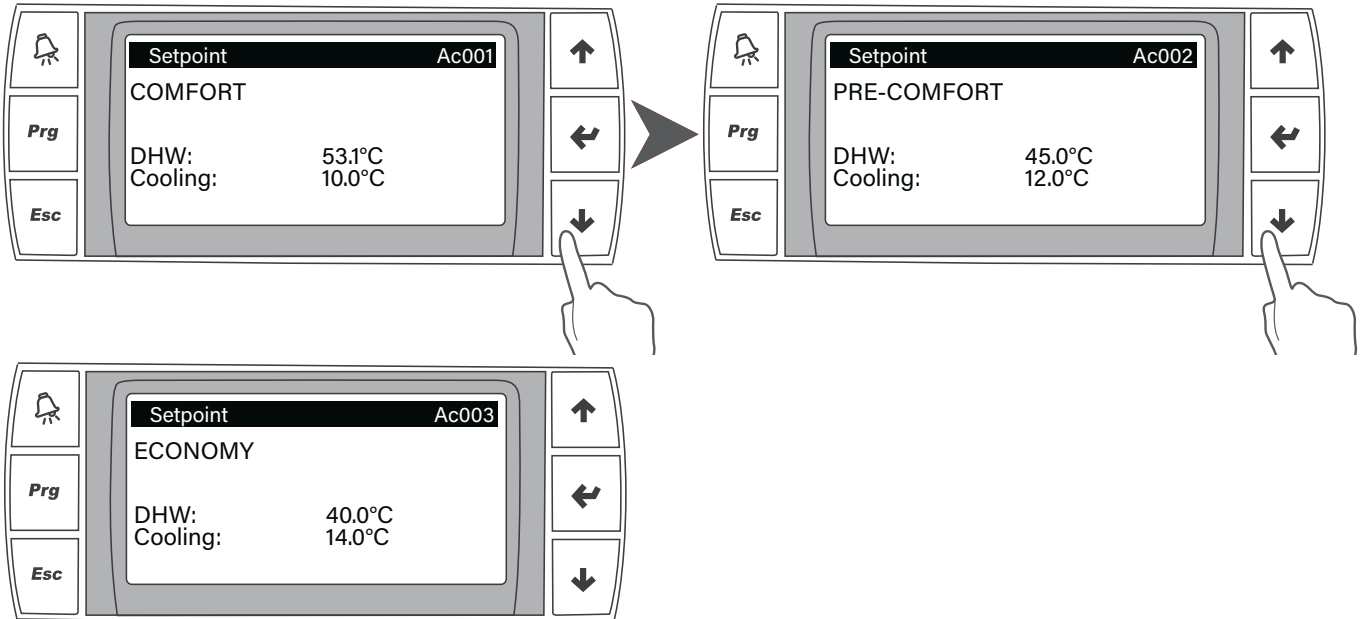

6.8 Second Set Point from ID

In the adjustment menu it is possible to set an offset with respect to the main set point on the User side and on the HW side (in the case of multi-purpose units) which can be activated from a digital input.

Press **PRG**, select the "A. Regulation" menu and then "a.plant" and press **ENTER**, scroll with **DOWN** to the desired screen then press **ENTER** to enter the preferences modification mode.

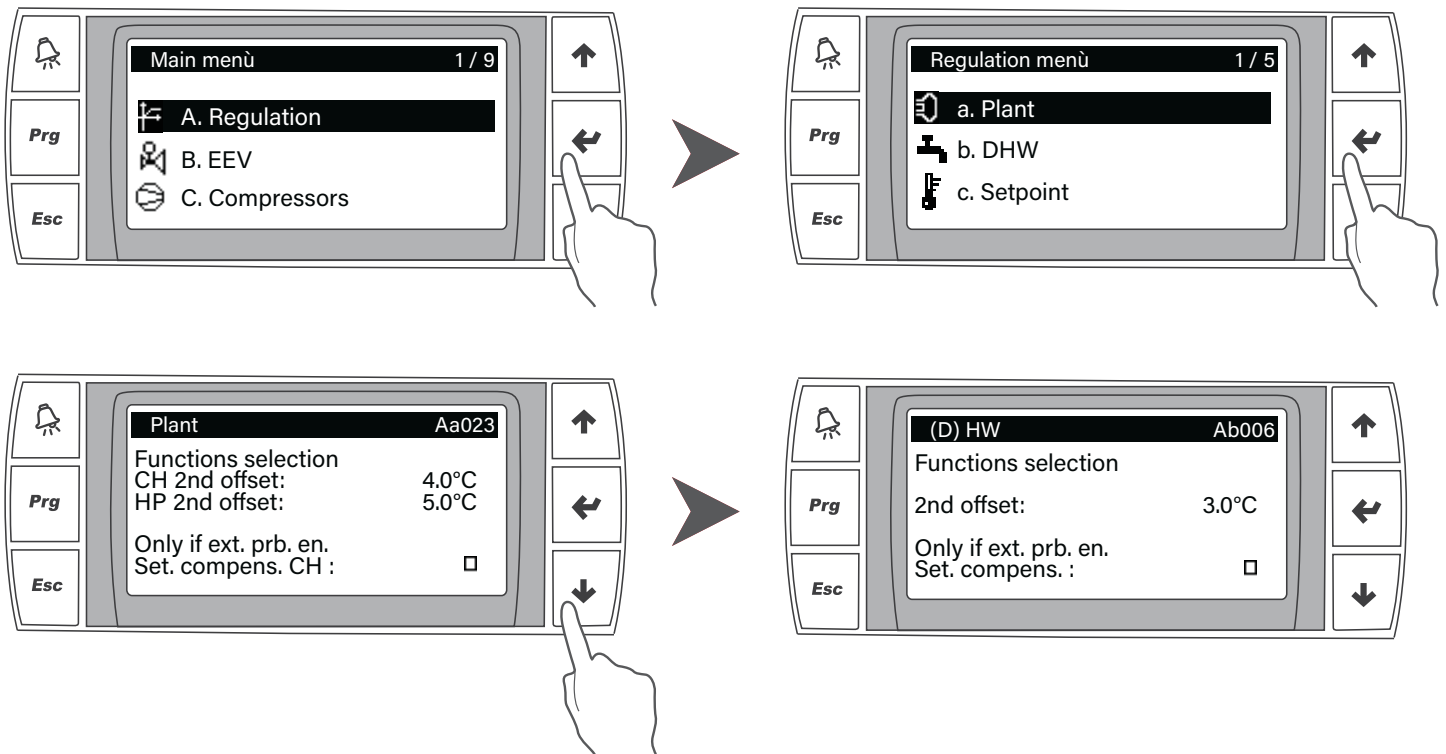

When the digital input is open, the unit operates with the main setpoint, when the digital input is closed the unit applies the set offset to the main setpoint.

Refer to the wiring diagram to identify the digital inputs involved.

6.9 I/O

6.9.1 General

Access to the Input / Output menu allows to view the current status of the inputs and outputs connected to the command. Press PRG, select the "F. Unit" menu and then "b. In/Out" and press ENTER; with DOWN, scroll through the available screens.

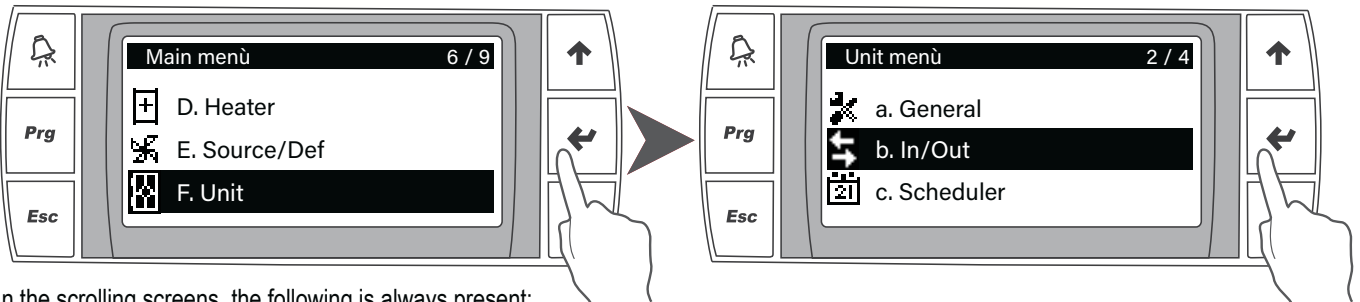

In the scrolling screens, the following is always present:

- A first selection shows an overview of:
 - Digital inputs
 - Digital outputs
 - Analogue inputs
 - Analogue outputs
- The single detail screens relating to the single inputs and outputs with the value and the respective use on the controller.

6.9.2 Digital inputs

In the Fb001 screen it is possible to view the individual digital inputs (identifiable on the wiring diagram) and the respective OP (Open) / CL (Close) status.

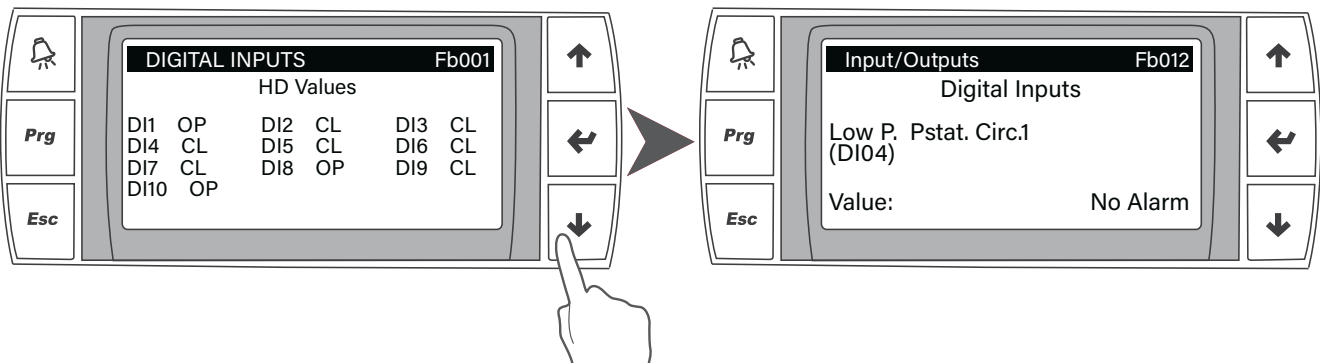

In the following screens, each single digital input is examined and, in addition to the status, the use assigned to it in the control is specified.

6.9.3 Digital outputs

In the Fb100 screen, it is possible to have an overview of all the digital outputs and the respective OP (Open) / CL (Close) statuses.

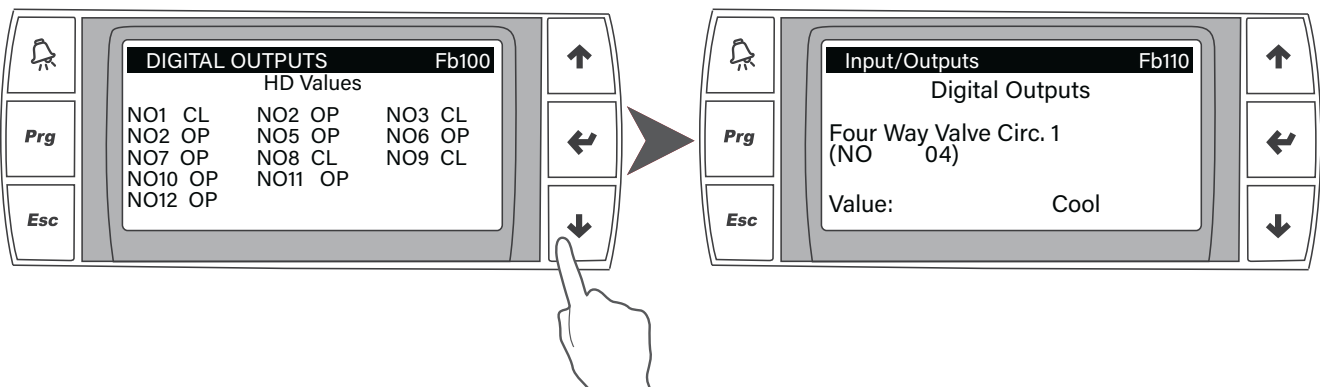

The following screens detail the status and use of each individual digital output.

6.9.4 Analogue inputs

In the Fb200 screen, it is possible to have an overview of all the analogue inputs and the respective reading values based on what is connected to them.

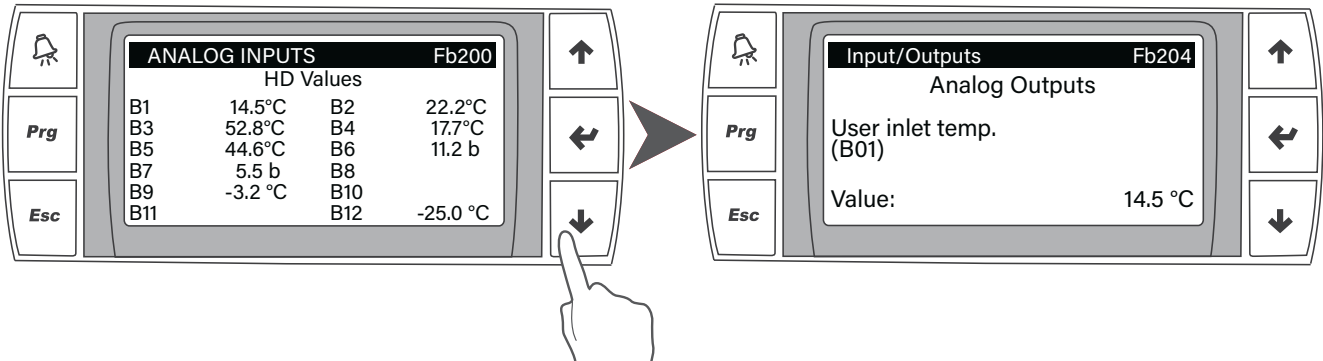

The following screens detail the status and use of each single analogue input.

6.9.5 Analogue outputs

In the Fb300 screen, it is possible to have an overview of all the analogue outputs and the respective reading values based on what is connected to them.

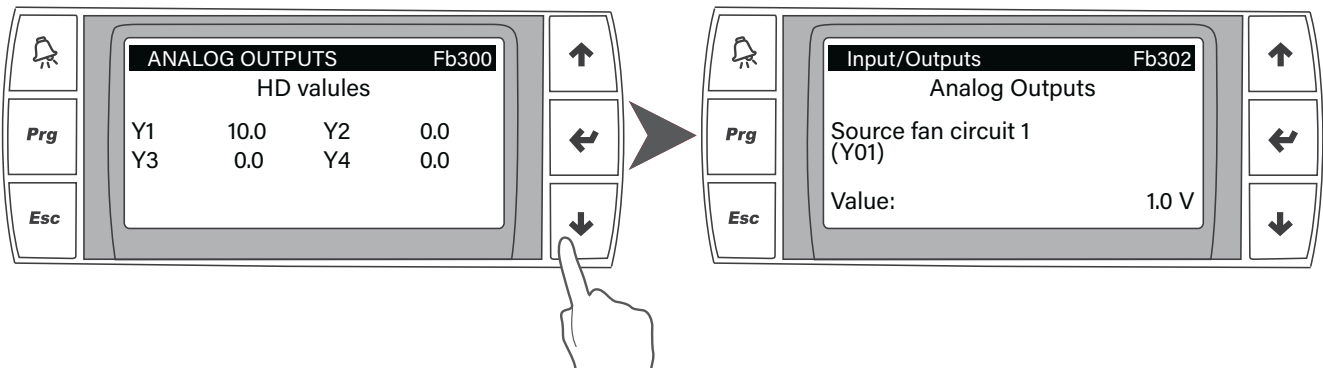

The following screens detail the status and use of each individual analogue output.

6.10 Module control functions

6.10.1 Intelligent working point control

The system constantly monitors the duty point of the compressor based on the evaporating and condensing pressures.

6.10.2 Ventilation

Ventilation is modulated in summer and winter mode in order to minimise energy consumption and allow the compressor to always operate within the working range. The fans will be accelerated to the maximum speed allowed:

- in the chiller with operation at the maximum external temperatures
- in heat pump with operation at minimum external temperatures

6.10.3 Valves

The electronic valves are modulated in order to operate a further control with respect to the working point.

In particular, the opening will be increased if the pressure drops excessively (LOP) and the closing if the pressure rises excessively (MOP).

6.10.4 Compressors

The control constantly monitors the evaporation and condensing pressures and is able to activate some prevention logics (based on the intervention area) to bring the compressor back to operating within the wrapping:

Possible actions are a combination of one or more of the following:

- slowing down the increase or reduction in power required by delaying the start or stop of a compressor;
- increase in power supplied by hooking up a compressor;
- reduction of the power supplied with the release of a compressor;
- modification of the parameters of the electronic valves in order to induce a variation of the compression ratio

The control algorithm is therefore able to guarantee the correct functioning of the unit even in the most extreme conditions of the work field.

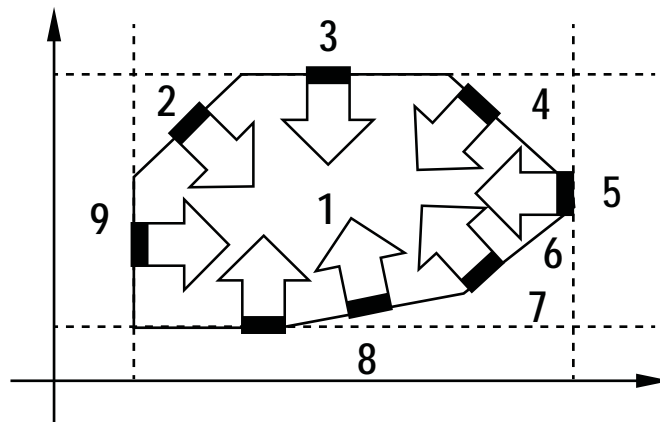

6.10.5 Double electronic expansion valve

Each Everest module is equipped with a double electronic expansion valve.

The algorithm integrated in the control is able to predictively choose whether to operate with one or two electronic valves, guaranteeing perfect lamination and control of the refrigerant flow in any working condition and at any thermal load.

6.10.6 Advanced defrost logic

The unit is able to detect the coil frosting conditions by combining the working pressures and the temperature detected in strategic positions of the circuit. When the defrost is activated, the single unit switches off the compressors and reverses the cycle by reactivating the compressors to condense on the coil (thawing the fins) and cooling the water on the branch of the system on which hot water was produced (HW in the case of the multi-purpose unit).

During defrosting, the fan can be activated for a short time to control the condensing temperature until the fins are completely cleaned. At the end of defrosting there is a dripping phase, with the compressors off, at the end of which a rapid activation of the fans cleans the surface of the fins, preventing the formation of new ice. At the end the compressors are reactivated and the unit returns to operate in the former conditions.

6.11 Multi-element control functions

It is possible to connect up to 10 Everest modular units.
 These units must be connected mechanically, hydraulically and electronically.

The algorithm implemented inside Everest allows centralised management of the modules in order to maximise the efficiency, stability, reliability and robustness of the system.

6.11.1 Initial Configuration

First of all, during start-up it is necessary to connect the units to the intermediate switch via ethernet cables. Refer to the paragraph “Connecting network cables between multiple units.” Then, through the display on each single module, the units must be configured in order to make serial communication possible. The LAN must be configured as follows.

Press **PRG** and access the “H.Settings” menu, press **ENTER**, scroll to the “d.Serial ports” menu with **DOWN** then press **ENTER** again to confirm.

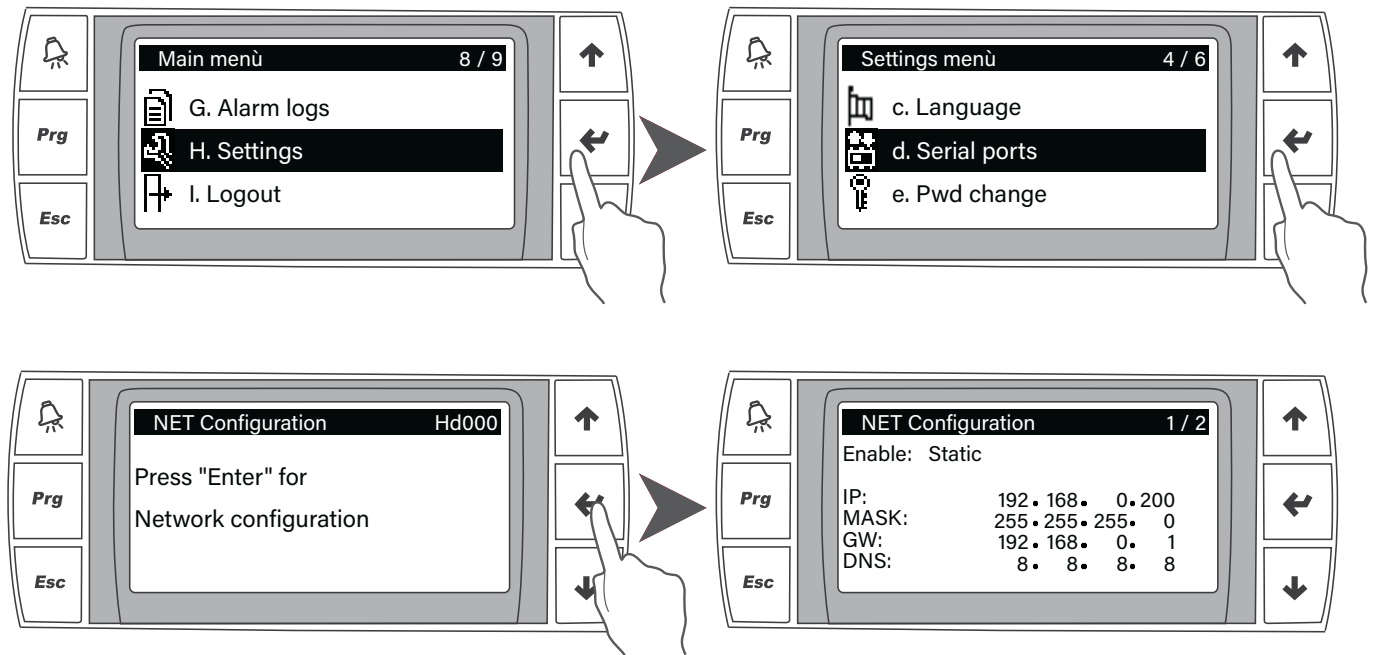

Set static IP making sure the IPs have identical address except the last 3 numbers. Example:

MASTER	SLAVE	SLAVE
Enable: Static	Enable: Static	Enable: Static
IP: 192.168.0.200	IP: 192.168.0.201	IP: 192.168.0.202
MASK: 255.255.255.0	MASK: 255.255.255.0	MASK: 255.255.255.0
GW: 192.168.0.1	GW: 192.168.0.1	GW: 192.168.0.1
DNS: 8.8.8.8	DNS: 8.8.8.8	DNS: 8.8.8.8

The network Master will always be the unit with the lowest IP among those available on the network. If the Master is disconnected from the network, the system is able to react autonomously by assigning the Master function to the next IP among the Everest units connected to the network.



To perform the initial configuration, the unit must have all units turned off but with the controllers powered.



Following a correct configuration of the modular system, the parameters relating to the system regulation must be set on the Master module.

6.11.2 Thermoregulation and pump management

The Master module control constantly communicates with the controls of all the other modules (Slaves) available on the network in order to know their status (ON / OFF / Alarm) and the power available for temperature control.

The temperature used for temperature control is defined as follows:

- If all the units are in standby, this is the return temperature of the Master, the only module to keep the pump active without a load request;
- If there is power supply, it is the average of the return temperatures of the units that have been active for a minimum time (to ensure that the reading is significant).

The Master control defines the compressors that must be activated on the basis of the power required by the system, therefore on the difference between the set point and the control temperature.

The activation logic minimises pumping costs by activating high-efficiency pumps only on the modules that require compressor activation. The partialisation of the flow rate is thus much higher than that obtainable with a single inverter pump and, at the same time, optimal operation of the individual units is guaranteed by ensuring the correct flow rate to the plate heat exchanger in all operating conditions.

6.11.3 Call priority and balancing or saturation logics

The control is able to implement load distribution logics distinguishing between balancing and saturation.

• Balancing

The balancing logic distributes the load among all the units available for temperature control (excluding those kept in standby - see Stabd <>By Rotation logic for selection from the standby rotation logic detailed below).

The call order is defined in order to balance the operating hours of the individual units and will tend to first activate all the units available at partial load, maximising the efficiency of the modular system, and then bring the requested available units to full capacity.

• Saturation

The saturation logic brings each single unit to the maximum available power before activating another one.

In this way, on average, (at the same thermal load) a smaller quantity of active modules is maintained, but with a lower overall efficiency.

In the case of multipurpose units, the advanced logic present in the control will distribute the thermal load with a first balancing logic, if set, but through an advanced algorithm it will tend to attribute the additional load in the other operating mode to the same active modules in order to maximise the opportunities of functioning in total recovery.

In this way, it is possible to guarantee a further increase in the efficiency of the modular system, thus being able to choose when to distribute a single load and when to concentrate the request for cold and hot loads to minimise energy consumption.

6.11.4 Standby rotation

For all applications where the thermal load must be guaranteed even in the event of accidental events, the control allows to define how many modules to make available for thermoregulation and how many to keep in standby, activating them in the event of an alarm from one or more units. In order to ensure correct reactivity and to balance the operating hours of the individual modules, the controller must swap the available units and those in standby, always maintaining the same number of active modules.

6.11.5 Communication failure and unit alarm

The main control requires continuous communication between the Master module and the individual Slaves.

If one or more units lose communication, the control will reconsider the units actually available by distributing the load among those actually available.

The same occurs in the event of an alarm of one or more units: these units are excluded from the count of modules actually available to support the thermal load and the load is redistributed accordingly; if backup units with standby-rotation logic are available, these units are immediately activated.

In the event that the Master unit loses communication, the Modular System will reassign the role to the unit with the next address, delegating control of the System to it. Continuous updating of the essential regulation parameters ensures that the unit that becomes Master can manage the regulation of the modules without any interruption or variation of service to the system.

7. MAINTENANCE OF THE UNIT

7.1 General warnings



Starting from 01/01/2016 the new European Regulation 517_2014, "Obligations concerning the containment, use, recovery and destruction of fluorinated greenhouse gases used in stationary refrigeration, air conditioning and heat pumps", became effective. This unit is subject to the following regulatory obligations, which have to be fulfilled by all operators:

- (a) Keeping the equipment records
- (b) Correct installation, maintenance and repair of equipment
- (c) Leakage control
- (d) Refrigerant recovery and disposal management
- (e) Presentation to the Ministry of the Environment of the annual declaration concerning the atmospheric emissions of fluorinated greenhouse gases.

Maintenance can:

- Keep the equipment operating efficiently
- Prevent failures
- Increase the equipment life



It is advisable to maintain a record book for the unit which details all operations performed on the unit as this will facilitate troubleshooting.



Maintenance must be performed in compliance with all requirements of the previous paragraphs.



Use personal protective equipment required by regulations as compressor casings and discharge pipes are at high temperatures. Coil fins are sharp and present a cutting hazard.



Inside the unit, there can be high voltage zones. Any intervention on them, must be done by authorized personnel qualified in compliance with the local regulations in force.



The surfaces of the components in the compressor discharge side and in the refrigerant liquid line could reach very high temperatures and any contact can cause burns.



Before carrying out any kind of work on the machine, it is necessary to cut off the power supply from the electric panel, by turning the main switch to the OFF position



It is absolutely forbidden to open the refrigerant circuit loaded with refrigerant.



To carry on any intervention requiring the opening of the cooling circuit, follow this procedure:

- 1) activate the crankcase heater of the compressor for 4 hours minimum-
- 2) recover the refrigerant by means of an approved cylinder
- 3) make the vacuum in the circuit
- 4) flow the circuit with inert gas (nitrogen)
- 5) use orbital blades to dissect the pipes



Smoking is forbidden during maintenance operations.

7.2 Drive access

Access to the unit once installed, should only be possible to authorized operators and technicians. The owner of the equipment is the company legal representative, entity or person owns the property where the machine is installed.

They are fully responsible for all safety rules given in this manual and regulations. If it is not possible to prevent access to the machine by outsiders, a fenced area around the machine at least 1.5 meters away from external surfaces in which operators and technicians only can operate, must be provided.

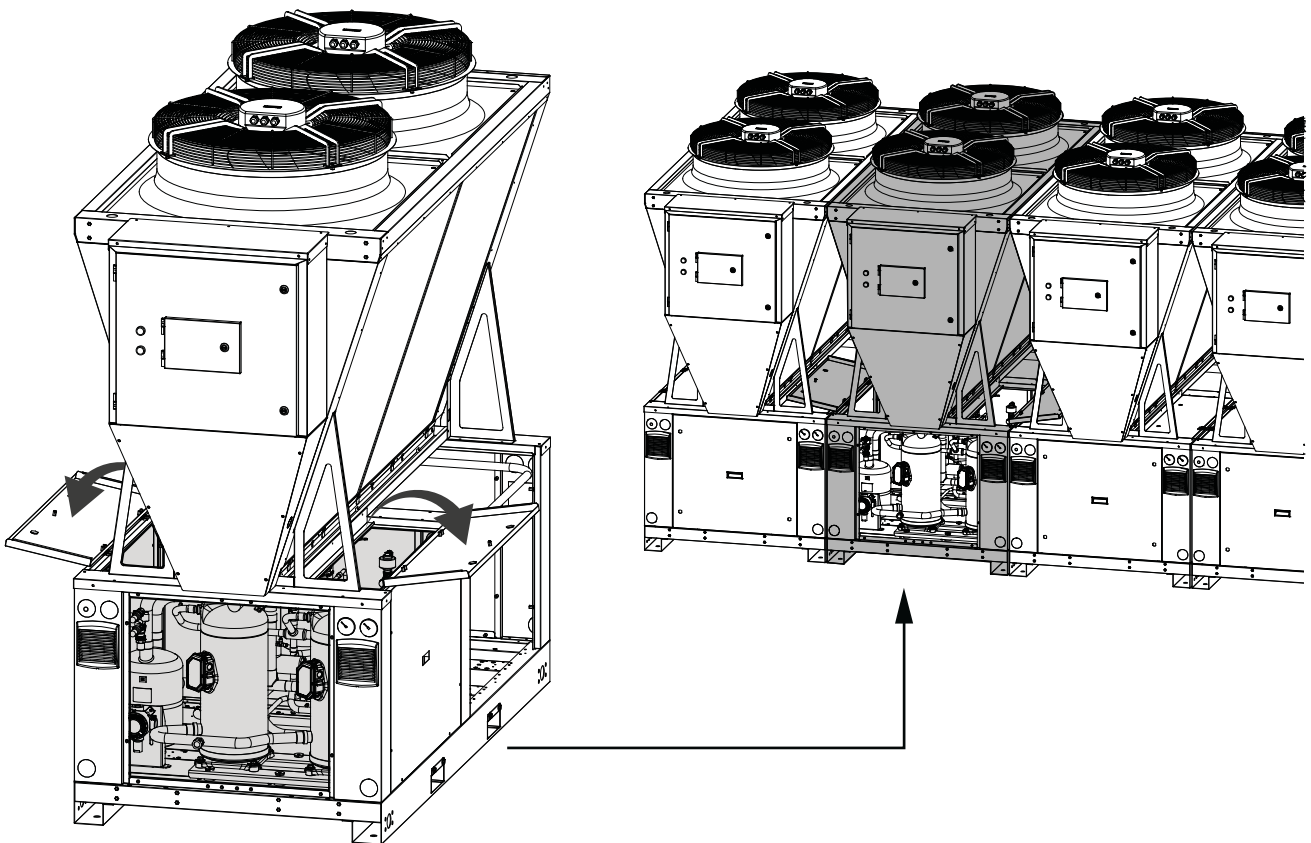

All the main components are accessible from the front for maintenance, both for the single unit and in a modular configuration.



To facilitate checks on valves, coils, lights, connectors, etc., it is possible to open the panels of the technical compartment at the top if the intervention cannot be performed by removing the front panel alone.

7.3 Routine maintenance

The Owner must take care that the unit is adequately maintained, according to the indications contained in the Handbook and what required by current local laws and regulations.

The Owner must take care that the unit is periodically suitably inspected and maintained, according to the system type, size, age and functions and to the indication in the Handbook.



If leak detection instruments are installed on the system, they must be inspected at least once a year, to check that they work properly.

During its operation life the unit must be inspected and checked as stated by the current local laws and regulation. In particular, unless more restrictive specifications, follow the recommendation on the following table (see. EN 378-4. encl. D).

CASE	Sight Inspection (par. 4.2, p.ti a - l)	Pressure test	Leak detection
A	X	X	X
B	X	X	X
C	X		X
D	X		X

A	Inspection, after an intervention, with possible effects on the mechanical resistance or after a change of purpose or after a stop longer than 2 years; all unfit components must be replaced. Do not carry on checks with higher pressures than design ones.
B	Inspection following an intervention, or a relevant modification of the system or its components. The check can be restricted to the components involved in the intervention, but if a refrigerant leak is detected, a leak detection must be made on the all system.
C	Inspection following a change of the unit position. If there is the chance to have effects on the mechanical resistance, refer to point A.
D	Refrigerant leak detection after a justified suspicious. The system must be checked to find any leaks, using direct measures (devices able to find the leak) or indirect ones (deduction of the leak presence analysing the operational parameters), focusing attention on those parts which are more easily exposed to leaks (junctions, for example).



If it is detected a fault that endangers the reliable operation of the unit, it's necessary to rectified it before restart the unit.

7.4 Exceptional Maintenance

7.4.1 Procedure for Vacuum break and Refrigerant Charging



Charging R290 refrigerant is a very difficult operation. If it is not carried out in the correct way, it can cause serious damage to the compressor due to the high miscibility of the oil in the refrigerant, which can lead to the compressor operating without lubricant in the case of large amounts of liquid in the receiver. After the vacuum has been applied to the circuit, the correct procedure consists of the following steps.

1. Vacuum break
 - a. Insert the minimum freon charge at the circuit required to carry out the leak test. Do this by inserting a small charge of refrigerant and allow it to evaporate until the pressure gauge is stable; repeat the procedure until a stable value of at least 2 bar is reached.
 - b. until a stable value of at least 2 bar is reached.
 - c. Proceed to the inspection for any leaks.
2. Control and driver configuration (if required)
 - a. Once the programming has been done, close the electronic thermostatic valves and ensure that the closure is leakproof by the appropriate magnet.



The thermostatic valve closes after driver configuration; if it is only powered, it does not close.

c. Set the unit to summer mode/cold water production (for multifunction units and/or heat pumps).

3. Refrigerant charge

- a. Ensure that the crankcase heater has been switched on for at least 12 hours before starting the charging operation and that the electronic thermostic valves are always closed with the appropriate magnet.
- b. When the compressor is switched off, introduce the minimum charge of refrigerant required for the initial start-up (to avoid activating the low pressure switch). Never charge more than 1/3 of the charge indicated on the plate at this step; apply the charge on the coil liquid line.
- c. Slowly charge the refrigerant above the evaporator until the thermostatic valve begins to operate.
- d. Check and complete the refrigerant charge with the unit fully operating at nominal conditions.

7.4.2 Extraction of a unit from the modular system

It may be the case that one of the units constituting the modular system requires a maintenance intervention necessitating access on the long sides of the unit, inaccessible due to the other adjacent units. In cases such as this, in order to remove the unit to be maintained, it is necessary to intervene on it in the following operating mode:

- Secure the hydraulic part by closing the valves on the delivery and return pipes;
- Remove the Victaulic joints that connect the hydraulic pipes inside the unit to the delivery and return manifolds;
- Open the circuit breaker and disconnect the power supply;
- Disconnect the data and signal transmission cable;
- Remove the anchor plates joining adjacent units on the upper edges on the front and rear side;
- Remove the ground anchorage system.

Subsequently it is possible to lift and remove the unit by forklift truck.



Near the open switch, clearly indicate by means of a very visible sign not to close it due to maintenance activities being in progress.

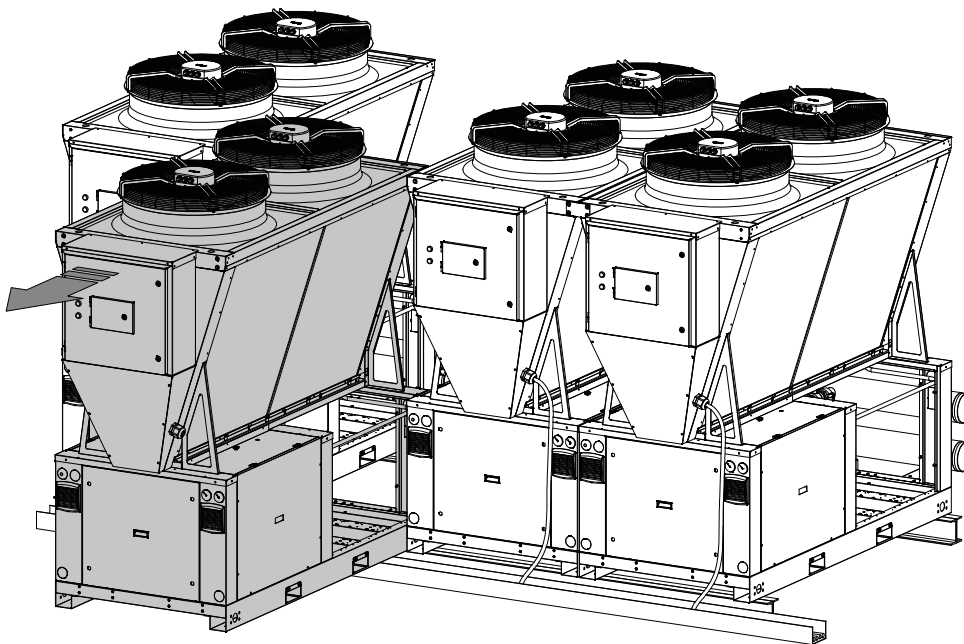

In order to lift and extract the module from the system, it is necessary to handle it from the front using forks at least as long as the module itself.

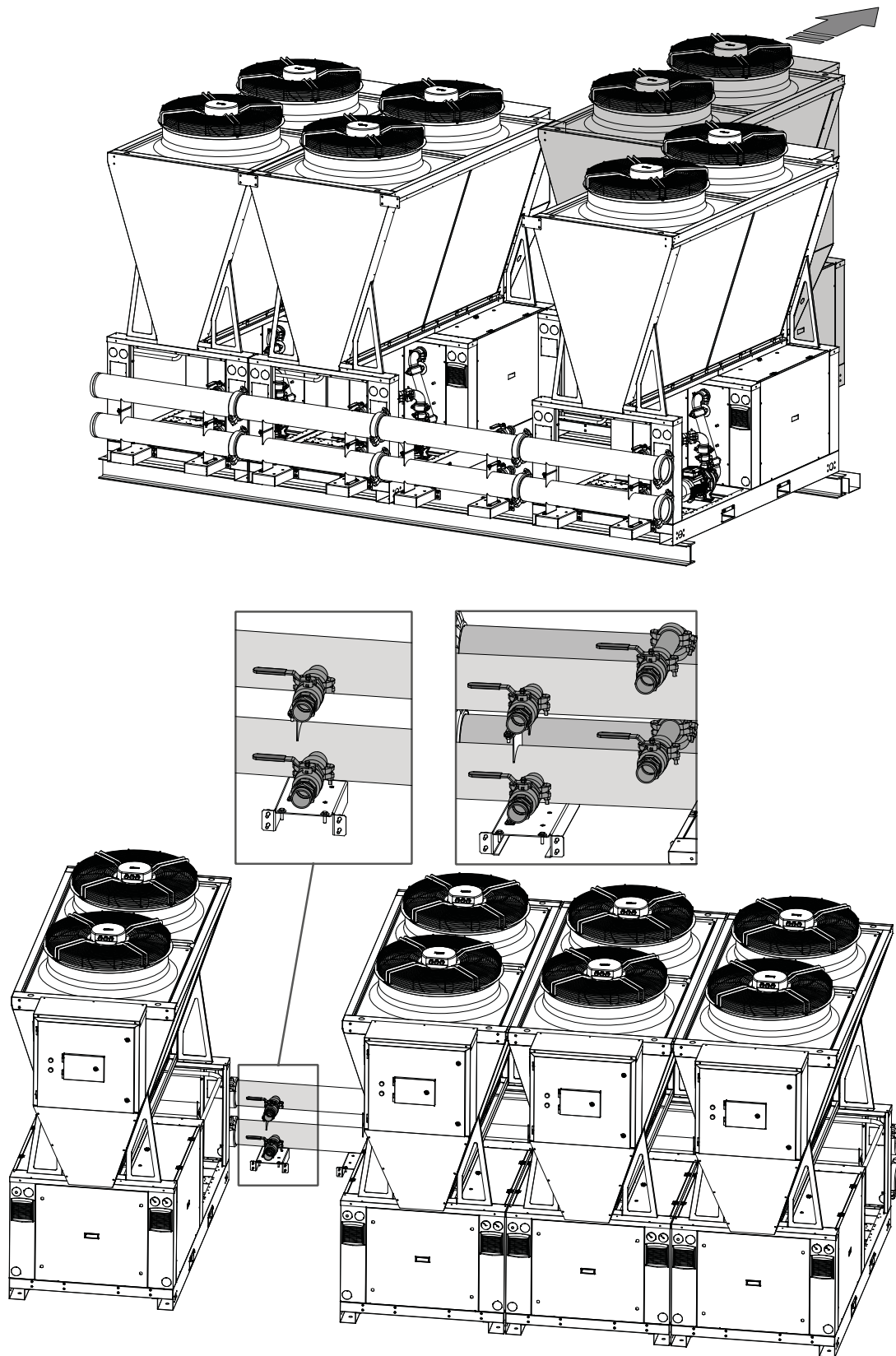

Make sure that the valves on the delivery and return manifolds are closed before removing the Victaulic joints present.

7.5 Periodical checks



The start-up operations should be performed in compliance with all requirements of the previous paragraphs.



All of the operations described in this chapter **MUST BE PERFORMED BY TRAINED PERSONNEL ONLY**. Before commencing service work on the unit ensure that the electric supply is disconnected. The top case and discharge line of compressor are usually at high temperature. Care must be taken when working in their surroundings. Aluminium coil fins are very sharp and can cause serious wounds. Care must be taken when working in their surroundings. After servicing, replace the cover panels, fixing them with locking screws.

7.5.1 Electrical system and control devices

Actions	Frequency						
	Daily	Monthly	Every 2 months	Every 6 months	Once a year	Every 5 years	If required
Check that the unit works properly and that there are no alarms	X						
Visually inspect the unit		X					
Check unit noise and vibration		X					
Check safety devices and interlocks				X			
Check the unit performances				X			
Check the absorbed current of the components (compressors, fans, pumps, etc.)				X			
Check the supply voltage of the unit				X			
Check the connection of cables to the pre-arranged clamps				X			
Check the integrity of the insulating coating of the electrical cables					X		
Check contactors conditions and functioning					X		
Check microprocessor and display functioning			X				
Check microprocessor set parameter values					X		
Eliminate any dust from electrical and electronic components				X			
Check probes and transducers functioning and calibration					X		
Check evaporator refrigerant level sensor functioning (if present)					X		
Check evaporator refrigerant level sensor calibration (if present)					X		
Check the calibration of the refrigerant leakage sensor					X		

7.5.2 Condensing coils fans and cooling circuit

Actions	Frequency						
	Daily	Monthly	Every 2 months	Every 6 months	Once a year	Every 5 years	If required
Visually inspect condensing coil		X					
Clean finned coils ⁽¹⁾				X			
Check the water flow and/or any leaks		X					
Check that the flow switch is working properly				X			
Clean the metallic filter on the water pipe ⁽³⁾				X			
Check fans noise and vibration		X					
Check fans supply voltage				X			
Check fans electrical connection					X		
Check proper operation and calibration of the fans speed regulation system					X		
Check 4 way valve proper operation (if present)					X		
Check 3 way valve proper operation (if present)					X		
Check presence of air the hydraulic circuit		X					
Check the color of the humidity display on the liquid line				X			
Check if there are any freon leaks ⁽²⁾							X



⁽¹⁾ If the unit is installed in strongly windy areas, near coasts or deserts or in areas subjects to wind and/or sand storms, or near airports, industries or in places with high levels of air pollution in general inspect the unit more frequently (every three months) to check the real condition of the surface protection. follow the instructions given in the paragraph "Cleaning the microchannel condensing coils".



⁽²⁾ In order to carry out operations on the refrigerant, it is necessary to observe the European Regulation 517_2014, "Obligations regarding the containment, use, recovery and destruction of fluorinated greenhouse gases used in stationary refrigeration, air conditioning and heat pump equipment".



⁽³⁾ It can be carried out with a higher frequency (also weekly) depending on the Δt .

7.5.3 Compressor

Actions	Frequency						
	Daily	Monthly	Every 2 months	Every 6 months	Once a year	Every 5 years	If required
Visually inspect compressors		X					
Check compressor noise and vibration		X					
Check compressors supply voltage				X			
Check the compressors electrical connections					X		
Check the oil level in the compressors using the oil level indicator light.				X			
Check that the crankcase heaters are powered and working properly.		X					
Check the conditions of the compressors electrical cables and their connection to their clamps				X			



Monthly and daily procedure can be directly done by the Owner. The other interventions must be done by qualified and suitably trained personnel.



Do not start any cleaning operation before disconnecting the unit from the electrical power supply, turning the main switch to OFF Position. Do not touch the equipment with barefoot or wet /damp parts of the body.



Any intervention on the cooling circuit must be done by qualified and suitable trained technicians, licensed in compliance with current local laws and regulation.

7.5.4 Check and calibration of the refrigerant leak detector

The maintenance (sight, operational and system one) of the detector must be done once a year to keep unchanged its safety and measurement performance and to grant the refrigerant detection alarm. The maintenance must be carefully done by skilled and qualified personnel. The system control, carried out by qualified personnel, must be done every 12 months at least and involves minimum the following operations:

- Functional check
- Failure relay check
- Alarm relay check
- Point 0 check

Control and calibration check with test gas; to carry on such a test, you can buy the calibration kit or send the detector to the Manufacturer for the calibration.

To carry on the test, you need to use the dedicated kit by the Manufacturer; In any case refer to the handbook of the detector supplied with the unit. The procedure indicated by the Manufacturer must be strictly followed. If the test is successfully completed, the detector can be installed and use once more.

If after the calibration is sensibility fall below the 55%, the detector must be replaced as suggested by the manufacturer.

7.5.6 End of seasons

If the unit is to be left out of commission for a long period, the hydraulic circuit should be drained down. This operation is compulsory if the ambient temperature is expected to drop below the freezing point of the fluid in the circuit (typical seasonal operation).

Before a new filling, the system must be washed.



After a long period of inactivity, before restarting the unit please keep the crankcase heaters energized for at least 12 hours.

7.5.7 Unit OFF

To stop the unit, press the ON/OFF key on the microprocessor, turning it on OFF position. If the unit will be OFF for more than 24 h turn the main switch to OFF position to cut the unit electrical power.

If any malfunction has occurred during the unit operation, solve it asap, in order to avoid that it will occur again at next operation.

7.6 Refrigerant circuit repair



Before any intervention with devices able to create sparks, heat, naked flames etc. totally empty and blow the circuit from any refrigerant.

For leak detection, the system should be charged with nitrogen using a gas bottle with a pressure reducing valve, until 15 bar pressure is reached. Any leakage is detected using a bubble leak finder. If bubbles appear discharge the nitrogen from the circuit before brazing using the proper alloys.



Never use oxygen instead of nitrogen: explosions may occur.

Site assembled refrigerant circuits must be assembled and maintained carefully, in order to prevent malfunctions.

Therefore:

- Avoid oil replenishment with products that are different from that specified and that are pre-loaded into the compressor.
- In the event of a gas leakage on machines using refrigerant R407C, even if it is only a partial leak, do not top up. The entire charge must be recovered, the leak repaired and a new refrigerant charge weighed in to the circuit.
- When replacing any part of the refrigerant circuit, do not leave it exposed for more than 15 minutes.
- It is important when replacing a compressor that the task be completed within the time specified above after removing the rubber sealing caps.
- When replacing the compressor following a burn out, it is advisable to wash the cooling system with appropriate products including a filter for acid.
- When under vacuum do not switch on the compressor.

8. DECOMMISSIONING

8.1 Disconnect the unit



All decommissioning operations must be performed by authorized personnel in accordance with the national legislation in force in the country where the unit is located.

- Avoid spills or leaks into the environment.
- Before disconnecting the machine for disposal please recover:
 - the refrigerant gas;
 - Glycol mixture in the hydraulic circuit;
 - the compressor lubricating oil.

Before decommissioning the machine can be stored outdoors, providing that it has the electrical box, refrigerant circuit and hydraulic circuit intact and closed.

8.2 Disposal, recovery and recycling

The frame and components, if unusable, should be taken apart and sorted by type, especially copper, aluminum and steel that are present in large quantities in the machine.

All materials must be recovered or disposed in accordance with national regulations.



The refrigerant circuit of the unit contains lubricant oil that binds the disposal mode of components .

8.3 RAEE Directive (only UE)



The crossed-out bin symbol on the label indicates that the product complies with regulations on waste electrical and electronic equipment.

The abandonment of the equipment in the environment or its illegal disposal is punishable by law.

This product is included in the application of Directive 2012/19/EU on the management of waste electrical and electronic equipment (WEEE).

The unit should not be treated with household waste as it is made of different materials that can be recycled at the appropriate facilities. Inform through the municipal authority about the location of the ecological platforms that can receive the product for disposal and its subsequent proper recycling.

The product is not potentially dangerous for human health and the environment, as it does not contain dangerous substances as per Directive 2011/65/EU (RoHS), but if abandoned in the environment it has a negative impact on the ecosystem.

Read the instructions carefully before using the unit for the first time. It is recommended not to use the product for any purpose other than that for which it was designed, as there is a risk of electric shock if used improperly.

9. DIMENSIONAL DRAWING



Dimensional drawings are to be considered indicative and not binding, therefore it is always necessary to request the definitive dimensional drawing before setting up the installation of the unit.

PAE 881 Kp
PAE 881 WA Kp

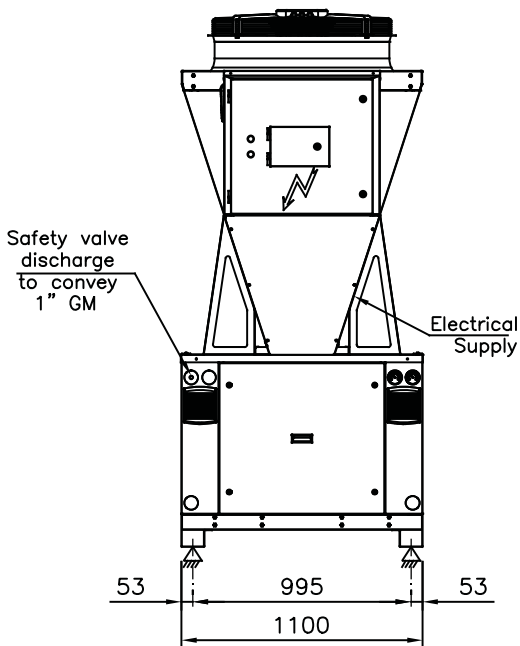
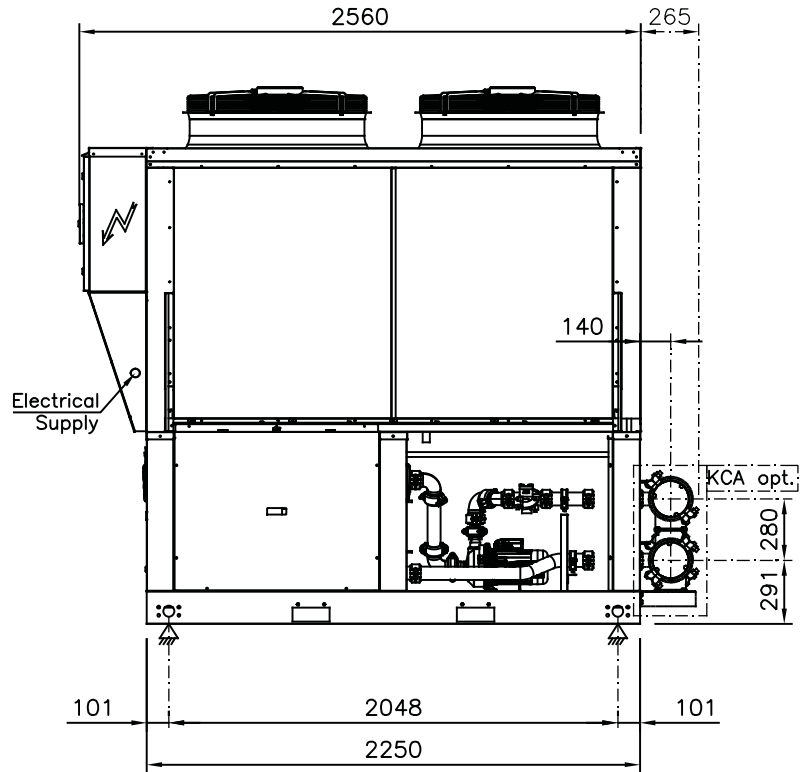
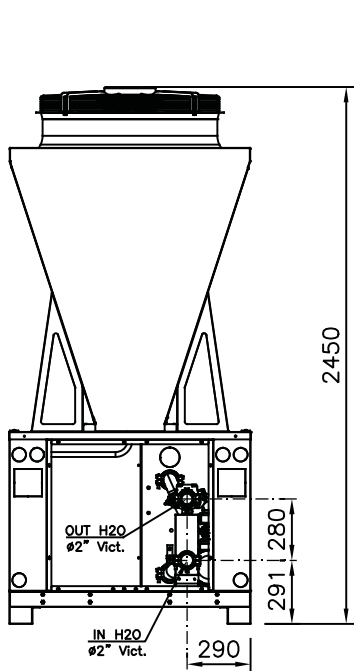

GPE 881 Kp

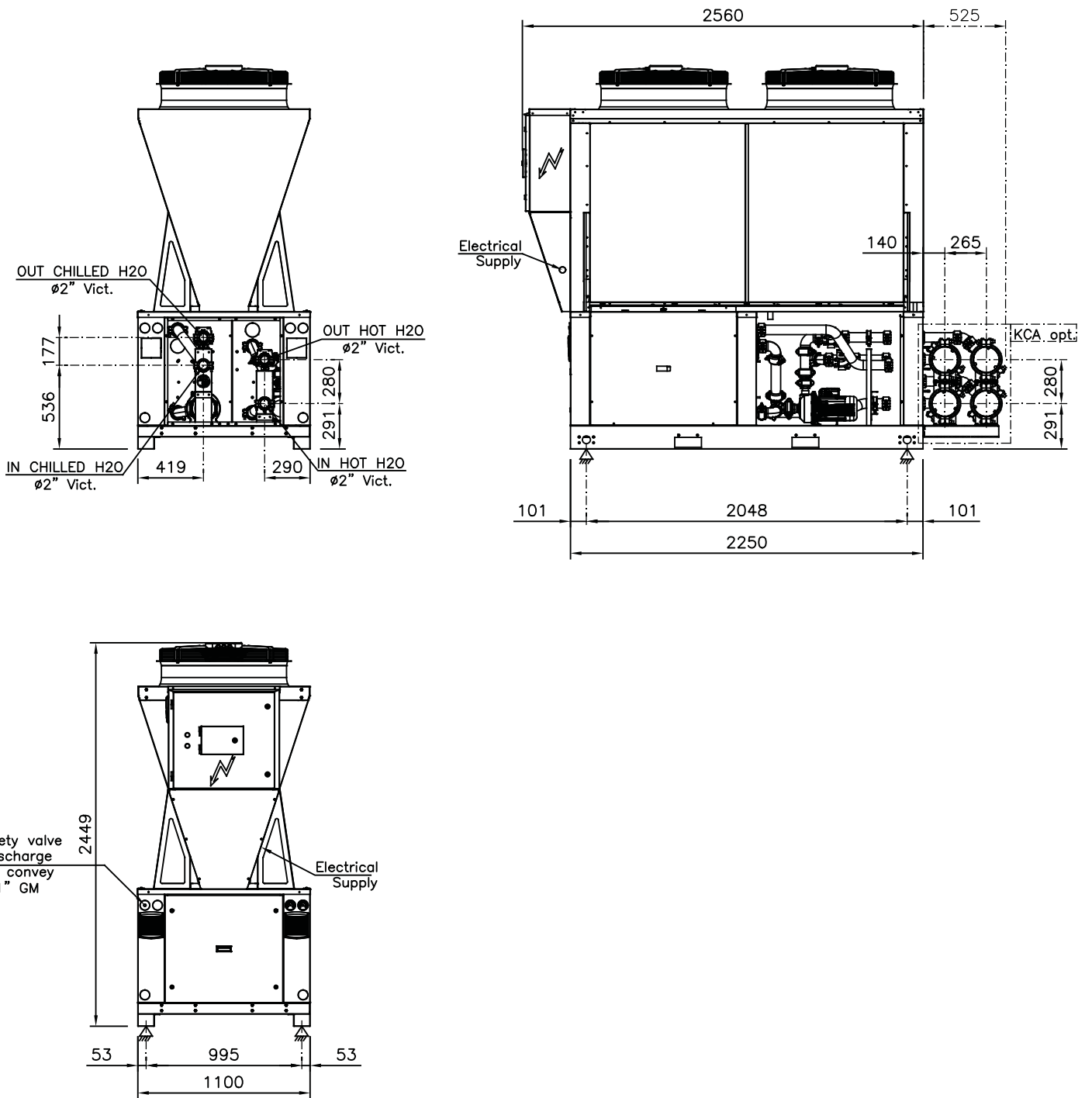



EMICON AC SPA

Via A. Volta, 49 ▪ cap 47014 ▪ Meldola (FC)
Tel. +39 0543 495611 ▪ Fax +39 0543 495612
emicon@emiconac.it ▪ www.emiconac.it

P.IVA e C.F. 03402390409 ▪ R.E.A. 299199

Technical data shown in this booklet are not binding.

The Company shall have the right to introduce at any time whatever modifications necessary to the improvement of the product.
The reference languages for the whole documentation are Italian and English. The other languages are to be considered only as guidelines.
