

SERVICE MANUAL



Indoor unit	Outdoor unit
ARXG24KMLA	AOYG24KBTB
ARXG30KMLA	AOYG30KBTB
ARXG36KMLA	AOYG36KBTB
ARXG45KMLA	AOYG45KBTB

CONTENTS

SPECIFICATIONS.....	1
DIMENSIONS.....	6
REFRIGERANT SYSTEM DIAGRAM... ..	18
INDOOR PCB CIRCUIT DIAGRAM	20
OUTDOOR PCB CIRCUIT DIAGRAM. . .	21
ERROR DETECTION	23
PARTS (INDOOR UNIT).....	25
PARTS (OUTDOOR UNIT).....	30
ACCESSORIES.....	46

Specifications (Indoor unit)

Type				Inverter heat pump					
Model name				ARXG24KMLA	ARXG30KMLA	ARXG36KMLA	ARXG45KMLA		
Power supply				230 V ~ 50 Hz					
Power supply intake				Outdoor unit					
Available voltage range				198—264 V					
Capacity	Cooling	Rated	kW	6.8	8.5	9.5	12.1		
			Btu/h	23,200	29,000	32,400	41,300		
		Min.—Max.	kW	0.9—8.0	2.8—10.0	2.8—11.2	4.0—13.0		
	Heating		Btu/h	3,100—27,300	9,600—34,100	9,600—38,200	13,600—44,400		
		Rated	kW	7.5	10.0	10.8	13.5		
			Btu/h	25,600	34,100	36,900	46,100		
	Min.—Max.	kW	0.9—9.1	2.7—11.2	2.7—12.7	4.2—15.2			
		Btu/h	3,100—31,000	9,200—38,200	9,200—43,300	14,300—51,900			
Input power	Cooling	Rated	kW	2.14	2.65	2.97	4.22		
		Max.		3.03	3.45	3.97	4.65		
	Heating	Rated		1.97	2.63	2.88	3.84		
		Max.		2.65	3.50	3.83	4.60		
Current	Cooling	Rated	A	9.4	11.7	13.1	18.6		
	Heating			8.7	11.7	12.8	16.9		
Power factor	Cooling		%	98.8	98.1	98.3	98.8		
	Heating			98.8	97.7	98.2	98.9		
EER	Cooling		kW/kW	3.18	3.21	3.20	2.87		
COP	Heating			3.80		3.75	3.52		
Moisture removal			L/h (pints/h)	2.5 (4.4)		3.0 (5.3)	4.0 (7.0)		
Maximum operating current *1		Cooling	A	13.6	22.6	22.6	28.5		
		Heating		13.6	22.6	22.6	28.5		
Fan	Airflow rate	Cooling	m ³ /h	HIGH	1,100	1,900	2,100		
				MED	910	1,620	1,750		
				LOW	750	1,270	1,350		
				QUIET	580	980	1,070		
		Heating		HIGH	1,100	2,100			
				MED	910	1,620	1,750		
				LOW	750	1,270	1,350		
				QUIET	580	980	1,070		
		Type × Q'ty			Sirocco × 2				
		Motor output			W	106	197		
Static pressure range			Pa	30 to 150					
Sound pressure level *2	Cooling	HIGH	dB (A)	31	39	42			
		MED		29	35	38			
		LOW		27	30	32			
		QUIET		25	26	28			
	Heating	HIGH		31	42	42			
		MED		29	35	38			
		LOW		27	30	32			
		QUIET		25	26	28			
Sound power level	Cooling	HIGH	dB (A)	60	65	68			
	Heating			62	69	70			
Heat exchanger type	Dimensions (H × W × D)		mm	294 × 1,000 × 39.9		294 × 1,000 × 53.2			
	Fin pitch			1.40					
	Rows × Stages		3 × 14			4 × 14			
	Pipe type		Copper						
	Fin type		Aluminum						
Enclosure		Material		Steel sheet					
		Color		—					
Dimensions (H × W × D)	Net	mm		270 × 1,135 × 700					
	Gross			300 × 1,320 × 790					
Weight	Net	kg		35	38	39			
	Gross			43	45	47			
Connection pipe	Size	Liquid	mm (in)	Ø6.35 (1/4)		Ø9.52 (3/8)			
		Gas		Ø12.70 (1/2)		Ø15.88 (5/8)			
Drain port	Method	mm		Flare					
	Material			Steel					
Operation range	Size	°C		Ø36 (I.D.), Ø38 (O.D.)					
				Cooling	18 to 32				
	Heating	°C		80 or less					
				16 to 30					
Remote control (Option)				Wired remote controller, Wireless remote controller, Mobile app*3 (FGLair™)					

NOTES:

- Specifications are based on the following conditions:
 - Cooling: Indoor temperature of 27 °CDB/19 °CWB, and outdoor temperature of 35 °CDB/24 °CWB.
 - Heating: Indoor temperature of 20 °CDB/15 °CWB, and outdoor temperature of 7 °CDB/6 °CWB.
 - Standard static pressure; 24 type: 35 Pa, 30 and 36 types: 47 Pa, 45 type: 60 Pa
 - Pipe length: 5 m, Height difference: 0 m. (Between outdoor unit and indoor unit.)
- Protective function might work when using it outside the operation range.
- *1: Maximum operating current is the total current of the indoor unit and the outdoor unit.
- *2: Sound pressure level:
 - Measured values in manufacturer's anechoic chamber.
 - Because of the surrounding sound environment, the sound levels measured in actual installation conditions might be higher than the specified values here.
- *3: Available on Google Play™ store or on App Store®. Optional WLAN adapter is also required. For details, refer to the setting manual.

Model name		ARXG24KMLA	ARXG30KMLA	ARXG36KMLA
Energy efficiency class	Cooling	A ⁺⁺	A ⁺⁺	A ⁺⁺
	Heating (Average)	A ⁺	A ⁺	A ⁺
P _{design}	Cooling	6.8 (35°C)	8.5 (35°C)	9.5 (35°C)
	Heating (Average)	6.0 (-10°C)	8.0 (-10°C)	8.7 (-10°C)
SEER	Cooling	6.20	6.23	6.10
SCOP	Heating (Average)	4.10	4.00	4.00
Annual energy consumption	QCE	384	477	545
	QHE (Average)	2,045	2,797	3,044

Specifications (Outdoor unit)

Type				Inverter heat pump
Model name				AOYG24KBTB
Power supply				230 V ~ 50 Hz
Power supply intake				Outdoor unit
Available voltage range				198—264 V
Starting current				9.4
Fan	Airflow rate	Cooling	m ³ /h	2,700
		Heating		2,700
	Type × Q'ty			Propeller × 1
	Motor output		W	49
Sound pressure level *1		Cooling	dB (A)	53
		Heating		54
Sound power level		Cooling	dB (A)	65
		Heating		66
Heat exchanger type	Dimensions (H × W × D)		mm	Main1: 672 × 881 × 18.2 Main2: 672 × 851 × 18.2
	Fin pitch			1.3
	Rows × Stages			2 × 32
	Pipe type			Copper tube
	Fin	Type (Material)		Aluminum
		Surface treatment		PC fin
Compressor	Type × Q'ty			DC Twin rotary × 1
	Motor output		W	1,060
Refrigerant	Type (Global warming potential)			R32 (675)
	Factory charge		g	1,250
Refrigerant oil	Type			RmM68AF
	Amount		cm ³	400
Enclosure	Material			Steel sheet
	Color			Beige Approximate color of Munsell 10YR 7.5/1.0
Dimensions (H × W × D)	Net		mm	716 × 820 × 315
	Gross			776 × 961 × 450
Weight	Net		kg	42
	Gross			46
Connection pipe	Size	Liquid	mm (in)	Ø6.35 (1/4)
		Gas		Ø12.70 (1/2)
	Method			Flare
	Pre-charge length		m	20
	Max. length			30
	Max. height difference			25
Operation range		Cooling	°C	-15 to 46
		Heating		-15 to 24
Drain hose	Material			PP
	Size		mm	Ø13.0 (I. D.), Ø16.0 to Ø16.8 (O. D.)
NOTES:				
<ul style="list-style-type: none"> • Specifications are based on the following conditions: <ul style="list-style-type: none"> – Cooling: Indoor temperature of 27 °CDB/19 °CWB, and outdoor temperature of 35 °CDB/24 °CWB. – Heating: Indoor temperature of 20 °CDB/15 °CWB, and outdoor temperature of 7 °CDB/6 °CWB. – Pipe length: 5 m, Height difference: 0 m. (Between outdoor unit and indoor unit.) • Protective function might work when using it outside the operation range. • *1: Sound pressure level <ul style="list-style-type: none"> – Measured values in manufacturer's anechoic chamber. – Because of the surrounding sound environment, the sound levels measured in actual installation conditions might be higher than the specified values here. 				

Type				Inverter heat pump	
Model name				AOYG30KBTB	AOYG36KBTB
Power supply				230 V ~ 50 Hz	
Power supply intake				Outdoor unit	
Available voltage range				198—264 V	
Starting current				11.7	13.1
Fan	Airflow rate	Cooling	m ³ /h	3,750	
		Heating		3,750	
	Type × Q'ty			Propeller × 1	
	Motor output			100	
Sound pressure level *1		Cooling	dB (A)	53	55
		Heating		55	55
Sound power level		Cooling	dB (A)	68	70
		Heating		69	70
Heat exchanger type	Dimensions (H × W × D)		mm	Main1: 756 × 905 × 18.2 Main2: 756 × 905 × 18.2	
	Fin pitch			1.45	
	Rows × Stages			1 × 36	
	Pipe type			Copper	
	Fin	Type (Material)		Aluminum	
		Surface treatment		Blue fin	
Compressor	Type × Q'ty		DC Twin rotary × 1		
	Motor output		1,500		
Refrigerant	Type (Global warming potential)		R32 (675)		
	Factory charge		g		
Refrigerant oil	Type		FW68D		
	Amount		cm ³		
Enclosure	Material			Steel sheet	
	Color			Beige Approximate color of Munsell 10YR 7.5/1.0	
Dimensions (H × W × D)	Net		mm	788 × 940 × 320	
	Gross			966 × 1,027 × 445	
Weight	Net		kg	52	
	Gross			60	
Connection pipe	Size	Liquid	mm (in)	Ø9.52 (3/8)	
		Gas		Ø15.88 (5/8)	
	Method			Flare	
	Pre-charge length			30	
	Max. length			50	
	Max. height difference			30	
Operation range		Cooling	°C	-15 to 46	
		Heating		-15 to 24	
Drain hose	Material			LDPE	
	Size			Ø13.0 (I. D.), Ø16.0 to Ø16.8 (O. D.)	

NOTES:

- Specifications are based on the following conditions:
 - Cooling: Indoor temperature of 27 °CDB/19 °CWB, and outdoor temperature of 35 °CDB/24 °CWB.
 - Heating: Indoor temperature of 20 °CDB/15 °CWB, and outdoor temperature of 7 °CDB/6 °CWB.
 - Pipe length: 5 m, Height difference: 0 m. (Between outdoor unit and indoor unit.)
- Protective function might work when using it outside the operation range.
- *1: Sound pressure level
 - Measured values in manufacturer's anechoic chamber.
 - Because of the surrounding sound environment, the sound levels measured in actual installation conditions might be higher than the specified values here.

Type				Inverter heat pump
Model name				AOYG45KBTB
Power supply				230 V ~ 50 Hz
Power supply intake				Outdoor unit
Available voltage range				198—264 V
Starting current				18.6
Fan	Airflow rate	Cooling	m ³ /h	4,450
		Heating		4,450
	Type × Q'ty			Propeller × 1
	Motor output		W	120
Sound pressure level *1		Cooling	dB (A)	57
		Heating		57
Sound power level		Cooling	dB (A)	71
		Heating		71
Heat exchanger type	Dimensions (H × W × D)		mm	Main1: 966 × 905 × 18.2 Main2: 966 × 905 × 18.2 Sub: 966 × 543 × 18.2
	Fin pitch			1.45
	Rows × Stages			1 × 46
	Pipe type			Copper
	Fin	Type (Material)		Aluminum
		Surface treatment		Blue fin
Compressor	Type × Q'ty			DC Twin rotary × 1
	Motor output		W	2,180
Refrigerant	Type (Global warming potential)			R32 (675)
	Factory charge		g	2,700
Refrigerant oil	Type			RmM68AF
	Amount		cm ³	800
Enclosure	Material			Steel sheet
	Color			Beige Approximate color of Munsell 10YR 7.5/1.0
Dimensions (H × W × D)	Net		mm	998 × 940 × 320
	Gross			1,176 × 1,027 × 445
Weight	Net		kg	67
	Gross			75
Connection pipe	Size	Liquid	mm (in)	Ø9.52 (3/8)
		Gas		Ø15.88 (5/8)
	Method			Flare
	Pre-charge length		m	30
	Max. length			50
	Max. height difference			30
Operation range		Cooling	°C	-15 to 46
		Heating		-15 to 24
Drain hose	Material			LDPE
	Size		mm	Ø13.0 (I. D.), Ø16.0 to Ø16.8 (O. D.)

NOTES:

- Specifications are based on the following conditions:
 - Cooling: Indoor temperature of 27 °CDB/19 °CWB, and outdoor temperature of 35 °CDB/24 °CWB.
 - Heating: Indoor temperature of 20 °CDB/15 °CWB, and outdoor temperature of 7 °CDB/6 °CWB.
 - Pipe length: 5 m, Height difference: 0 m. (Between outdoor unit and indoor unit.)
- Protective function might work when using it outside the operation range.
- *1: Sound pressure level
 - Measured values in manufacturer's anechoic chamber.
 - Because of the surrounding sound environment, the sound levels measured in actual installation conditions might be higher than the specified values here.

Dimensions (Indoor unit)

Models: ARXG24KMLA, ARXG30KMLA, ARXG36KMLA, and ARXG45KMLA

Unit: mm

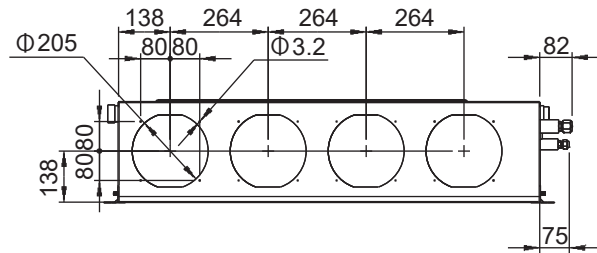

Front view

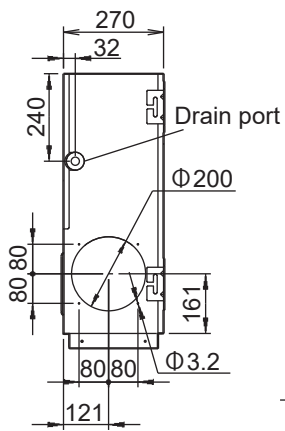

Side view (L)

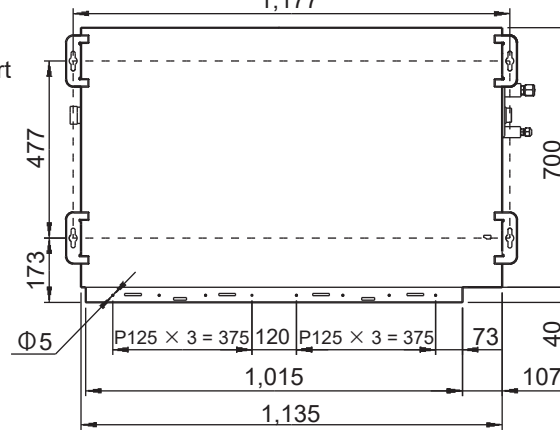

Top view

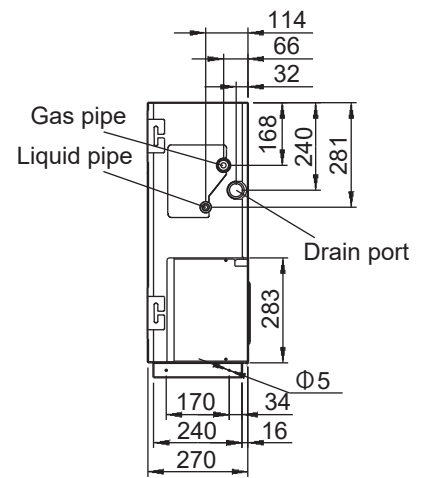

Side view (R)

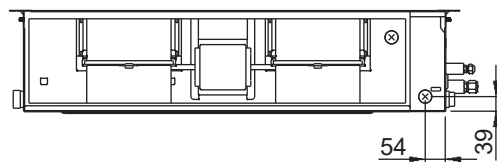

Rear view

Installation space requirement

Provide sufficient installation space for product safety.

Models: ARXG24KMLA, ARXG30KMLA, ARXG36KMLA, and ARXG45KMLA

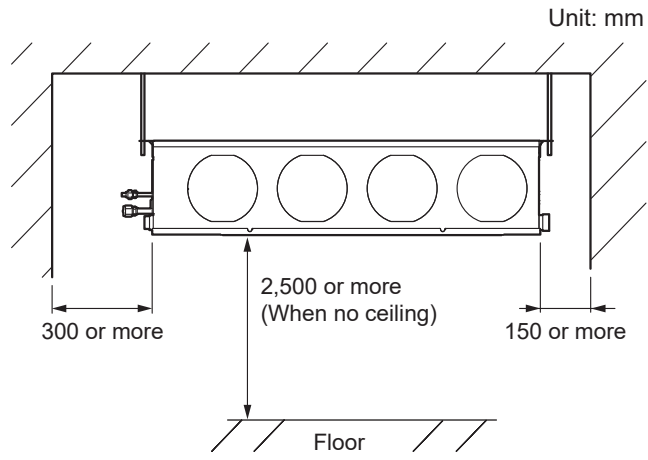

Maintenance space requirement

For future maintenance and service access, provide sufficient maintenance space.

NOTE: Do not place any wiring or illumination in the maintenance space, as they will impede service.

Models: ARXG24KMLA, ARXG30KMLA, ARXG36KMLA, and ARXG45KMLA

Unit: mm

- Provide a service access for maintenance purposes.

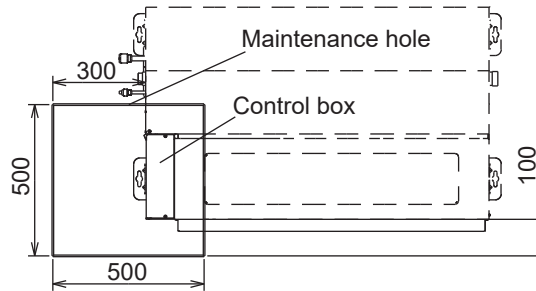

- The service access necessary for fan units and filter maintenance.

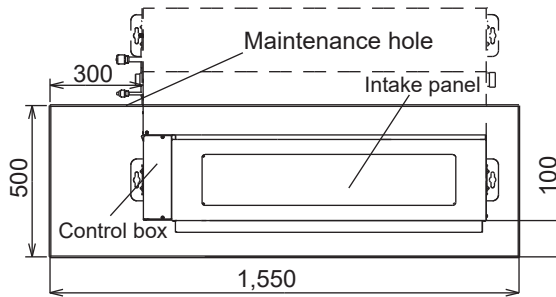

- When using a square duct

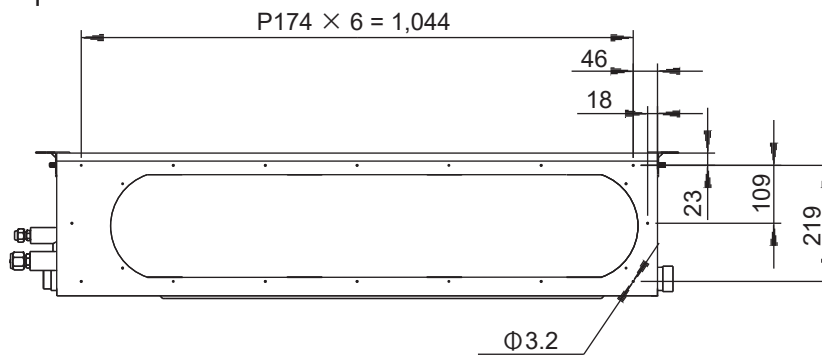

- Bottom air intake hole

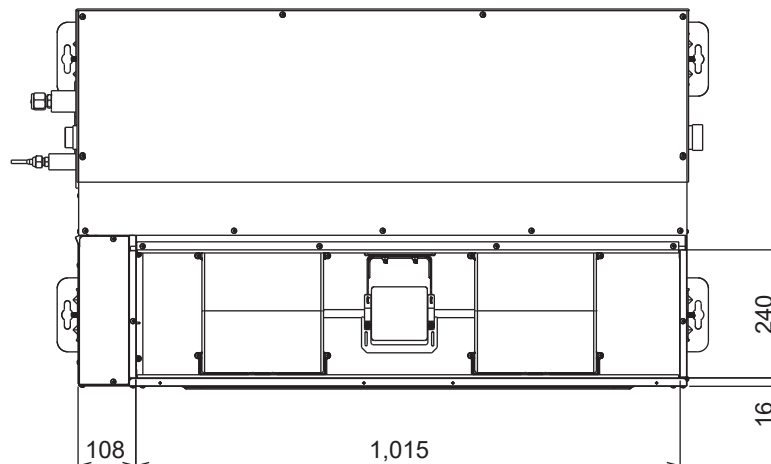

Dimensions (Outdoor unit)

Model: AOYG24KBTB

Unit: mm

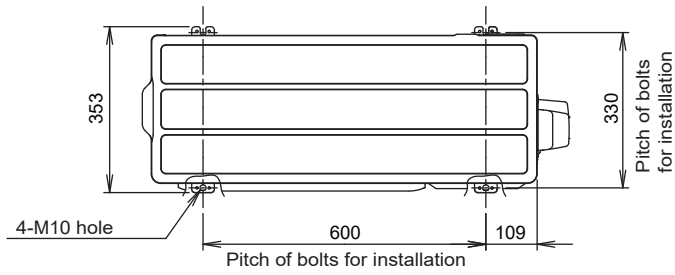

Top view

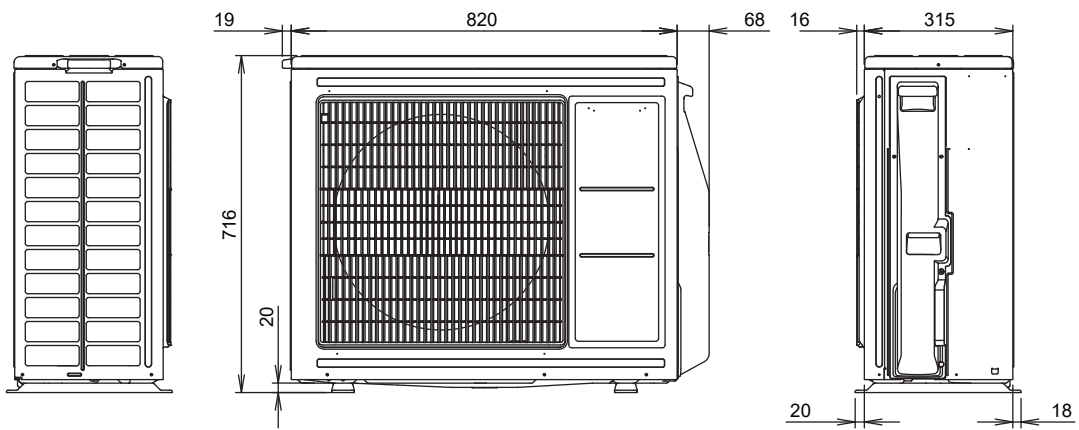

Side view

Front view

Side view

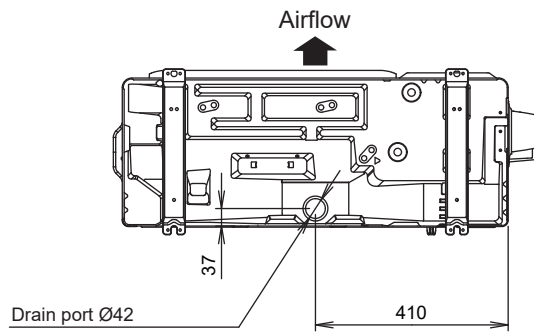

Drain port Ø42

Bottom view

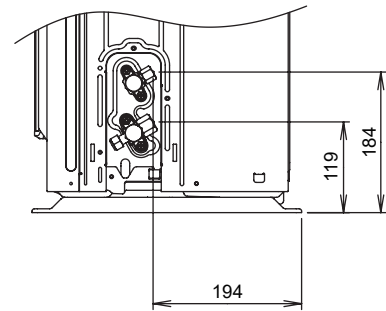

Side view (Valve part)

Models: AOYG30KBTB and AOYG36KBTB

Unit: mm

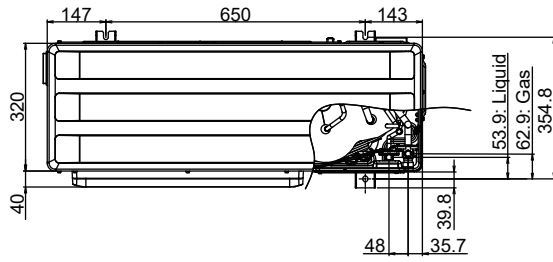

Top view

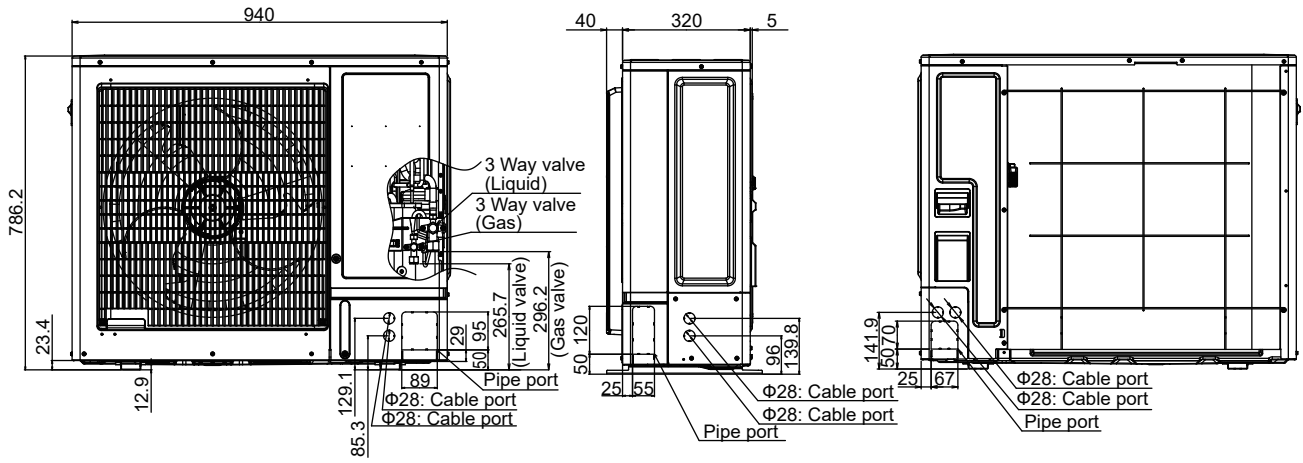

Front view

Side view

Rear view

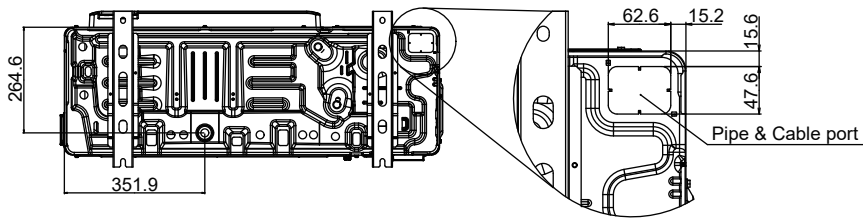

Bottom view

Model: AOYG45KBTB

Unit: mm

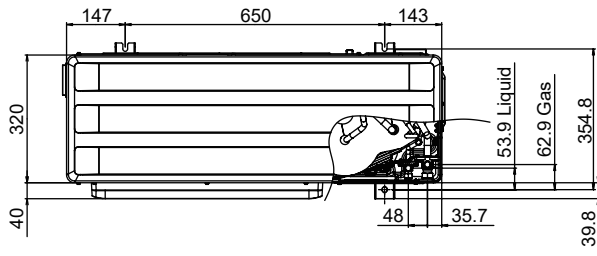

Top view

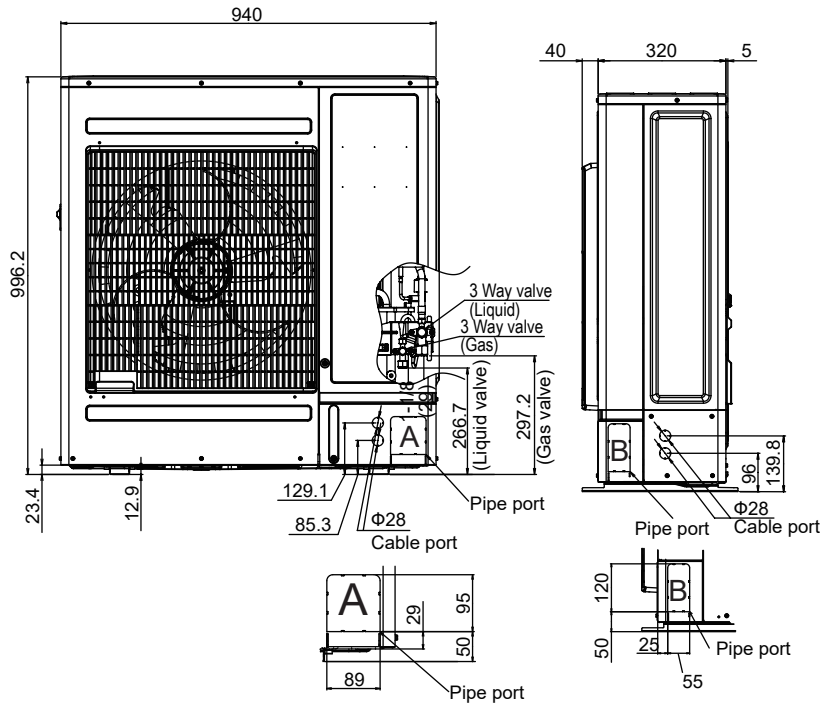

Front view

Side view

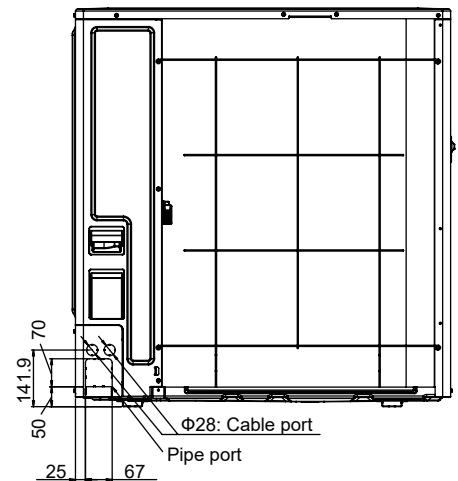

Rear view

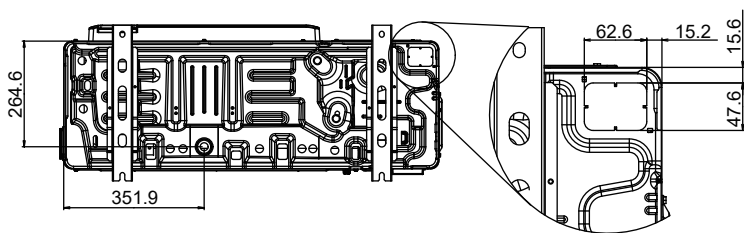

Bottom view

Pipe & Cable port

Installation space

Model: AOYG24KBTB

Space requirement

Provide sufficient installation space for product safety.

⚠ CAUTION

Keep the space shown in the installation examples.

If the installation is not performed accordingly, it could cause a short circuit and result in a lack of operating performance.

Single outdoor unit installation

- When the upper space is open:

Unit: mm

Obstacles at rear only

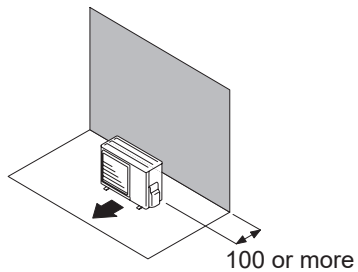

Obstacles at rear and sides

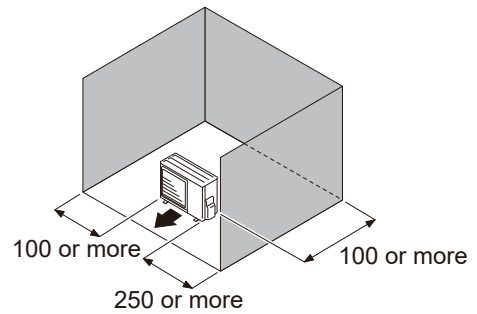

Obstacles at front

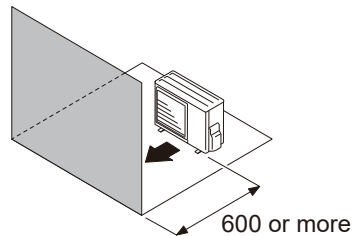

Obstacles at front and rear

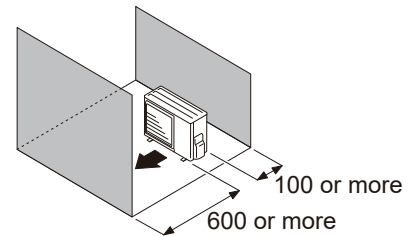

- When there is an obstruction in the upper space:

Unit: mm

Obstacles at rear and above

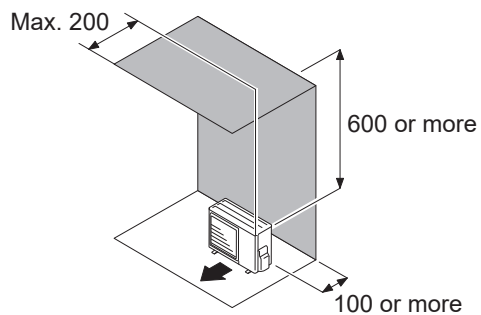

Obstacles at rear, sides, and above

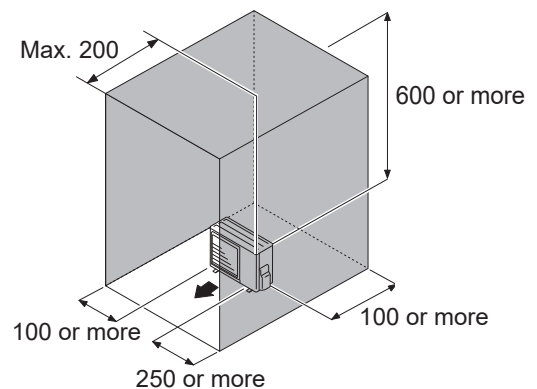

Multiple outdoor unit installation

- Provide at least 250 mm of space between the outdoor units if multiple units are installed.
 - When routing the piping from the side of an outdoor unit, provide space for piping.
 - No more than 3 units must be installed side by side.
When 3 units or more are arranged in a line, provide the space as shown in the following example **“When an obstruction in the upper space:”**.
- **When the upper space is open:**

Unit: mm

Obstacles at rear only

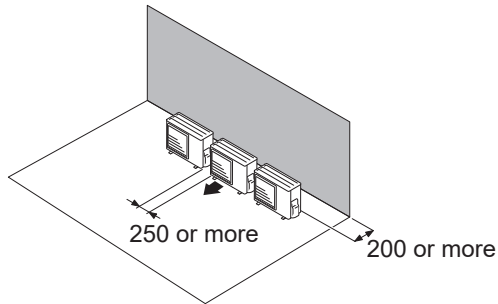

Obstacles at front only

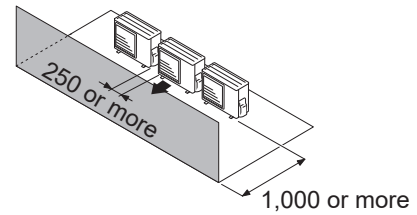

Obstacles at front and rear

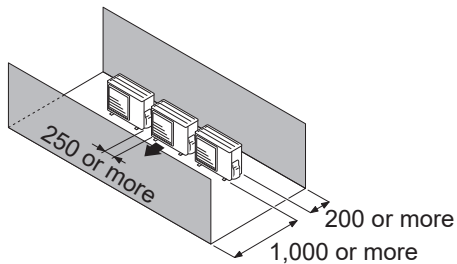

- **When an obstruction in the upper space:**

Unit: mm

Obstacles at rear and above.

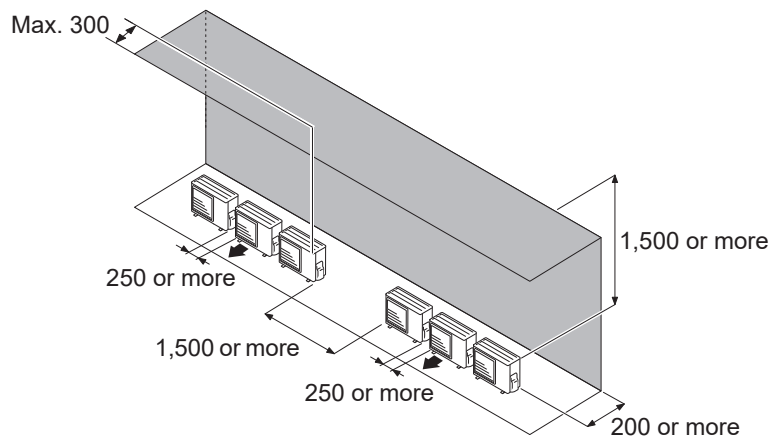

Outdoor units installation in multi-row

Unit: mm

Single parallel unit arrangement

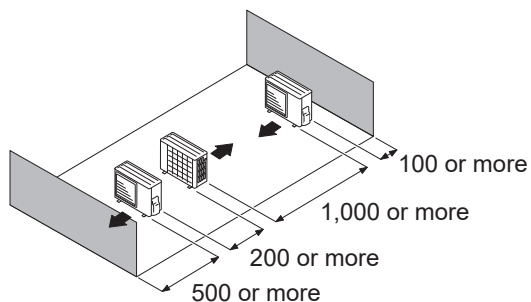

Multiple parallel unit arrangement

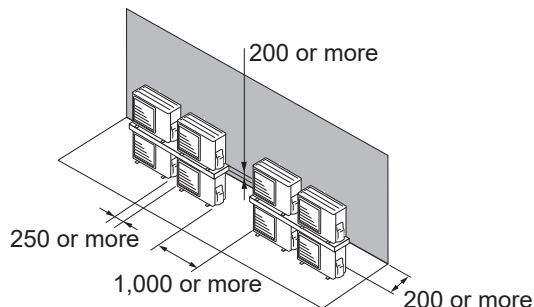
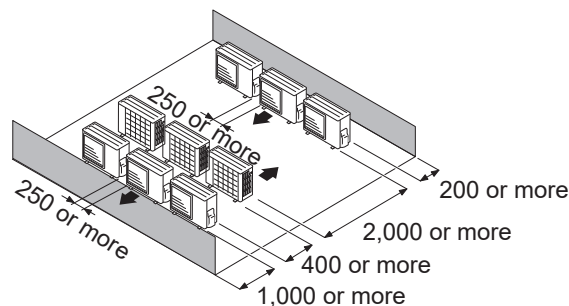

NOTES:

- If the space is larger than stated above, the condition will be the same as when there is no obstacle.
- When installing the outdoor unit, be sure to open the front and left side to obtain better operation efficiency.

⚠ CAUTION

- Do not install the outdoor unit in two-stage where the drain water could freeze. Otherwise the drainage from the upper unit may form ice and cause a malfunction of the lower unit.
- When the outdoor temperature is 0 °C or less, do not use the accessory drain pipe and drain cap. If the drain pipe and drain cap are used, the drain water in the pipe may freeze in extremely cold climate. (For reverse cycle model only.)
- In area with heavy snowfall, if the inlet and outlet of the outdoor unit is blocked with snow, it might become difficult to get warm, and it is likely to cause product malfunction. Construct a canopy and a pedestal, or place the unit on a high stand that is locally installed.

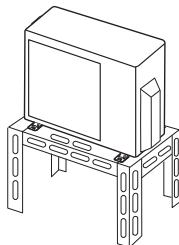

Models: AOYG30KBTB, AOYG36KBTB, and AOYG45KBTB

Space requirement

Provide sufficient installation space for product safety.

Single outdoor unit installation

- When the upper space is open:

Unit: mm

When there are obstacles at the rear only.

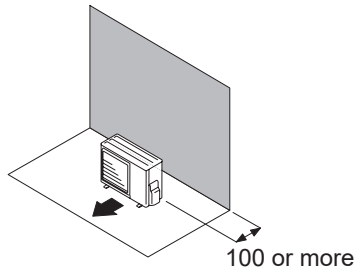

When there are obstacles at the rear and sides.

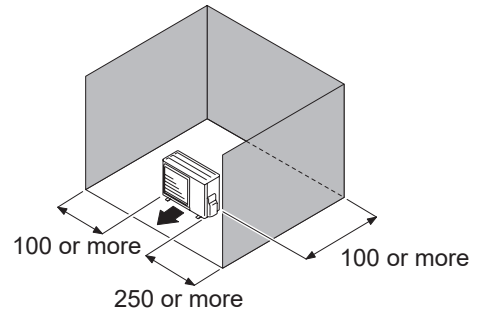

When there are obstacles at the front only.

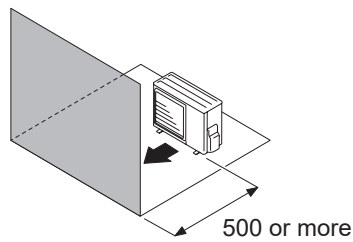

When there are obstacles at the front and rear.

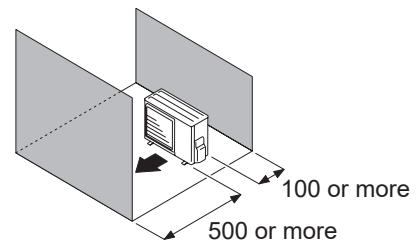

- When there is an obstruction in the upper space:

Unit: mm

When there are obstacles at the rear and above.

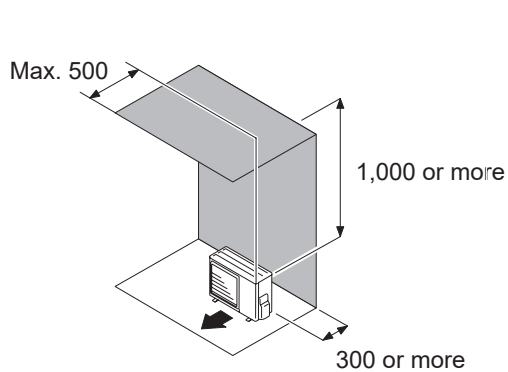

When there are obstacles at the rear, sides, and above.

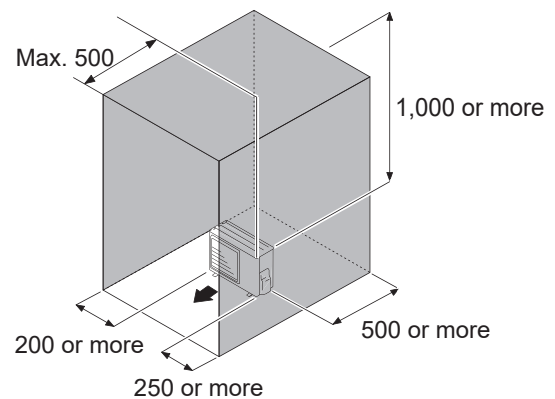

Multiple outdoor unit installation

- When the upper space is open:

Unit: mm

When there are obstacles at the rear only.

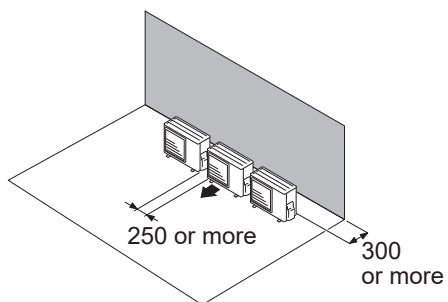

When there are obstacles at the front only.

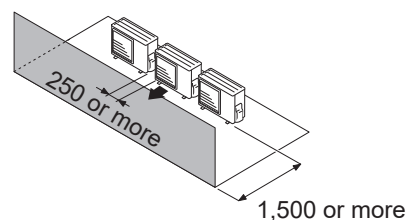

When there are obstacles at the front and rear.

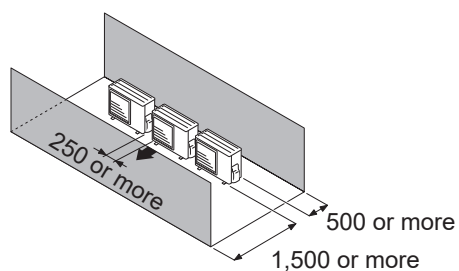

- When there is an obstruction in the upper space:

Unit: mm

When there are obstacles at the rear and above.

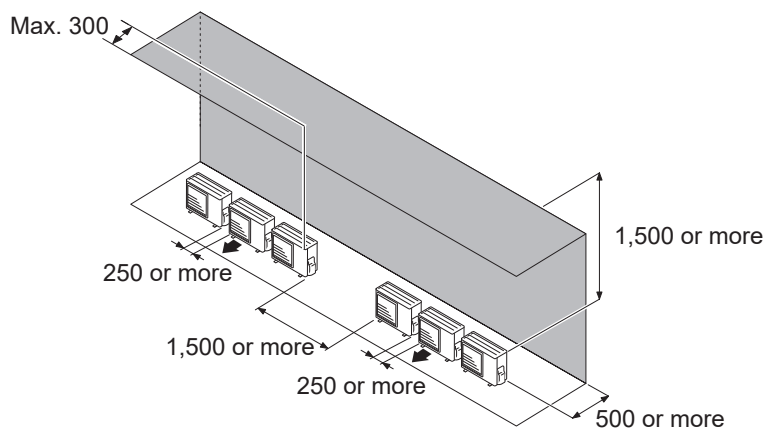

Outdoor unit installation in multi-row

Unit: mm

Single parallel unit arrangement

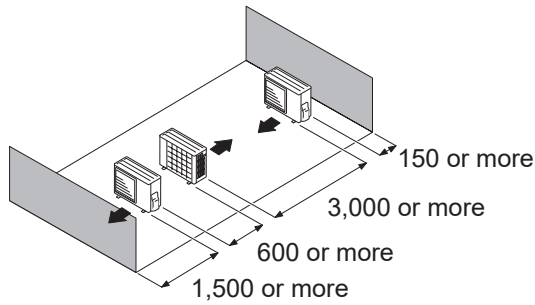

Multiple parallel unit arrangement

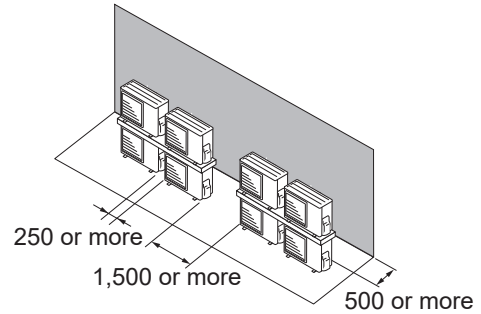
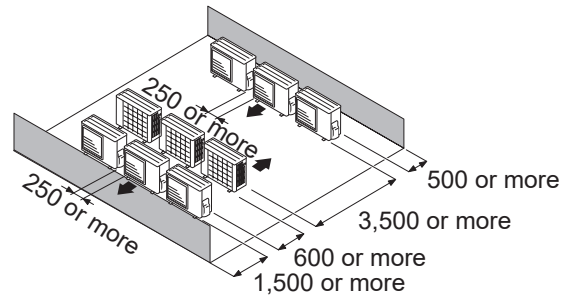

NOTES:

- If the space is larger than stated above, the condition will be the same as when there is no obstacle.
- Height above the floor level should be 50 mm or more.
- When installing the outdoor unit, be sure to open the front and left side to obtain better operation efficiency.

⚠ CAUTION

- Do not install the outdoor unit in two-stage where the drain water could freeze. Otherwise the drainage from the upper unit may form ice and cause a malfunction of the lower unit.
- When the outdoor temperature is 0 °C or less, do not use the accessory drain pipe and drain cap. If the drain pipe and drain cap are used, the drain water in the pipe may freeze in extremely cold climate. (For reverse cycle model only.)
- In area with heavy snowfall, if the inlet and outlet of the outdoor unit is blocked with snow, it might become difficult to get warm, and it is likely to cause product malfunction. Construct a canopy and a pedestal, or place the unit on a high stand that is locally installed.

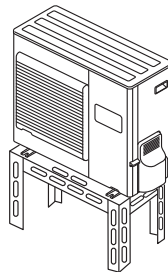

Refrigerant circuit

Models: AOYG24KBTB and AOYG30KBTB

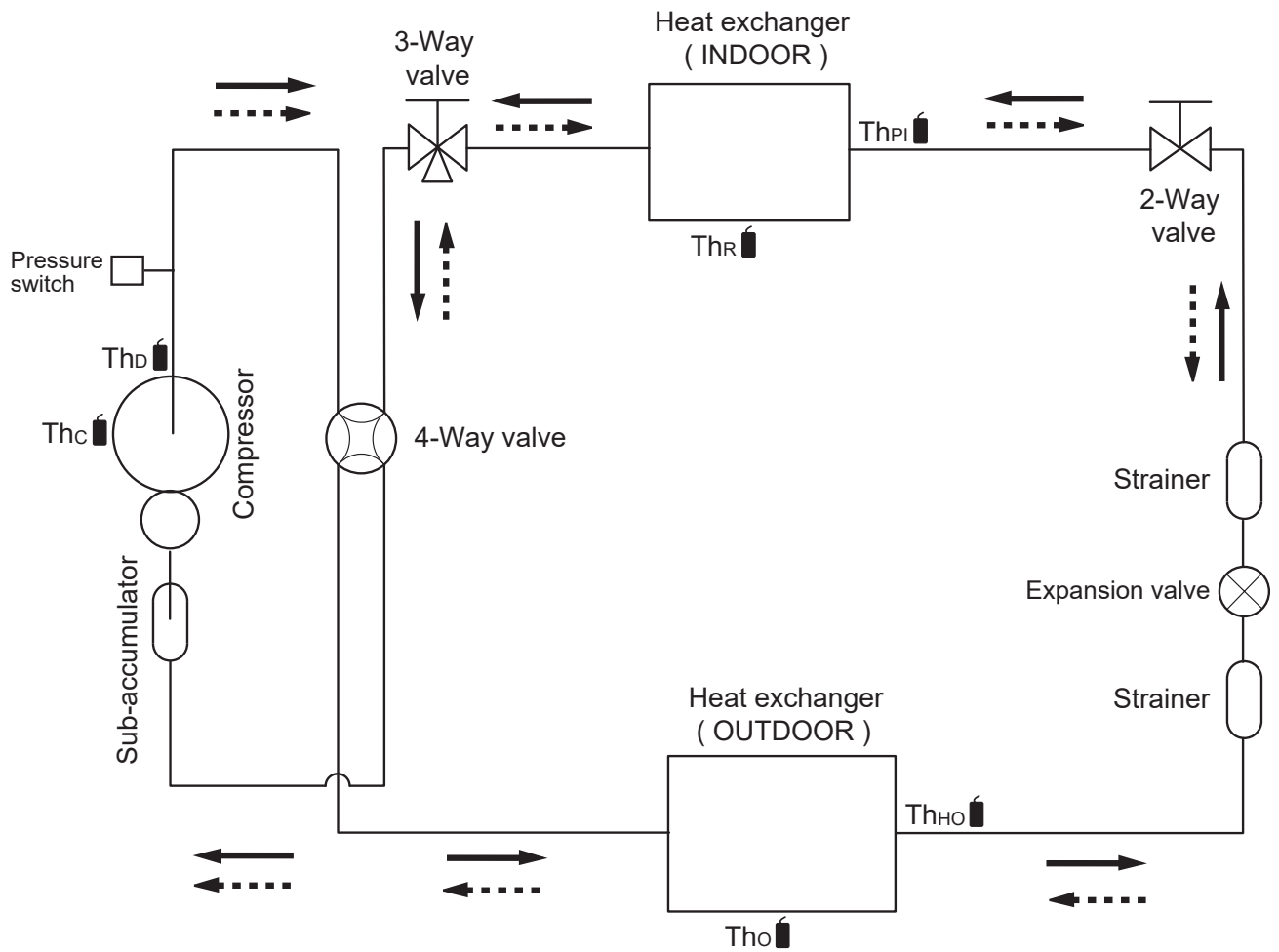

—→ : Cooling
 - - - -> : Heating

- Th_c : Thermistor (Compressor temperature)
- Th_D : Thermistor (Discharge temperature)
- Th_o : Thermistor (Outdoor temperature)
- Th_{HO} : Thermistor (Heat Exchanger Out temperature)
- Th_R : Thermistor (Room temperature)
- Th_{PI} : Thermistor (Pipe temperature)

Models:AOYG36KBTB and AOYG45KBTB

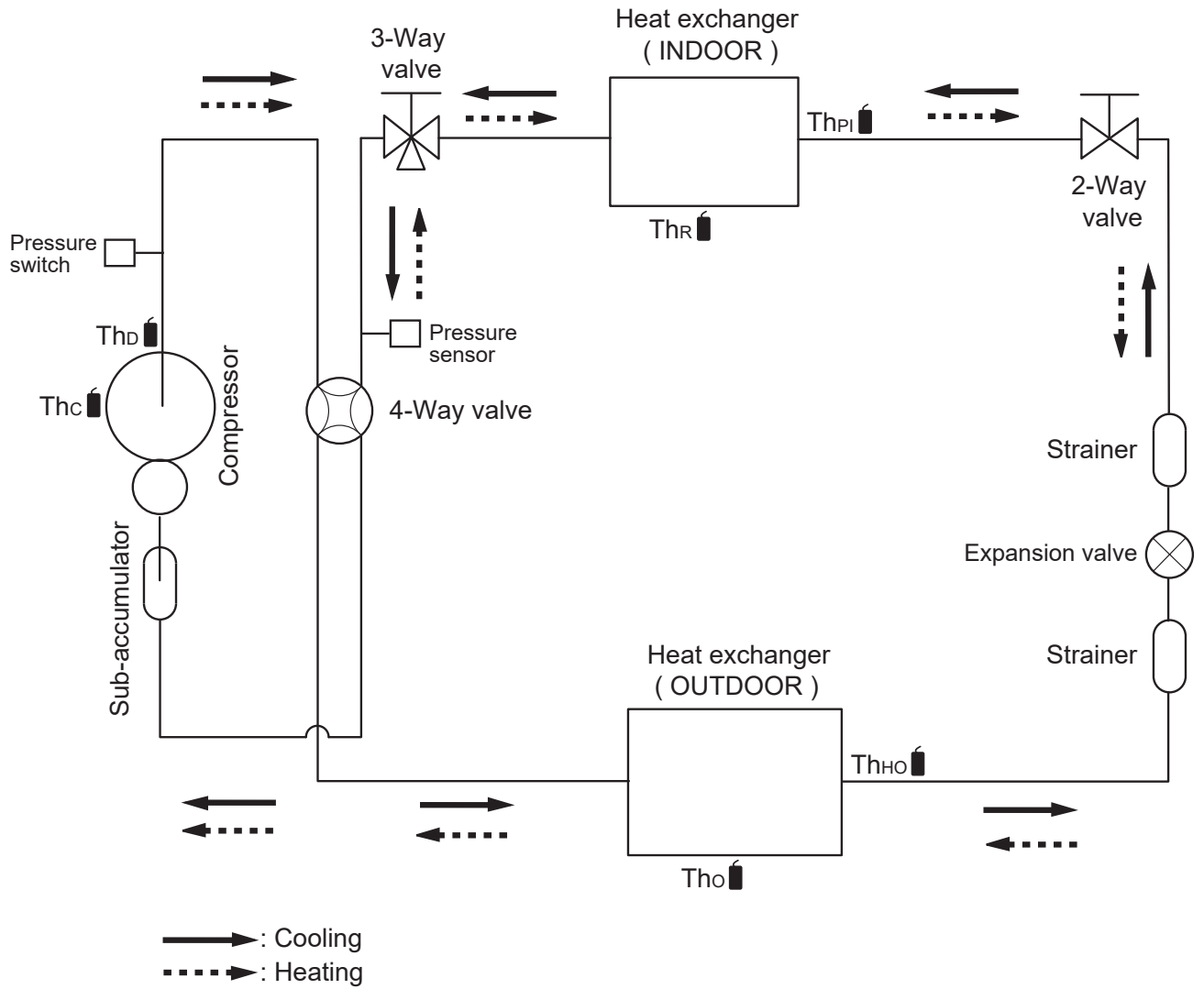

- Th_c : Thermistor (Compressor temperature)
- Th_d : Thermistor (Discharge temperature)
- Th_o : Thermistor (Outdoor temperature)
- Th_{HO} : Thermistor (Heat Exchanger Out temperature)
- Th_R : Thermistor (Room temperature)
- Th_{PI} : Thermistor (Pipe temperature)

INDOOR PRINTED CIRCUIT BOARD CIRCUIT DIAGRAM

Models : ARXG24KMLA
ARXG30KMLA
ARXG36KMLA
ARXG45KMLA

CONTROL UNIT
ARXG24KMLA : EZ-0182EHSE
ARXG30KMLA : EZ-0182FHSE
ARXG36KMLA : EZ-0182GHSE
ARXG45KMLA : EZ-0182HHSE

CN8 Thermistor Characteristics.

Thermistor	Temperature	(0°C)	(20°C)	(30°C)
Thermistor (Room temp.)		33.6 k Ω	12.5 k Ω	8.0 k Ω
		1.1 V	2.2 V	2.8 V

CN6 Thermistor Characteristics.

Thermistor	Temperature	(0°C)	(20°C)	(30°C)
Thermistor (Pipe temp.)		168.6 k Ω	62.5 k Ω	40.0 k Ω
		1.1 V	2.2 V	2.8 V

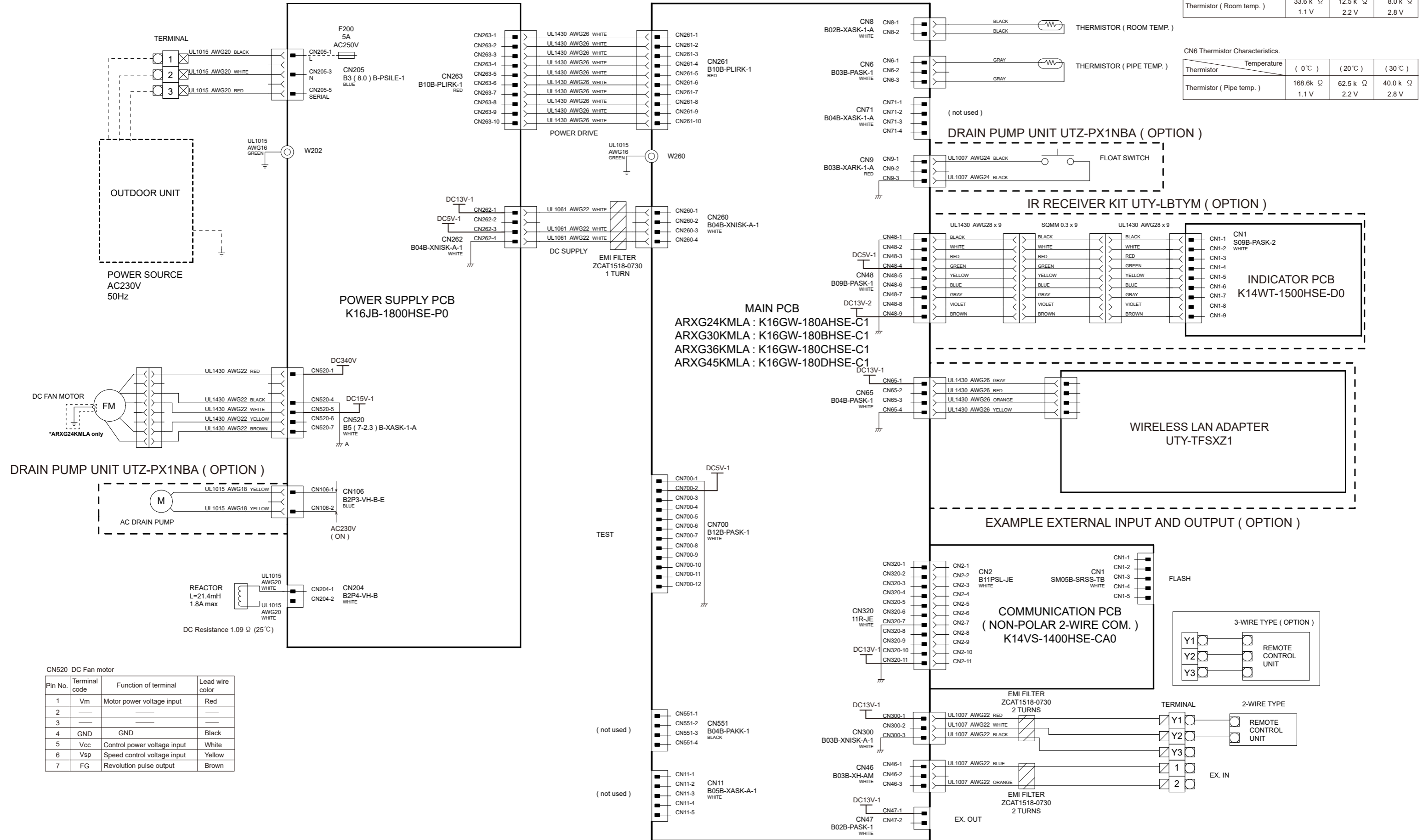

CN520 DC Fan motor

Pin No.	Terminal code	Function of terminal	Lead wire color
1	Vm	Motor power voltage input	Red
2	---	---	---
3	---	---	---
4	GND	GND	Black
5	Vcc	Control power voltage input	White
6	Vsp	Speed control voltage input	Yellow
7	FG	Revolution pulse output	Brown

OUTDOOR PRINTED CIRCUIT BOARD CIRCUIT DIAGRAM

Model : AOYG24KBTB

INVERTER ASSEMBLY
EZ-01801HUE

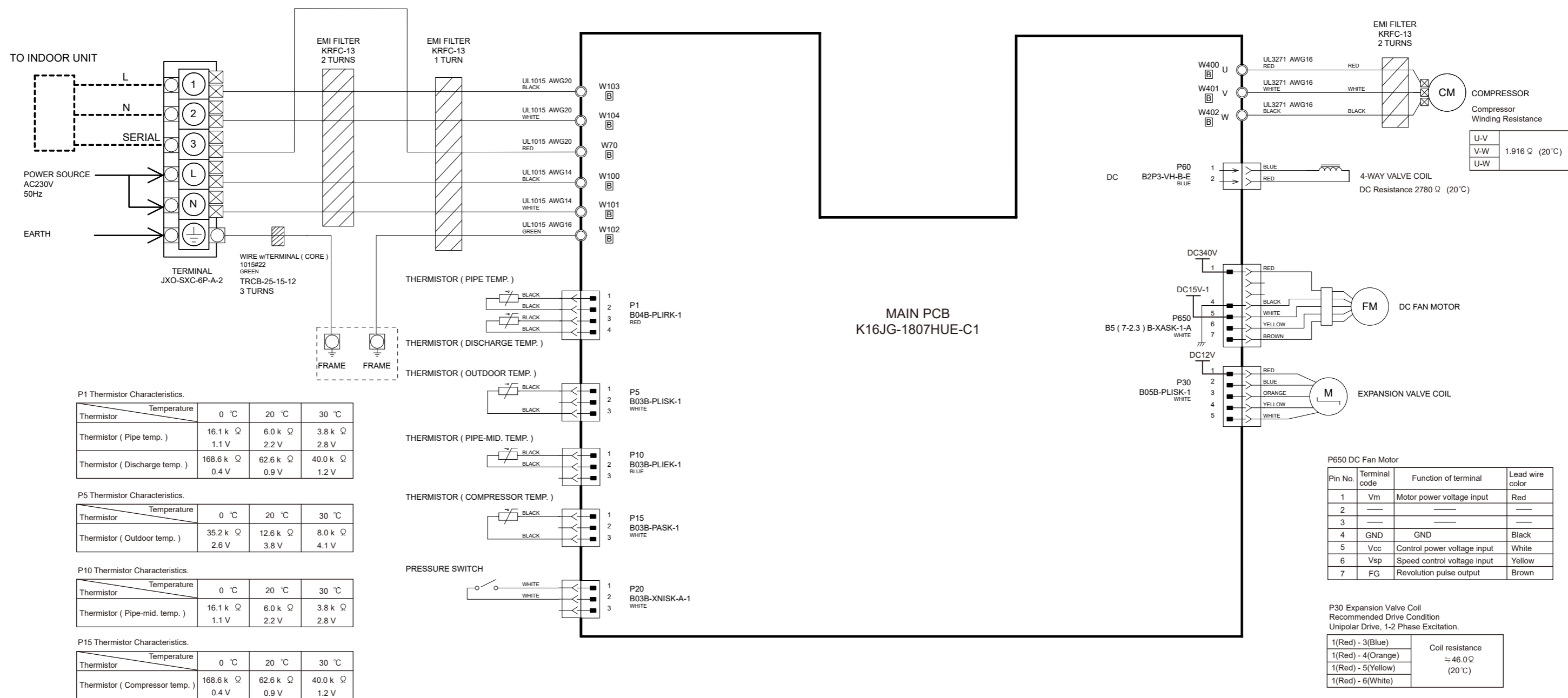

P1 Thermistor Characteristics.

Thermistor	Temperature	0 °C	20 °C	30 °C
Thermistor (Pipe temp.)		16.1 k Ω 1.1 V	6.0 k Ω 2.2 V	3.8 k Ω 2.8 V
Thermistor (Discharge temp.)		168.6 k Ω 0.4 V	62.6 k Ω 0.9 V	40.0 k Ω 1.2 V

P5 Thermistor Characteristics.

Thermistor	Temperature	0 °C	20 °C	30 °C
Thermistor (Outdoor temp.)		35.2 k Ω 2.6 V	12.6 k Ω 3.8 V	8.0 k Ω 4.1 V

P10 Thermistor Characteristics.

Thermistor	Temperature	0 °C	20 °C	30 °C
Thermistor (Pipe-mid. temp.)		16.1 k Ω 1.1 V	6.0 k Ω 2.2 V	3.8 k Ω 2.8 V

P15 Thermistor Characteristics.

Thermistor	Temperature	0 °C	20 °C	30 °C
Thermistor (Compressor temp.)		168.6 k Ω 0.4 V	62.6 k Ω 0.9 V	40.0 k Ω 1.2 V

P650 DC Fan Motor

Pin No.	Terminal code	Function of terminal	Lead wire color
1	Vm	Motor power voltage input	Red
2	—	—	—
3	—	—	—
4	GND	GND	Black
5	Vcc	Control power voltage input	White
6	Vsp	Speed control voltage input	Yellow
7	FG	Revolution pulse output	Brown

P30 Expansion Valve Coil
Recommended Drive Condition
Unipolar Drive, 1-2 Phase Excitation.

1(Red) - 3(Blue)	Coil resistance ≈ 46.0 Ω (20 °C)
1(Red) - 4(Orange)	
1(Red) - 5(Yellow)	
1(Red) - 6(White)	

Compressor Winding Resistance

U-V	1.916 Ω (20 °C)
V-W	
U-W	

P650 DC Fan Motor

Pin No.	Terminal code	Function of terminal	Lead wire color
1	Vm	Motor power voltage input	Red
2	—	—	—
3	—	—	—
4	GND	GND	Black
5	Vcc	Control power voltage input	White
6	Vsp	Speed control voltage input	Yellow
7	FG	Revolution pulse output	Brown

P30 Expansion Valve Coil
Recommended Drive Condition
Unipolar Drive, 1-2 Phase Excitation.

1(Red) - 3(Blue)	Coil resistance ≈ 46.0 Ω (20 °C)
1(Red) - 4(Orange)	
1(Red) - 5(Yellow)	
1(Red) - 6(White)	

Models : AOYG30KBTB
 AOYG36KBTB
 AOYG45KBTB

INVERTER ASSEMBLY
 AOYG30KBTB : EZ-0182AHUE
 AOYG36KBTB : EZ-0182AHUE
 AOYG45KBTB : EZ-0182BHUE

P700 Thermistor Characteristics.

Thermistor	Temperature	0 °C	20 °C	30 °C
Thermistor		0.33 k Ω	0.12 k Ω	0.08 k Ω
Thermistor (Heatsink temp.)		4.10 V	4.62 V	4.75 V

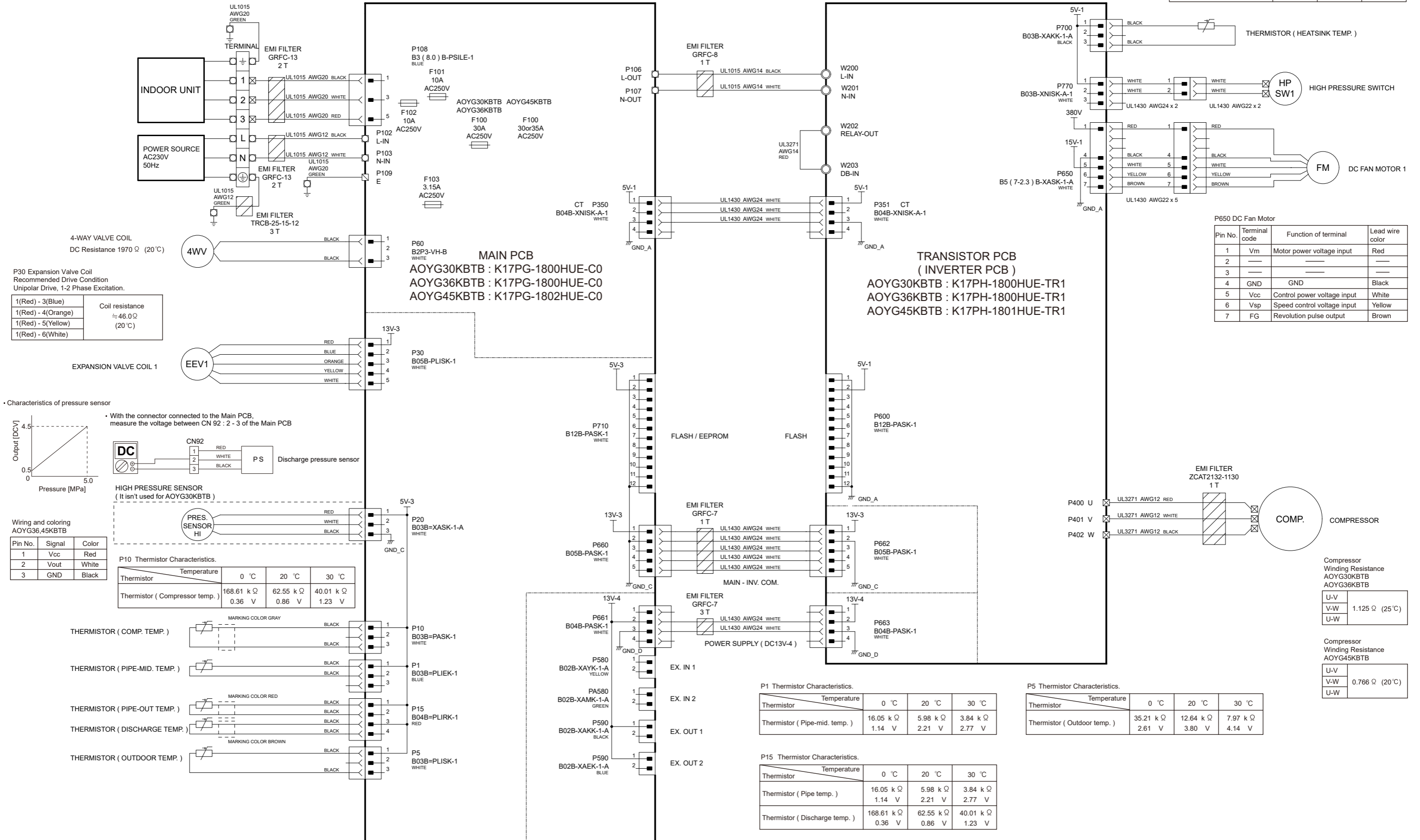

P30 Expansion Valve Coil
 Recommended Drive Condition
 Unipolar Drive, 1-2 Phase Excitation.

Coil resistance	Coil resistance
1(Red) - 3(Blue)	≈ 46.0 Ω
1(Red) - 4(Orange)	(20 °C)
1(Red) - 5(Yellow)	
1(Red) - 6(White)	

Characteristics of pressure sensor

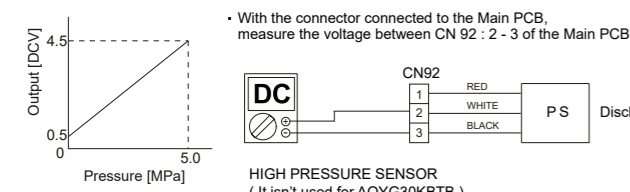

Wiring and coloring
 AOYG36,45KBTB

Pin No.	Signal	Color
1	Vcc	Red
2	Vout	White
3	GND	Black

P10 Thermistor Characteristics.

Thermistor	Temperature	0 °C	20 °C	30 °C
Thermistor		168.61 k Ω	62.55 k Ω	40.01 k Ω
Thermistor (Compressor temp.)		0.36 V	0.86 V	1.23 V

P1 Thermistor Characteristics.

Thermistor	Temperature	0 °C	20 °C	30 °C
Thermistor		16.05 k Ω	5.98 k Ω	3.84 k Ω
Thermistor (Pipe-mid. temp.)		1.14 V	2.21 V	2.77 V

P5 Thermistor Characteristics.

Thermistor	Temperature	0 °C	20 °C	30 °C
Thermistor		35.21 k Ω	12.64 k Ω	7.97 k Ω
Thermistor (Outdoor temp.)		2.61 V	3.80 V	4.14 V

P15 Thermistor Characteristics.

Thermistor	Temperature	0 °C	20 °C	30 °C
Thermistor		16.05 k Ω	5.98 k Ω	3.84 k Ω
Thermistor (Pipe temp.)		1.14 V	2.21 V	2.77 V
Thermistor (Discharge temp.)		168.61 k Ω	62.55 k Ω	40.01 k Ω
		0.36 V	0.86 V	1.23 V

P650 DC Fan Motor

Pin No.	Terminal code	Function of terminal	Lead wire color
1	Vm	Motor power voltage input	Red
2			
3			
4	GND	GND	Black
5	Vcc	Control power voltage input	White
6	Vsp	Speed control voltage input	Yellow
7	FG	Revolution pulse output	Brown

Compressor
 Winding Resistance
 AOYG30KBTB
 AOYG36KBTB

U-V	1.125 Ω (25 °C)
V-W	
U-W	

Compressor
 Winding Resistance
 AOYG45KBTB

U-V	0.766 Ω (20 °C)
V-W	
U-W	

Error codes (All indoor units)

If you use a wired type remote controller, error codes will appear on the remote controller display. If you use a wireless remote controller, the lamps on the IR receiver unit will output error codes by way of blinking patterns. See the lamp blinking patterns and error codes in the table below. An error display is displayed only during operation.

Error display			Wired remote controller Error code	Description
OPERATION lamp (green)	TIMER lamp (orange)	ECONOMY lamp (green)		
●(1)	●(1)	◇	11	Serial communication error
●(1)	●(2)	◇	12	Wired remote controller communication error
●(1)	●(5)	◇	15	Check run unfinished
●(2)	●(1)	◇	21	Unit number or Refrigerant circuit address setting error [Simultaneous Multi]
●(2)	●(2)	◇	22	Indoor unit capacity error
●(2)	●(3)	◇	23	Combination error
●(2)	●(4)	◇	24	• Connection unit number error (indoor secondary unit) [Simultaneous Multi] • Connection unit number error (indoor unit or branch unit) [Flexible Multi]
●(2)	●(7)	◇	27	Primary unit, secondary unit setup error [Simultaneous Multi]
●(3)	●(1)	◇	31	Power supply interruption error
●(3)	●(2)	◇	32	Indoor unit PCB model information error
●(3)	●(5)	◇	35	Manual auto switch error
●(4)	●(1)	◇	41	Room temp. sensor error
●(4)	●(2)	◇	42	Indoor unit Heat Ex. Middle temp. sensor error
●(5)	●(1)	◇	51	Indoor unit fan motor error
●(5)	●(3)	◇	53	Drain pump error
●(5)	●(7)	◇	57	Damper error
●(5)	●(15)	◇	5U	Indoor unit error
●(6)	●(2)	◇	62	Outdoor unit main PCB model information error or communication error
●(6)	●(3)	◇	63	Inverter error
●(6)	●(4)	◇	64	Active filter error, PFC circuit error
●(6)	●(5)	◇	65	Trip terminal L error
●(6)	●(10)	◇	6A	Display PCB microcomputers communication error
●(7)	●(1)	◇	71	Discharge temp. sensor error
●(7)	●(2)	◇	72	Compressor temp. sensor error
●(7)	●(3)	◇	73	Outdoor unit Heat Ex. liquid temp. sensor error

Error display			Wired remote controller Error code	Description
OPERATION lamp (green)	TIMER lamp (orange)	ECONOMY lamp (green)		
●(7)	●(4)	◇	74	Outdoor temp. sensor error
●(7)	●(5)	◇	75	Suction Gas temp. sensor error
●(7)	●(6)	◇	76	• 2-way valve temp. sensor error • 3-way valve temp. sensor error
●(7)	●(7)	◇	77	Heat sink temp. sensor error
●(8)	●(2)	◇	82	• Sub-cool Heat Ex. gas inlet temp. sensor error • Sub-cool Heat Ex. gas outlet temp. sensor error
●(8)	●(3)	◇	83	Liquid pipe temp. sensor error
●(8)	●(4)	◇	84	Current sensor error
●(8)	●(6)	◇	86	• Discharge pressure sensor error • Suction pressure sensor error • High pressure switch error
●(9)	●(4)	◇	94	Trip detection
●(9)	●(5)	◇	95	Compressor rotor position detection error (permanent stop)
●(9)	●(7)	◇	97	Outdoor unit fan motor 1 error
●(9)	●(8)	◇	98	Outdoor unit fan motor 2 error
●(9)	●(9)	◇	99	4-way valve error
●(9)	●(10)	◇	9A	Coil (expansion valve) error
●(10)	●(1)	◇	A1	Discharge temp. error
●(10)	●(3)	◇	A3	Compressor temp. error
●(10)	●(4)	◇	A4	High pressure error
●(10)	●(5)	◇	A5	Low pressure error
●(13)	●(2)	◇	J2	Branch boxes error [Flexible Multi]

Display mode ● : 0.5s ON / 0.5s OFF
◇ : 0.1s ON / 0.1s OFF
() : Number of flashing

Error codes (Outdoor unit)

AOYG30,36,45KBTB

You can determine the operating status by the lighting on and blinking of the LED display.

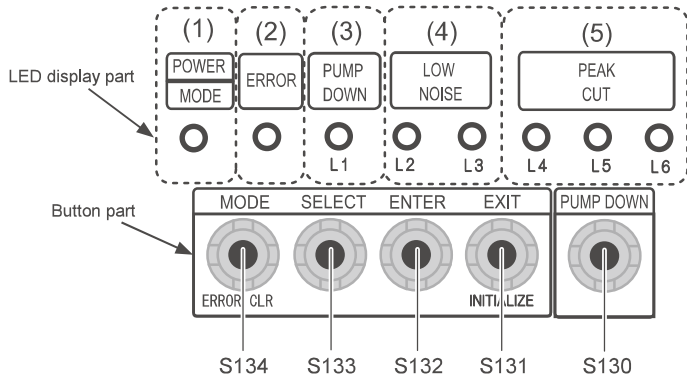

Error display mode

Display when an error occurs.

POWER/ MODE	ERROR	PUMP DOWN (L1)	LOW NOISE		PEAK CUT		
			(L2)	(L3)	(L4)	(L5)	(L6)
●	Blink (Hi speed)	○	○	○	○	○	○

Sign "○": Lights off, "●": Lights on

- Check that the "ERROR" LED blinks, then press the [ENTER] button (S132) once.

10.2. Error code check table

DESCRIPTION	REMARK	LED display							
		POWER/ MODE	ERROR	PUMP DOWN (L1)	LOW NOISE		PEAK CUT		
				(L1)	(L2)	(L3)	(L4)	(L5)	(L6)
Serial communication error	Serial forward transmission error immediately after operation	Blink (2 times)	●	Blink (1 time)	Blink (1 time)	○	○	●	●
	Serial forward transmission error during operation	Blink (2 times)	●	Blink (1 time)	Blink (1 time)	○	●	○	○
Indoor unit capacity error	Indoor unit capacity error	Blink (2 times)	●	Blink (2 times)	Blink (2 times)	○	○	○	●
Indoor unit error	Indoor unit error	Blink (2 times)	●	Blink (5 times)	Blink (15 times)	○	○	○	●
Outdoor unit main PCB error	Outdoor unit PCB model information error	Blink (2 times)	●	Blink (6 times)	Blink (2 times)	○	○	○	●
Inverter PCB error	Inverter error	Blink (2 times)	●	Blink (6 times)	Blink (3 times)	○	○	○	●
IPM error	Trip terminal L error	Blink (2 times)	●	Blink (6 times)	Blink (5 times)	○	○	●	●
Discharge temp. sensor error	Discharge temp. sensor 1 error	Blink (2 times)	●	Blink (7 times)	Blink (1 time)	○	○	○	●
Compressor temp. sensor error	Compressor temp. sensor 1 error	Blink (2 times)	●	Blink (7 times)	Blink (2 times)	○	○	○	●
Outdoor unit Heat Ex. sensor error	Heat Ex. center temp. sensor error	Blink (2 times)	●	Blink (7 times)	Blink (3 times)	○	○	●	○
	Outdoor unit Heat Ex. liquid temp. sensor error	Blink (2 times)	●	Blink (7 times)	Blink (3 times)	○	○	●	●
Outdoor temp. sensor error	Outdoor temp. sensor error	Blink (2 times)	●	Blink (7 times)	Blink (4 times)	○	○	○	●
Heat sink temp. sensor error	Heat sink temp. sensor error	Blink (2 times)	●	Blink (7 times)	Blink (7 times)	○	○	○	●
Current sensor error	Current sensor 1 error (stoppage permanently)	Blink (2 times)	●	Blink (8 times)	Blink (4 times)	○	○	○	●
Pressure sensor error	High pressure switch 1 error	Blink (2 times)	●	Blink (8 times)	Blink (6 times)	○	●	○	○
	Pressure sensor error	Blink (2 times)	●	Blink (8 times)	Blink (6 times)	○	●	●	○
Trip detection	Trip detection	Blink (2 times)	●	Blink (9 times)	Blink (4 times)	○	○	○	●
Compressor motor control error	Rotor position detection error (stoppage permanently)	Blink (2 times)	●	Blink (9 times)	Blink (5 times)	○	○	○	●
Outdoor unit fan motor 1 error	Duty abnormal	Blink (2 times)	●	Blink (9 times)	Blink (7 times)	○	○	●	●
Outdoor unit fan motor 2 error	Duty abnormal	Blink (2 times)	●	Blink (9 times)	Blink (8 times)	○	○	●	●
4-way valve error	4-way valve error	Blink (2 times)	●	Blink (9 times)	Blink (9 times)	○	○	○	●
Discharge temp. 1 error	Discharge temp. 1 error	Blink (2 times)	●	Blink (10 times)	Blink (1 time)	○	○	○	●
Compressor temp. error	Compressor 1 temp. error	Blink (2 times)	●	Blink (10 times)	Blink (3 times)	○	○	○	●
Pressure error 2	Low pressure error	Blink (2 times)	●	Blink (10 times)	Blink (5 times)	○	○	○	●
IPM error	Temp. error	Blink (2 times)	●	Blink (6 times)	Blink (5 times)	○	○	○	●
Heat sink temp. error	Heat sink temp. error	Blink (2 times)	●	Blink (10 times)	Blink (12 times)	○	○	●	●

Parts

INDOOR UNIT
ARXG24KMLA
ARXG30KMLA
ARXG36KMLA
ARXG45KMLA

Hook metal

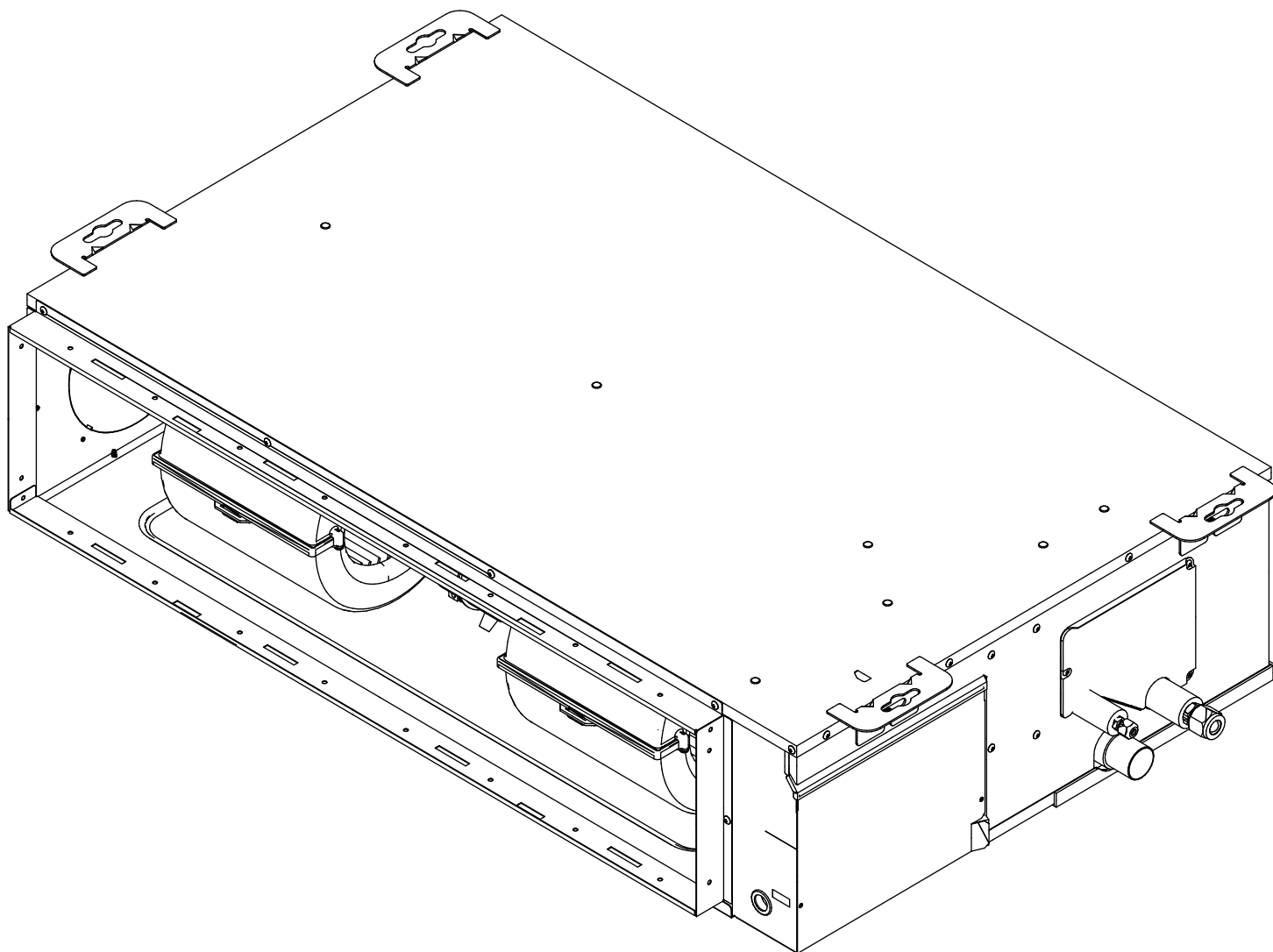

Ref.	Description	Part number
1	Room thermistor	9900826048
2	Pipe thermistor	9900942045

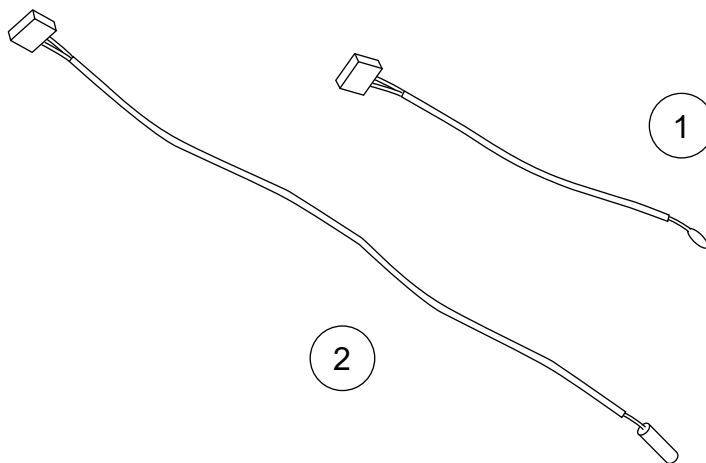

INDOOR UNIT
 ARXG24KMLA
 ARXG30KMLA
 ARXG36KMLA
 ARXG45KMLA

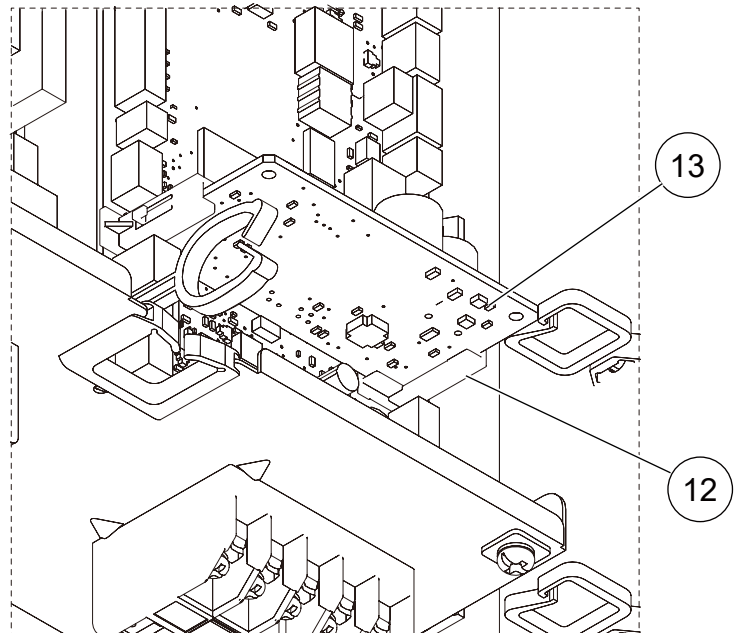
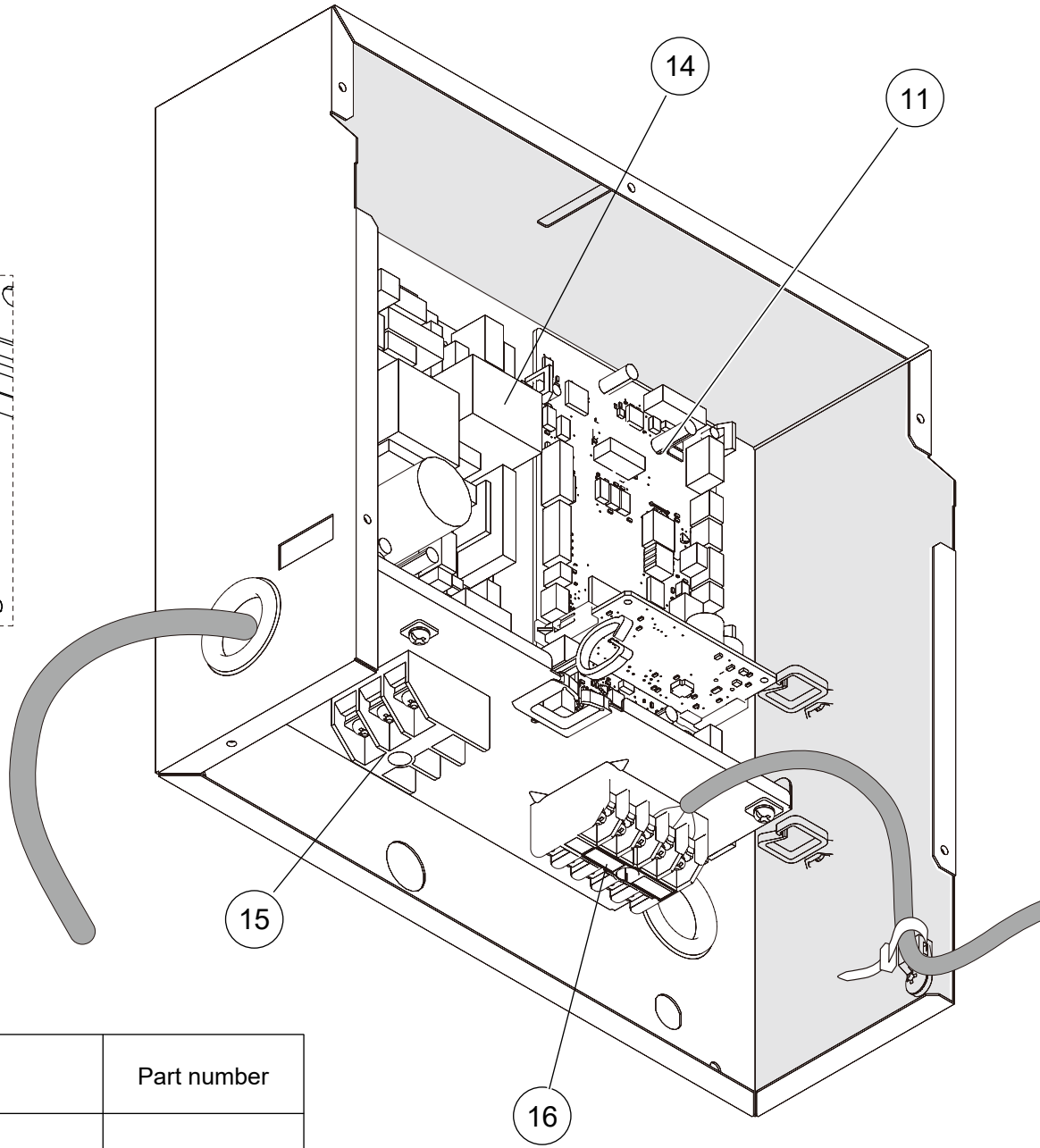
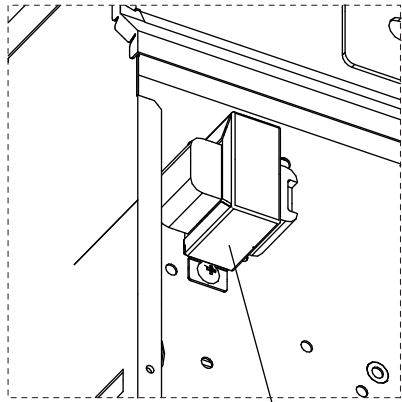

Ref.	Description	Part number
11	Main PCB (24KMLA)	9710624223
11	Main PCB (30KMLA)	9710624230
11	Main PCB (36KMLA)	9710624247
11	Main PCB (45KMLA)	9710624254
12	Holder	0600063023
13	Communication PCB	9710019005
14	Power supply PCB	9710661013
15	Terminal 3P	9306489045
16	Terminal 5P	9900896003
17	Reactor assy	9707457049

INDOOR UNIT
 ARXG24KMLA
 ARXG30KMLA
 ARXG36KMLA
 ARXG45KMLA

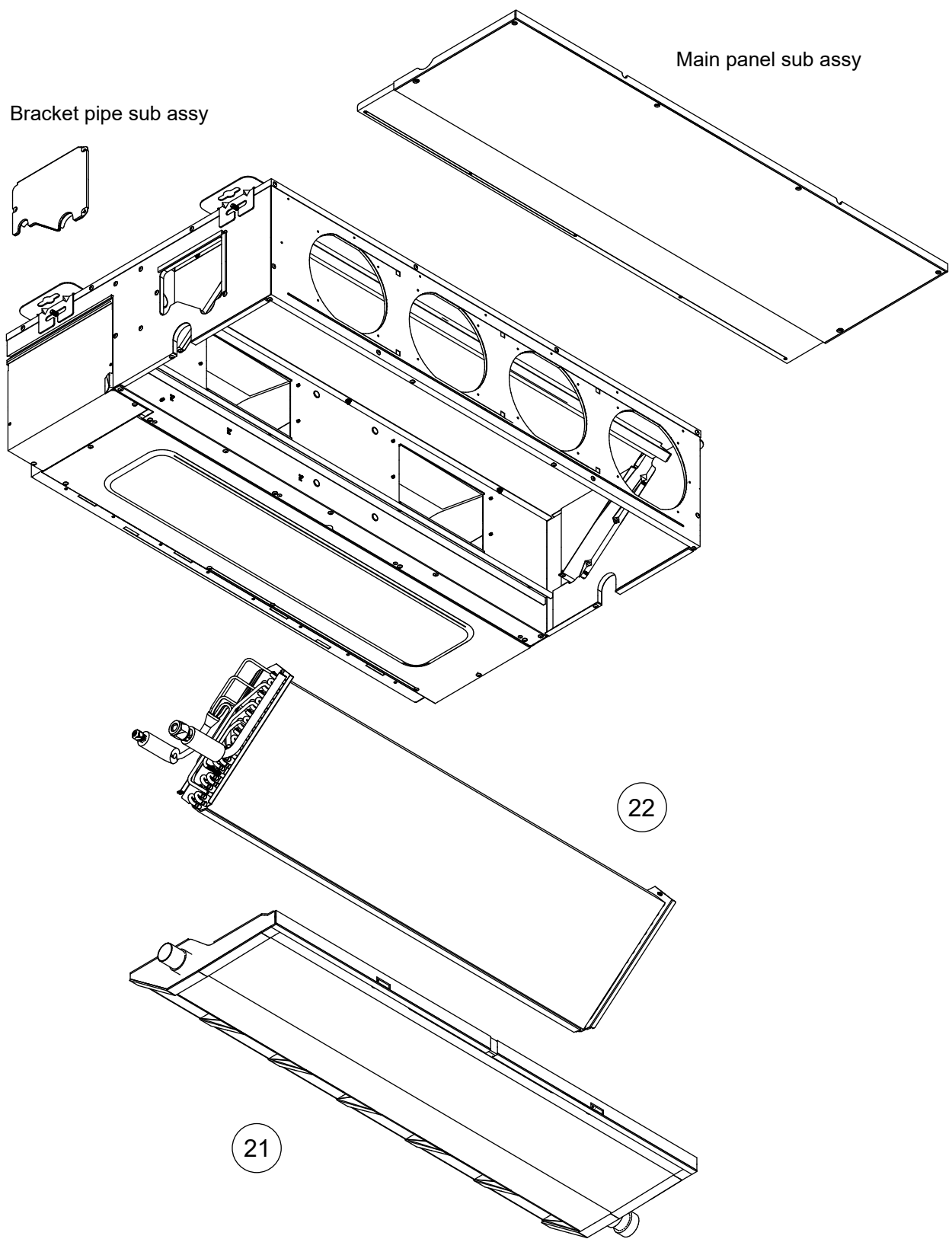

Ref.	Description	Part number
21	Drain pan sub assy	9374513017
22	Evaporator Total Assy (24KMLA)	9374517978
22	Evaporator Total Assy (30, 36KMLA)	9383816048
22	Evaporator Total Assy (45KMLA)	9383816031

INDOOR UNIT
ARXG24KMLA

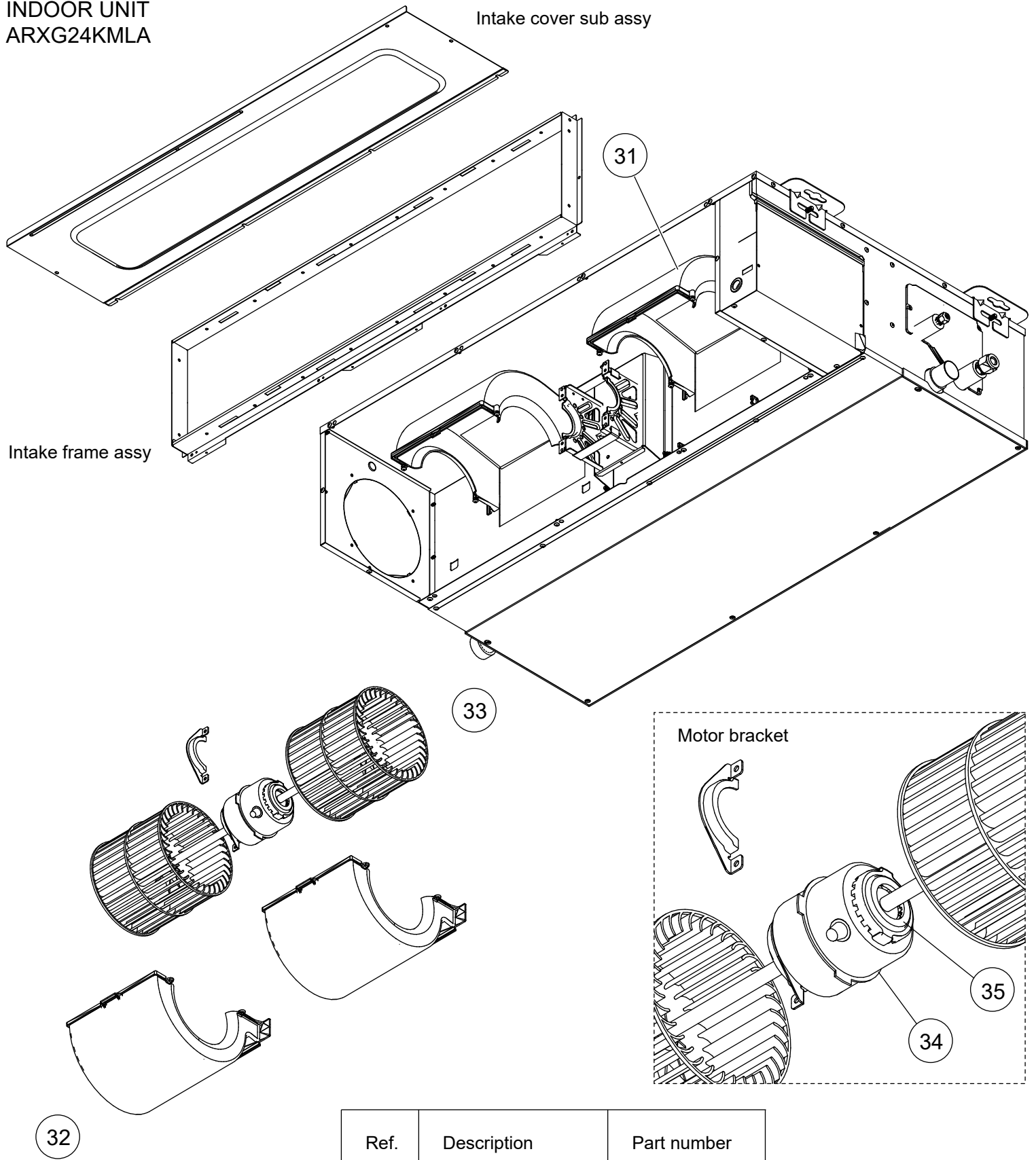

Ref.	Description	Part number
31	Casing A	9374233021
32	Casing B	9374234028
33	Sirocco fan assy	9356531060
34	Fan motor assy	9380718031
35	Rubber	9385102002

INDOOR UNIT
 ARXG30KMLA
 ARXG36KMLA
 ARXG45KMLA

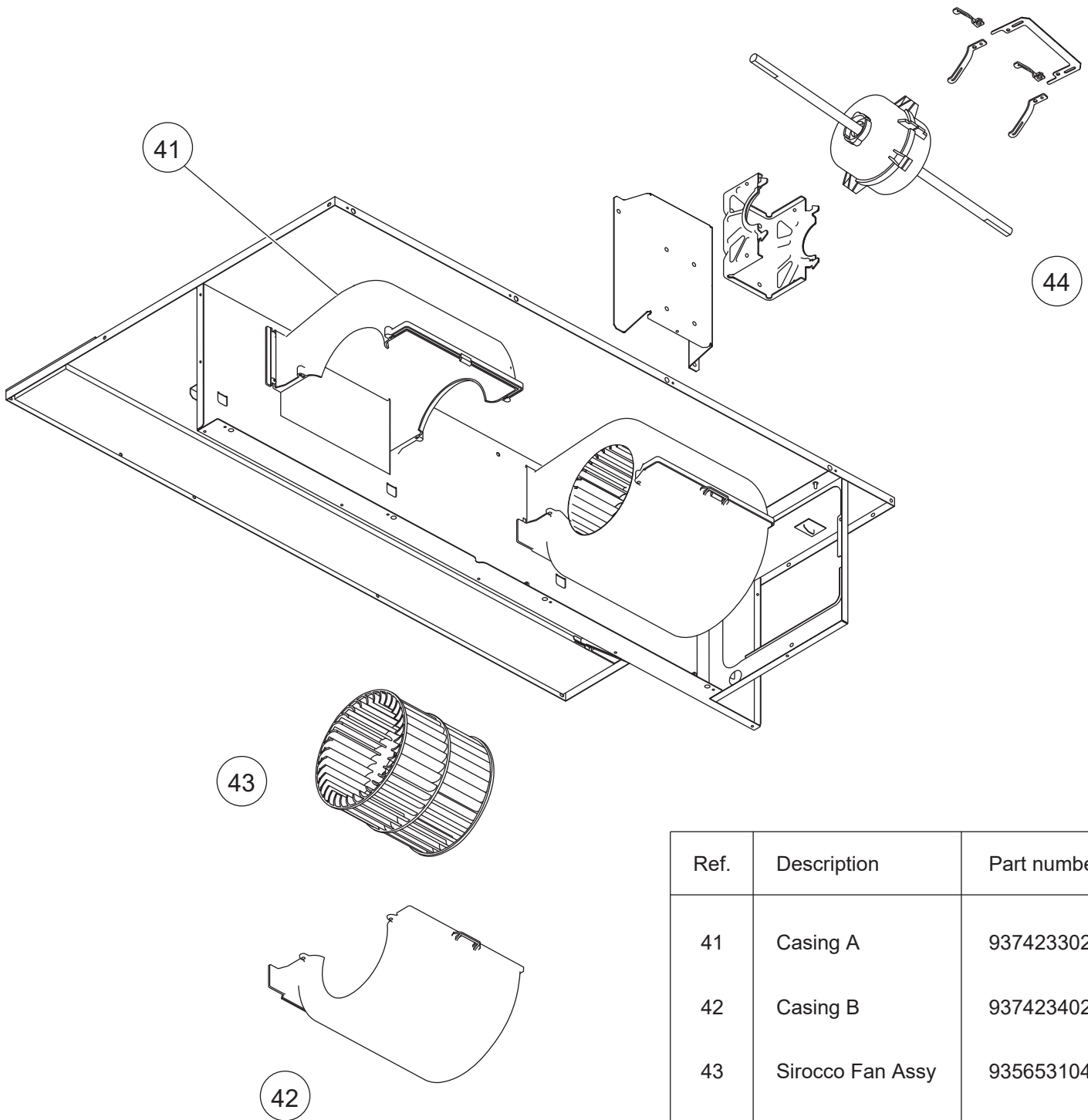

Ref.	Description	Part number
41	Casing A	9374233021
42	Casing B	9374234028
43	Sirocco Fan Assy	9356531046
44	Fan Motor	9603213015

OUTDOOR UNIT
AOYG24KBTB

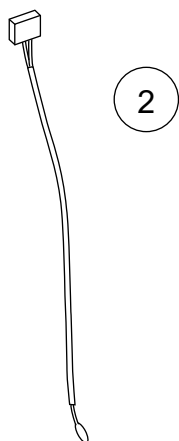
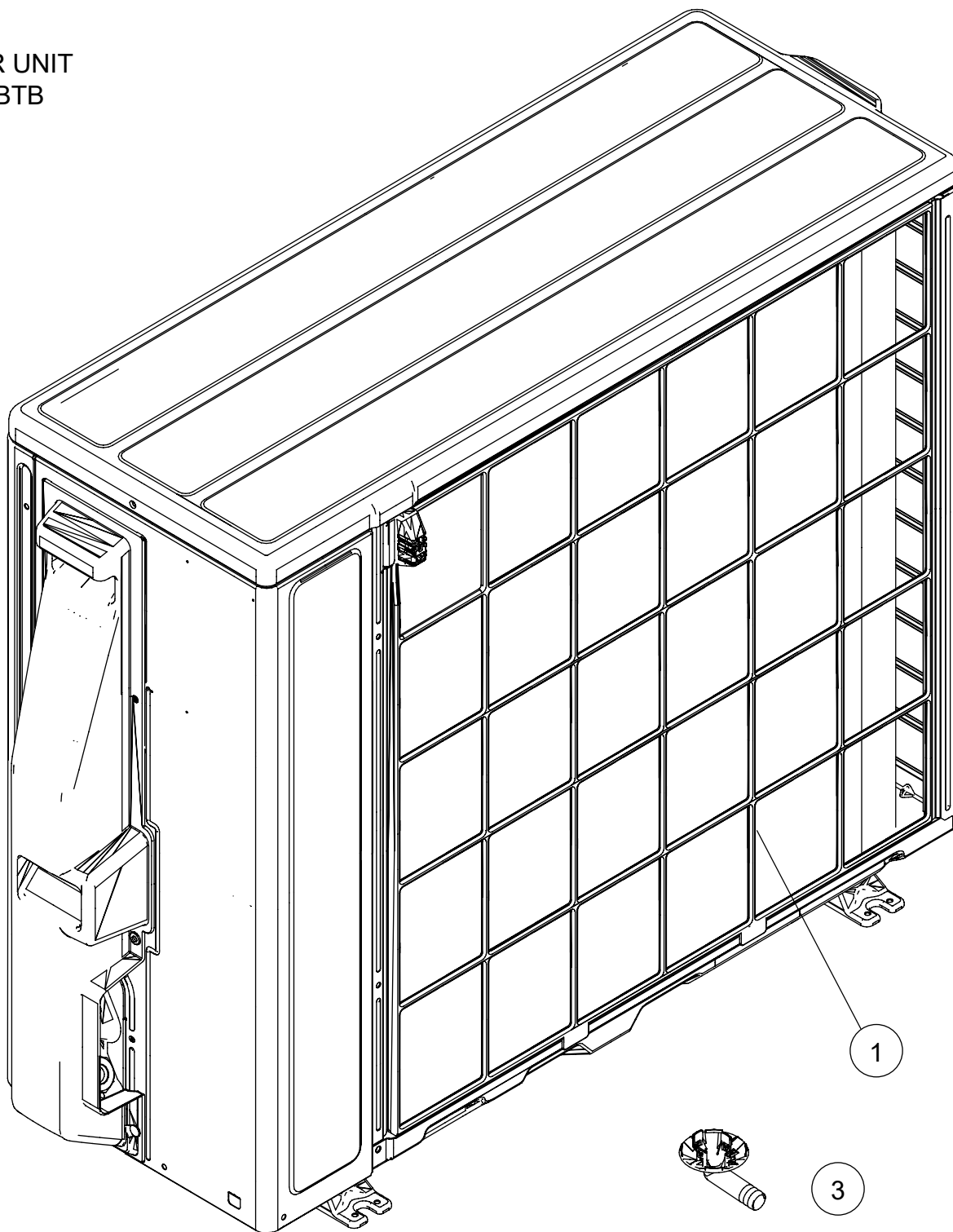

Ref.	Description	Part number
1	Protective net assy	9322811042
2	Outdoor thermistor	9900585060
3	Drain pipe	9322144003

OUTDOOR UNIT
AOYG24KBTB

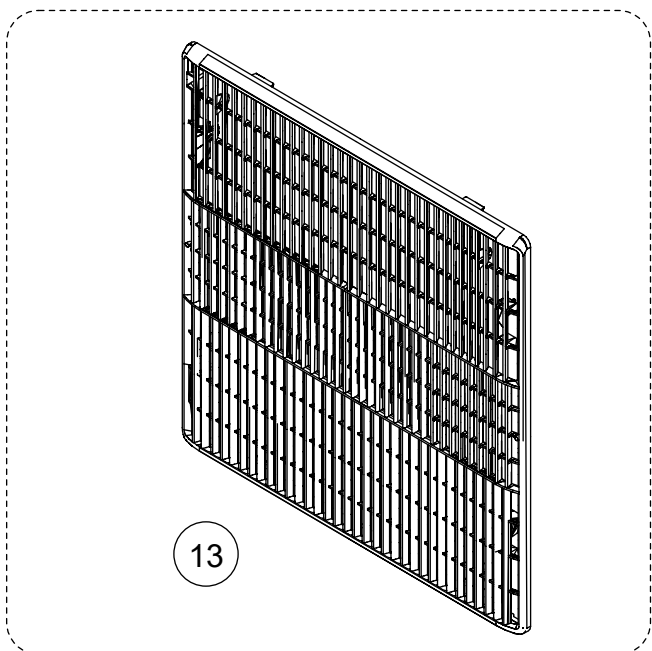
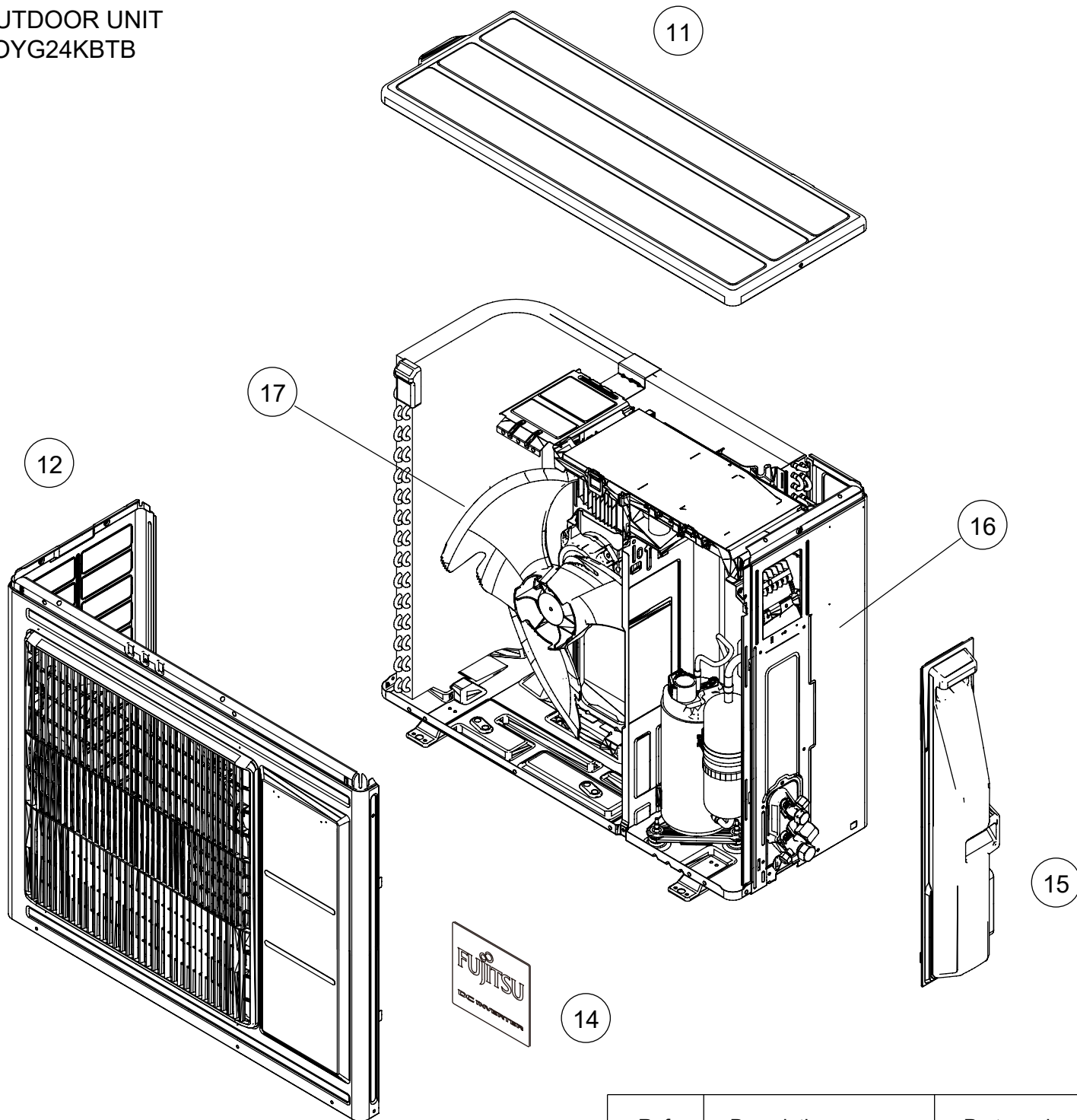

Ref.	Description	Part number
11	Top panel assy	9322556073
12	Front panel assy	9322555038
13	Blow grille	9322149008
14	Emblem	9319151007
15	Switch cover assy	9322570031
16	Cabinet right Assy	9322552150
17	Propeller fan	9322150004

OUTDOOR UNIT
AOYG24KBTB

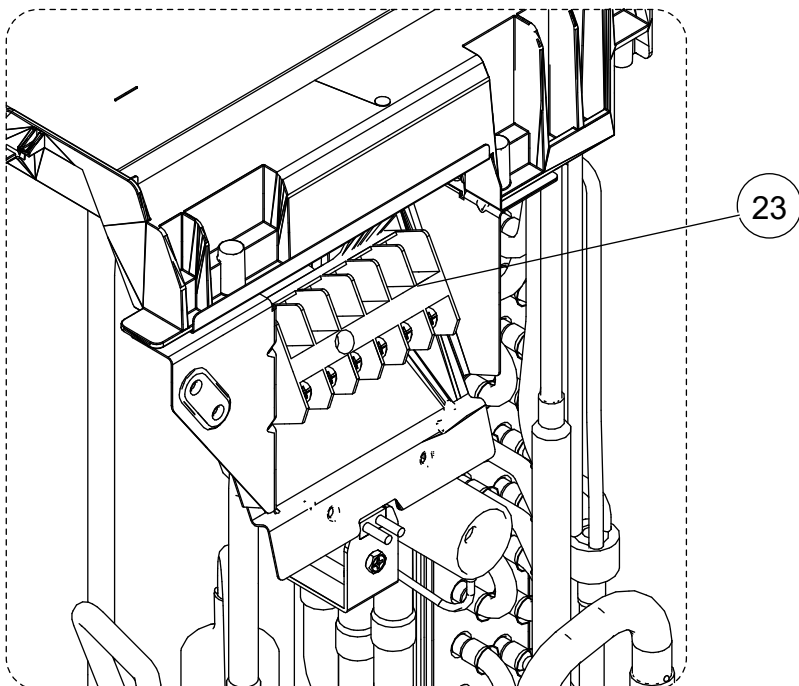
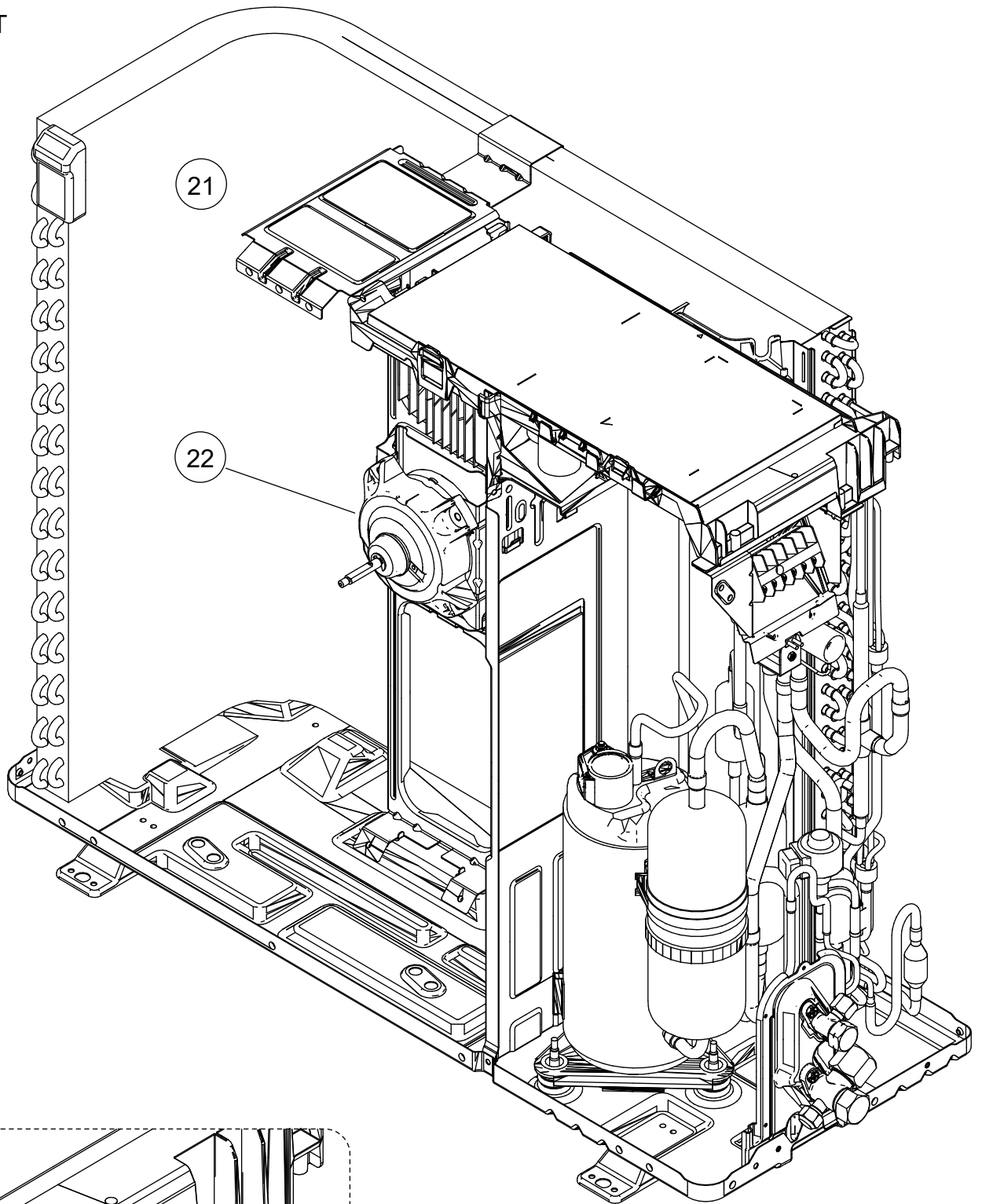

Ref.	Description	Part number
21	Motor bracket assy	9322553034
22	Brushless motor	9603601003
23	Terminal	9900435028

OUTDOOR UNIT
AOYG24KBTB

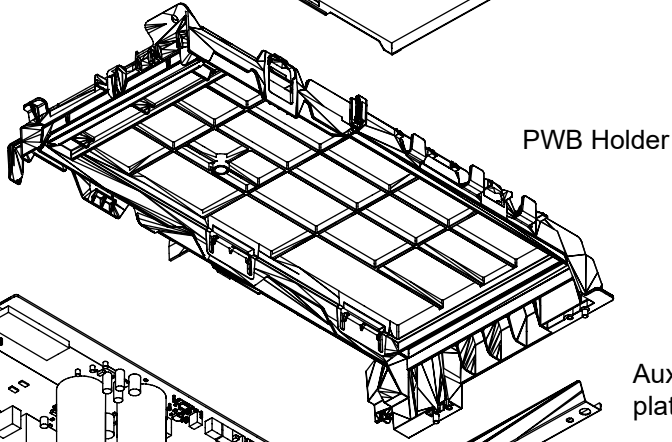
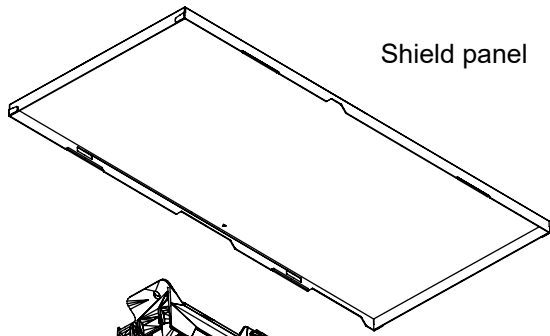

31

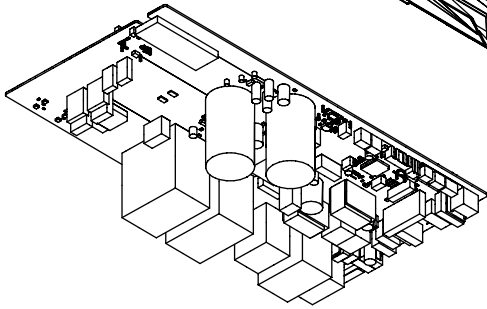

Auxiliary plate

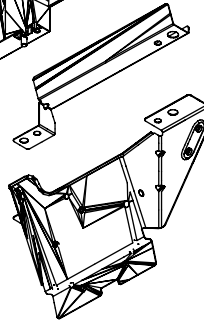

Terminal bracket assy

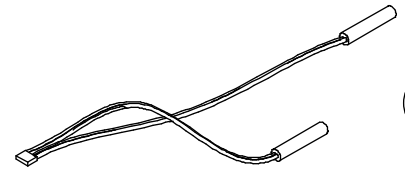
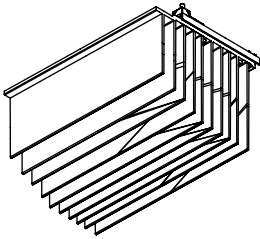

33

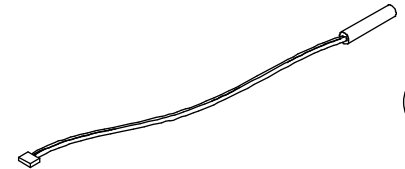

34

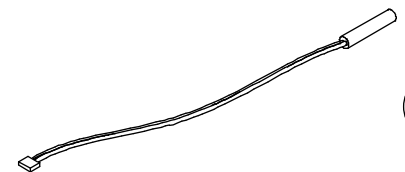

35

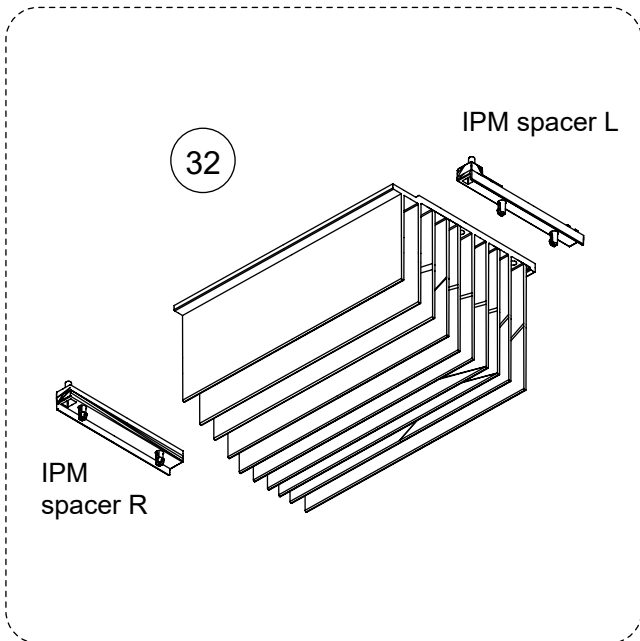
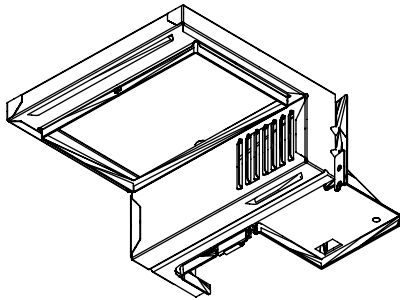

32

Ref.	Description	Part number
31	Main PCB, Service unit	9709683408
32	Heatsink	9322421043
33	Thermistor assy	9900727116
34	Heat exchanger thermistor	9900984014
35	Compressor thermistor	9900985011

OUTDOOR UNIT
AOYG24KBTB

Hair pin
cushion

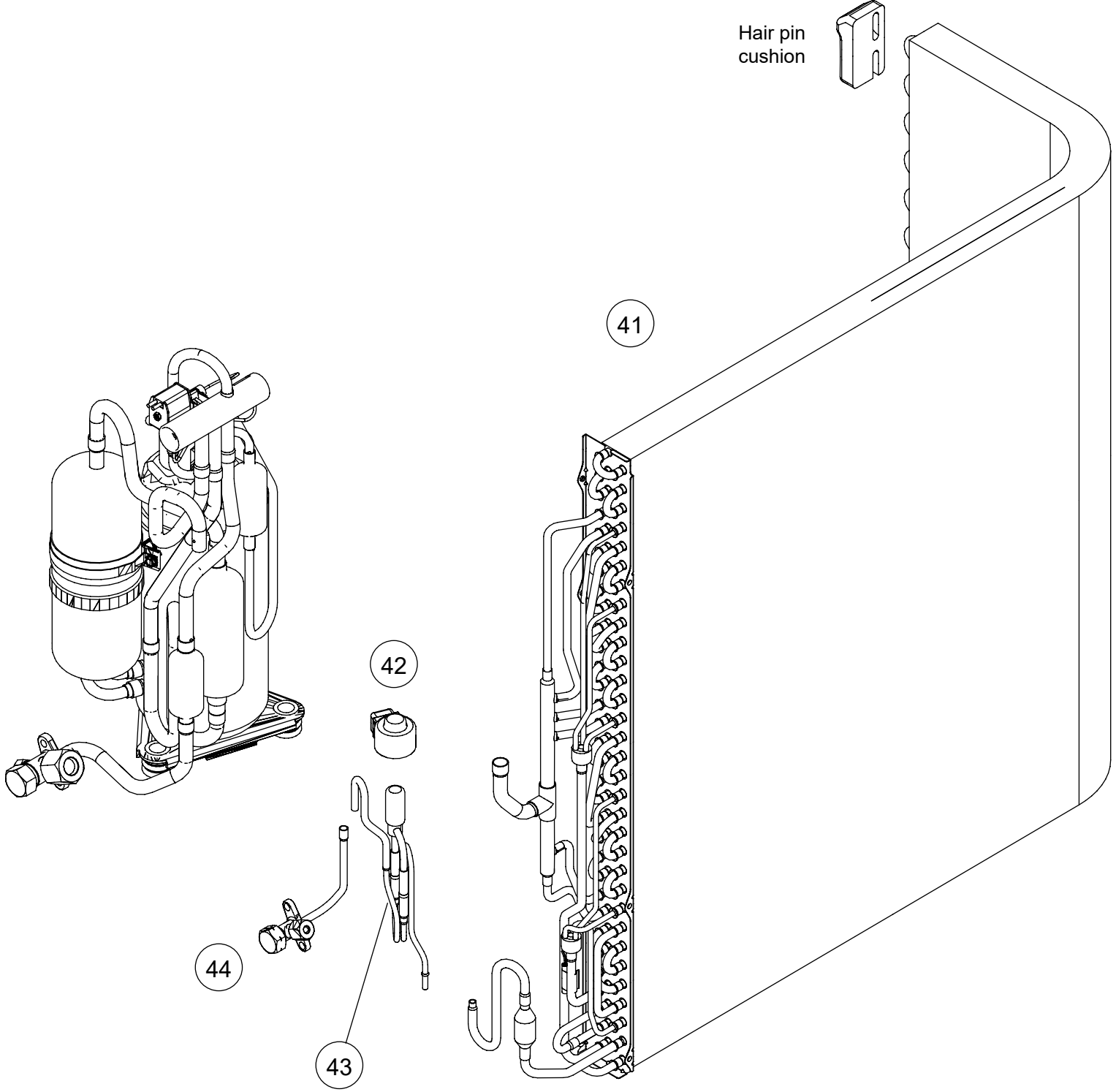

Ref.	Description	Part number
41	Condenser total assy	9317089630
42	Expansion valve coil	9970173028
43	Pulse motor valve assy	9322463029
44	2-way valve assy	9322474001

OUTDOOR UNIT
AOYG24KBTB

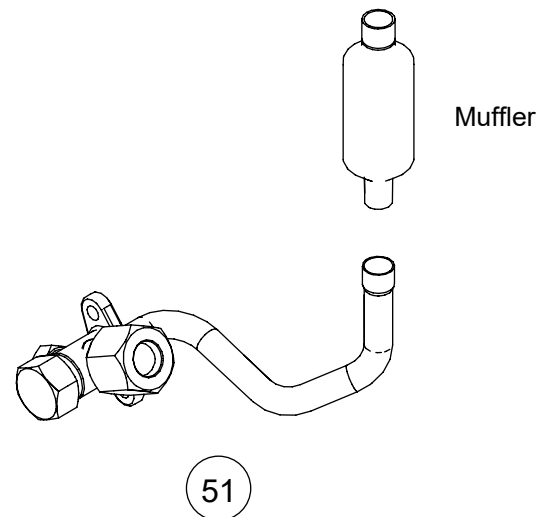
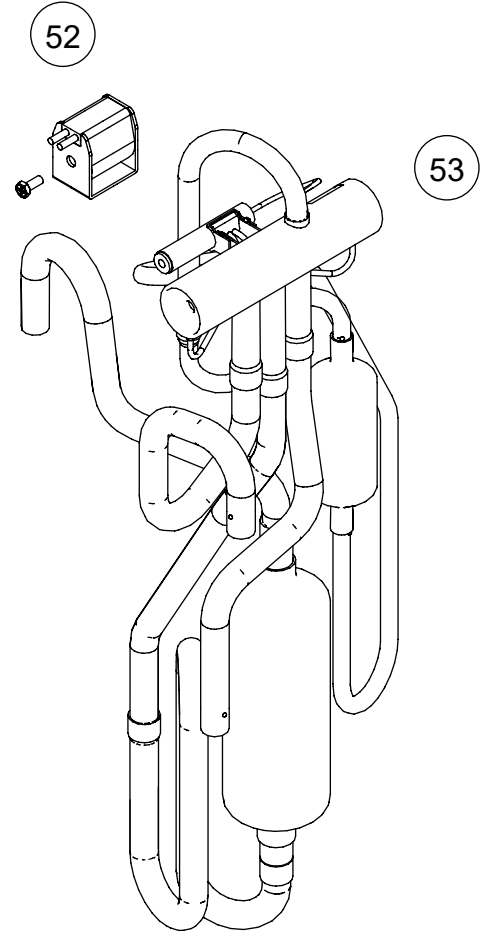
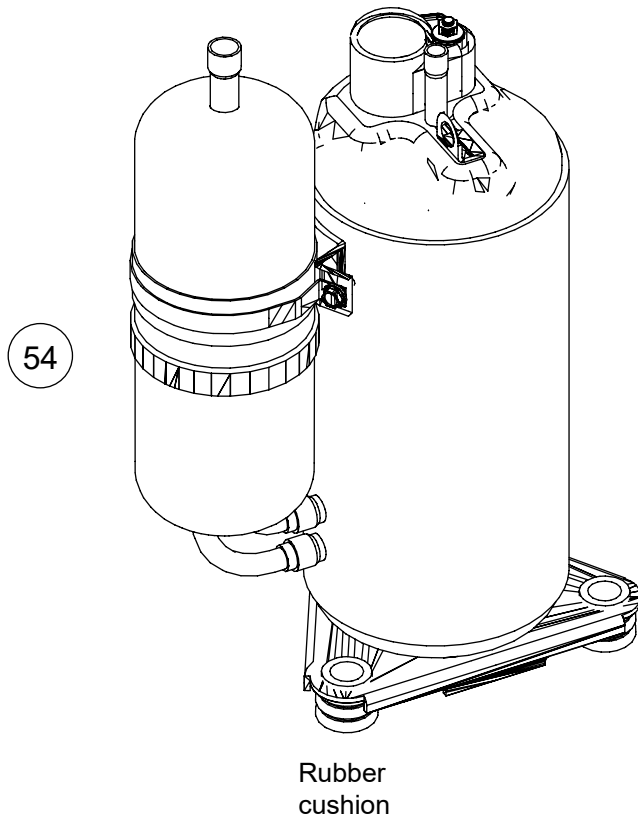

Ref.	Description	Part number
51	3-way valve assy	9387831016
52	Solenoid	9970206009
53	4-way valve assy	9383129025
54	Compressor	9810521002
-	S-insulator B	9322503008
-	S-insulator F	9322529008
-	S-insulator H	9322501004
-	S-insulator V	9323045002
-	S-insulator K	9322824004

OUTDOOR UNIT
AOYG30KBTB
AOYG36KBTB

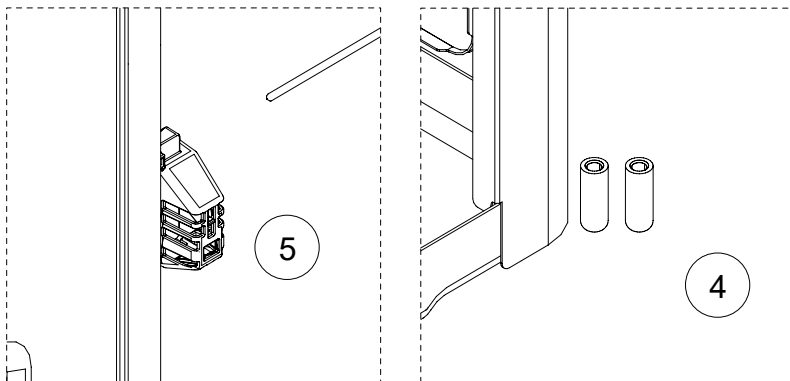
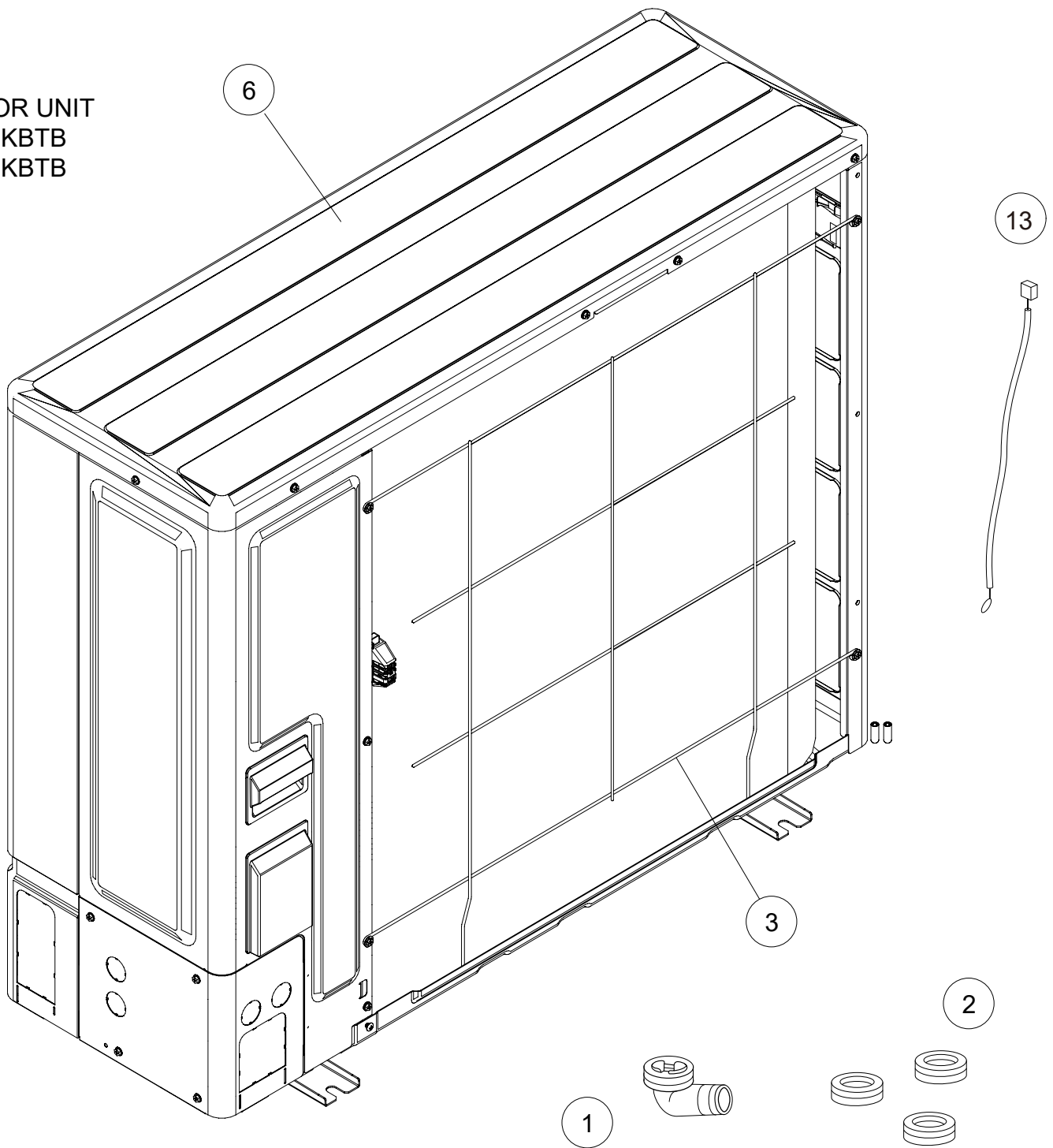

Ref.	Description	Parts number
1	Drain assy	9303029015
2	Drain cap	313166024302
3	Protective net rear	9383779008
4	Rubber (net)	9375361013
5	Thermo holder	9383607004
6	Top panel sub assy	9383880001
13	Outdoor Thermistor	9900565091

OUTDOOR UNIT
 AOYG30KBTB
 AOYG36KBTB

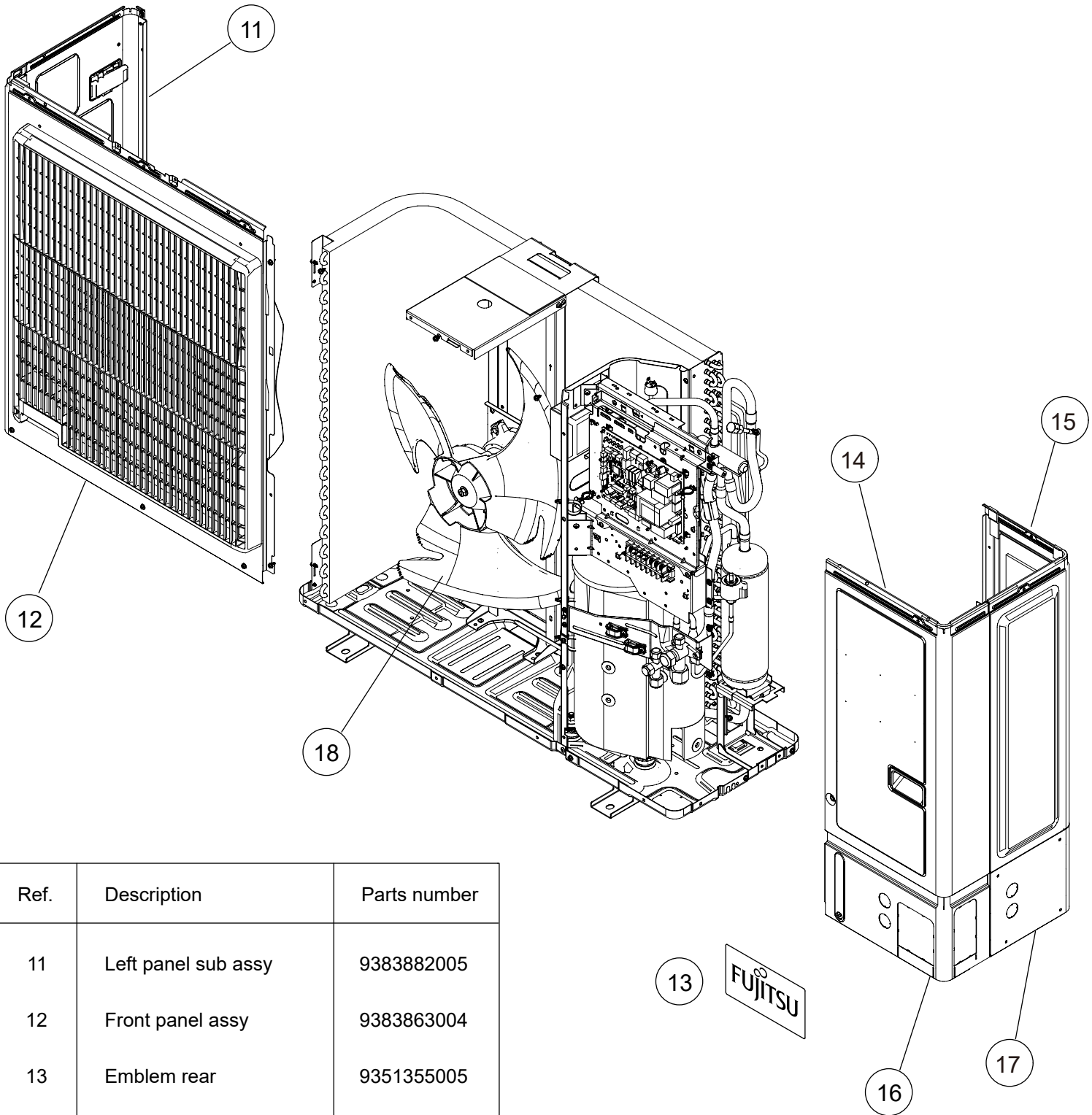

Ref.	Description	Parts number
11	Left panel sub assy	9383882005
12	Front panel assy	9383863004
13	Emblem rear	9351355005
14	Service panel sub assy	9383876004
15	Right panel sub assy	9383874000
16	Pipe cover front	9383878008
17	Pipe cover rear	9383879005
18	Propeller fan	9383336003

OUTDOOR UNIT
 AOYG30KBTB
 AOYG36KBTB

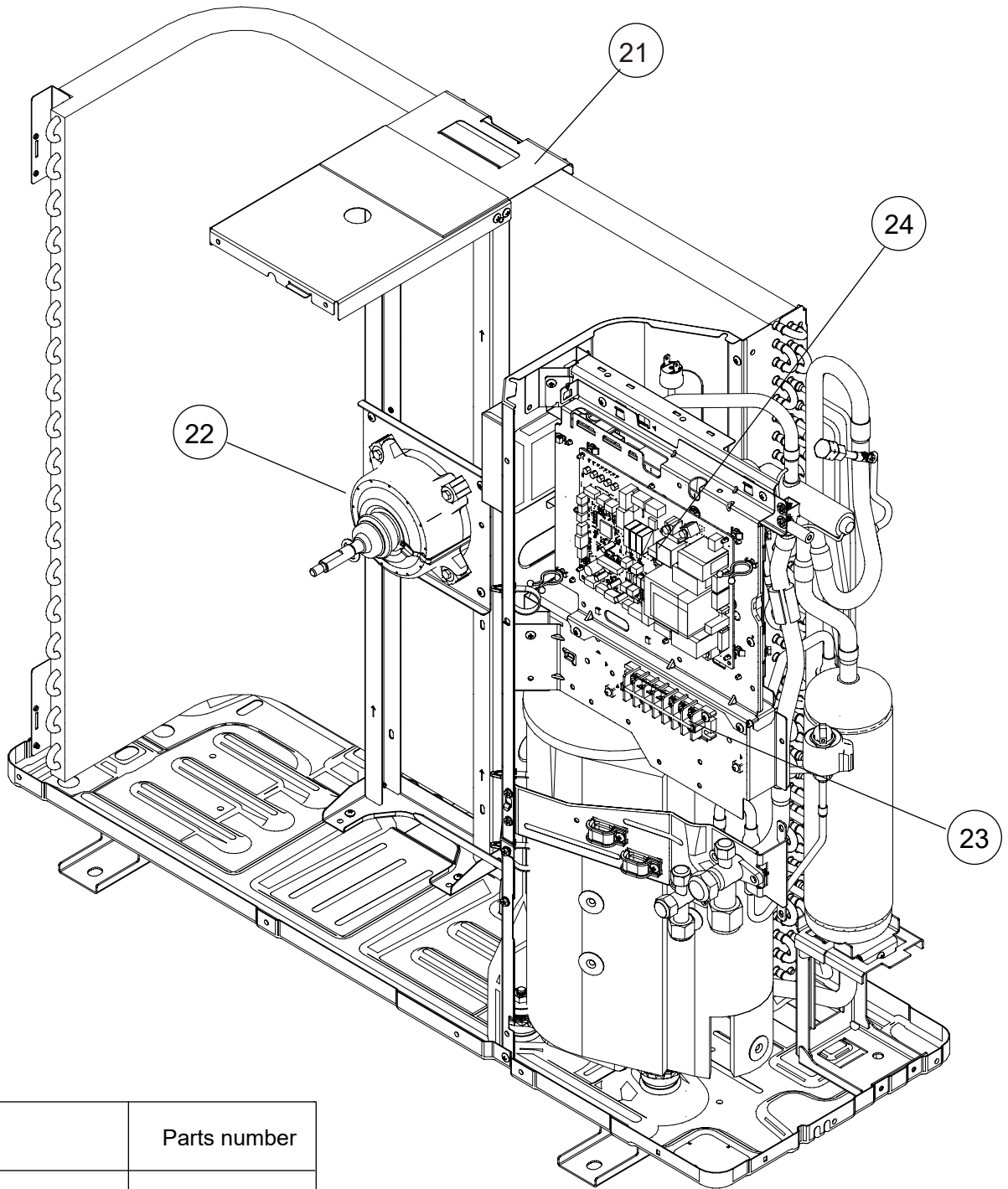

Ref.	Description	Parts number
21	Motor bracket assy	9383862007
22	Motor, DC Brushless	9603732011
23	Terminal 7P	9900203061
24	Main PCB (Service) (30)	9711431004
24	Main PCB (Service) (36)	9711431011
25	Inverter PCB	9711233004
--	Heat ex. thermistor	9900984038
--	Thermistor assy	9900727154
--	Compressor thermistor	9900985035

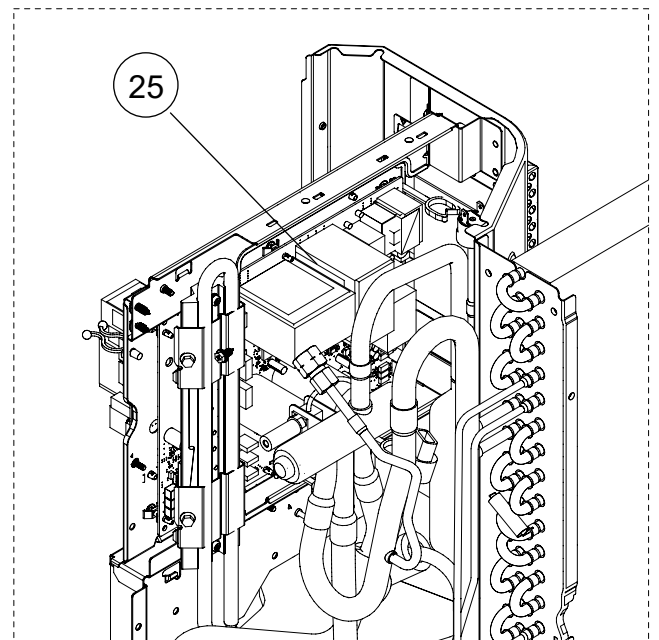

OUTDOOR UNIT
 AOYG30KBTB
 AOYG36KBTB

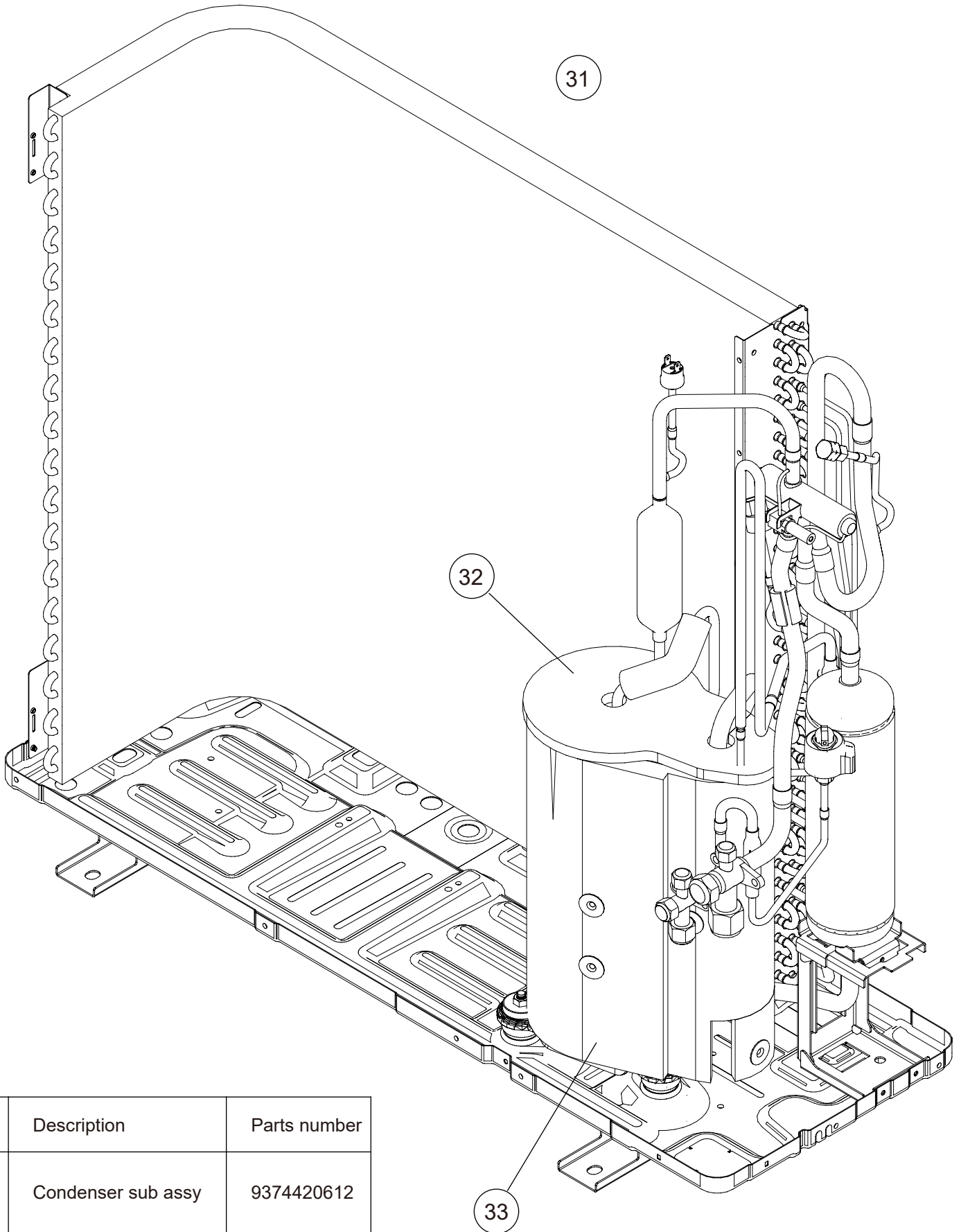

Ref.	Description	Parts number
31	Condenser sub assy	9374420612
32	S-ABS (top)	9380516064
33	S-ABS (body)	9379647168

OUTDOOR UNIT
 AOYG30KBTB
 AOYG36KBTB

Ref.	Description	Parts number
41	Compressor assy	9383821004
42	Accumulator assy	9375250140
43	Solenoid	9970194016
44	4-way valve assy (30)	9374425648
44	4-way valve assy (36)	9374425631
45	pressure switch	9900186029
46	Sensor (36)	9970158018
47	Expansion valve coil	9970209000
48	Expansion valve assy	9370947328
49	3-way valve assy	9377958037
50	3-way valve assy	9379079013

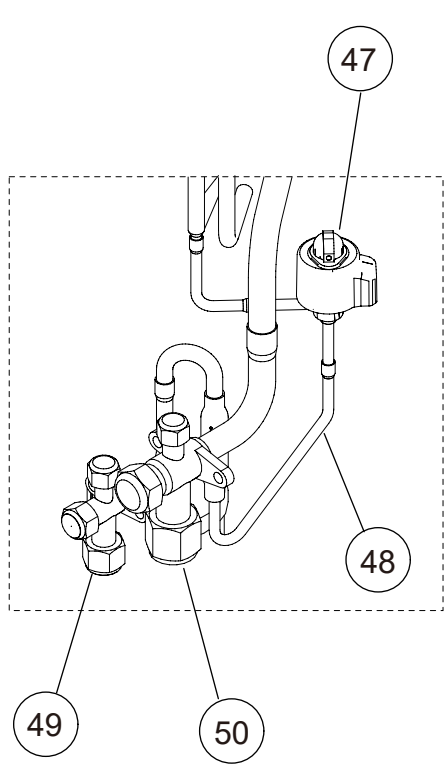
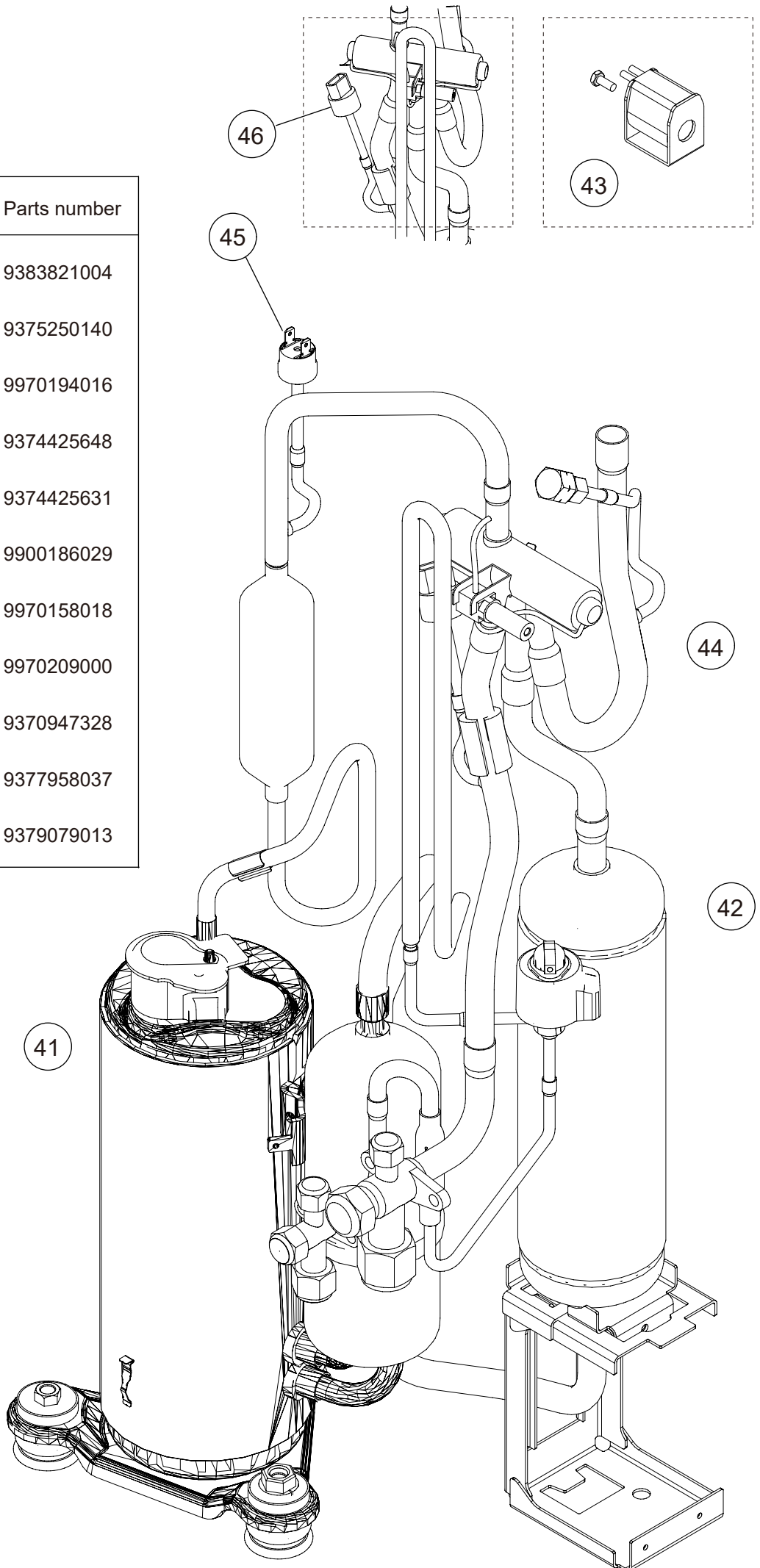

PARTS

OUTDOOR UNIT
AOYG45KBTB

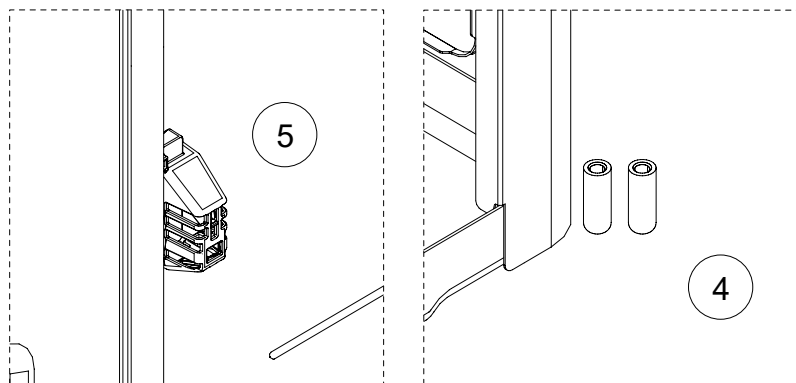
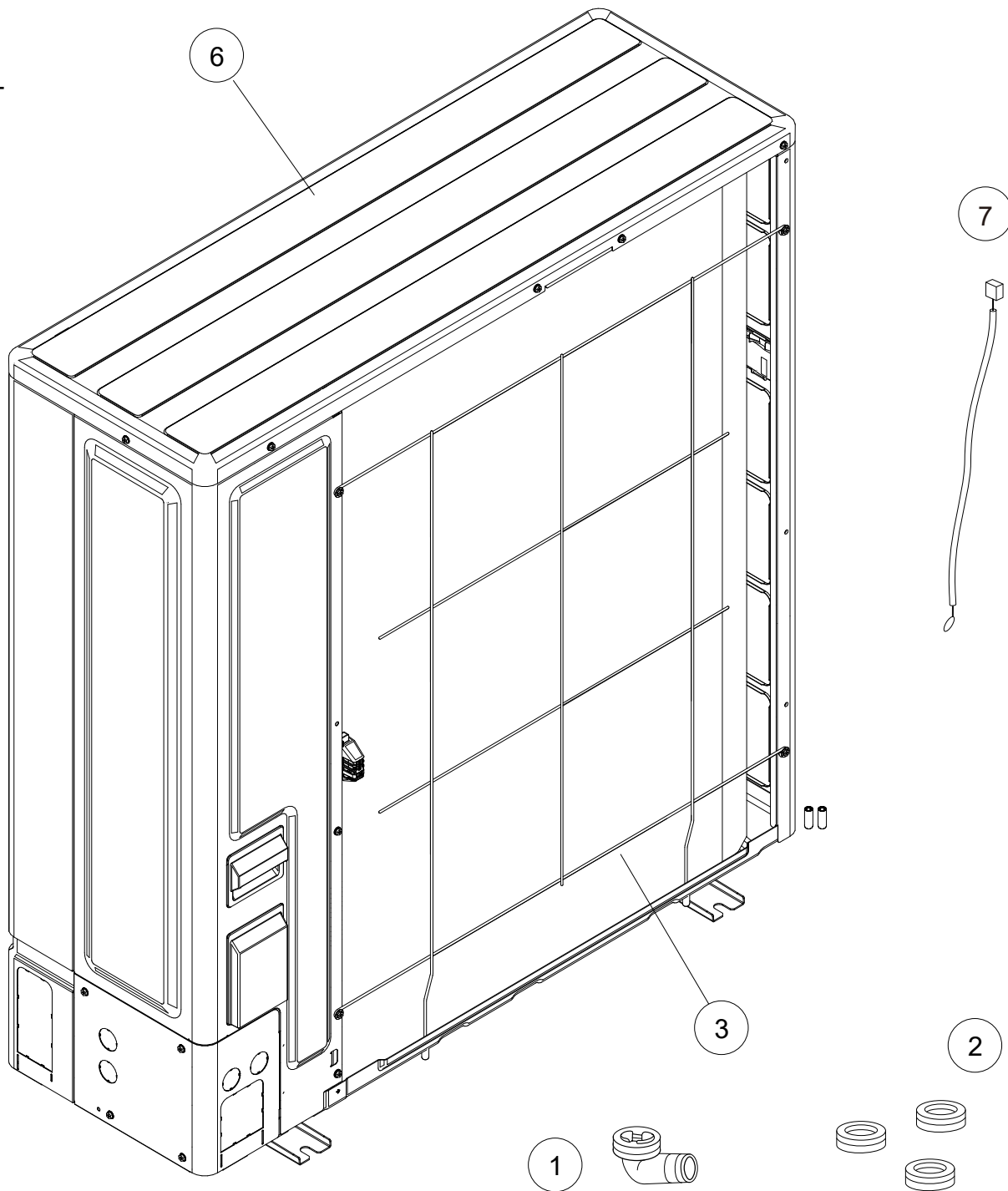

Ref.	Description	Parts number
1	Drain assy	9303029015
2	Drain cap	313166024302
3	Protective net rear	9381013005
4	Rubber (net)	9375361013
5	Thermo holder	9383607004
6	Top panel sub assy	9383880001
7	Outdoor Thermistor	9900565091

OUTDOOR UNIT
AOYG45KBTB

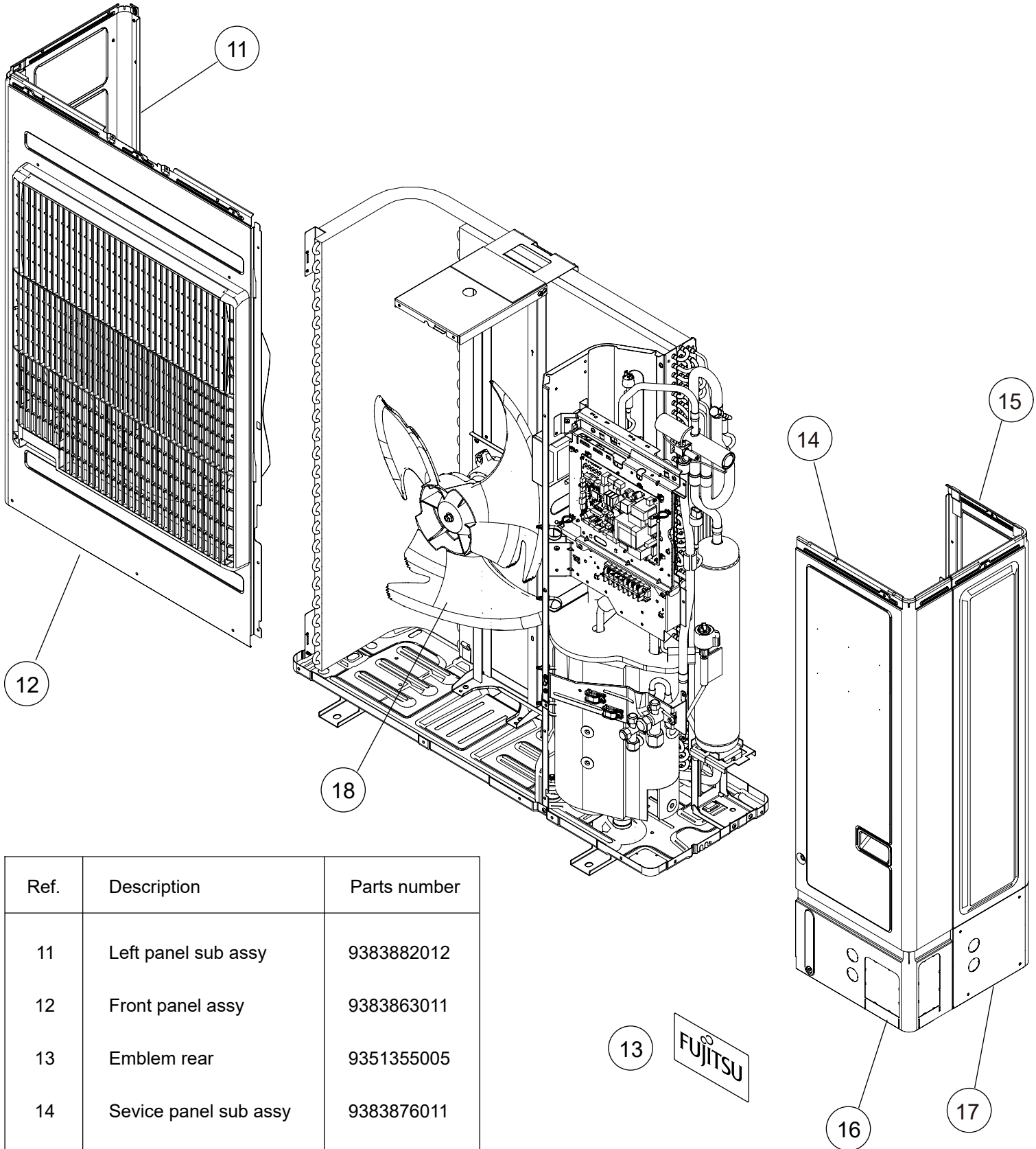

Ref.	Description	Parts number
11	Left panel sub assy	9383882012
12	Front panel assy	9383863011
13	Emblem rear	9351355005
14	Sevice panel sub assy	9383876011
15	Right panel sub assy	9383874017
16	Pipe cover front	9383878008
17	Pipe cover rear	9383879005
18	Propeller fan	9383336003

OUTDOOR UNIT
AOYG45KBTB

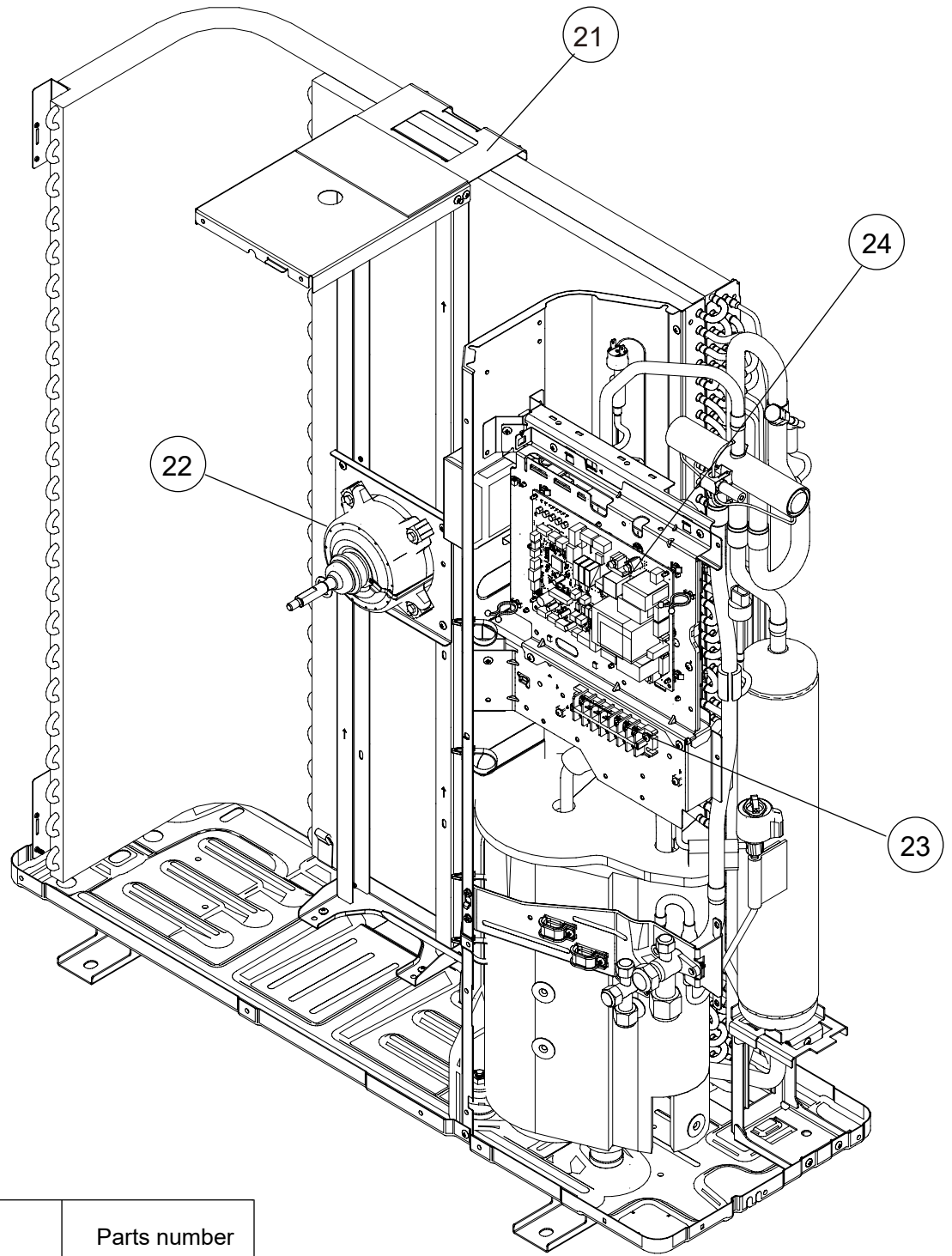

Ref.	Description	Parts number
21	Motor bracket assy	9383862014
22	Motor, DC Brushless	9603733018
23	Terminal 7P	9900203061
24	Main PCB (Service)	9711431028
25	Inverter PCB	9711233011
--	Heat ex. thermistor	9900984038
--	Thermistor assy	9900727154
--	Compressor thermistor	9900985028

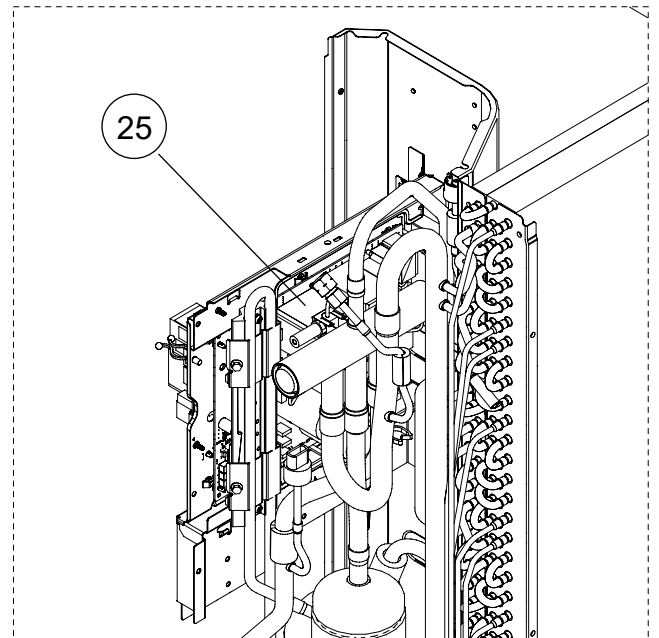

OUTDOOR UNIT
AOYG45KBTB

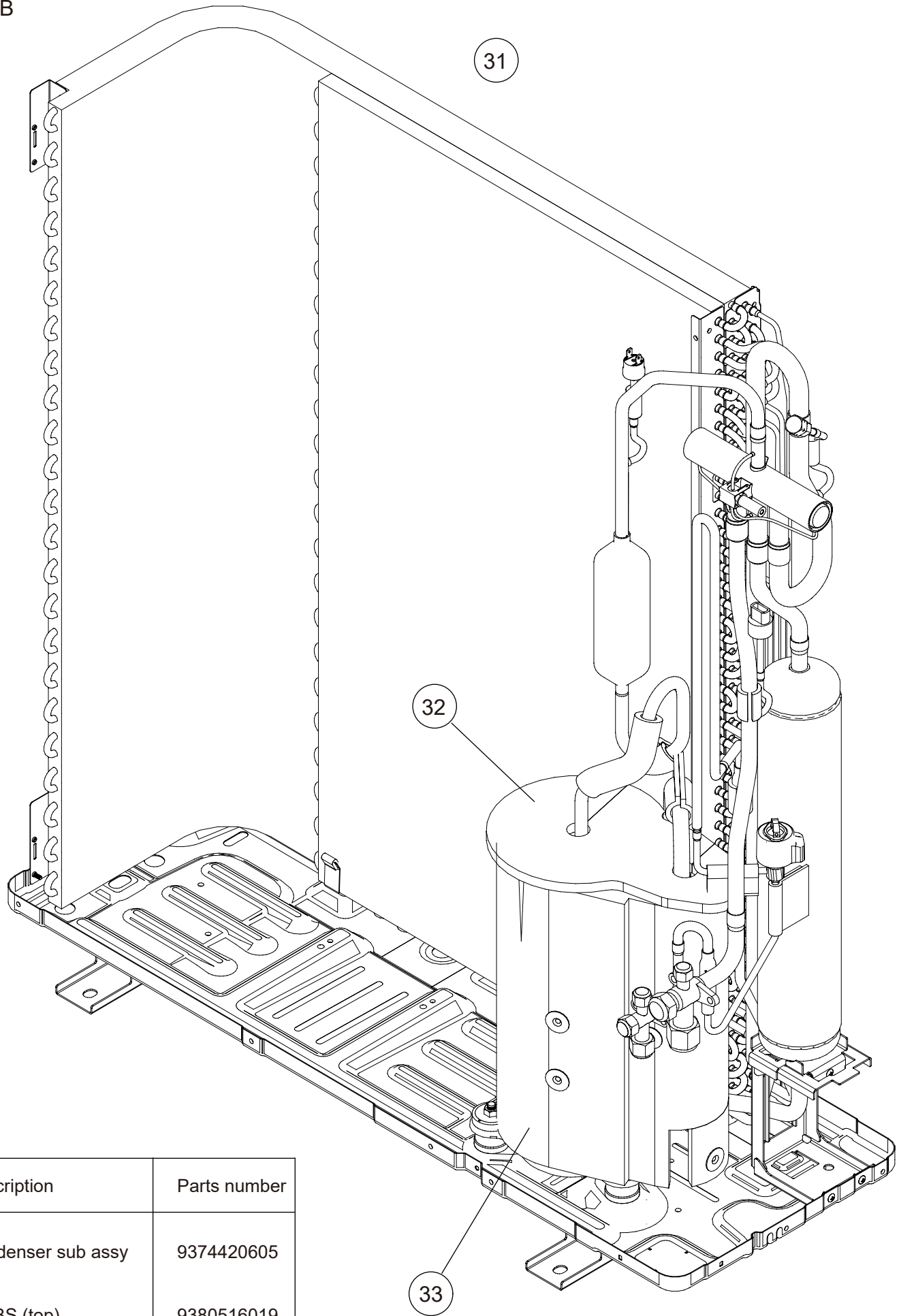

Ref.	Description	Parts number
31	Condenser sub assy	9374420605
32	S-ABS (top)	9380516019
33	S-ABS (body)	9379647168





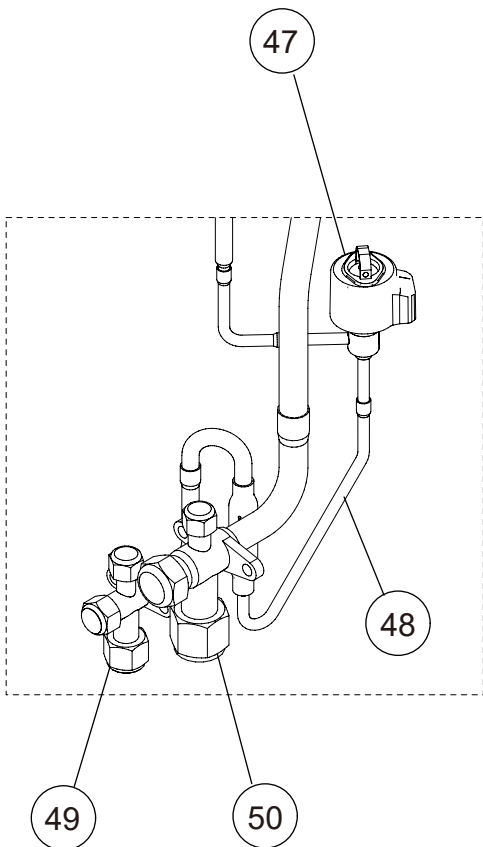
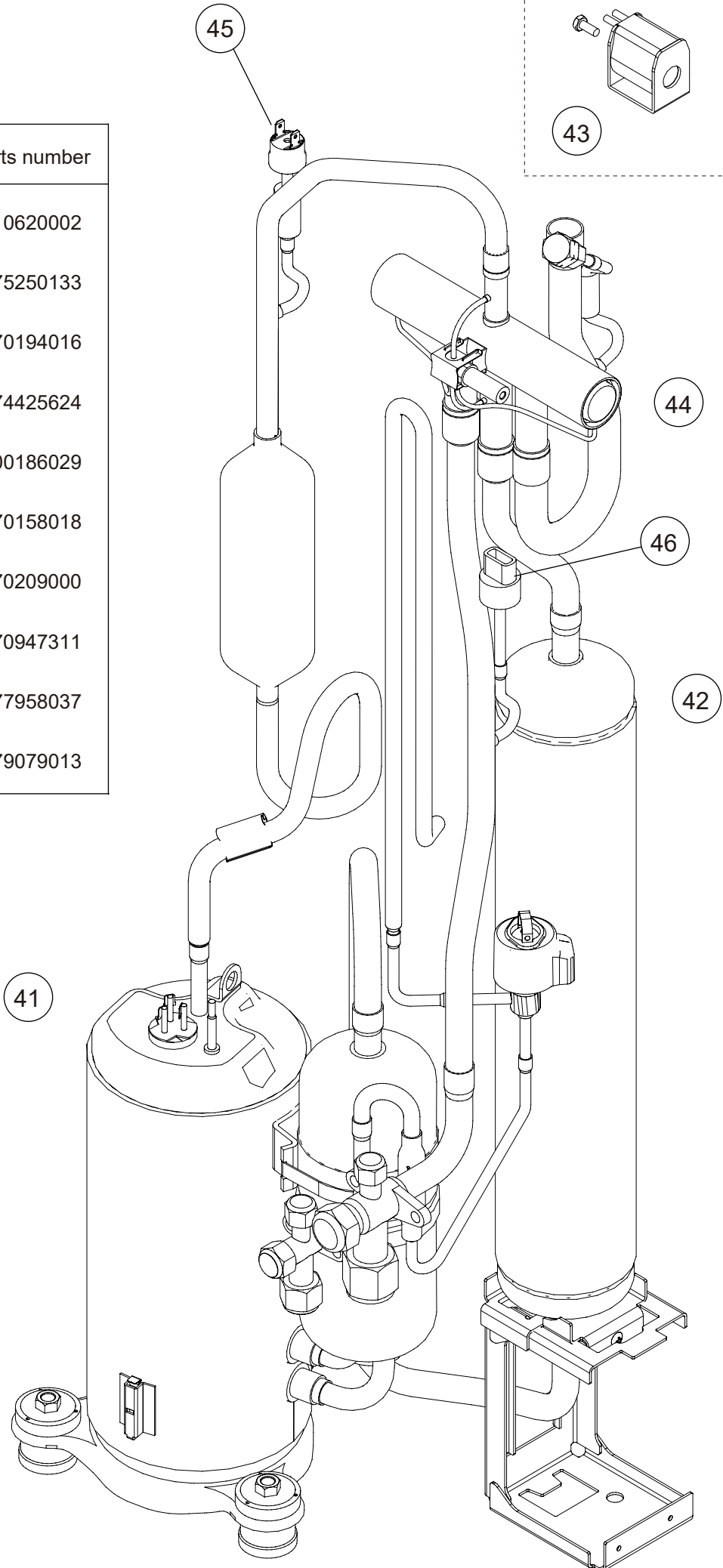



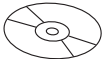

OUTDOOR UNIT
AOYG45KBTB

Ref.	Description	Parts number
41	Compressor	9810620002
42	Accumulator assy	9375250133
43	Solenoid	9970194016
44	4-way valve assy	9374425624
45	pressure switch	9900186029
46	Sensor	9970158018
47	Expansion valve coil	9970209000
48	Expansion valve assy	9370947311
49	3-way valve assy	9377958037
50	3-way valve assy	9379079013

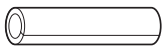

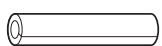
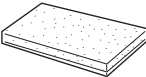



Accessories

Models: ARXG24KMLA, ARXG30KMLA, ARXG36KMLA, and ARXG45KMLA

Part name	Exterior	Q'ty	Part name	Exterior	Q'ty
Operating manual		1	Cable tie (medium)		1
Operating manual (CD-ROM)		1	Cable tie (small)		1
Installation manual		1	Coupler heat insulation (large)		1
Hanger		4	Coupler heat insulation (small)		1
Drain hose insulation		1	M10 nut A (with flange)		4
Cable tie (large)		1	M10 nut B (with spring lock washer)		4

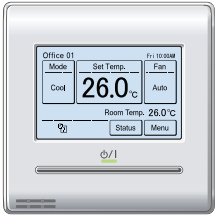
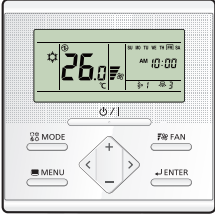
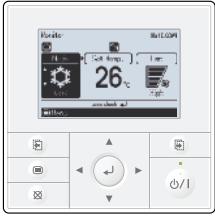
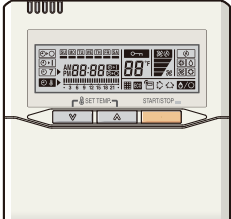
Optional parts

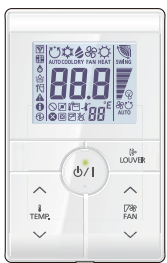

1. Controllers

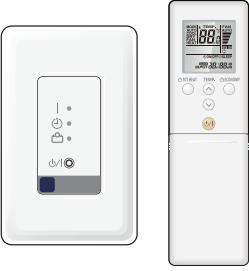

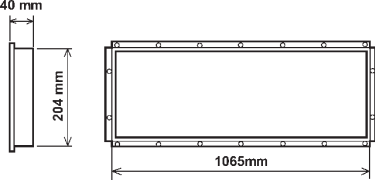
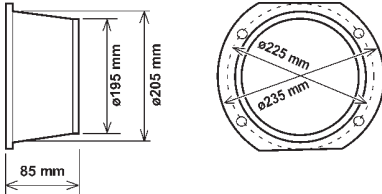

Exterior	Part name	Model name	Summary
	Wired remote controller	UTY-RNRYZ*	Easy finger touch operation with LCD panel. Backlit LCD enables easy operation in a dark room. Wire type: Non-polar 2-wire
	Wired remote controller	UTY-RLRY	High visibility and easy operation. Room temperature can be accurately controlled using the built-in thermo sensor. Wire type: Non-polar 2-wire
	Wired remote controller	UTY-RVNYM	Large and full-dot liquid crystal screen, wide and large keys easy to press, user-intuitive arrow key. Wire type: Polar 3-wire
	Wired remote controller	UTY-RNNYM	Room temperature can be controlled by detecting the temperature accurately with built-in thermo sensor. Wire type: Polar 3-wire
	Simple remote controller	UTY-RSRY	Compact remote controller concentrates on the basic functions such as Start/Stop, fan control, temperature setting, and operation mode. Wire type: Non-polar 2-wire
	Simple remote controller	UTY-RHRY	Compact remote controller concentrates on the basic functions such as Start/Stop, fan control, and temperature setting. Wire type: Non-polar 2-wire
	Simple remote controller	UTY-RSNYM	Compact remote controller concentrates on the basic functions such as Start/Stop, fan control, temperature setting, and operation mode. Wire type: Polar 3-wire

Exterior	Part name	Model name	Summary
	IR receiver kit with wireless remote controller	UTY-LBTYM	Unit control is performed by wireless remote controller.

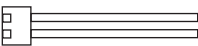
NOTE: Available functions may differ by the remote controller. For details, refer to the operation manual.

2. Others

Exterior	Part name	Model name	Summary
	Remote sensor unit	UTY-XSZX	Thermo-sensor for sensing the temperature of arbitrary place in the room.
	Square flange	UTD-SF045T	Both the Square flange and the Round flange can be selected.
	Round flange	UTD-RF204	Round flange is used when the fresh-air duct is installed.
	Long-life filter	UTD-LF25NA	Long-life filter can be mounted to the indoor unit.
	Drain pump unit	UTZ-PX1NBA	Optional drain lift up mechanism allows more flexible installation.
	External connect kit	UTY-XWZXZG	Use to connect with various peripheral devices and air conditioner PCB. For control output port.



Exterior	Part name	Model name	Summary
	Wireless LAN adapter	UTY-TFSXZ1	Remotely manage an air conditioning system using mobile devices such as smartphones and tablets. For connection indoor unit with UART interface.
	Modbus converter	UTY-VMSX	For connection between indoor unit with UART interface and a Modbus open network.
	KNX converter	UTY-VKSX	For connection between indoor unit with UART interface and a KNX open network.
	External switch controller	UTY-TERX	Air conditioner switching can be controlled by connecting other external sensor switches.

NOTE: Combined use of following optional parts and Wireless LAN adapter (UTY-TFSXZ1) is not allowed.





- Modbus converter
- KNX converter

Accessories

Model: AOYG24KBTB

Part name	Exterior	Q'ty	Part name	Exterior	Q'ty
Installation manual		1	Drain pipe		1

Models: AOYG30KBTB, AOYG36KBTB, and AOYG45KBTB

Part name	Exterior	Q'ty	Part name	Exterior	Q'ty
Installation manual		1	Drain cap		3
Drain pipe		1	One-touch bush		2

Optional parts

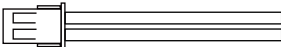
Exterior	Part name	Model name	Summary
	External connect kit	UTY-XWZXZ3	Use to operate the external input and output functions of outdoor unit. (For 30-45 models)

1903G4805