

## SERVICE MANUAL



### CONTENTS

SPECIFICATIONS . . . . .	1
DIMENSIONS . . . . .	7
REFRIGERANT SYSTEM DIAGRAM . . .	12
CIRCUIT DIAGRAM . . . . .	14
PCB CIRCUIT DIAGRAM . . . . .	17
ERROR DETECTION . . . . .	22
PARTS (OUTDOOR UNIT) . . . . .	24
PARTS (INDOOR UNIT) . . . . .	28
ACCESSORIES . . . . .	49

Outdoor unit	Indoor unit
AOYG36LBTB	ABYG18LVTB
UTP-SX236A	ARYG18LLTB
	AUYG18LVLB
	UTG-UFYD-W
AOYG45LBTB	ABYG22LVTA
UTP-SX254A	ARYG22LMLA
	AUYG22LVLA
	UTG-UFYD-W
AOYG54LBTB	ABYG18LVTB
UTP-SX254A	ABYG24LVTA
UTP-SX354A	ARYG18LLTB
	ARYG24LMLA
	AUYG18LVLB
	AUYG24LVLA
	UTG-UFYD-W

# SPECIFICATIONS

## ELECTRICAL DATA

Model name		AOYG36LBTB ABYG18LVTV x 2	AOYG36LBTB ARYG18LLTB x 2	AOYG36LBTB AUYG18LVLB x 2
Power supply		Single phase 230V 50Hz		
Cooling	Capacity	10.0 kW	10.0 kW	10.0 kW
	Power consumption	2.89 kW	2.86 kW	2.89 kW
	EER	3.46 kW/kW	3.50 kW/kW	3.46 kW/kW
	Rated operating current	12.8 A	12.7 A	12.8 A
	Max operating current	19.0 A	19.0 A	19.0 A
Heating	Capacity	11.2 kW	11.2 kW	11.2 kW
	Power consumption	3.06 kW	2.89 kW	3.06 kW
	COP	3.66 kW/kW	3.87 kW/kW	3.66 kW/kW
	Rated operating current	13.6 A	12.8 A	13.6 A
	Max operating current	19.0 A	19.0 A	19.0 A

Model name		AOYG45LBTB ABYG22LVTA x 2	AOYG45LBTB ARYG22LMLA x 2	AOYG45LBTB AUYG22LVLA x 2
Power supply		Single phase 230V 50Hz		
Cooling	Capacity	12.1 kW	12.1 kW	12.1 kW
	Power consumption	3.77 kW	3.70 kW	3.77 kW
	EER	3.21 kW/kW	3.27 kW/kW	3.21 kW/kW
	Rated operating current	16.7 A	16.4 A	16.7 A
	Max operating current	20.4 A	20.4 A	20.4 A
Heating	Capacity	14.0 kW	14.0 kW	14.0 kW
	Power consumption	3.97 kW	3.93 kW	3.97 kW
	COP	3.52 kW/kW	3.56 kW/kW	3.52 kW/kW
	Rated operating current	17.6 A	17.4 A	17.6 A
	Max operating current	20.4 A	20.4 A	20.4 A

## ELECTRICAL DATA

Model name		AOYG54LBTB ABYG24LVTA x 2	AOYG54LBTB ABYG18LVTB x 3	AOYG54LBTB ARYG24LMLA x 2	AOYG54LBTB ARYG18LLTB x 3	AOYG54LBTB AUYG24LVLA x 2	AOYG54LBTB AUYG18LVLB x 3
Power supply		Single phase 230V 50Hz					
Cooling	Capacity	13.3 kW	13.3 kW	13.3 kW	13.3 kW	13.3 kW	13.3 kW
	Power consumption	4.40 kW	4.23 kW	4.40 kW	4.14 kW	4.40 kW	4.23 kW
	EER	3.02 kW/kW	3.14 kW/kW	3.02 kW/kW	3.21 kW/kW	3.02 kW/kW	3.14 kW/kW
	Rated operating current	19.5 A	18.8 A	19.5 A	18.4 A	19.5 A	18.8 A
	Max operating current	21.5 A	21.5 A	21.5 A	21.5 A	21.5 A	21.5 A
Heating	Capacity	15.0 kW	16.0 kW	15.0 kW	16.0 kW	15.0 kW	16.0 kW
	Power consumption	4.48 kW	4.53 kW	4.40 kW	4.34 kW	4.48 kW	4.53 kW
	COP	3.35 kW/kW	3.53 kW/kW	3.41 kW/kW	3.68 kW/kW	3.35 kW/kW	3.53 kW/kW
	Rated operating current	19.9 A	20.1 A	19.5 A	19.3 A	19.9 A	20.1 A
	Max operating current	21.5 A	21.5 A	21.5 A	21.5 A	21.5 A	21.5 A

## OUTDOOR UNIT

### FAN MOTOR AND FAN REVOLUTION

Model name		AOYG36LBTB	AOYG45LBTB	AOYG54LBTB
Connection			AB AU	AR
Discrimination		MFE-45VVT		
Cooling	Upper fan	780 rpm	850 rpm	900 rpm
	Lower fan	750 rpm	800 rpm	800 rpm
Heating	Upper fan	780 rpm	780	850
	Lower fan	750 rpm	750	830

### AIR CIRCULATION

Cooling	6,200 m3/h	6,750 m3/h	6,850 m3/h
Heating	6,200 m3/h	6,200	6,750

### NOISE LEVEL

Cooling	52 dB	54 dB	55 dB
Heating	54 dB	55 dB	56 dB

### COMPRESSOR AND REFRIGERANT

Type	Hermetic type, Inverter, 4 poles, DC motor, Twin Rotary		
Discrimination*	A	DA422A3F-28ZAD	
	B	DA422A3T-20ZA	
Weight (with oil)	A	23.0 kg	
	B	23.3 kg	
Refrigerant type	R410A		
Precharged refrigerant	3,450 g		
Total pipe length	30 m	3,450 g	
	45 m	4,200 g	
	60 m	4,950 g	
	75 m	5,700 g	
Additional charge	50 g/m		

\*B is interchangeable with A.

### MEASUREMENT

Dimensions H x W x D	1,290 x 900 x 330 mm
Weight Net / Shipping	93 kg / 102 kg



INDOOR UNIT  
CEILING TYPE

FAN MOTOR AND FAN REVOLUTION

Model name		ABYG18LVTB	ABYG22LVTA	ABYG24LVTA
Discrimination		MFH-24RVL		
Cooling	High	1,040 rpm	1,330 rpm	
	Medium	950 rpm	1,150 rpm	
	Low	800 rpm	1,000 rpm	
	Quiet	740 rpm	780 rpm	
Heating	High	1,040 rpm	1,300 rpm	
	Medium	950 rpm	1,150 rpm	
	Low	800 rpm	1,000 rpm	
	Quiet	740 rpm	780 rpm	

AIR CIRCULATION

Ventilation	High	780 m3/h	980 m3/h	
	Medium	700 m3/h	820 m3/h	
	Low	560 m3/h	680 m3/h	
	Quiet	500 m3/h	540 m3/h	

NOISE LEVEL

Cooling	High	43 dB	48 dB	
	Medium	40 dB	44 dB	
	Low	34 dB	40 dB	
Heating	Quiet	31 dB	35 dB	
	High	43 dB	48 dB	
	Medium	40 dB	44 dB	
	Low	34 dB	40 dB	
Heating	Quiet	31 dB	35 dB	

MEASUREMENT

DIMENSIONS	H x W x D	199 x 990 x 655 mm	
WEIGHT	Net / Shipping	27 kg / 36 kg	

INDOOR UNIT  
DUCT TYPE

FAN MOTOR AND FAN REVOLUTION

Model name		ARYG18LLTB	ARYG22LMLA	ARYG24LMLA
Discrimination		MFG-24WVAL	MFG-24RVAL	
Cooling	High	1,380 rpm	830 rpm	
	Medium	1,300 rpm	700 rpm	
	Low	1,220 rpm	600 rpm	
	Quiet	1,140 rpm	550 rpm	
Heating	High	1,380 rpm	830 rpm	
	Medium	1,300 rpm	700 rpm	
	Low	1,220 rpm	600 rpm	
	Quiet	1,140 rpm	550 rpm	

AIR CIRCULATION

Ventilation	High	940 m3/h	1,100 m3/h
	Medium	880 m3/h	910 m3/h
	Low	820 m3/h	750 m3/h
	Quiet	750 m3/h	580 m3/h

NOISE LEVEL

Cooling	High	32 dB	31 dB
	Medium	30 dB	29 dB
	Low	29 dB	27 dB
Heating	Quiet	27 dB	25 dB
	High	32 dB	31 dB
	Medium	30 dB	29 dB
	Low	29 dB	27 dB

MEASUREMENT

DIMENSIONS	H x W x D	198 x 900 x 620	270 x 1,135 x 700 mm
WEIGHT	Net / Shipping	23 kg / 30 kg	38 kg / 44 kg

INDOOR UNIT  
CASSETTE TYPE

FAN MOTOR AND FAN REVOLUTION

Model name		AUYG18LVLB	AUYG22LVLA	AUYG24LVLA
Discrimination		MFF-24RVL		
Cooling	High	730 rpm	960 rpm	
	Medium	630 rpm	850 rpm	
	Low	540 rpm	650 rpm	
	Quiet	460 rpm	500 rpm	
Heating	High	830 rpm	960 rpm	
	Medium	730 rpm	880 rpm	
	Low	630 rpm	740 rpm	
	Quiet	500 rpm	580 rpm	

AIR CIRCULATION

Ventilation	High	680 m3/h	930 m3/h	
	Medium	580 m3/h	830 m3/h	
	Low	490 m3/h	600 m3/h	
	Quiet	410 m3/h	450 m3/h	

NOISE LEVEL

Cooling	High	38 dB	49 dB	
	Medium	34 dB	44 dB	
	Low	30 dB	36 dB	
Heating	High	43 dB	49 dB	
	Medium	38 dB	45 dB	
	Low	34 dB	40 dB	
	Quiet	30 dB	33 dB	

MEASUREMENT

DIMENSIONS	H x W x D	245 x 570 x 570 mm	
WEIGHT	Net / Shipping	15 kg / 18 kg	16 kg / 19 kg

DECORATION PANL  
MEASUREMENT

DIMENSIONS	H x W x D	49 x 700 x 700 mm	
WEIGHT	Net / Shipping	2.6 kg / 4.5 kg	

# DIMENSIONS

OUTDOOR UNIT

Unit : mm

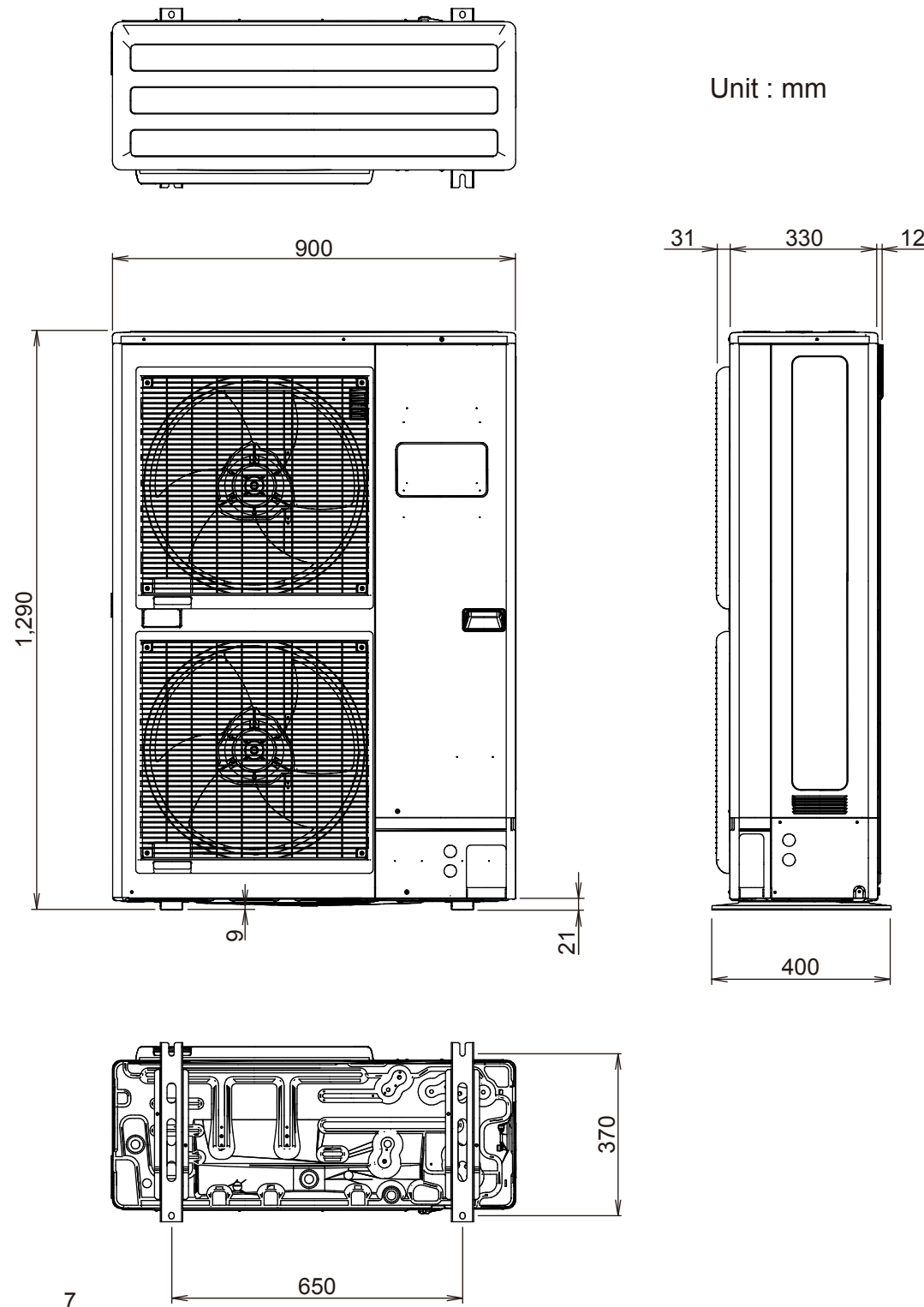

BRANCH PIPE  
(unit : mm)

UTP-SX236A

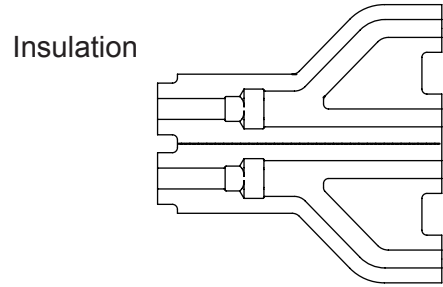
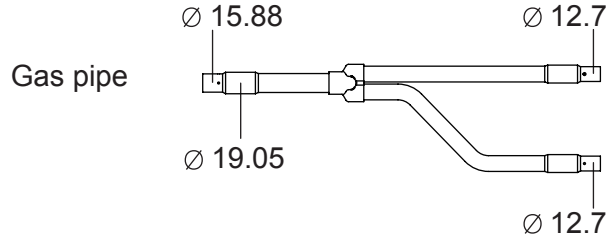

Liquid pipe

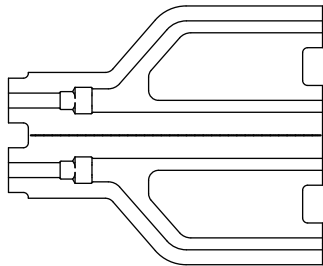
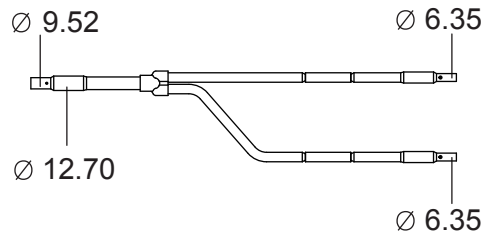

UTP-SX254A

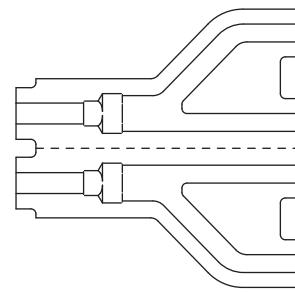
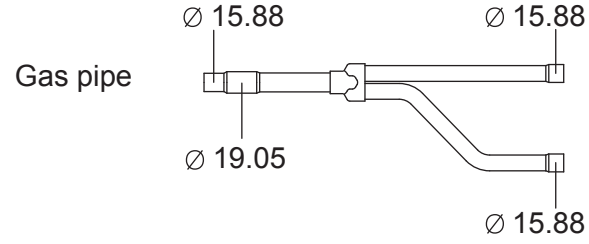

Liquid pipe

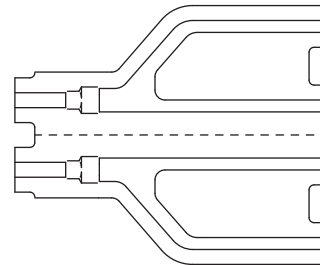
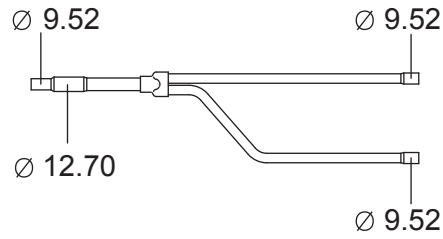

UTP-SX354A

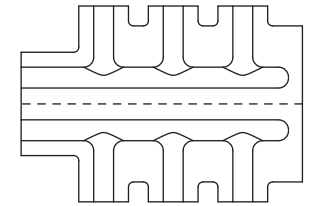
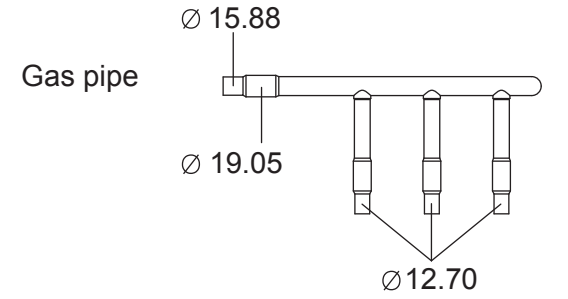

Liquid pipe

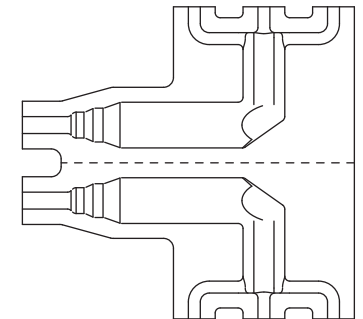
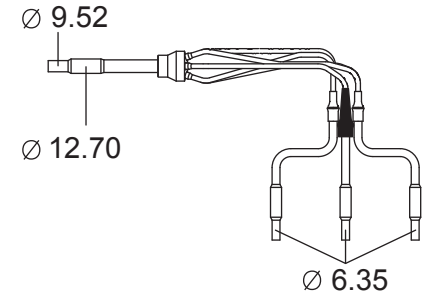

INDOOR UNIT  
CEILING  
ABYG18LVTB  
ABYG22LVTA  
ABYG24LVTA  
Unit : mm

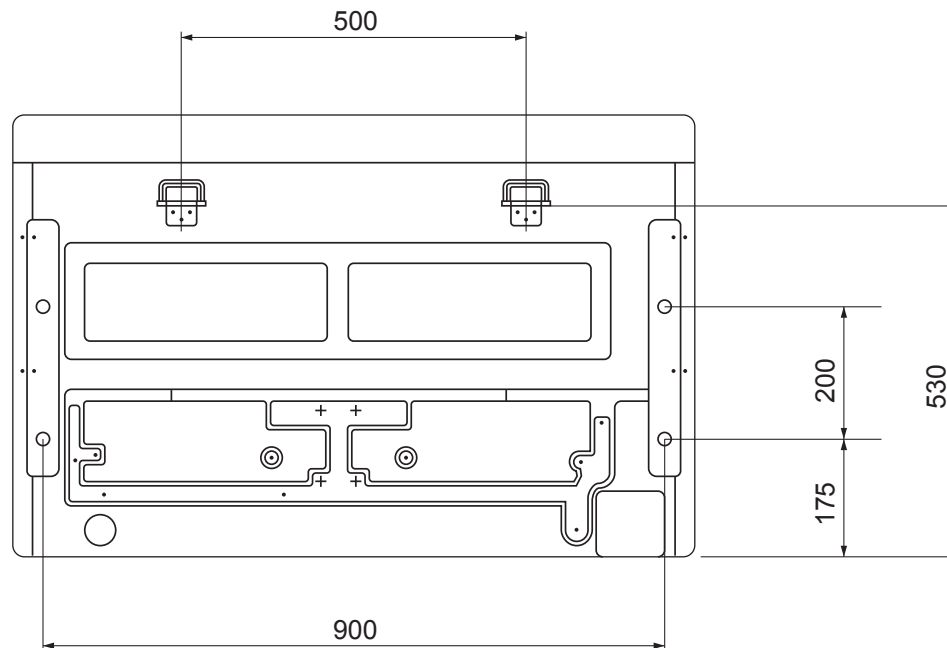
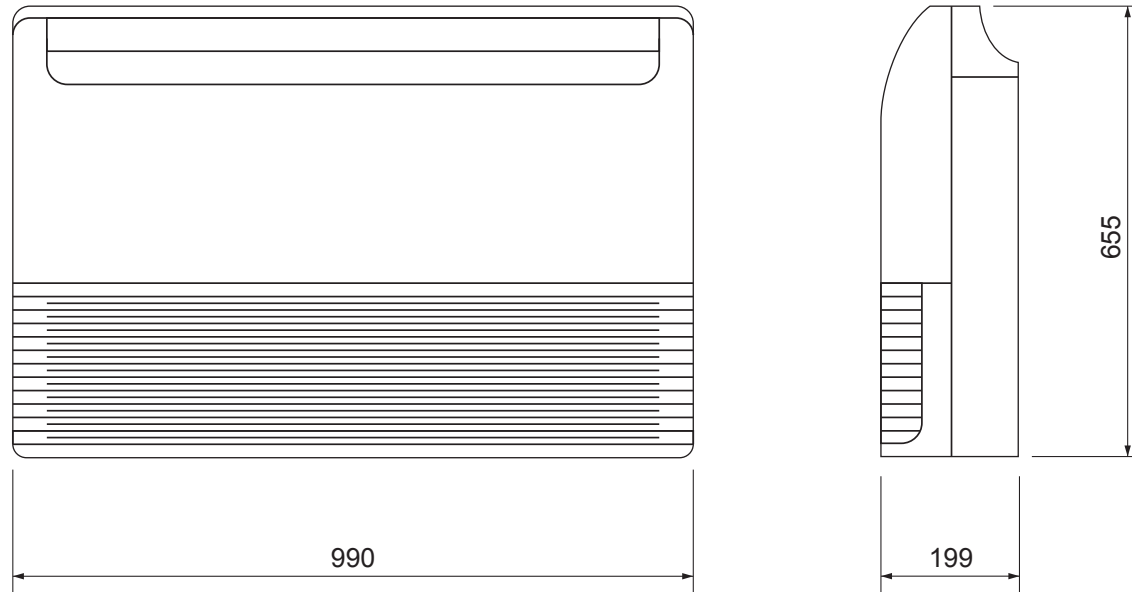

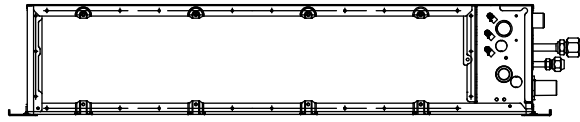

INDOOR UNIT  
SLIM DUCT  
ARYG18LLTB  
Unit : mm

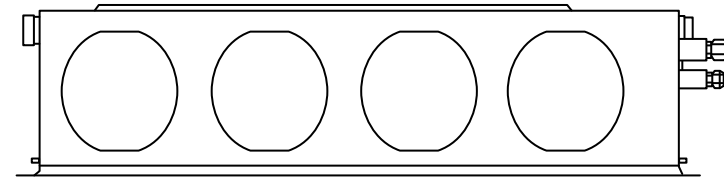

INDOOR UNIT  
DUCT  
ARYG22LMLA  
ARYG24LMLA  
Unit : mm

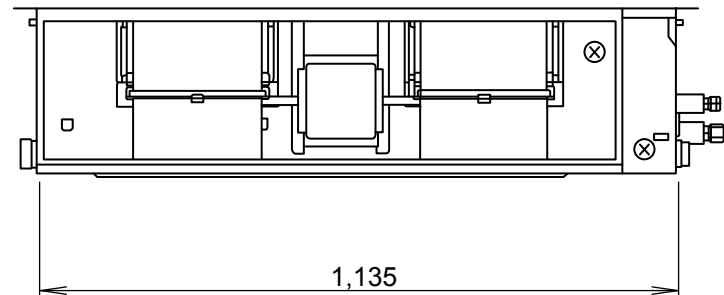
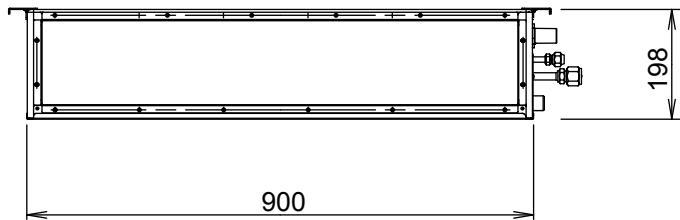
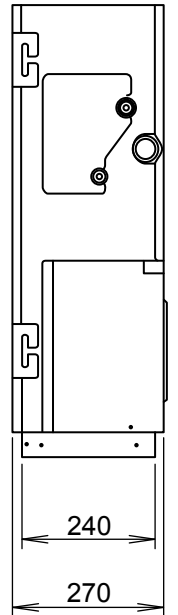
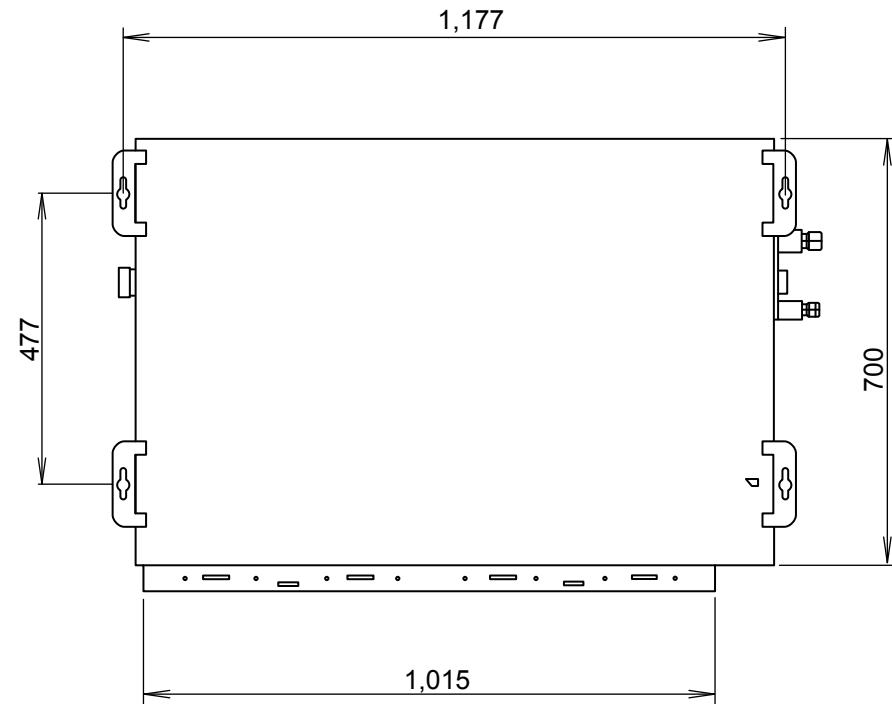
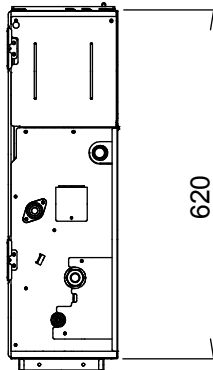
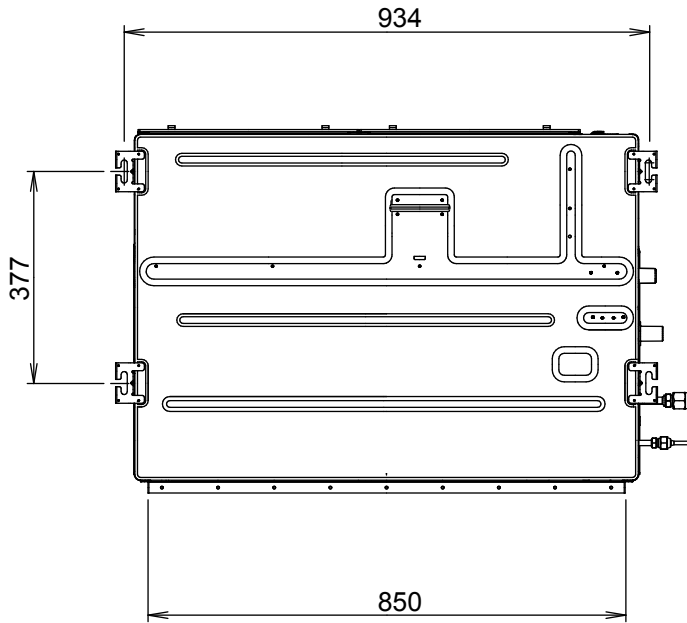

INDOOR UNIT  
CASSETTE  
AUYG18LVLB  
AUYG22LVLA  
AUYG24LVLA  
Unit : mm

INDOOR UNIT

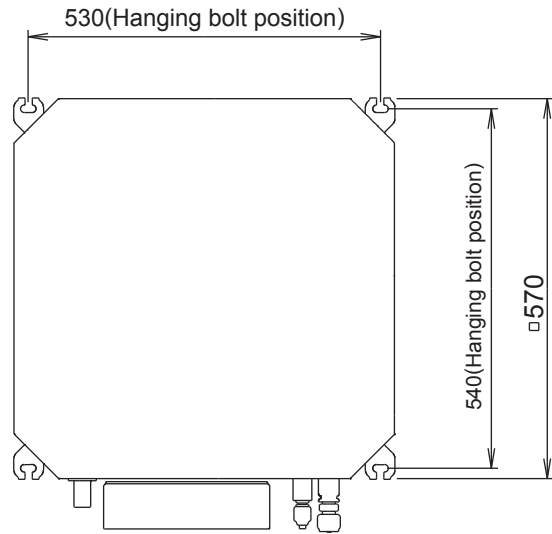

Top view

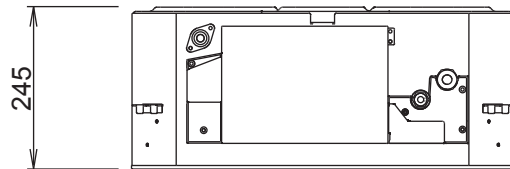

Side view

DECORATION PANEL  
UTG-UFYD-W

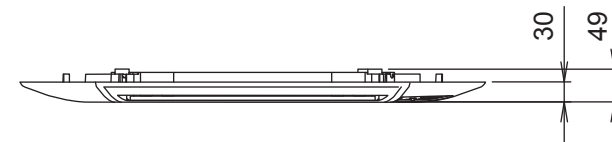
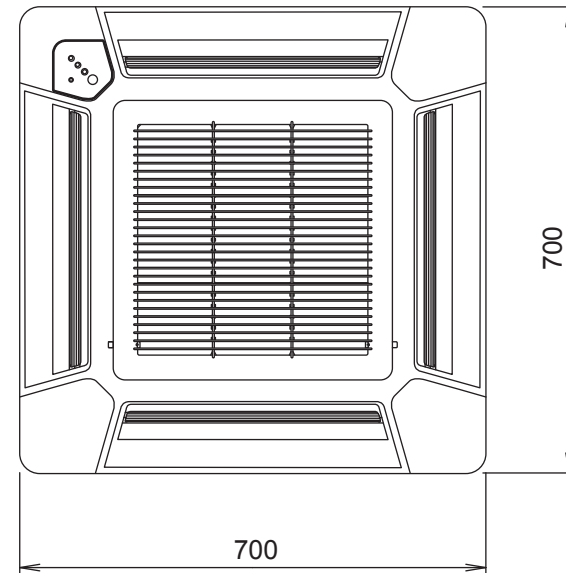



# REFRIGERANT SYSTEM DIAGRAM

Refrigerant flow

—▶ : Cool

---▶ : Heat

OUTDOOR UNIT

INDOOR UNIT

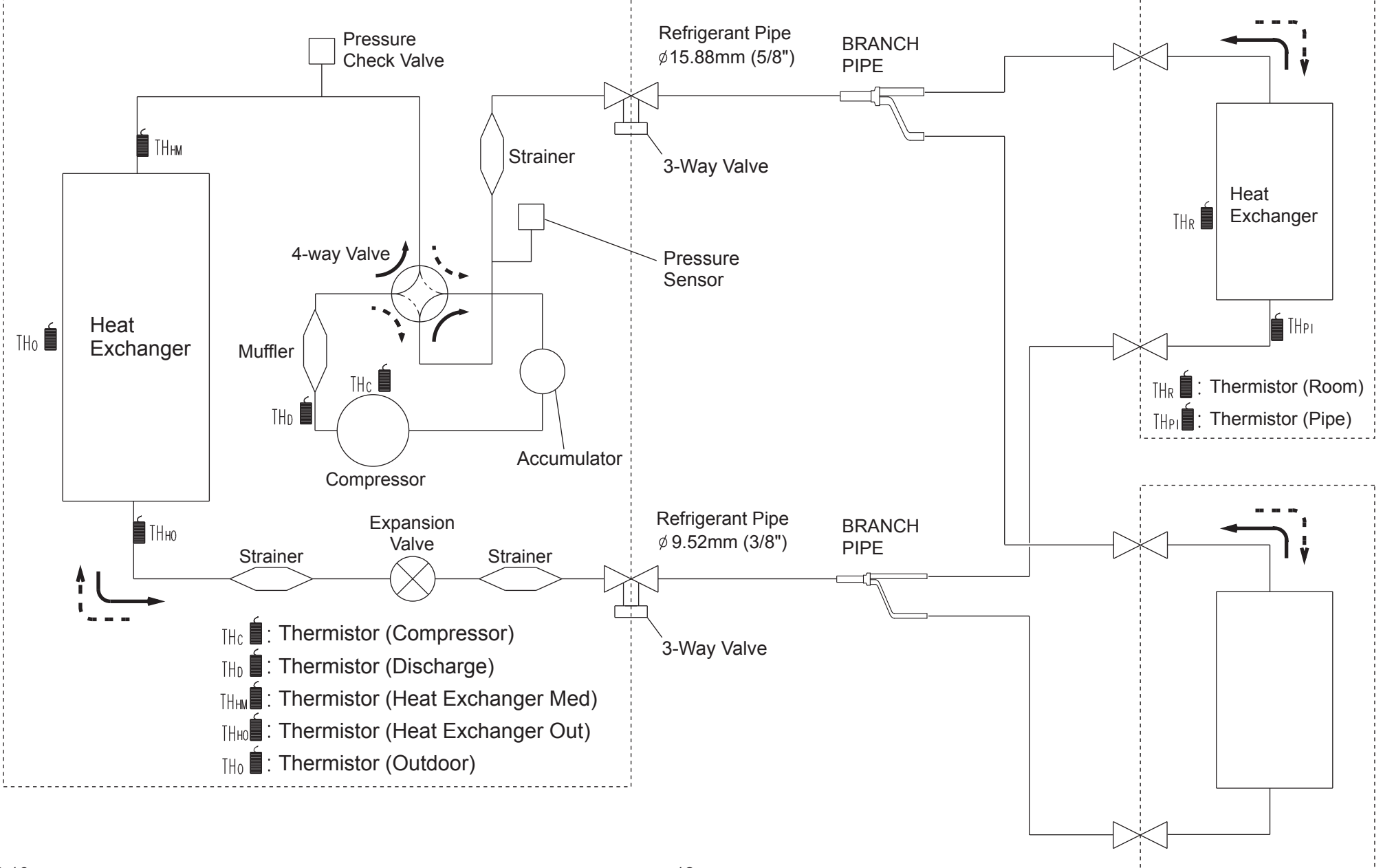

# LIMITATION OF PIPE CONNECTION

Two indoor units

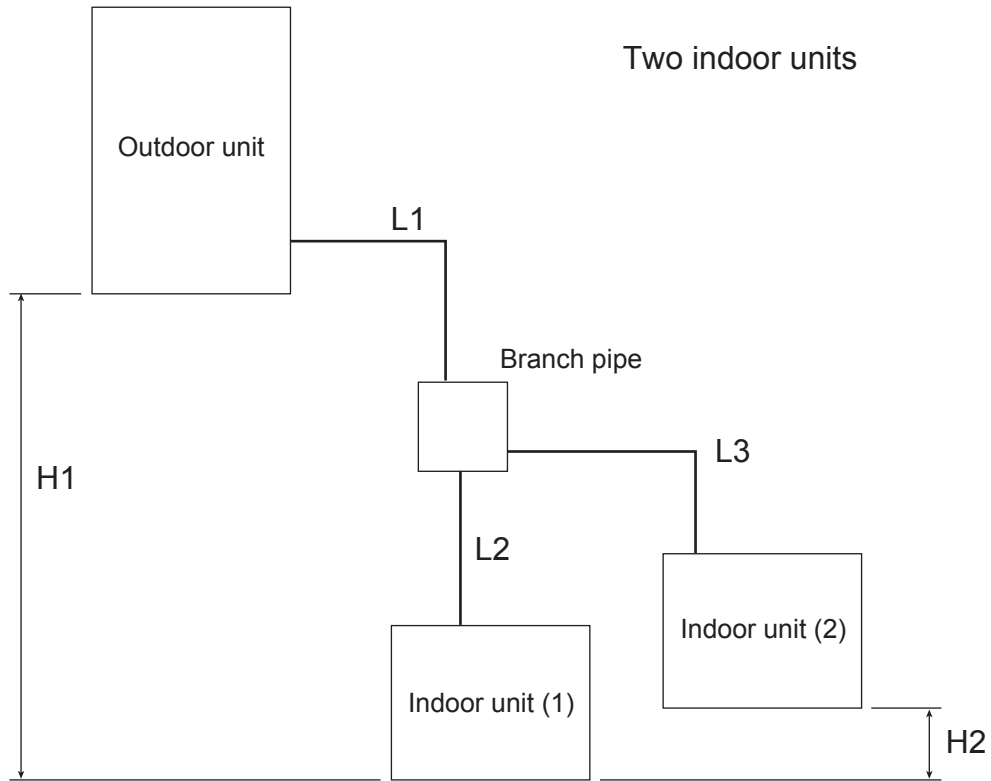

Maximum length of total pipe

$$L1 + L2 + L3 = 75\text{m}$$

Maximum length of branch piping

$$L2 = 20\text{m} \quad L3 = 20\text{m}$$

Maximum height between indoor and outdoor units

$$H1 = 30\text{m}$$

Maximum height between indoor units

$$H2 = 0.5\text{m}$$

Three indoor units

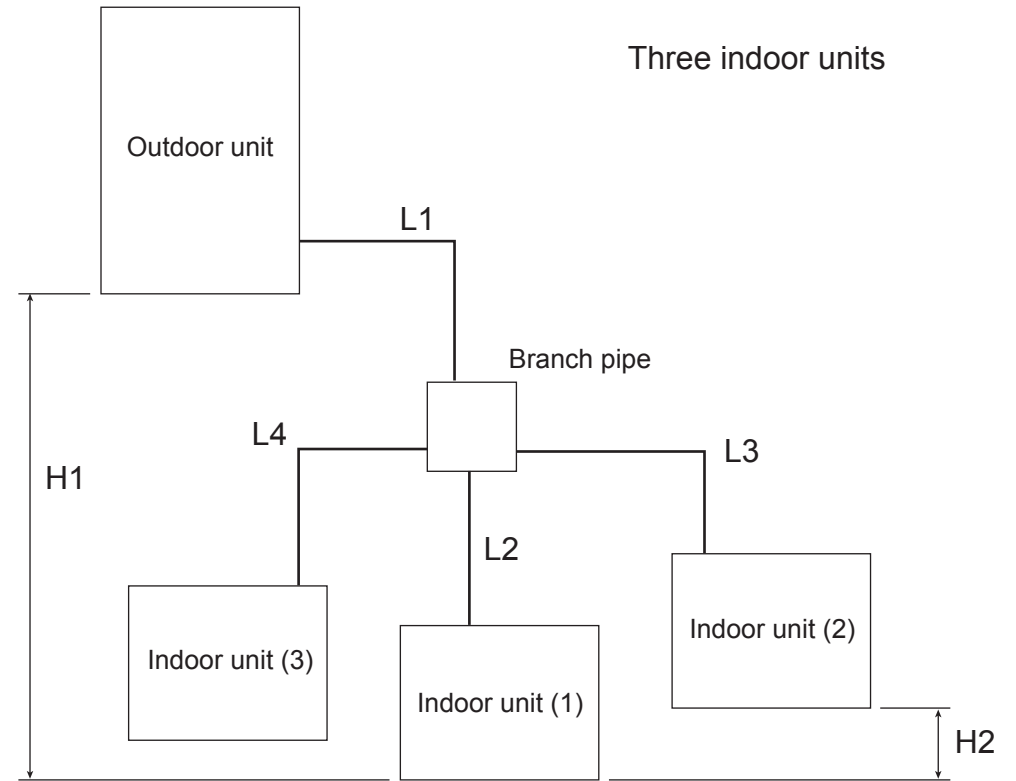

Maximum length of total pipe

$$L1 + L2 + L3 + L4 = 75\text{m}$$

Maximum length of branch piping

$$L2 = 20\text{m} \quad L3 = 20\text{m} \quad L4 = 20\text{m}$$

Maximum height between indoor and outdoor units

$$H1 = 30\text{m}$$

Maximum height between indoor units

$$H2 = 0.5\text{m}$$

# CIRCUIT DIAGRAM

OUTDOOR UNIT  
 AOYG36LBTB  
 AOYG45LBTB  
 AOYG54LBTB

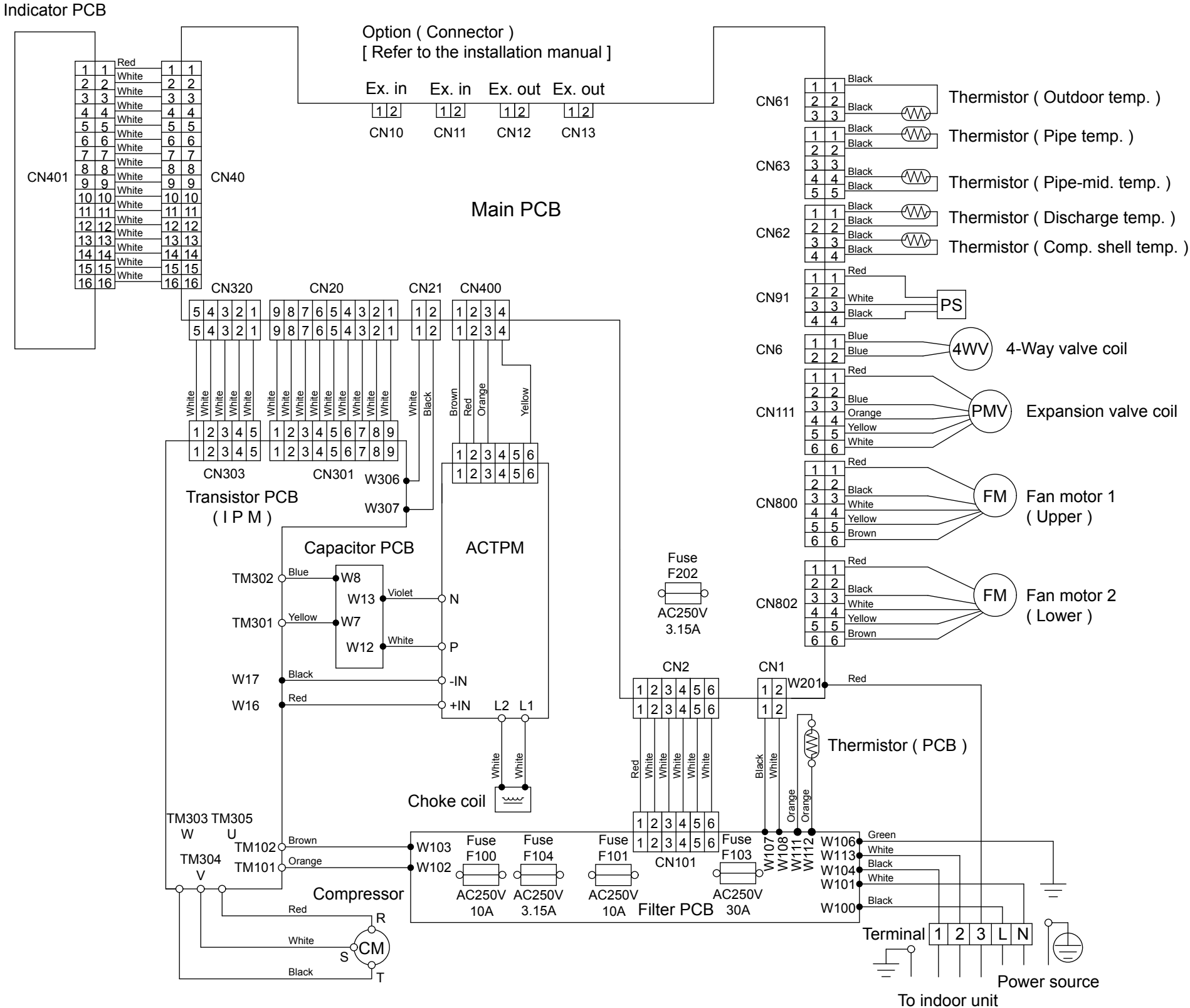

Models : ABYG18LVTB  
 ABYG22LVTA  
 ABYG24LVTA

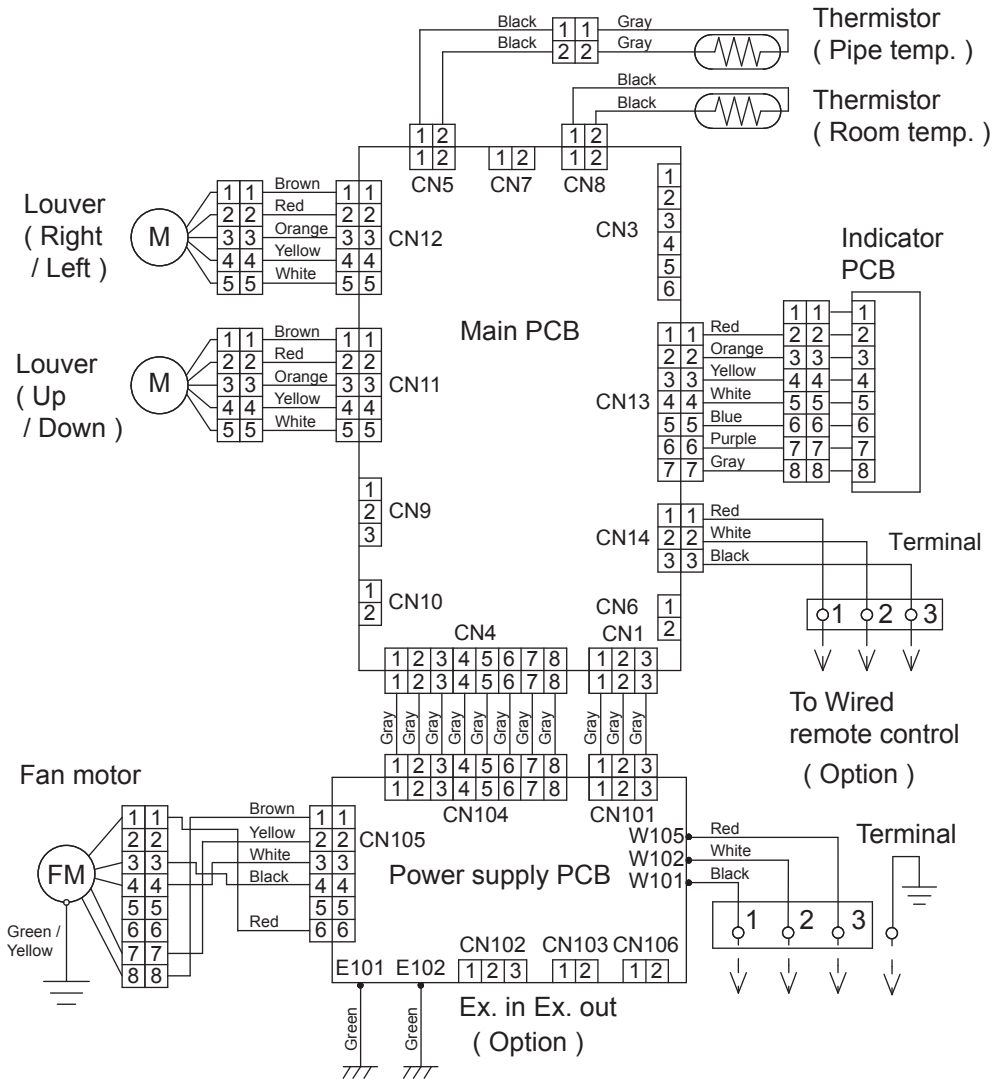

Model : ARYG18LLTB

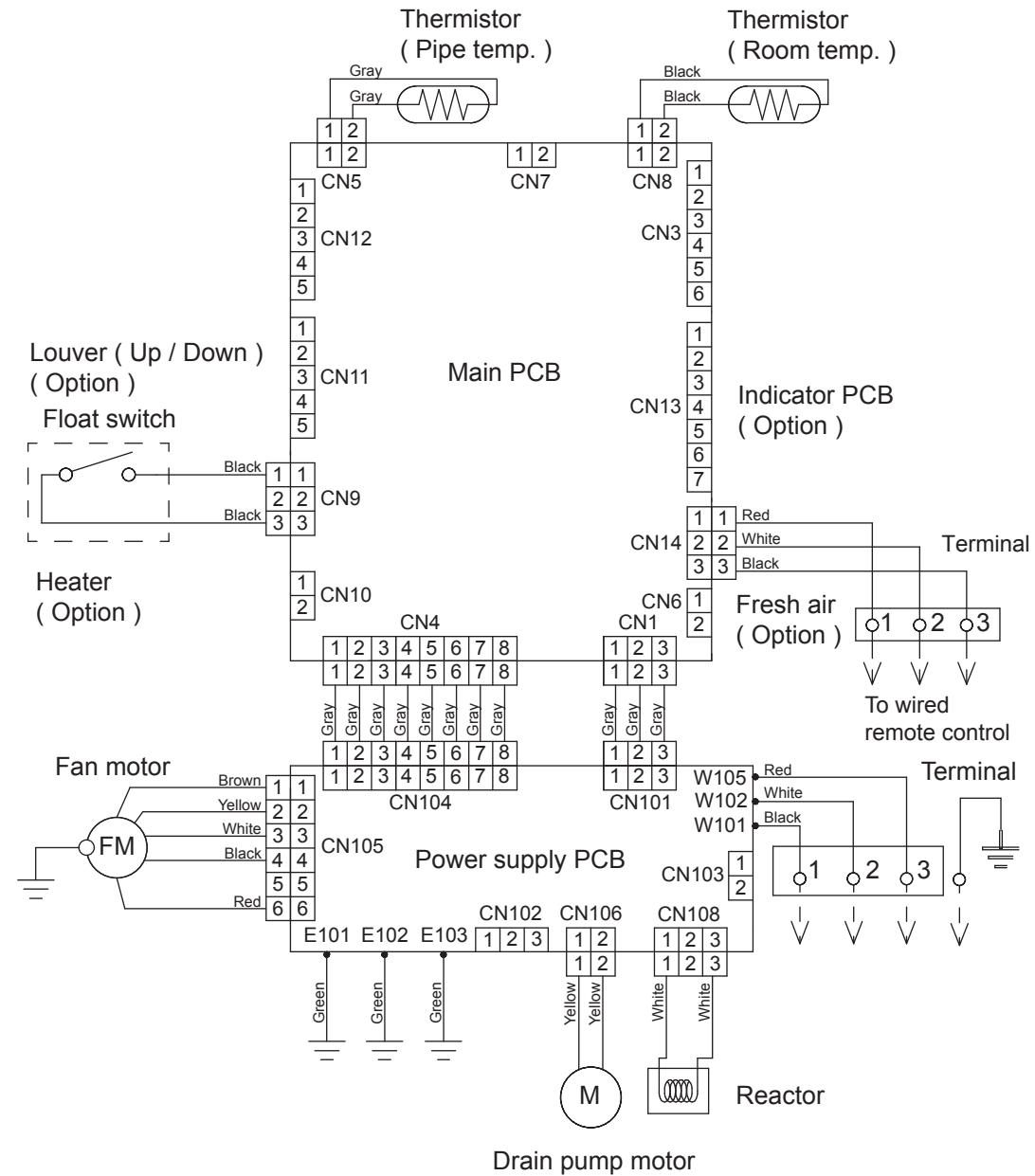

Models : ARYG22LMLA  
ARYG24LMLA

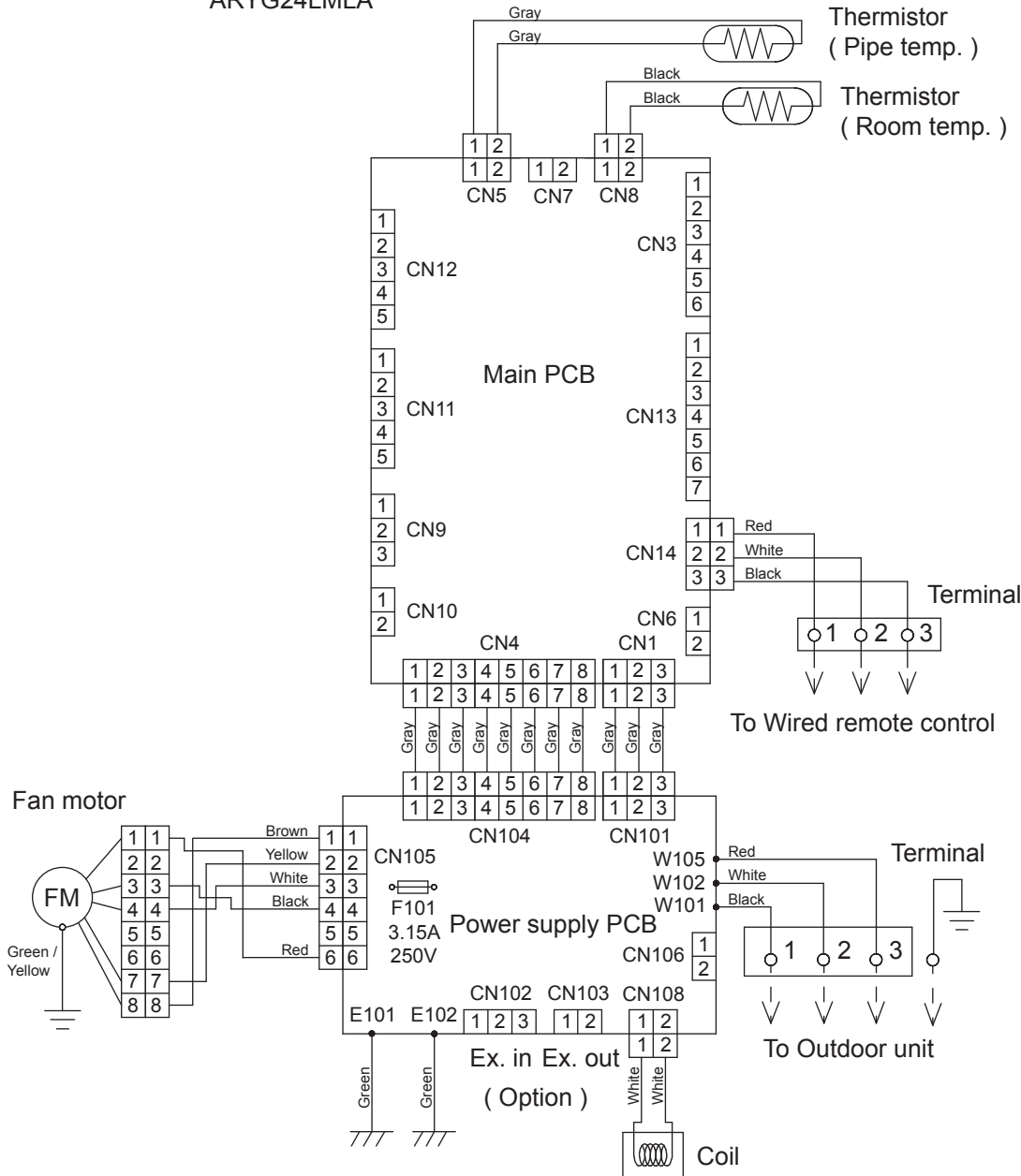

Models : AUYG18LVLB  
AUYG22LVLA  
AUYG24LVLA  
UTG-UFYD-W

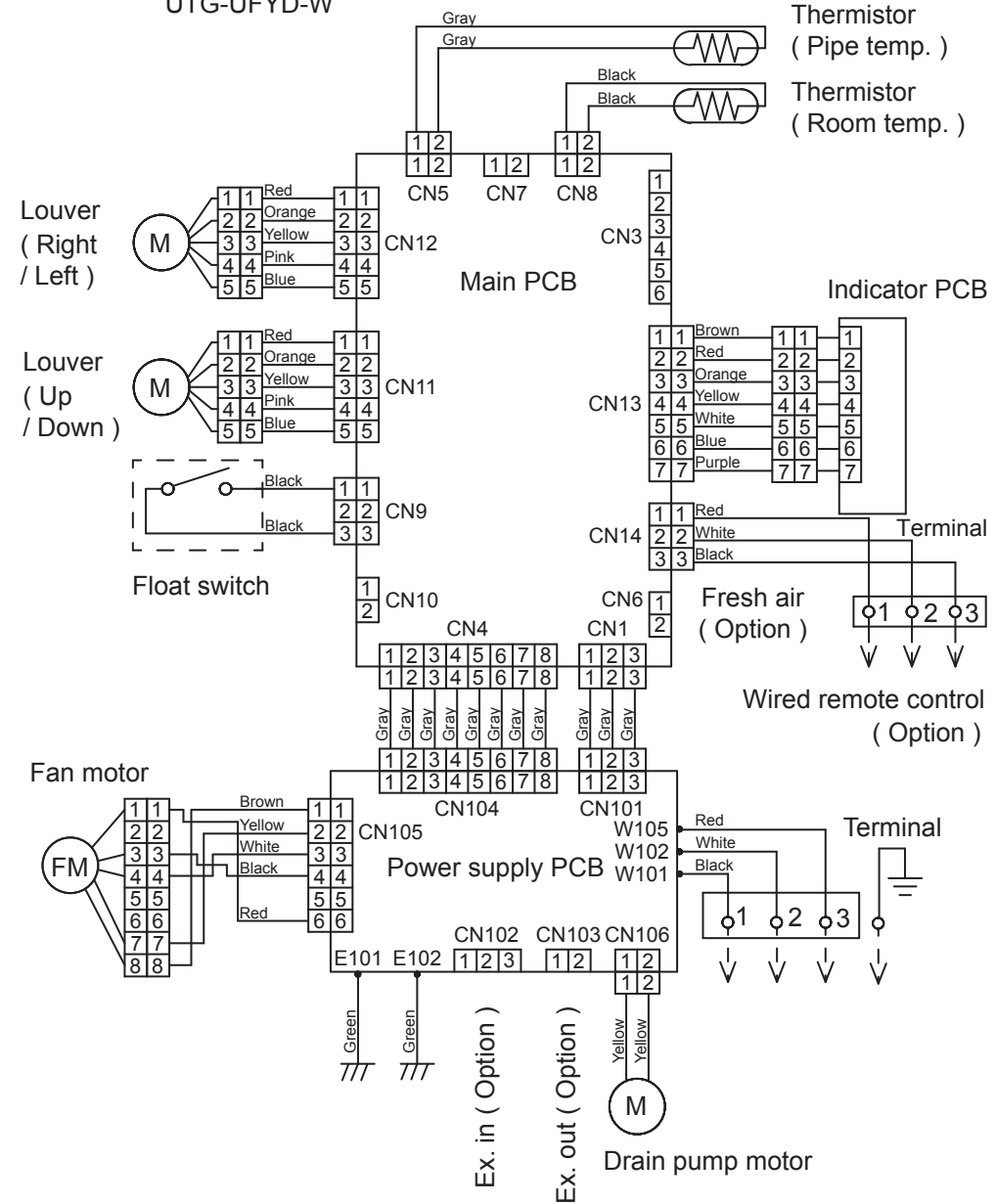

# PCB CIRCUIT DIAGRAM

## OUTDOOR UNIT

## INVERTER ASSEMBLY

AOYG36LBTA : EZ-01508HUE  
 AOYG45LBTA : EZ-01509HUE  
 AOYG54LBTA : EZ-0150AHUE

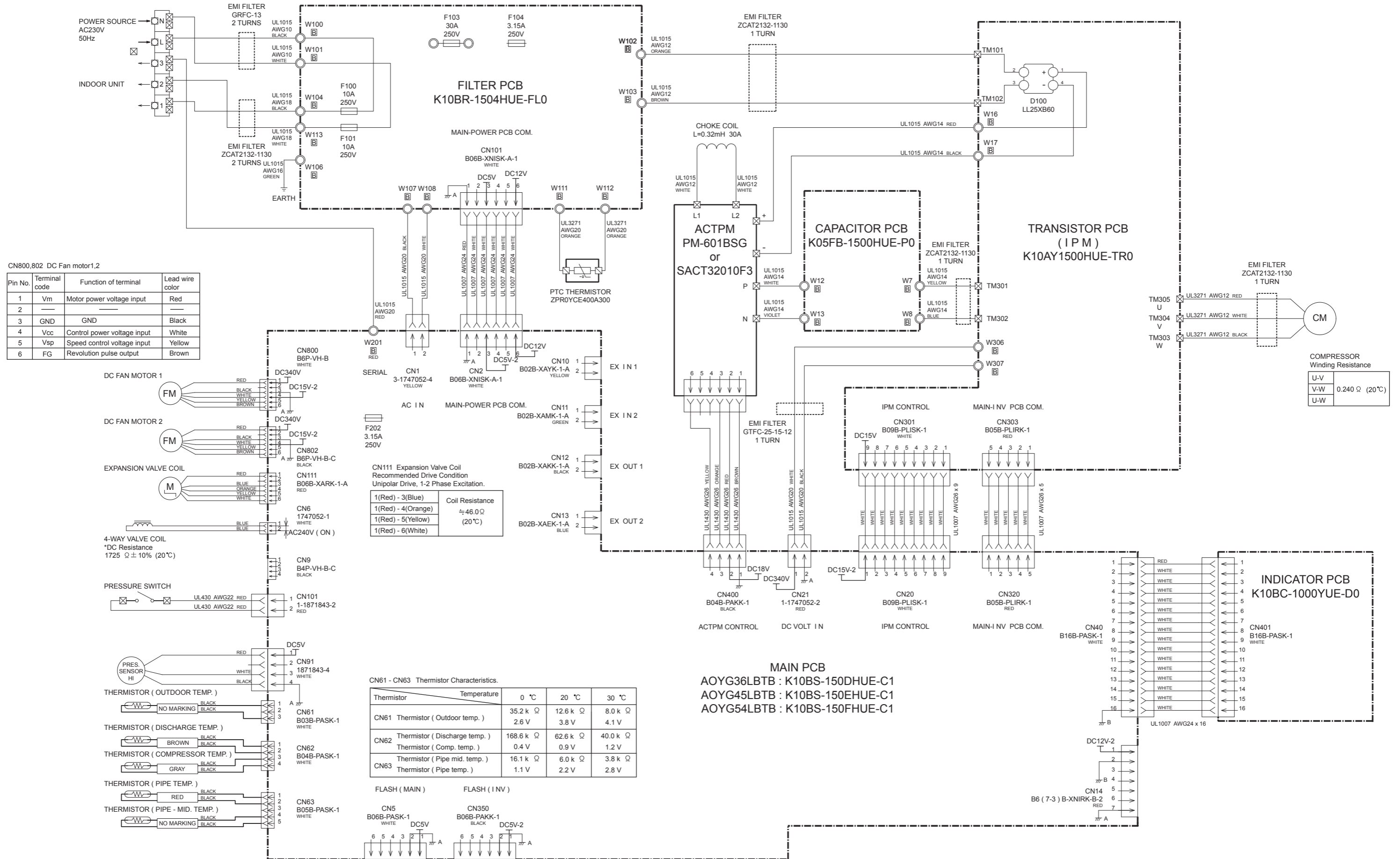

CN800,802 DC Fan motor1,2

Pin No.	Terminal code	Function of terminal	Lead wire color
1	Vm	Motor power voltage input	Red
2			
3	GND	GND	Black
4	Vcc	Control power voltage input	White
5	Vsp	Speed control voltage input	Yellow
6	FG	Revolution pulse output	Brown

CN111 Expansion Valve Coil Recommended Drive Condition Unipolar Drive, 1-2 Phase Excitation.

Coil Resistance	Temperature
1(Red) - 3(Blue)	≈ 46.0 Ω (20°C)
1(Red) - 4(Orange)	
1(Red) - 5(Yellow)	
1(Red) - 6(White)	

CN61 - CN63 Thermistor Characteristics.

Thermistor	Temperature		
	0 °C	20 °C	30 °C
CN61 Thermistor ( Outdoor temp. )	35.2 k Ω	12.6 k Ω	8.0 k Ω
	2.6 V	3.8 V	4.1 V
CN62 Thermistor ( Discharge temp. )	168.6 k Ω	62.6 k Ω	40.0 k Ω
CN62 Thermistor ( Comp. temp. )	0.4 V	0.9 V	1.2 V
CN63 Thermistor ( Pipe mid. temp. )	16.1 k Ω	6.0 k Ω	3.8 k Ω
CN63 Thermistor ( Pipe temp. )	1.1 V	2.2 V	2.8 V

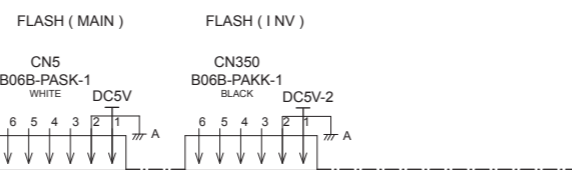

COMPRESSOR Winding Resistance

U-V	0.240 Ω (20°C)
V-W	
U-W	

# INDOOR UNIT CEILING

**CONTROL UNIT**  
 ABYG18LVTB : EZ-0122BHSE  
 ABYG22LVTA : EZ-0122YHSE  
 ABYG24LVTA : EZ-0122CHSE

CN8  
Thermistor Characteristics.

Thermistor	Temperature ( 0°C )	( 20°C )	( 30°C )
Thermistor ( Room temp. )	33.6 k Ω 1.1 V	12.5 k Ω 2.2 V	8.0 k Ω 2.8 V

CN5  
Thermistor Characteristics.

Thermistor	Temperature ( 0°C )	( 20°C )	( 30°C )
Thermistor ( Pipe temp. )	176.0 k Ω 1.1 V	62.9 k Ω 2.2 V	39.6 k Ω 2.8 V

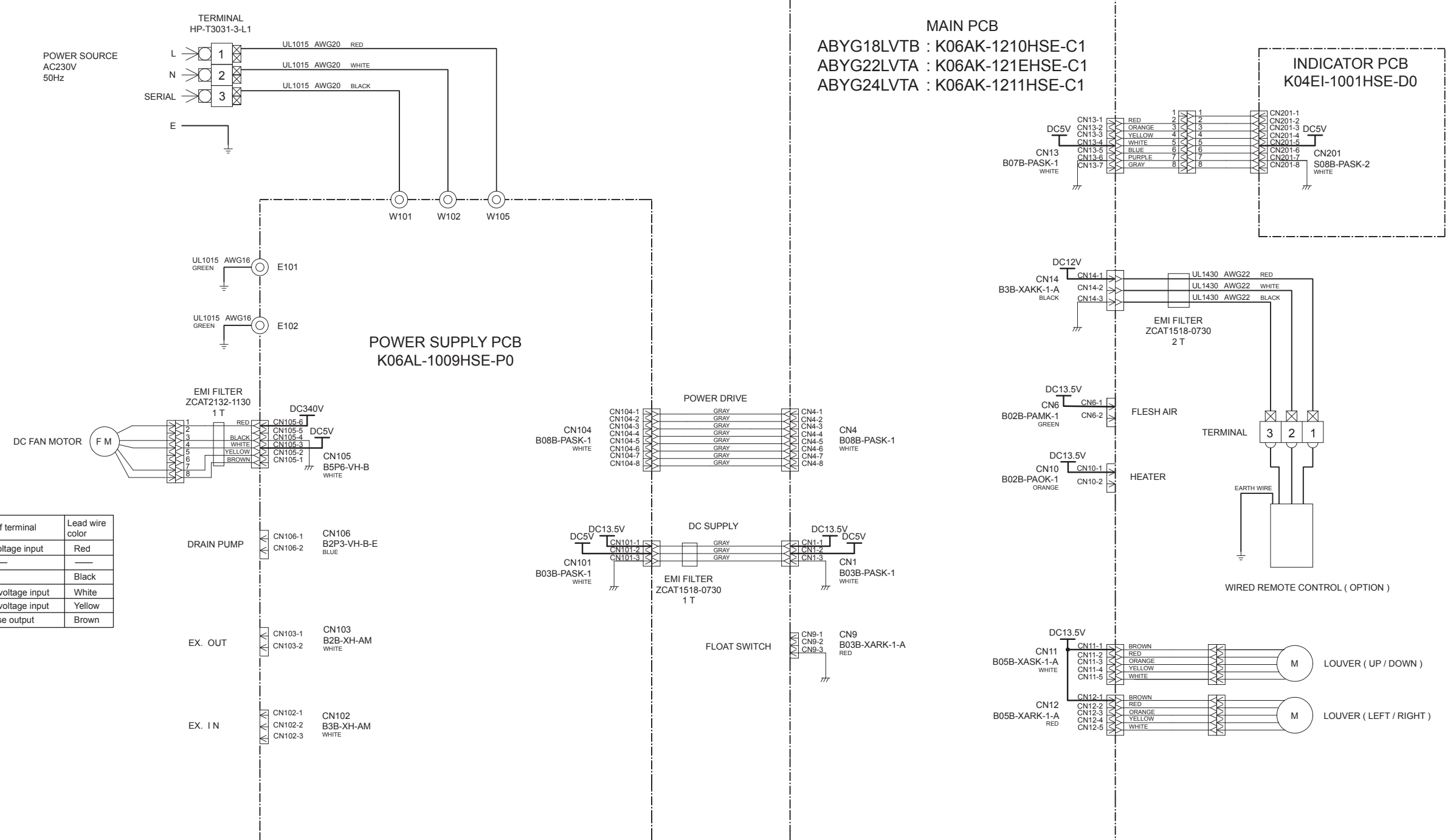

CN105 DC Fan motor

Pin No.	Terminal code	Function of terminal	Lead wire color
6	Vm	Motor power voltage input	Red
5	—	—	—
4	GND	GND	Black
3	Vcc	Control power voltage input	White
2	Vsp	Speed control voltage input	Yellow
1	FG	Revolution pulse output	Brown

INDOOR UNIT  
DUCT  
ARYG18LLTB

CONTROL UNIT  
EZ-01226HSE

CN8 Thermistor Characteristics.

Thermistor	Temperature	0 °C	20 °C	30 °C
Thermistor ( room temp. )		33.6 k Ω	12.5 k Ω	8.0 k Ω
		1.1 V	2.2 V	2.8 V

CN5 Thermistor Characteristics.

Thermistor	Temperature	0 °C	20 °C	30 °C
Thermistor ( Pipe temp. )		176.0 k Ω	62.9 k Ω	39.6 k Ω
		1.1 V	2.2 V	2.8 V

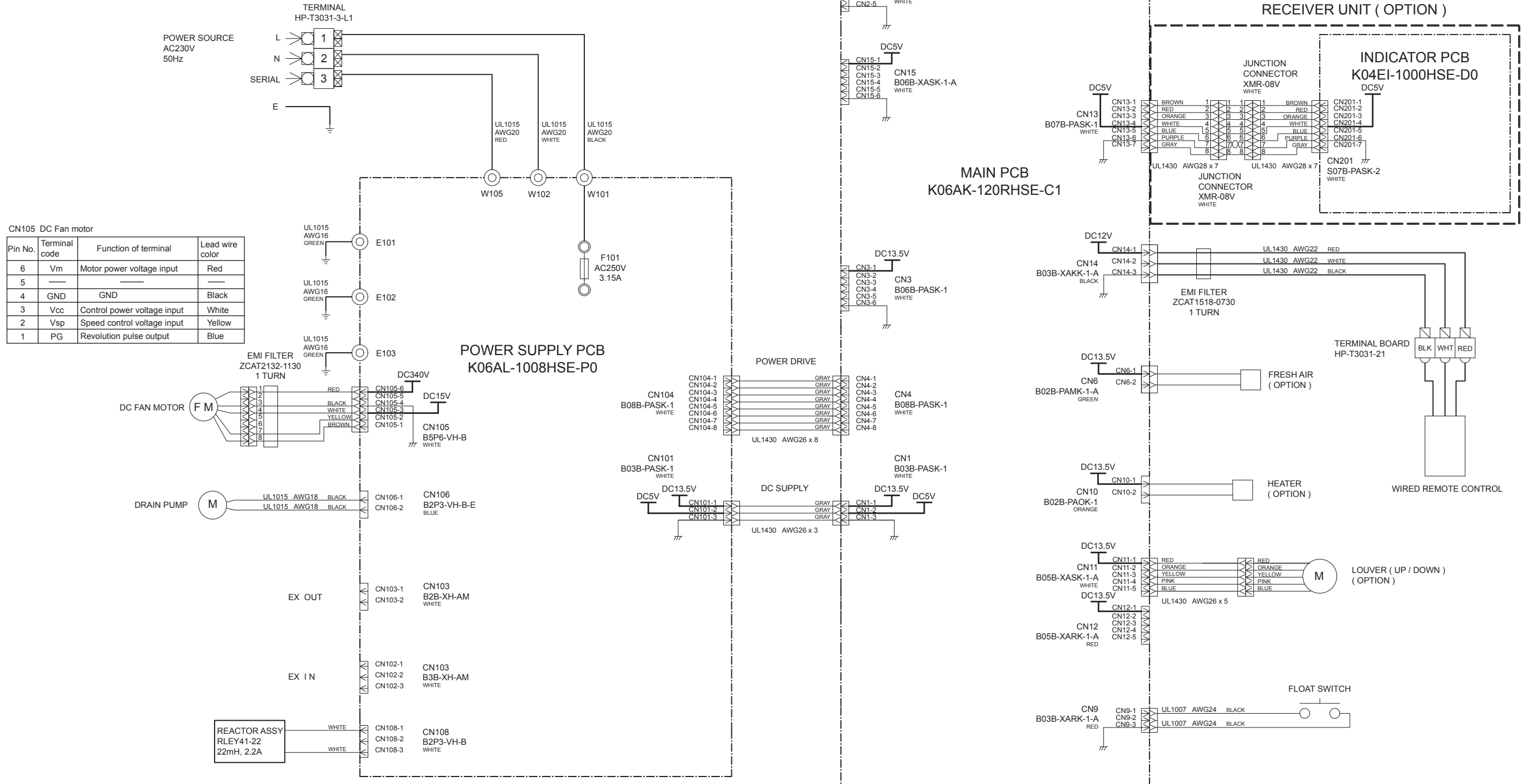

CN105 DC Fan motor

Pin No.	Terminal code	Function of terminal	Lead wire color
6	Vm	Motor power voltage input	Red
5	---	---	---
4	GND	GND	Black
3	Vcc	Control power voltage input	White
2	Vsp	Speed control voltage input	Yellow
1	PG	Revolution pulse output	Blue



# INDOOR UNIT DUCT

**CONTROL UNIT**  
 ARYG22LMLA : EZ-01226HSE  
 ARYG24LMLA : EZ-01227HSE

CN8 Thermistor Characteristics.

Thermistor	Temperature	0 °C	20 °C	30 °C
Thermistor ( room temp. )		33.6 k Ω	12.5 k Ω	8.0 k Ω
		1.1 V	2.2 V	2.8 V

CN5 Thermistor Characteristics.

Thermistor	Temperature	0 °C	20 °C	30 °C
Thermistor ( Pipe temp. )		176.0 k Ω	62.9 k Ω	39.6 k Ω
		1.1 V	2.2 V	2.8 V

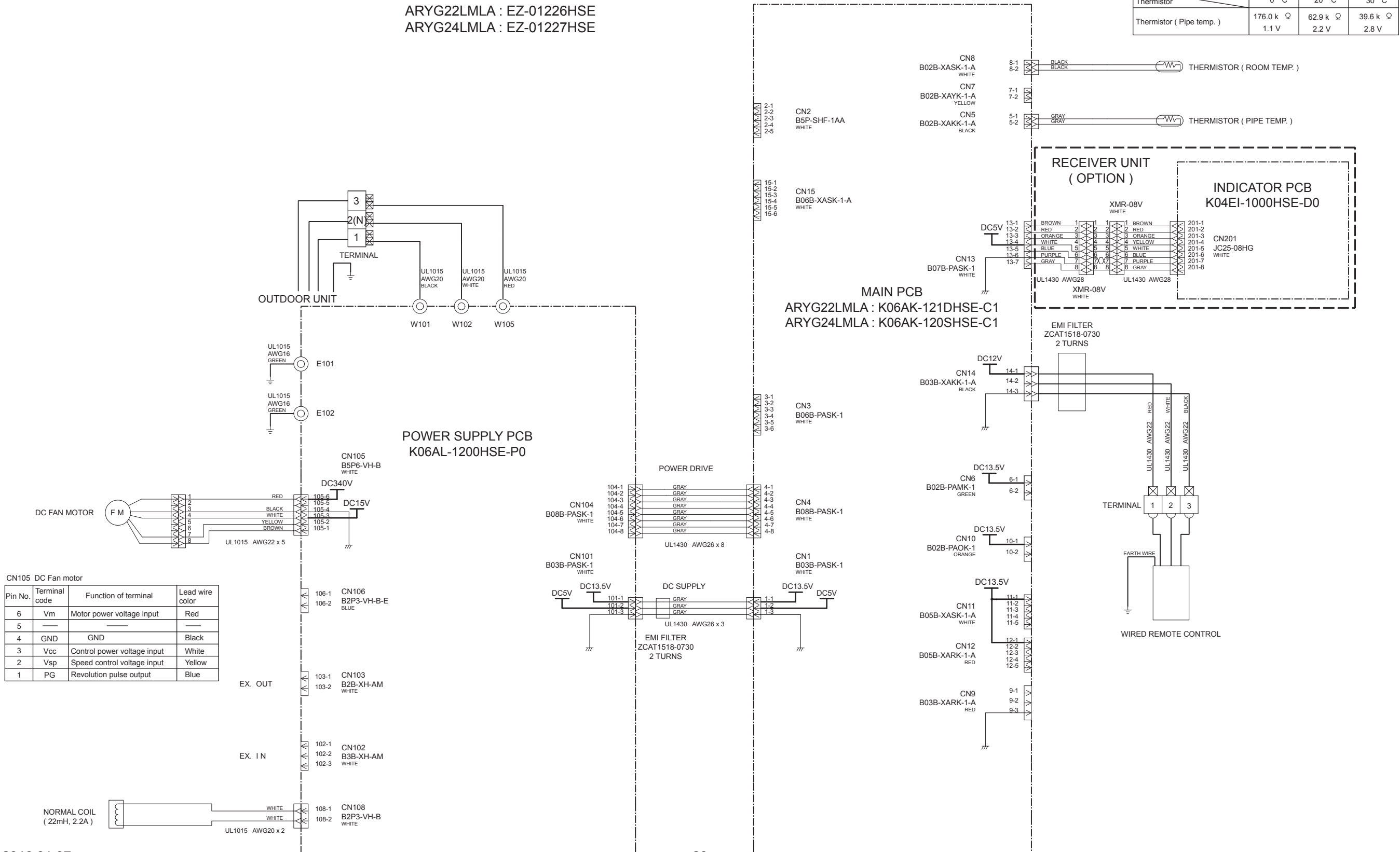

# INDOOR UNIT CASSETTE

**CONTROL UNIT**  
 AUYG18LVLB : EZ-0122LHSE  
 AUYG22LVLA : EZ-01230HSE  
 AUYG24LVLA : EZ-0122MHSE

CN8 Thermistor Characteristics.

Thermistor	Temperature	0 °C	20 °C	30 °C
Thermistor ( room temp. )		33.6 k Ω	12.5 k Ω	8.0 k Ω
		1.1 V	2.2 V	2.8 V

CN5 Thermistor Characteristics.

Thermistor	Temperature	0 °C	20 °C	30 °C
Thermistor ( Pipe temp. )		176.0 k Ω	62.9 k Ω	39.6 k Ω
		1.1 V	2.2 V	2.8 V

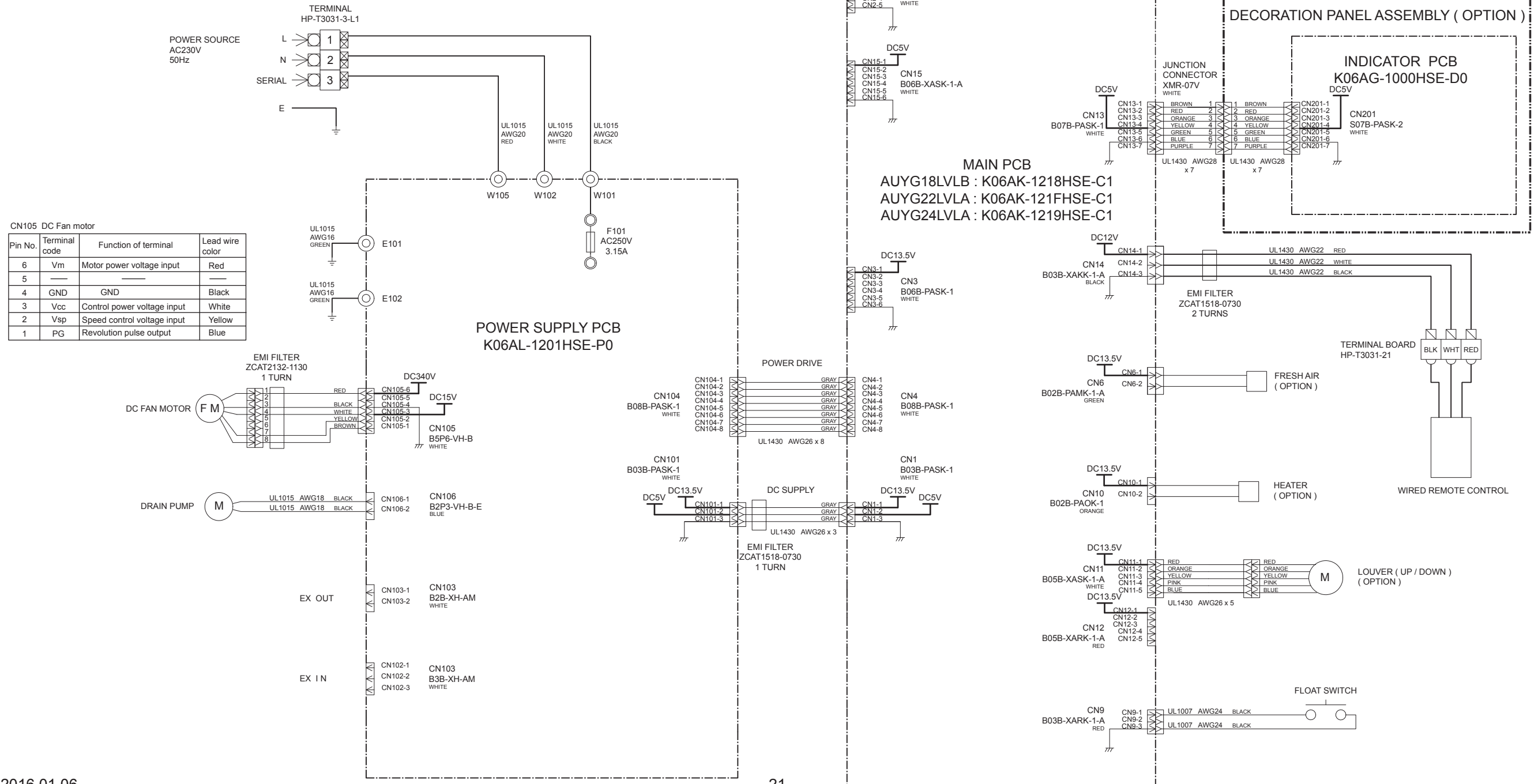

# ERROR DETECTION

## OUTDOOR UNIT ERROR CODE DISPLAY

You can determine the operating status by the lighting up and blinking of the LED lamp.

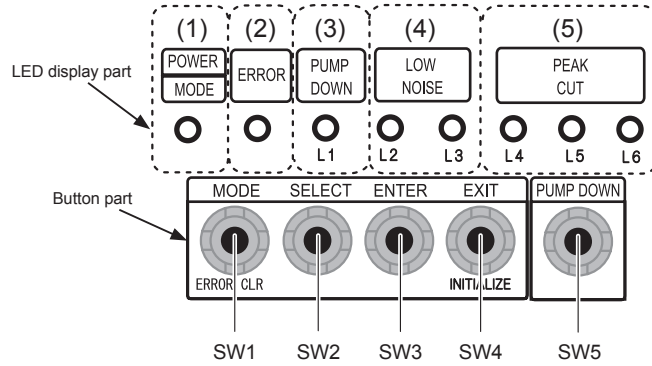

### Display when an error occurs

POWER MODE	ERROR	PUMP DOWN (L1)	LOW NOISE (L2)	(L3)	PEAK CUT (L4)	(L5)	(L6)
●	Blink (Hi speed)	○	○	○	○	○	○

Sign "○": Lights off, "●": Lights on

- Check that the "ERROR" LED blinks, then press the [Enter] button once.
- For details, refer to the following table.

Display mode ● : ON  
○ : OFF  
◆ : Blink (0.5s ON / 0.5s OFF)  
( ) : Number of flashing

## Error code check table

POWER MODE	ERROR	LED display						DESCRIPTION	REMARK
		PUMP DOWN (L1)	LOW NOISE (L2) (L3)			PEAK CUT (L4) (L5) (L6)			
◆(2)	●	◆(1)	◆(1)	○	○	●	●	Serial communication error	Serial forward transmission error immediately after operation
◆(2)	●	◆(1)	◆(1)	○	●	○	○		Serial forward transmission error during operation
◆(2)	●	◆(2)	◆(2)	○	○	○	●	Indoor unit capacity error	Indoor unit capacity error
◆(2)	●	◆(5)	◆(15)	○	○	○	●	Indoor unit error	Indoor unit error
◆(2)	●	◆(6)	◆(2)	○	○	○	●	Outdoor unit main PCB error	Outdoor unit PCB model information error
◆(2)	●	◆(6)	◆(3)	○	○	○	●	Inverter PCB error	Inverter error
◆(2)	●	◆(6)	◆(5)	○	○	●	●	IPM error	Trip terminal L error
◆(2)	●	◆(7)	◆(1)	○	○	○	●	Discharge temp. sensor error	Discharge temp. sensor 1 error
◆(2)	●	◆(7)	◆(2)	○	○	○	●	Compressor temp. sensor error	Compressor temp. sensor 1 error
◆(2)	●	◆(7)	◆(3)	○	○	●	○	Outdoor unit Heat Ex. sensor error	Heat Ex. middle temp. sensor error
◆(2)	●	◆(7)	◆(3)	○	○	●	●		Outdoor unit Heat Ex. liquid temp. sensor error
◆(2)	●	◆(7)	◆(4)	○	○	○	●	Outdoor temp. sensor error	Outdoor temp. sensor error
◆(2)	●	◆(7)	◆(7)	○	○	○	●	Heat sink temp. sensor error	Heat sink temp. sensor error
◆(2)	●	◆(8)	◆(4)	○	○	○	●	Current sensor error	Current sensor 1 error (stoppage permanently)
◆(2)	●	◆(8)	◆(6)	○	●	○	○	Pressure sensor error	High pressure switch 1 error
◆(2)	●	◆(8)	◆(6)	○	●	●	○		Pressure sensor error
◆(2)	●	◆(9)	◆(4)	○	○	○	●	Trip detection	Trip detection
◆(2)	●	◆(9)	◆(5)	○	○	○	●	Compressor motor control error	Rotor position detection error (stoppage permanently)
◆(2)	●	◆(9)	◆(7)	○	○	●	●	Outdoor unit fan motor 1 error	Duty error
◆(2)	●	◆(9)	◆(8)	○	○	●	●	Outdoor unit fan motor 2 error	Duty error
◆(2)	●	◆(9)	◆(9)	○	○	○	●	4-way valve error	4-way valve error
◆(2)	●	◆(10)	◆(1)	○	○	○	●	Discharge temp. 1 error	Discharge temp. 1 error
◆(2)	●	◆(10)	◆(3)	○	○	○	●	Compressor temp. error	Compressor 1 temp. error
◆(2)	●	◆(10)	◆(5)	○	○	○	●	Pressure error 2	Low pressure error

## WIRED REMOTE CONTROL

This is possible only on a wired remote control.

If an error occurs, the following display will be shown.  
 (“Er” will appear in the set room temperature display.)

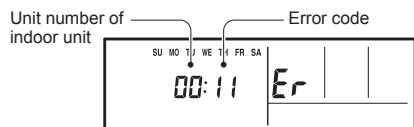

EX. Self-diagnosis

## INDOOR UNIT (CEILING)

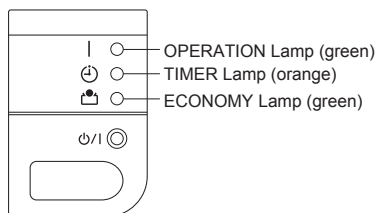

## INDOOR UNIT (CASSETTE)

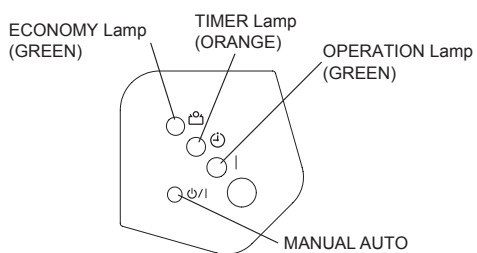

- : 0.5s on / 0.5s off
- ◇ : 0.1s on / 0.1s off
- ( ) : Number of flashing

Indoor unit			Wired remote control	Description
OPERATION lamp (green)	TIMER lamp (orange)	ECONOMY lamp (green)		
● (1)	● (1)	◇	11	Serial communication error
● (1)	● (2)	◇	12	Wired remote control communication error
● (1)	● (5)	◇	15	Check run unfinished
● (2)	● (1)	◇	21	Unit number or Refrigerant circuit address setting error [Simultaneous Multi]
● (2)	● (2)	◇	22	Indoor unit capacity error
● (2)	● (3)	◇	23	Combination error
● (2)	● (4)	◇	24	• Connection unit number error (indoor slave unit) [Simultaneous Multi] • Connection unit number error (indoor unit or branch unit) [Flexible Multi]
● (2)	● (7)	◇	27	Master unit, slave unit set-up error [Simultaneous Multi]
● (3)	● (1)	◇	31	Power supply interruption error
● (3)	● (2)	◇	32	Indoor unit PCB model information error
● (3)	● (5)	◇	35	Manual auto switch error
● (4)	● (1)	◇	41	Inlet air temp. sensor error
● (4)	● (2)	◇	42	Indoor unit Heat Ex. Middle temp. sensor error
● (5)	● (1)	◇	51	Indoor unit fan motor error
● (5)	● (3)	◇	53	Drain pump error
● (5)	● (7)	◇	57	Damper error
● (5)	● (15)	◇	5U	Indoor unit error
● (6)	● (2)	◇	62	Outdoor unit main PCB model information error or communication error
● (6)	● (3)	◇	63	Inverter error
● (6)	● (4)	◇	64	Active filter error, PFC circuit error
● (6)	● (5)	◇	65	Trip terminal L error
● (6)	● (10)	◇	6A	Display PCB microcomputers communication error

Indoor unit			Wired remote control	Description
OPERATION lamp (green)	TIMER lamp (orange)	ECONOMY lamp (green)		
● (7)	● (1)	◇	71	Discharge temp. sensor error
● (7)	● (2)	◇	72	Compressor temp. sensor error
● (7)	● (3)	◇	73	Outdoor unit Heat Ex. liquid temp. sensor error
● (7)	● (4)	◇	74	Outdoor temp. sensor error
● (7)	● (5)	◇	75	Suction Gas temp. sensor error
● (7)	● (6)	◇	76	• 2-way valve temp. sensor error • 3-way valve temp. sensor error
● (7)	● (7)	◇	77	Heat sink temp. sensor error
● (8)	● (2)	◇	82	• Sub-cool Heat Ex. gas inlet temp. sensor error • Sub-cool Heat Ex. gas outlet temp. sensor error
● (8)	● (3)	◇	83	Liquid pipe temp. sensor error
● (8)	● (4)	◇	84	Current sensor error
● (8)	● (6)	◇	86	• Discharge pressure sensor error • Suction pressure sensor error • High pressure switch error
● (9)	● (4)	◇	94	Trip detection
● (9)	● (5)	◇	95	Compressor rotor position detection error (permanent stop)
● (9)	● (7)	◇	97	Outdoor unit fan motor 1 error
● (9)	● (8)	◇	98	Outdoor unit fan motor 2 error
● (9)	● (9)	◇	99	4-way valve error
● (9)	● (10)	◇	9A	Coil (expansion valve) error
● (10)	● (1)	◇	A1	Discharge temp. error
● (10)	● (3)	◇	A3	Compressor temp. error
● (10)	● (4)	◇	A4	High pressure error
● (10)	● (5)	◇	A5	Low pressure error
● (13)	● (2)	◇	J2	Branch boxes error [Flexible Multi]

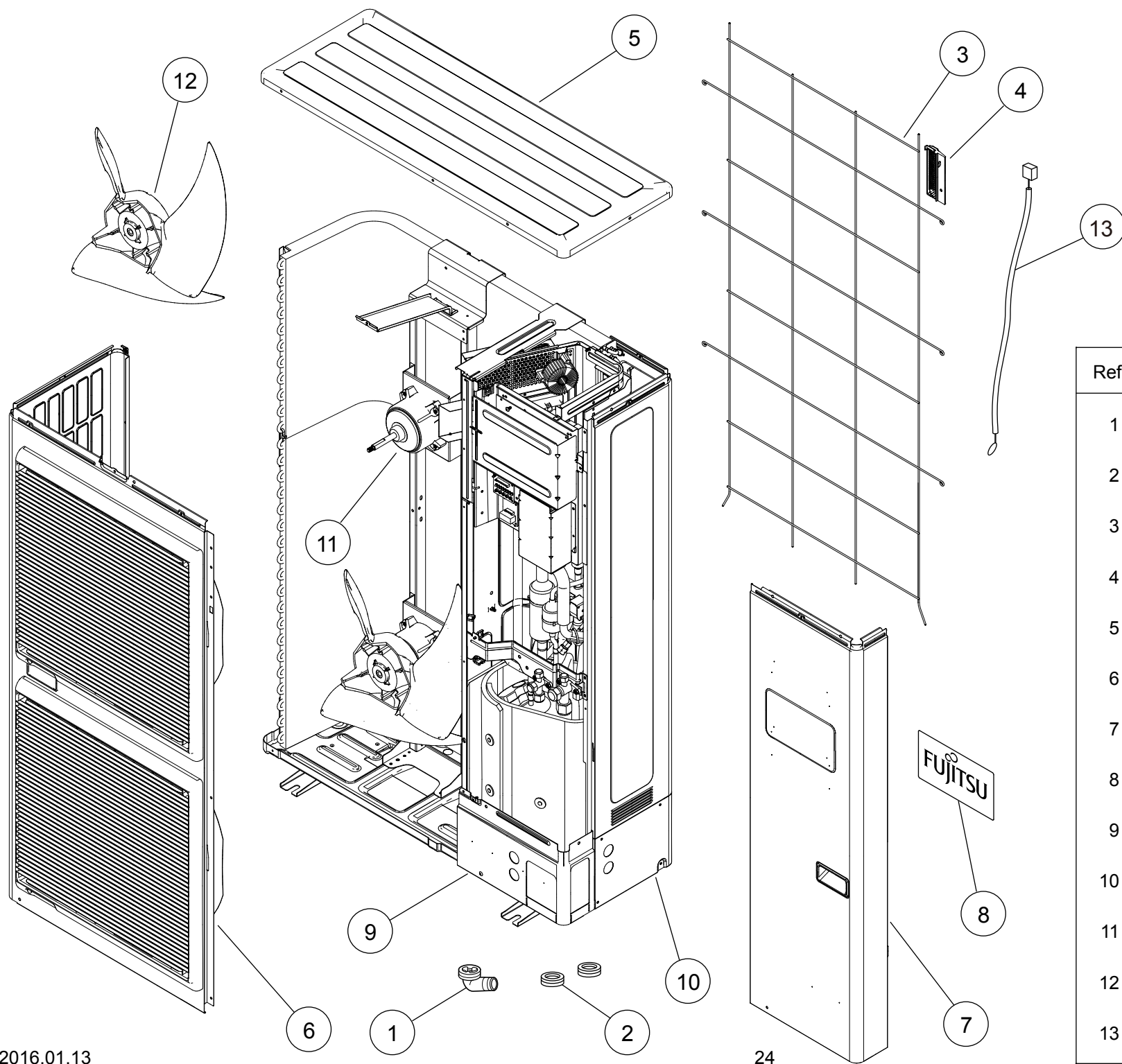

# PARTS

OUTDOOR UNIT  
 AOYG36LBTB  
 AOYG45LBTB  
 AOYG54LBTB

Ref.	Description	Parts number
1	Drain Assy	9303029015
2	Drain Cap	313166024302
3	Protective Net	9375381042
4	Thermo Holder	9375211011
5	Top Panel Sub Assy	9374417056
6	Front Panel Sub Assy	9374414154
7	Sevice Panel Sub Assy	9374415090
8	Emblem Rear	9351355005
9	Pipe Cover Front	9378861015
10	Right Panel Sub Assy	9374416264
11	Motor DC Brushless	9602843039
12	Propeller Fan Assy	9366378020
13	Outdoor Thermistor	9900210069



OUTDOOR UNIT  
 AOYG36LBTB  
 AOYG45LBTB  
 AOYG54LBTB  
 Control box

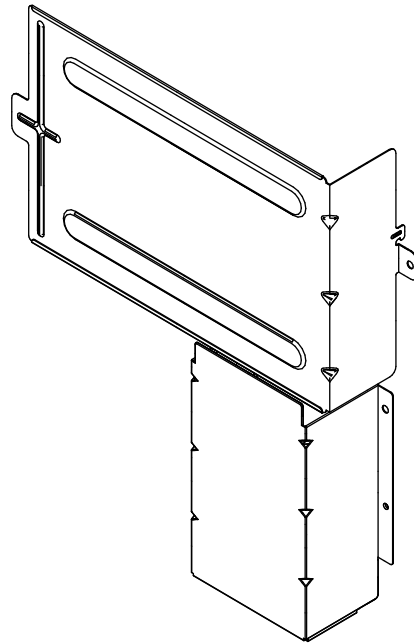
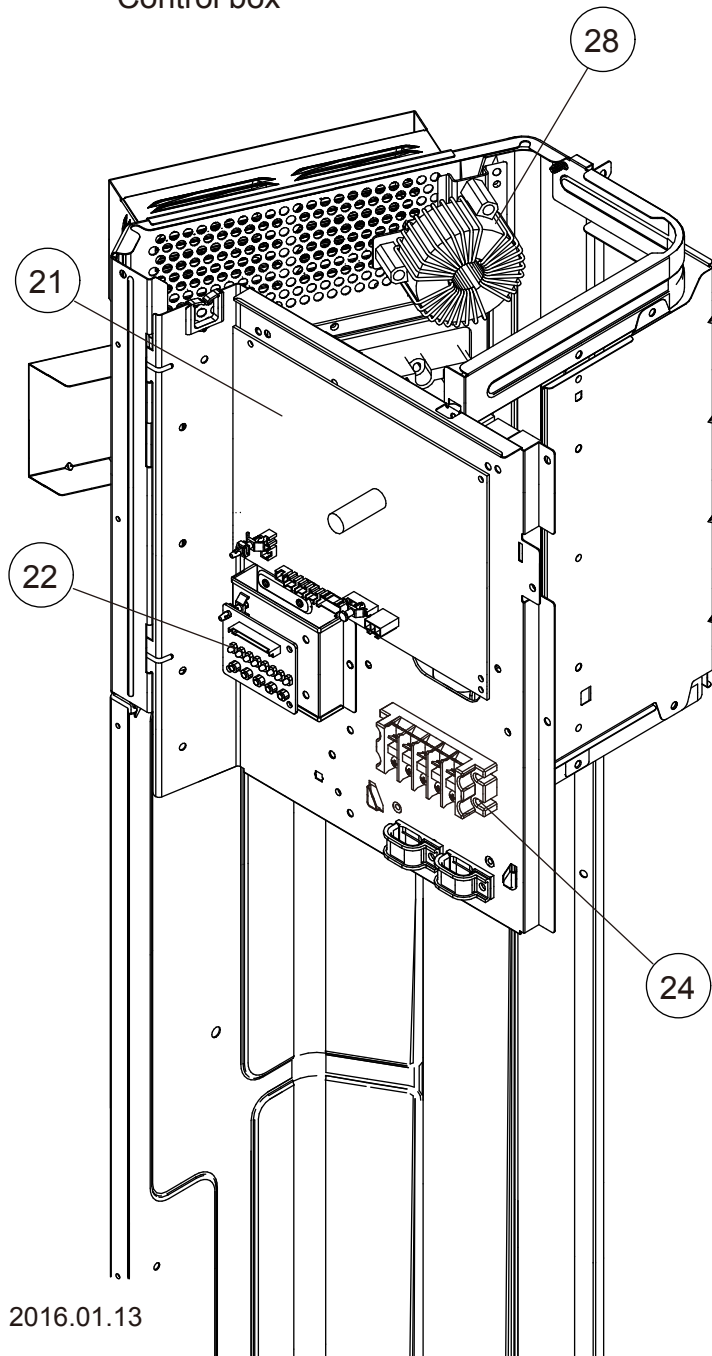

Ref.	Description	Parts number
21	Main PCB (36)	9709904305
21	Main PCB (45)	9709904312
21	Main PCB (54)	9709904329
22	Indicator PCB	9708678016
24	Terminal	9900428020
25	Filter PCB	9709903070
26	Thermistor	9704265012
27	Capacitor PCB	9709894101
28	Choke Coil	9900624019
29	ACTPM	9707592016
30	Transistor PCB	9708646121
31	Heat Sink	9380358008

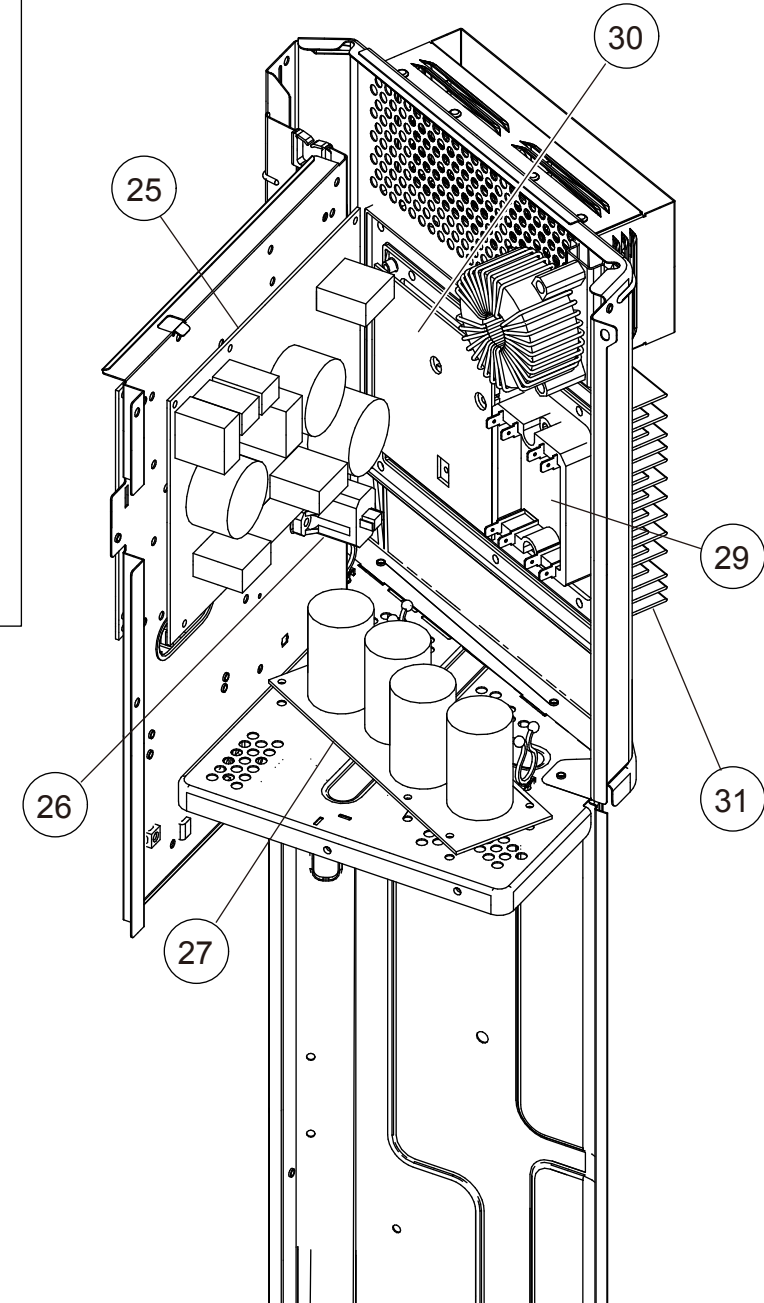

OUTDOOR UNIT  
 AOYG36LBTB  
 AOYG45LBTB  
 AOYG54LBTB

Ref.	Description	Parts number	
61	Thermistor Assy (5 pins)	9900599027	
62	Thermistor Assy (4 pins)	9900598013	
63	Condenser A Sub Assy	9374420261	
64	Condenser B Sub Assy	9374422081	
65	Bypass Pipe A	9371324043	
66	Expansion Valve Coil	9970098062	
67	Expansion Valve Assy	9370947182	
68	3-way Valve Assy	9379077002	
69	3-way Valve Assy	9379079006	
70	Solenoid	9970113055	
71	4-way Valve Assy	9374425273	
72	Sensor	9900505080	
73	Accumulator Assy	9375250096	
74*	Compressor Sub Assy	9374423262	A
74*	Compressor Sub Assy	9374423460	B

Ref.74 : B is interchangeable with A, When there is no stock  
 A, B is shipped automatically.

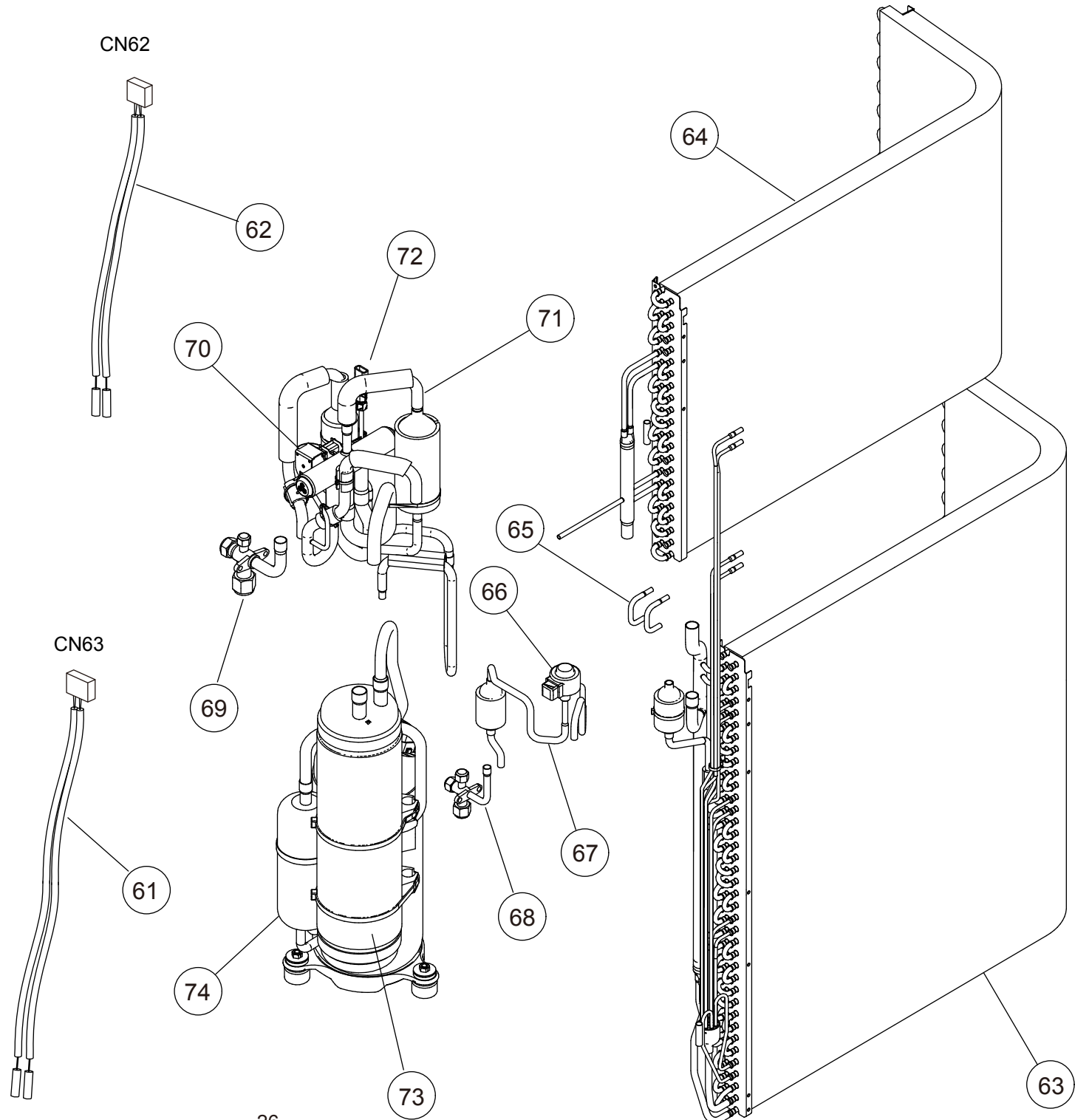

# PARTS

BRANCH PIPE  
UTP-SX236A

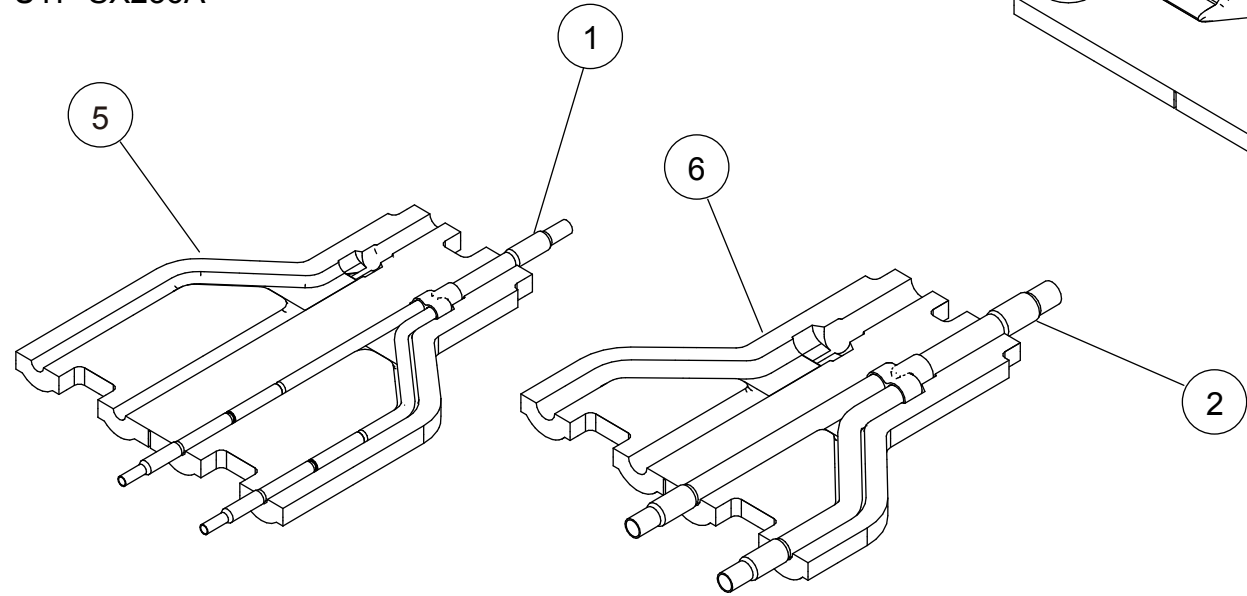

UTP-SX254A

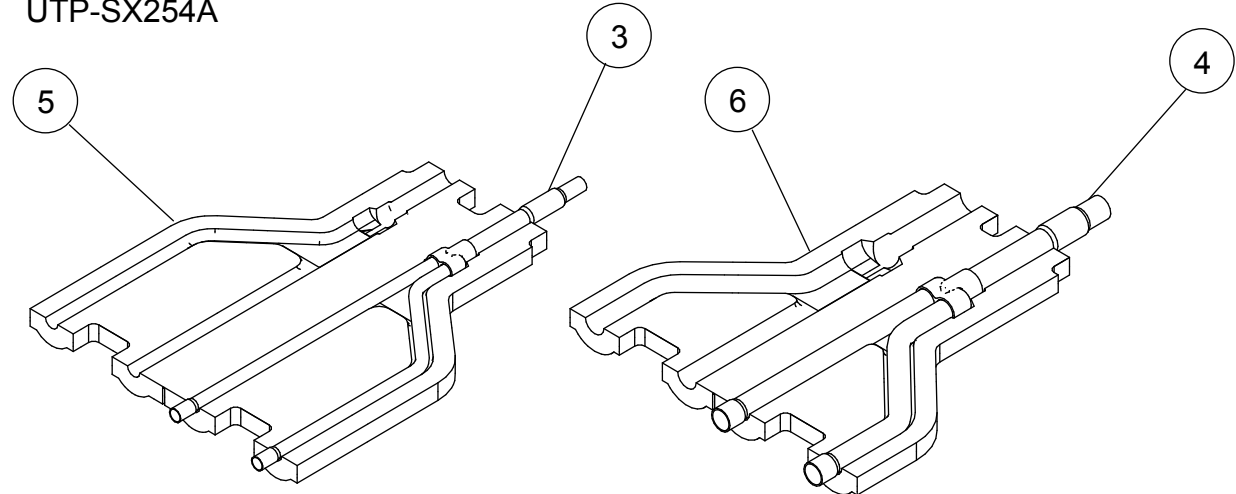

UTP-SX354A

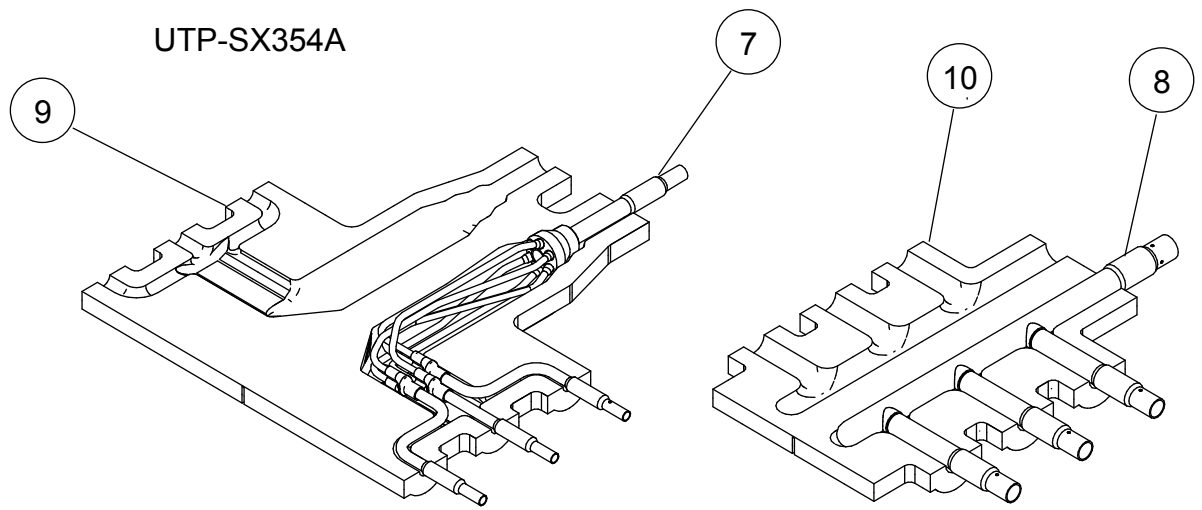

Ref.	Description	Parts number
1	Branch Pipe A Assy	9379090018
2	Branch Pipe B Assy	9379096010
3	Branch Pipe A Assy	9379102018
4	Branch Pipe B Assy	9379105019
5	Insulation A	9379100014
6	Insulation B	9379101011
7	Branch Pipe A Assy	9379116015
8	Branch Header B Assy	9379108010
9	Insulation A	9379111010
10	Insulation B	9379112017



# PARTS

INDOOR UNIT  
 CEILING  
 ABYG18LVTB  
 ABYG22LVTA  
 ABYG24LVTA

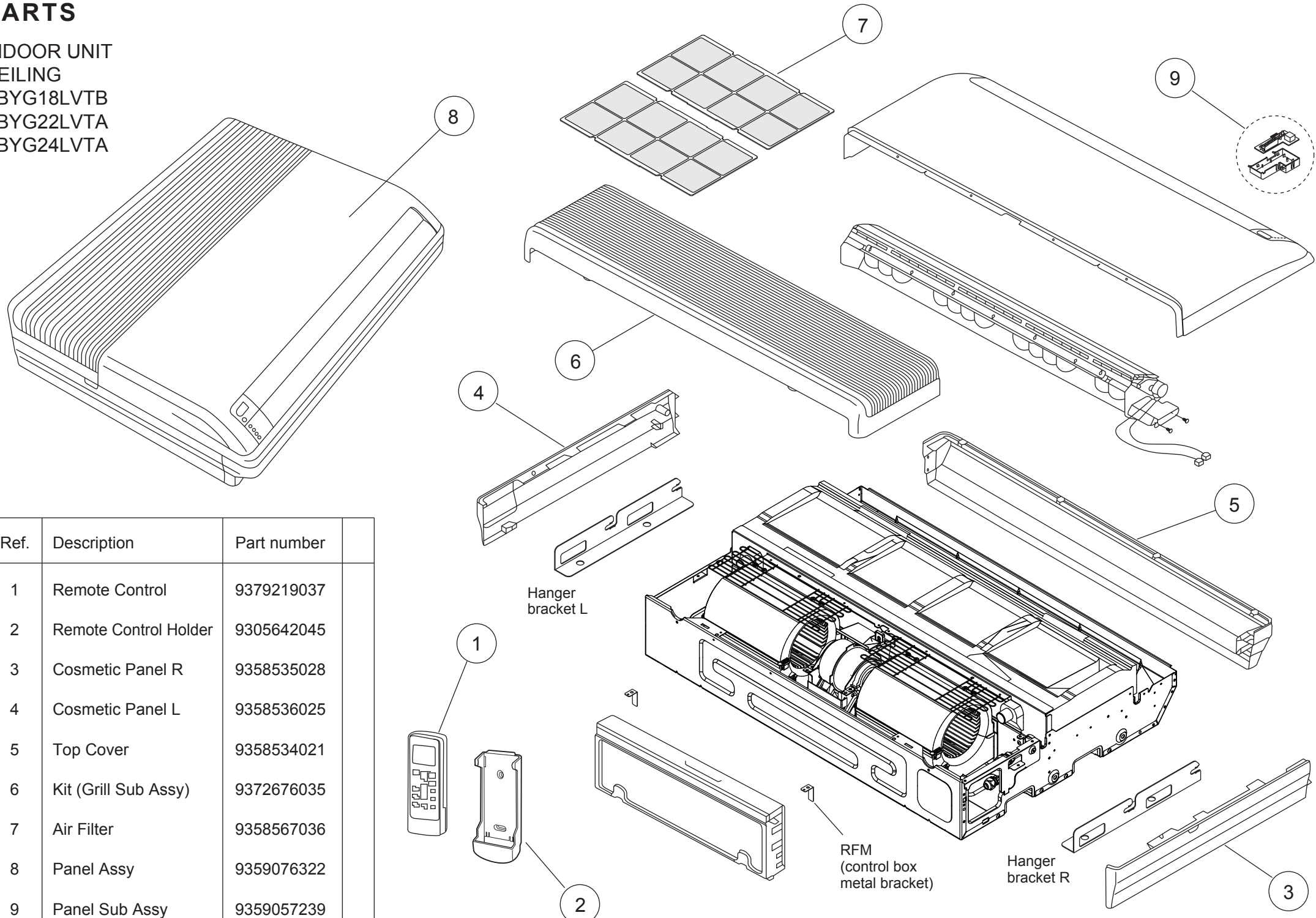

Ref.	Description	Part number
1	Remote Control	9379219037
2	Remote Control Holder	9305642045
3	Cosmetic Panel R	9358535028
4	Cosmetic Panel L	9358536025
5	Top Cover	9358534021
6	Kit (Grill Sub Assy)	9372676035
7	Air Filter	9358567036
8	Panel Assy	9359076322
9	Panel Sub Assy	9359057239

INDOOR UNIT  
 CEILING  
 ABYG18LVTB  
 ABYG22LVTA  
 ABYG24LVTA  
 Flap base assy

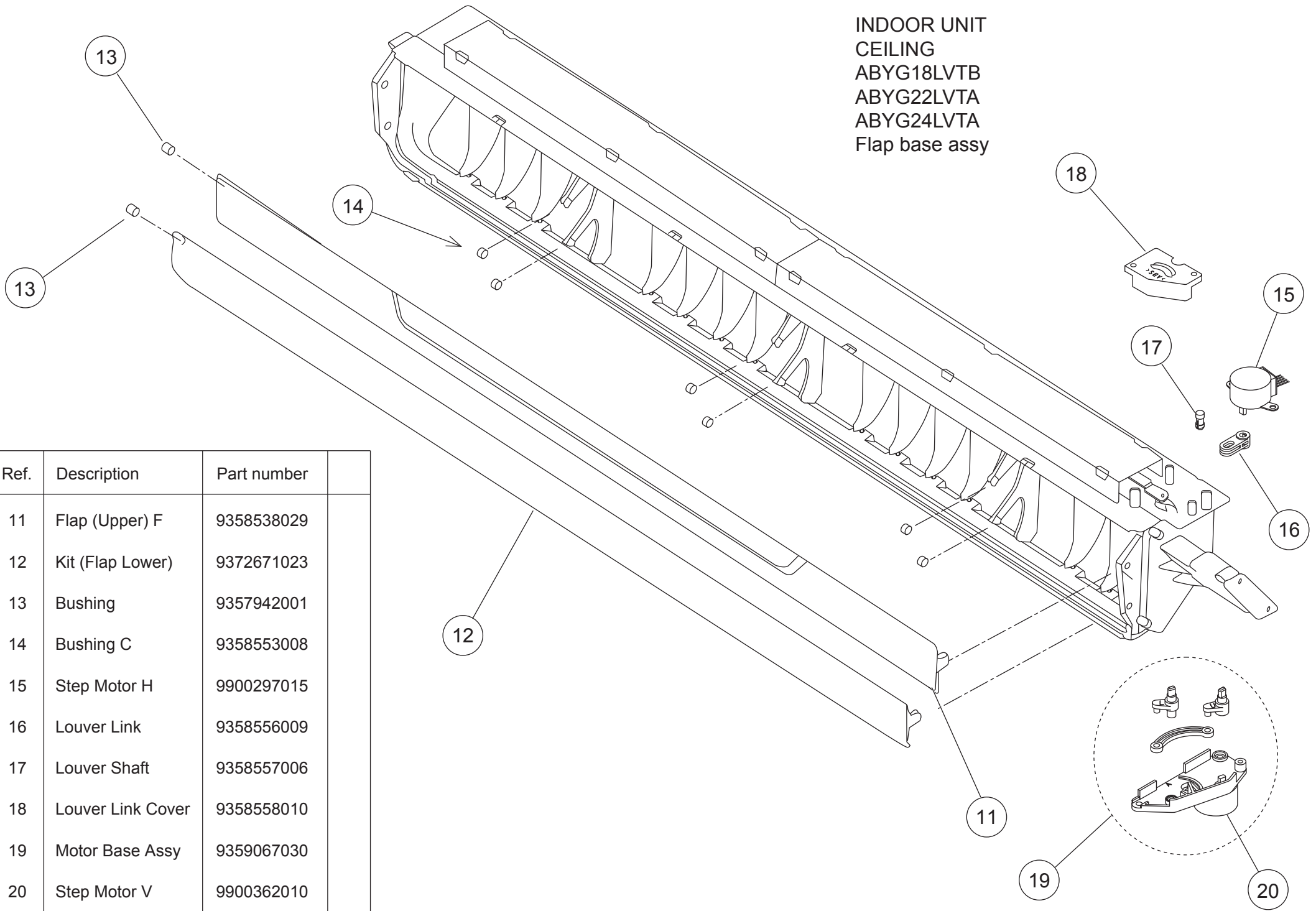

Ref.	Description	Part number
11	Flap (Upper) F	9358538029
12	Kit (Flap Lower)	9372671023
13	Bushing	9357942001
14	Bushing C	9358553008
15	Step Motor H	9900297015
16	Louver Link	9358556009
17	Louver Shaft	9358557006
18	Louver Link Cover	9358558010
19	Motor Base Assy	9359067030
20	Step Motor V	9900362010

INDOOR UNIT  
 CEILING  
 ABYG18LVTB  
 ABYG22LVTA  
 ABYG24LVTA  
 Kit (flap base sub assy)

Ref.	Description	Part number
21	Kit (Flap Base Sub Assy)	9372670040
22	Flap Base	9358537022
23	Protect Cover	9358564011
24	Louver	9358561027
25	Bushing B	9358554005
26	Louver Stopper	9358555002
27	Louver Rod	9358559017
28	Motor Rod	9358560013

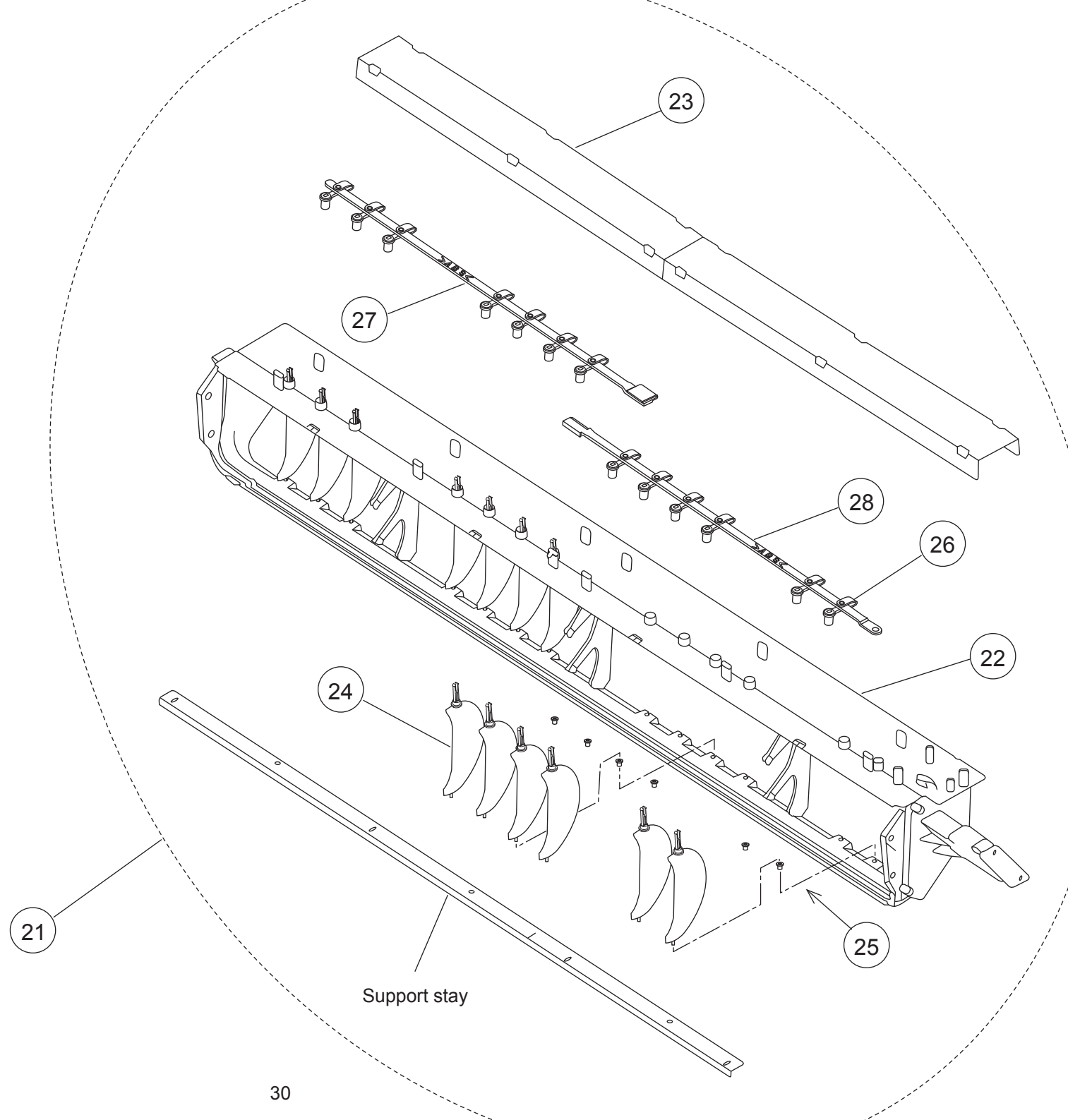

INDOOR UNIT  
 CEILING  
 ABYG18LVTB  
 ABYG22LVTA  
 ABYG24LVTA  
 Fan motor

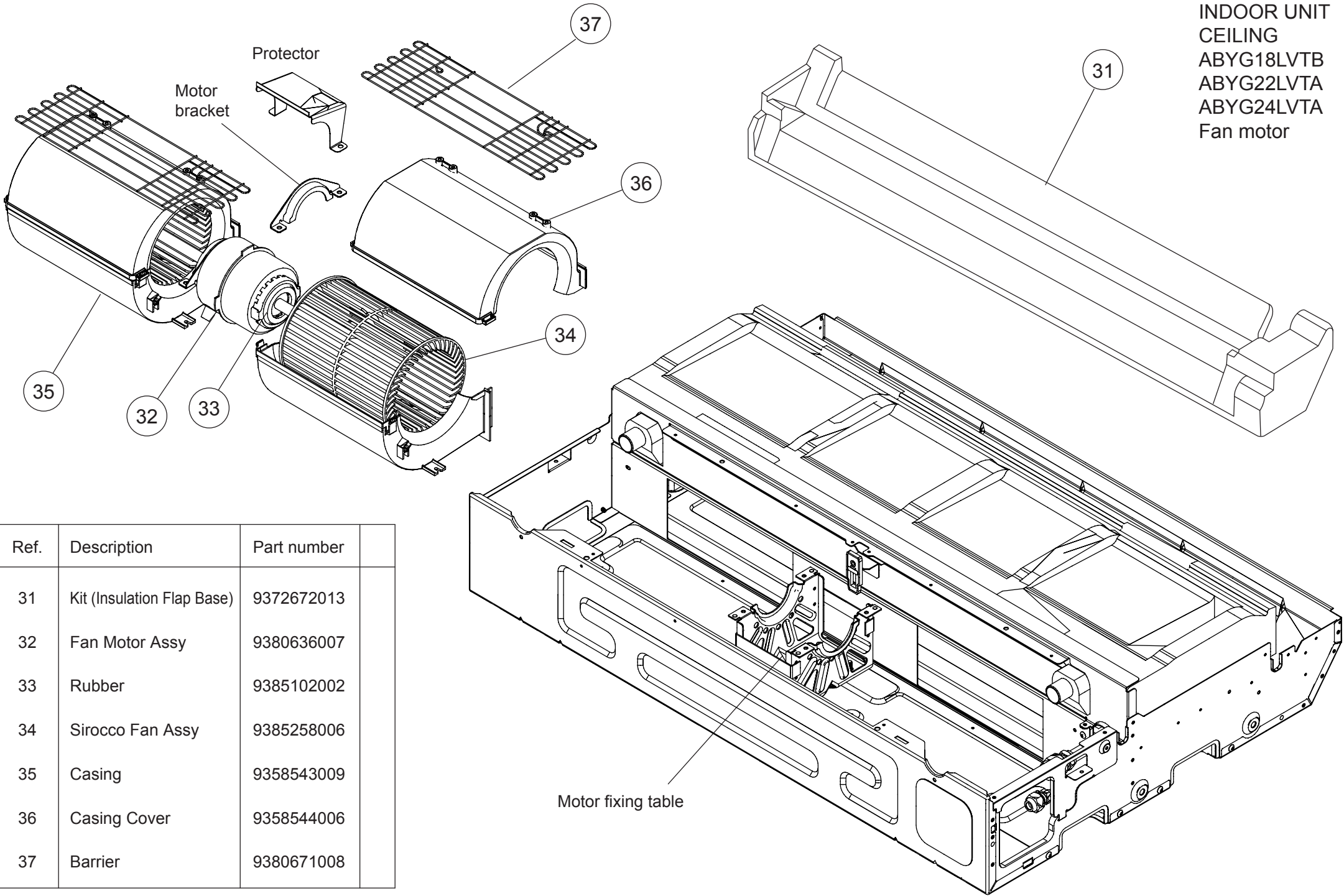

Ref.	Description	Part number
31	Kit (Insulation Flap Base)	9372672013
32	Fan Motor Assy	9380636007
33	Rubber	9385102002
34	Sirocco Fan Assy	9385258006
35	Casing	9358543009
36	Casing Cover	9358544006
37	Barrier	9380671008

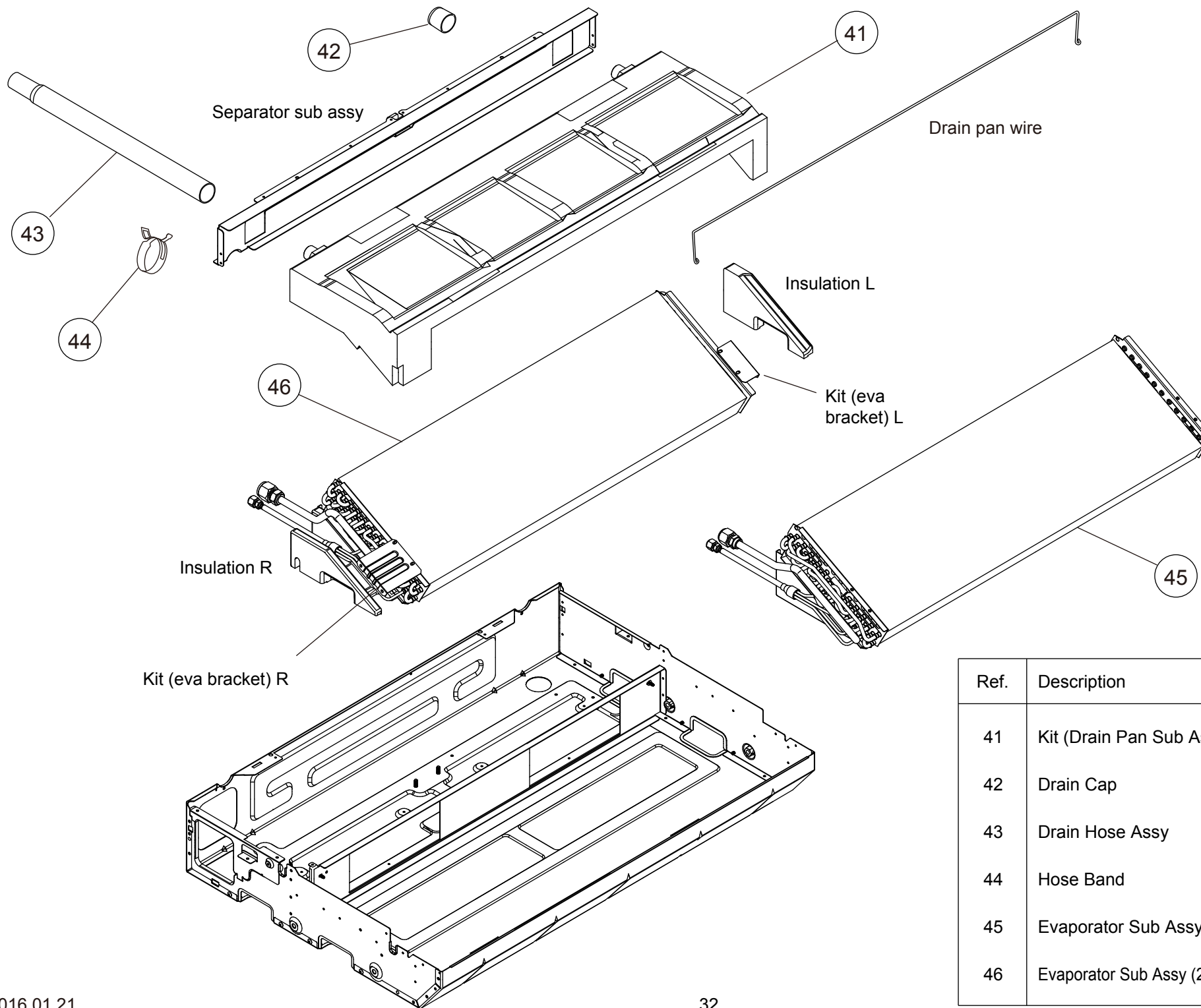

INDOOR UNIT  
 CEILING  
 ABYG18LVTB  
 ABYG22LVTA  
 ABYG24LVTA  
 Evaporator  
 Drain pan

Ref.	Description	Part number
41	Kit (Drain Pan Sub Assy)	9372669013
42	Drain Cap	9358746004
43	Drain Hose Assy	9377785060
44	Hose Band	9379757003
45	Evaporator Sub Assy (18)	9359051275
46	Evaporator Sub Assy (22 24)	9359051268



INDOOR UNIT  
 CEILING  
 ABYG18LVTB  
 ABYG22LVTA  
 ABYG24LVTA  
 Base sub assy  
 Control box

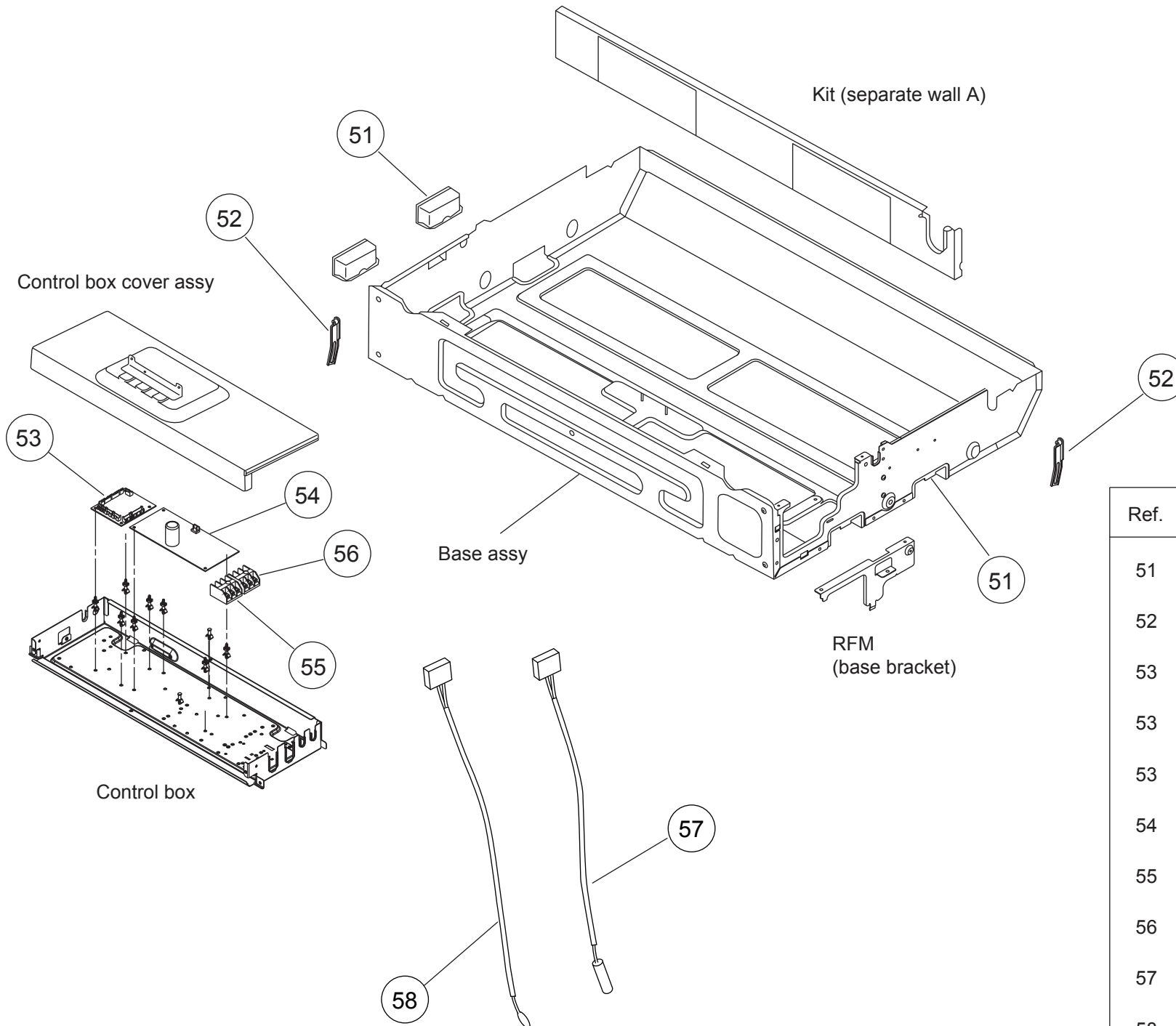

Ref.	Description	Part number
51	Cap	9358563007
52	Arm	9358565001
53	Main PCB (ABYG18)	9709245361
53	Main PCB (ABYG22)	9709245507
53	Main PCB (ABYG24)	9709245378
54	Power Supply PCB	9707398274
55	Terminal 3P	9306489045
56	Terminal 3P	9703345012
57	Pipe Thermistor	9900022020
58	Room Thermistor	9703299087

INDOOR UNIT  
SLIM DUCT  
ARYG18LLTB

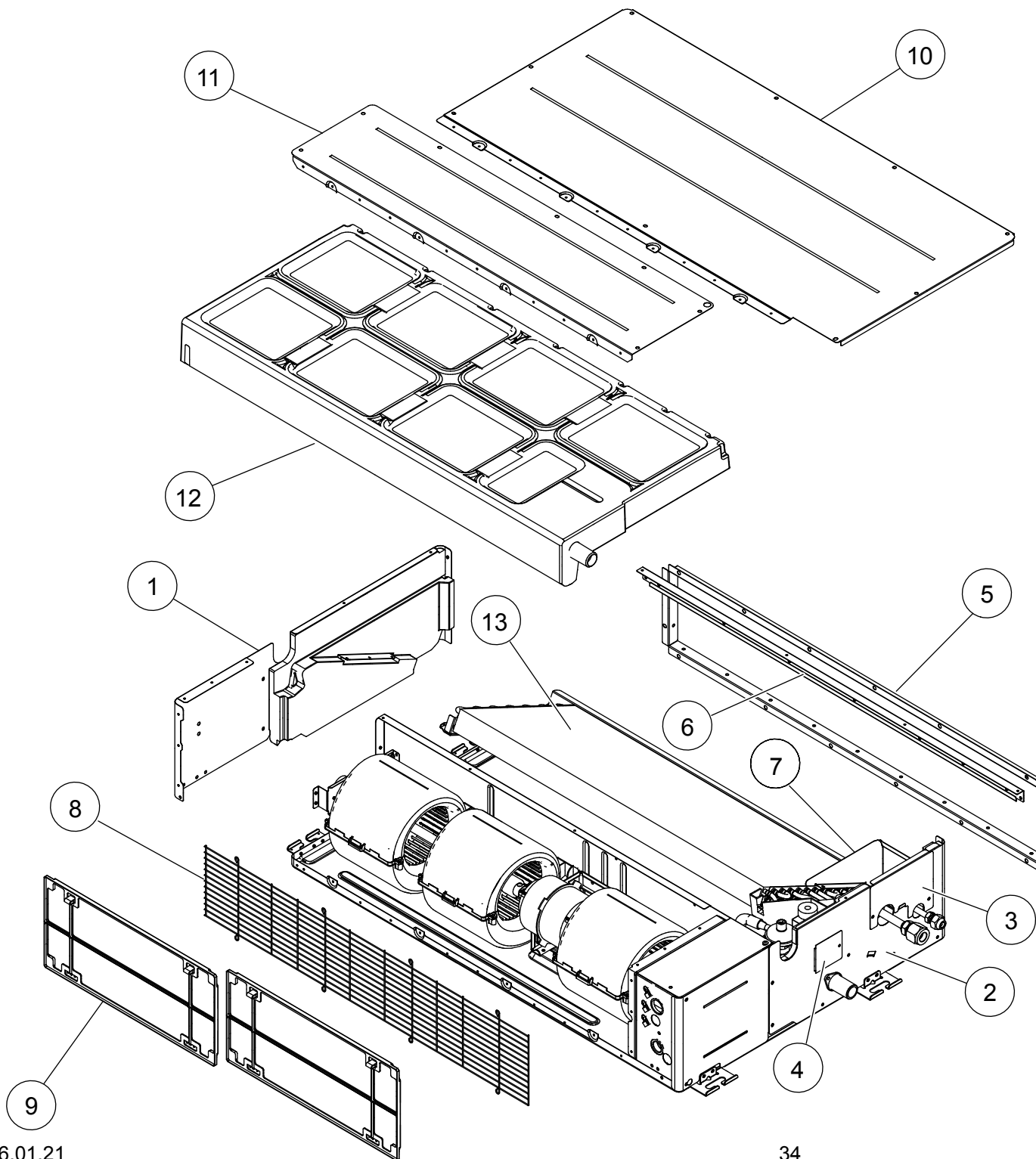

Ref	Description	Parts number
1	Side Panel R Sub Assy	9379906012
2	Side Panel L Sub Assy	9379907019
3	Pipe Panel Sub Assy	9379900003
4	Panel (Window) Sub Assy	9379915007
5	Outlet Frame Assy	9380042013
6	Front Panel (3 Fan)	9380595007
7	Valve Cover Sub Assy	9379576017
8	Fan Guard (3 Fan)	9380590002
9	Air Filter	9379575003
10	Main Panel (3 Fan)	9380603016
11	Cabinet Panel (3 Fan)	9380598008
12	Drain Pan Sub Assy	9379901178
13	Evaporator Total Assy	9380682066

INDOOR UNIT  
SLIM DUCT  
ARYG18LLTB

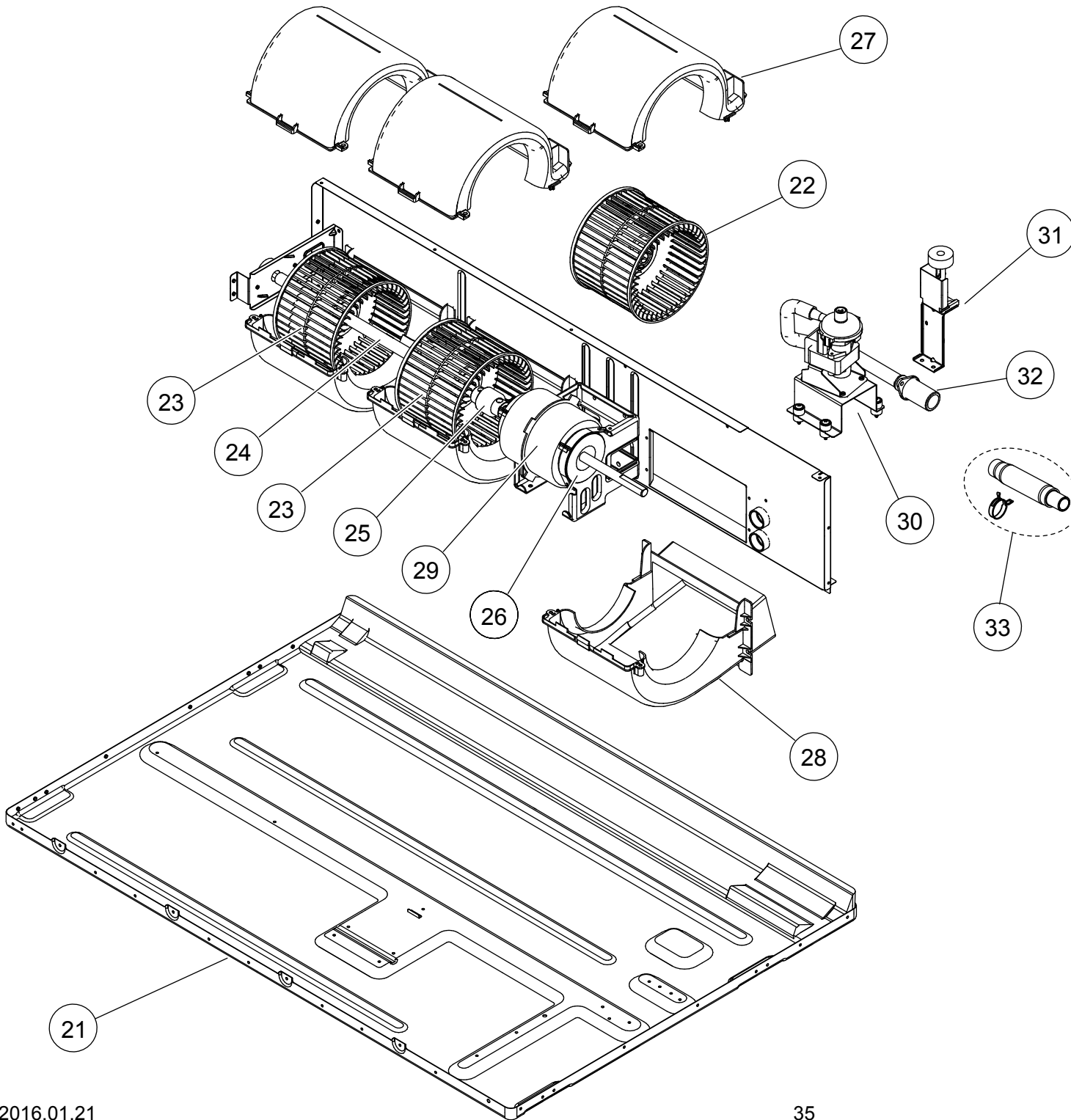

Ref	Description	Parts number
21	Top Panel Sub Assy	9379908047
22	Sirroco Fan Assy	9379570022
23	Sirroco Fan Assy	9379570039
24	Shaft Assy	9381052004
25	Joint Assy	9378038011
26	Rubber (Vibration Proof)	9379644006
27	Casing B	9379572019
28	Casing U	9379571012
29	Fan Motor Assy	9602968022
30	Drain Pump Sub Assy	9379914055
31	Float Switch Sub Assy	9378593022
32	Drain Hose Assy	9379913003
33	Hose Sub Assy	9378450097



INDOOR UNIT  
SLIM DUCT  
ARYG18LLTB

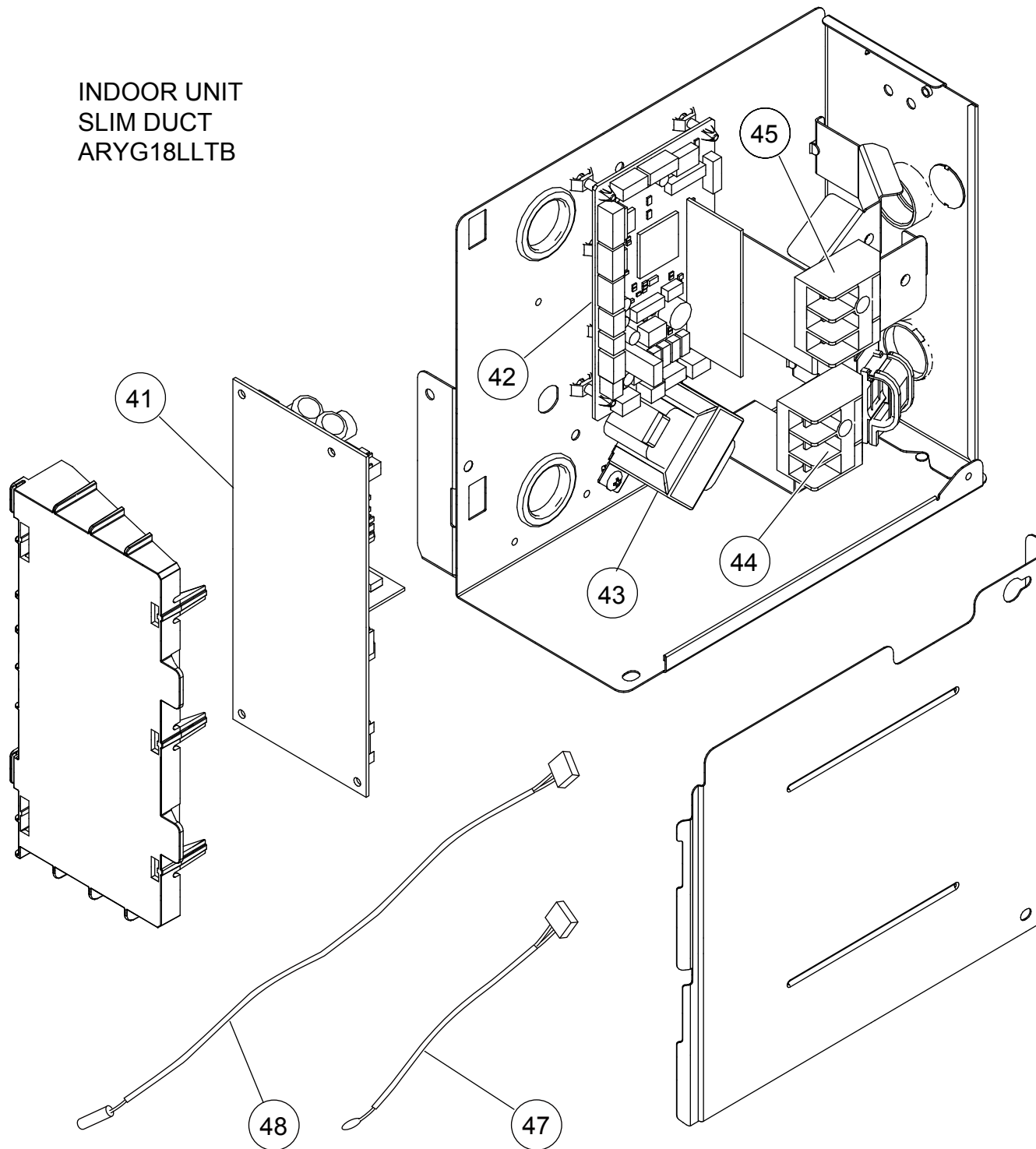

Ref	Description	Parts number
41	Power Supply PCB	9707398267
42	Main PCB	9709245316
43	Reactor Assy	9707457018
44	Terminal 3P	9306489045
45	Terminal 3P (Wired Remote)	9703345012
46	Wired Remote Control	9318593013
47	Room Thermistor	9900653019
48	Pipe Thermistor	9900881016

INDOOR UNIT  
DUCT  
ARYG22LMLA  
ARYG24LMLA

Hook metal

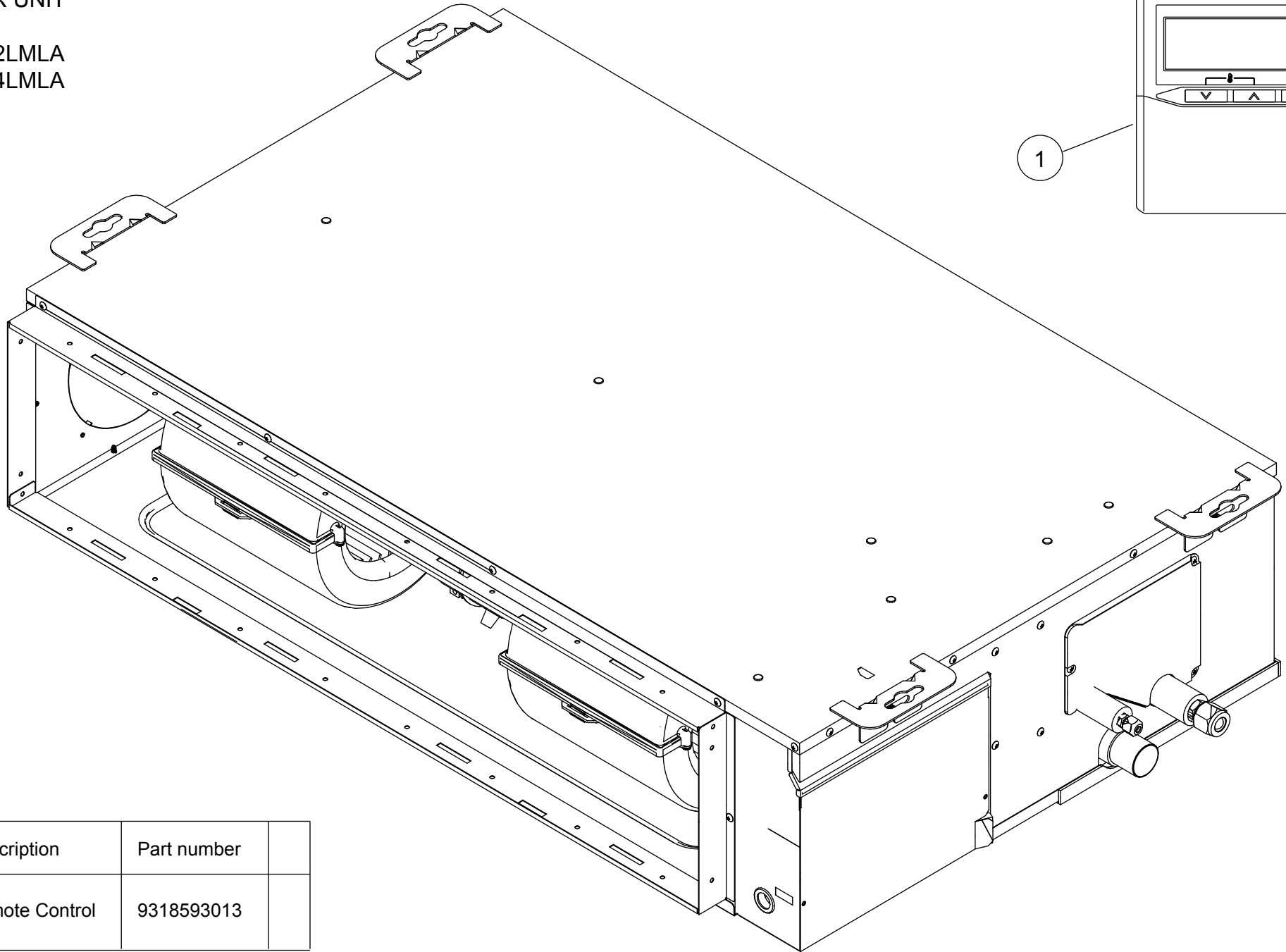

1

Ref.	Description	Part number	
1	Remote Control	9318593013	

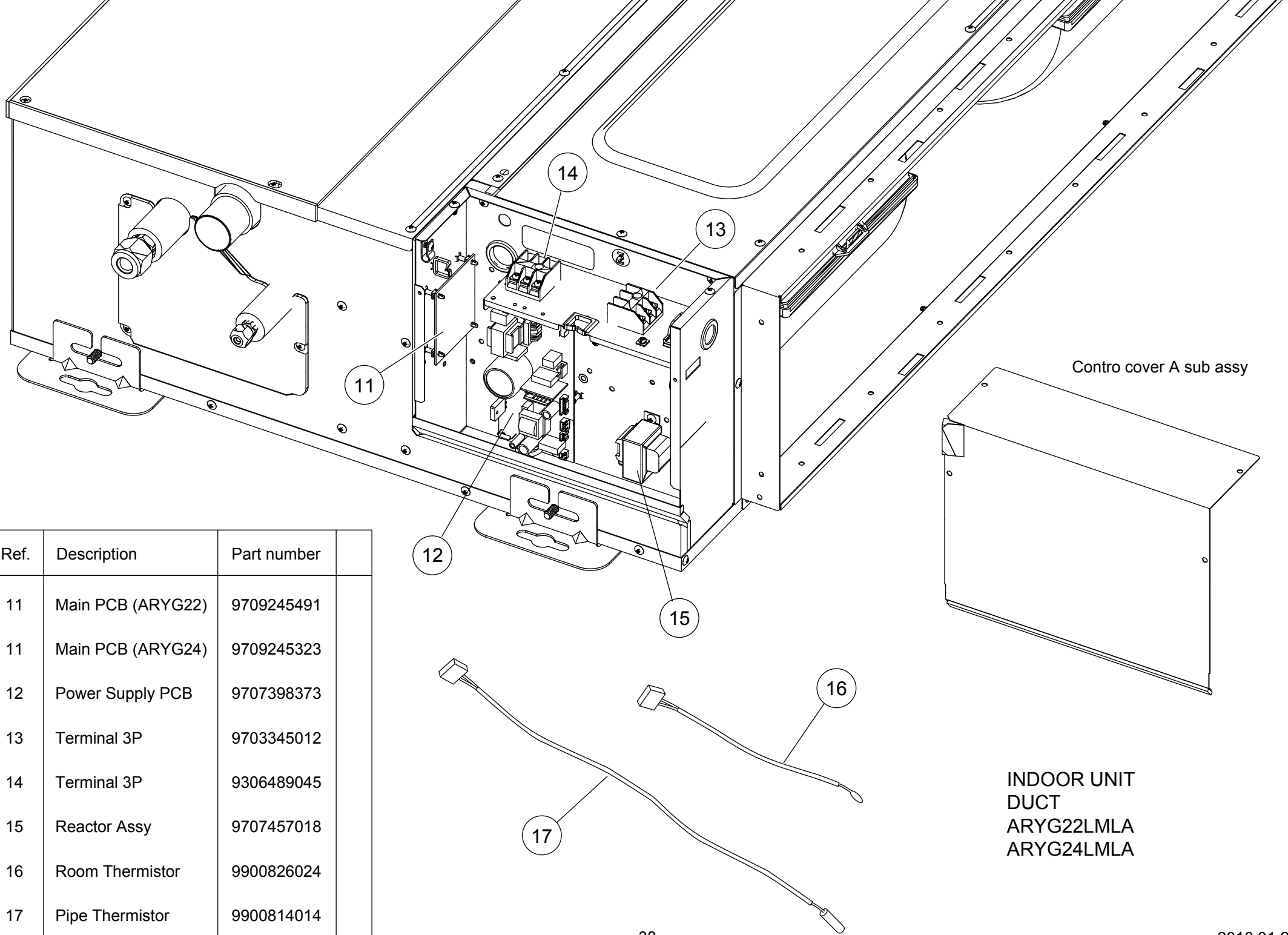

Ref.	Description	Part number
11	Main PCB (ARYG22)	9709245491
11	Main PCB (ARYG24)	9709245323
12	Power Supply PCB	9707398373
13	Terminal 3P	9703345012
14	Terminal 3P	9306489045
15	Reactor Assy	9707457018
16	Room Thermistor	9900826024
17	Pipe Thermistor	9900814014

Contro cover A sub assy

INDOOR UNIT  
DUCT  
ARYG22LMLA  
ARYG24LMLA

Bracket pipe sub assy

Main panel sub assy

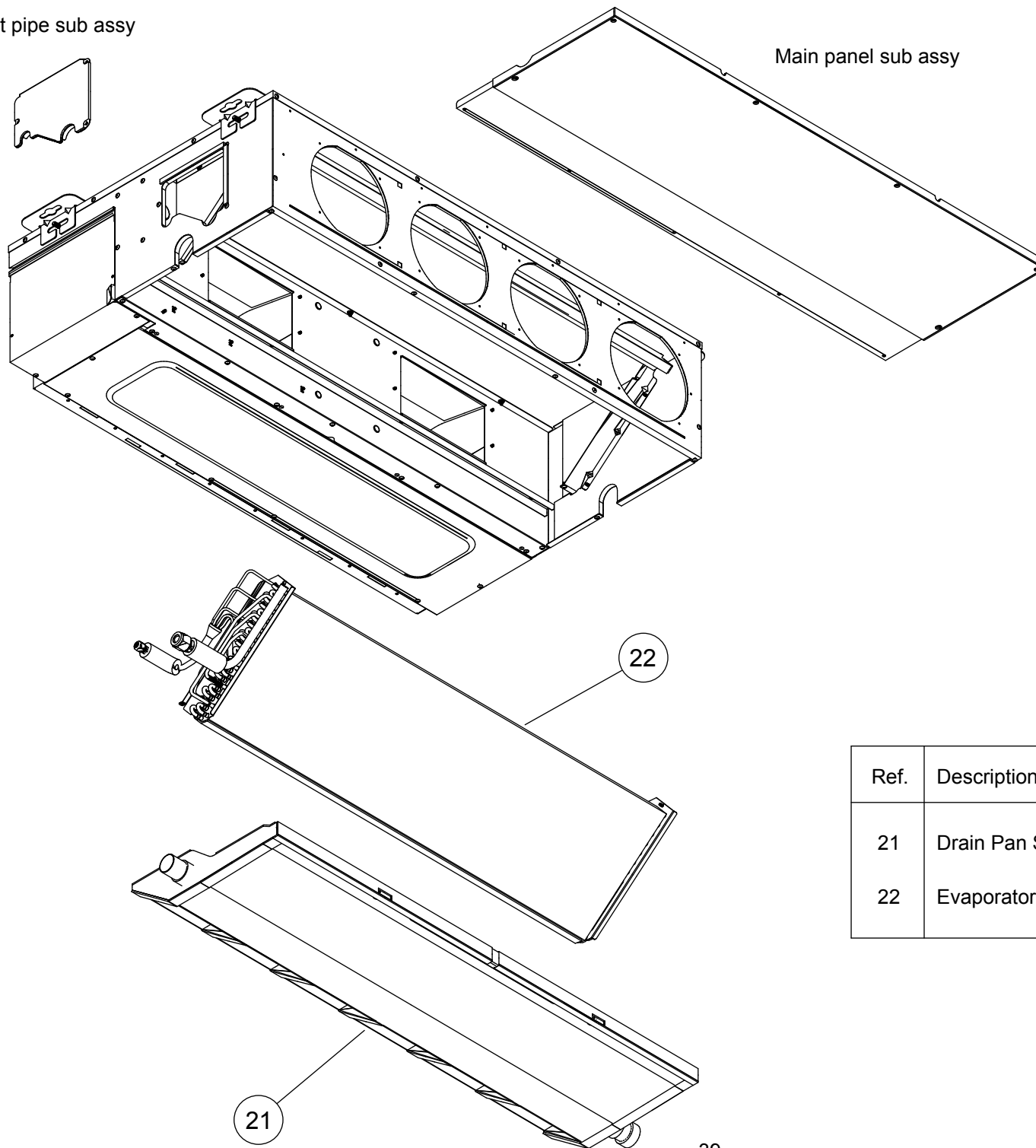

INDOOR UNIT  
DUCT  
ARYG22LMLA  
ARYG24LMLA

Ref.	Description	Part number	
21	Drain Pan Sub Assy	9374513017	
22	Evaporator Total Assy	9374517268	

INDOOR UNIT  
 DUCT  
 ARYG22LMLA  
 ARYG24LMLA

Intake cover sub assy

Intake frame assy

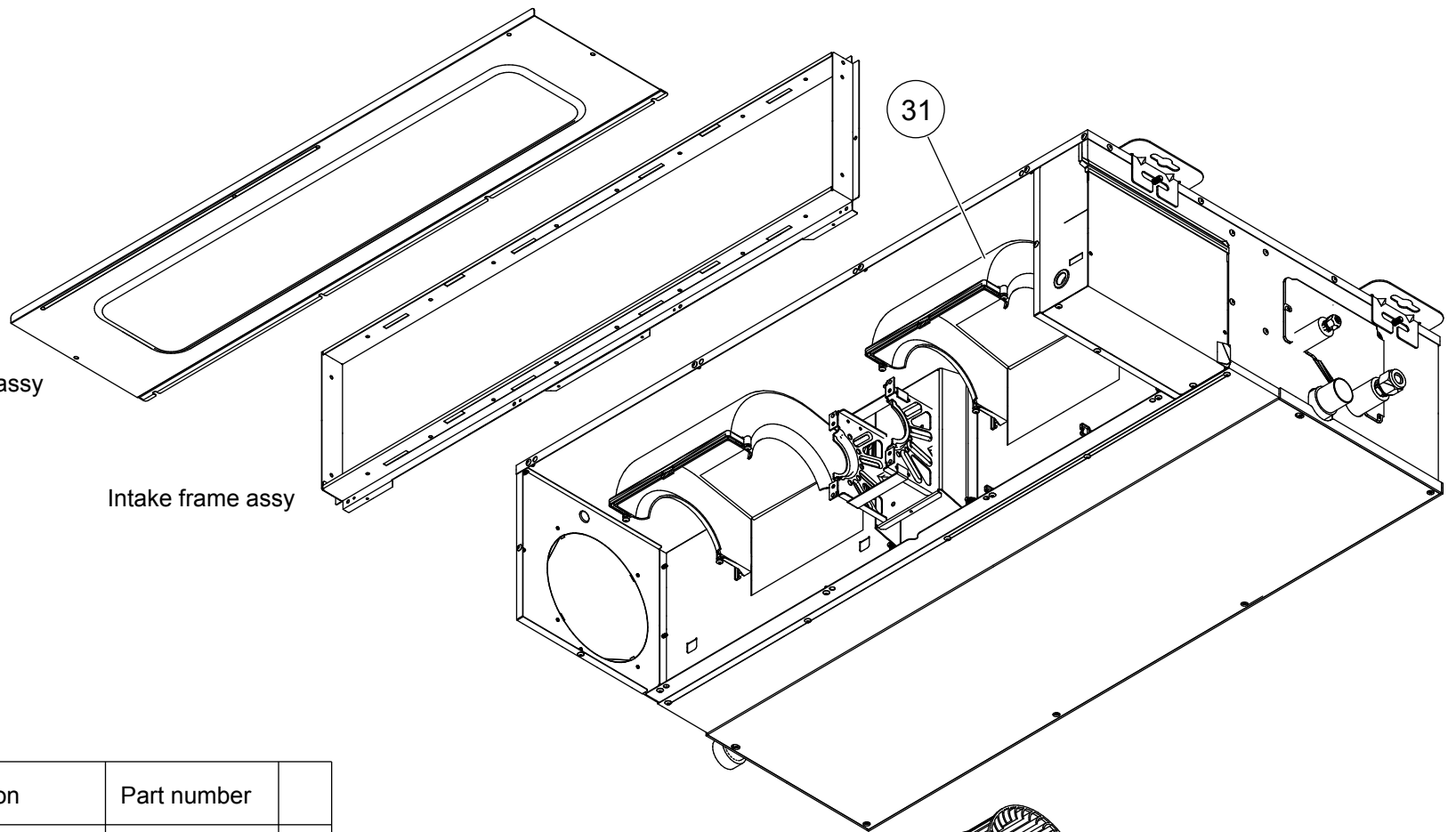

Ref.	Description	Part number
31	Casing A	9374233021
32	Casing B	9374234028
33	Sirocco Fan Assy	9356531060
34	Fan Motor Assy	9380718031
35	Rubber	9385102002

Motor bracket

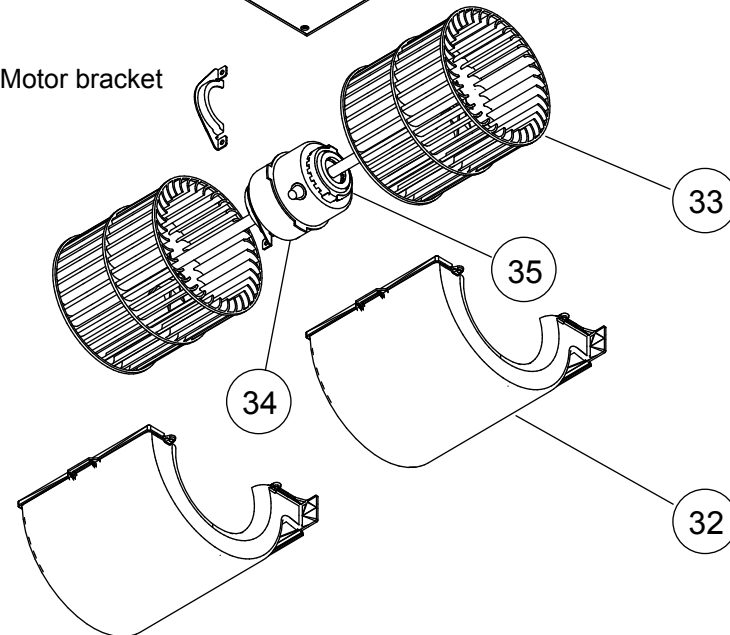

DECORATION PANEL  
UTG-UFYD-W

INDOOR UNIT  
AUYG18LVLB  
AUYG22LVLA  
AUYG24LVLA

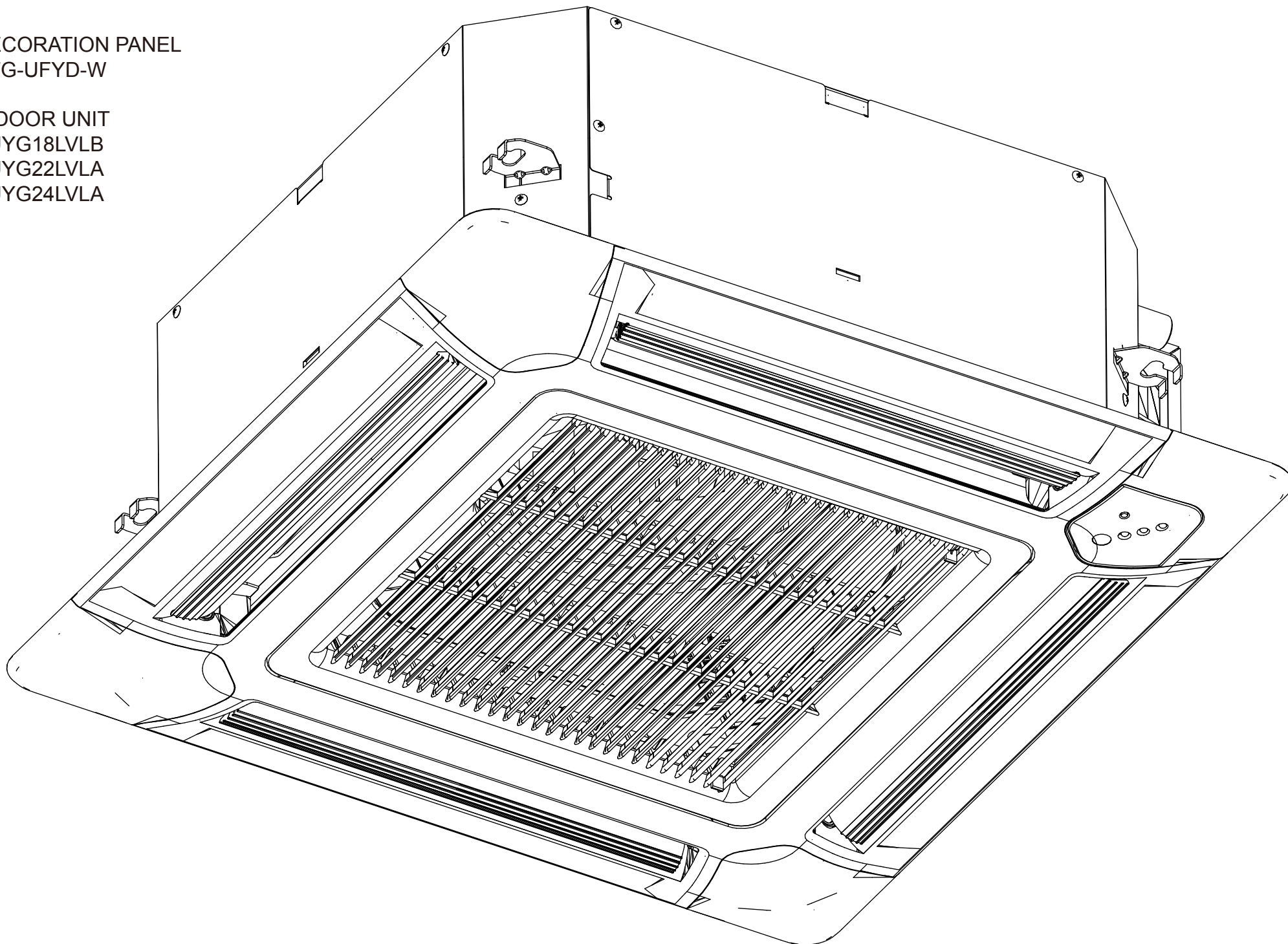

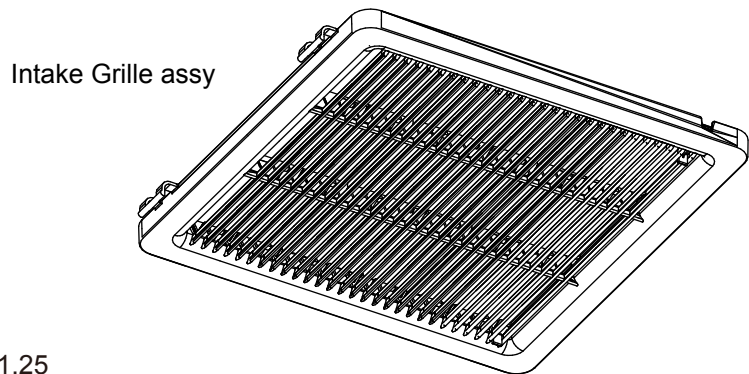
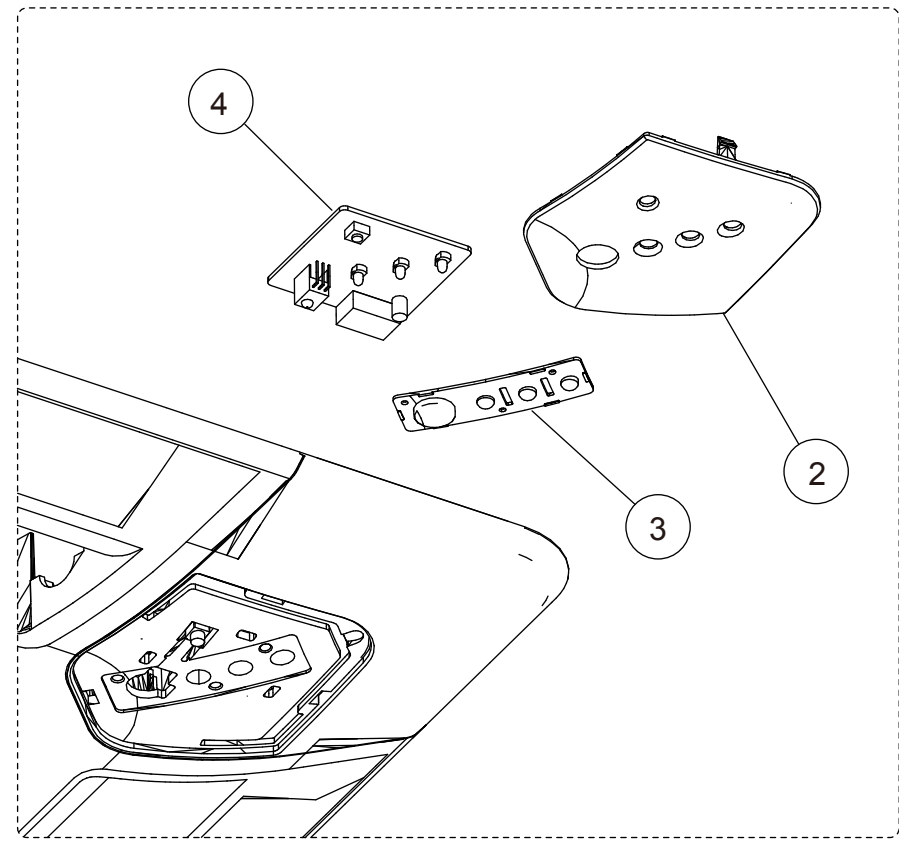
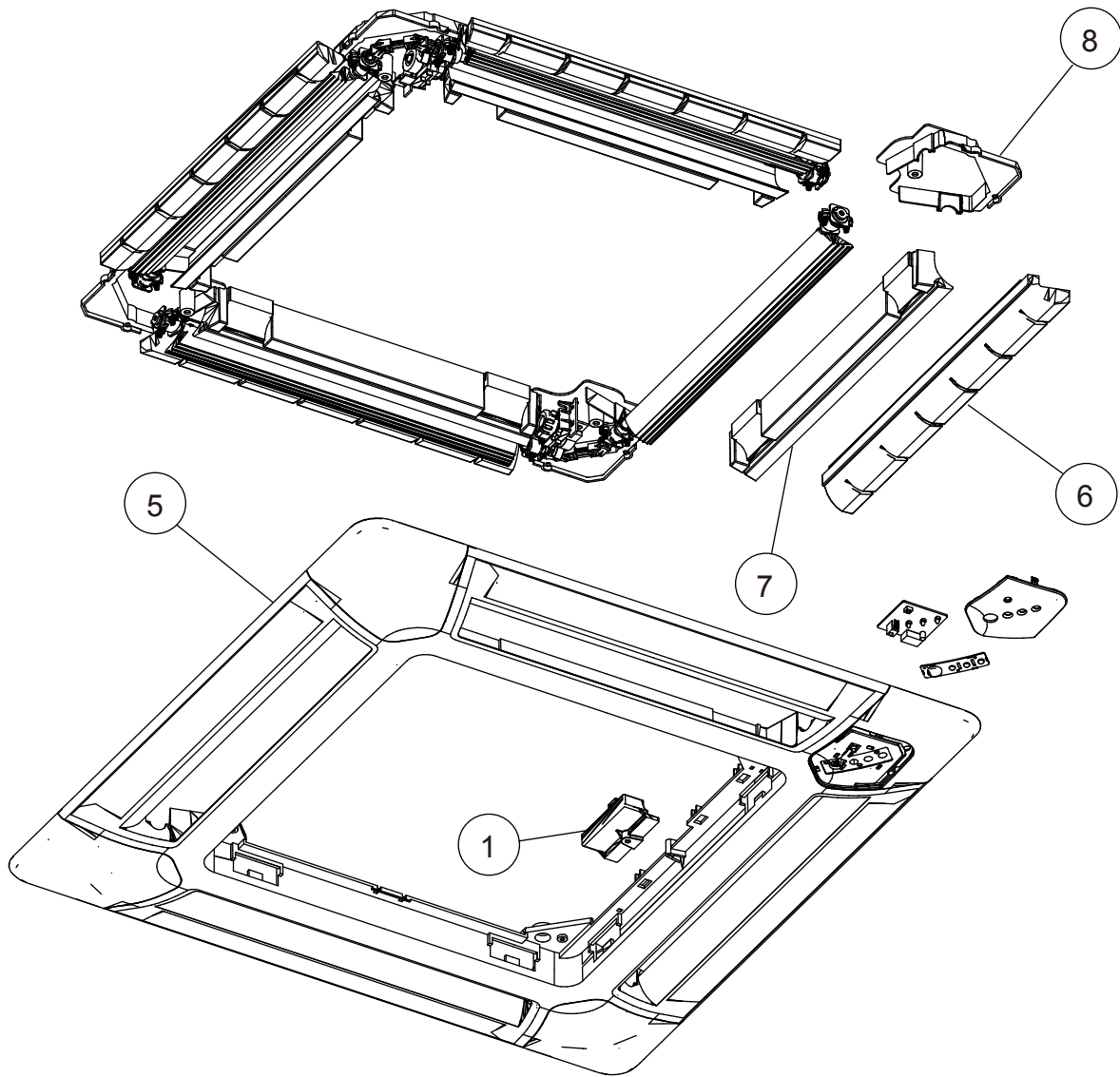

DECORATION PANEL  
UTG-UFYD-W

Ref.	Description	Part number
1	Connector Cover	9375549015
2	Display Panel	9375529123
3	Receiver Window	9375547011
4	Indicator PCB	9707371031
5	Decoration Panel	9375525040
6	Panel Insulation A	9375526016
7	Panel Insulation B	9375527013
8	Panel Cover	9375530013



DECORATION PANEL  
 UTG-UFYD-W  
 Intake grille assy

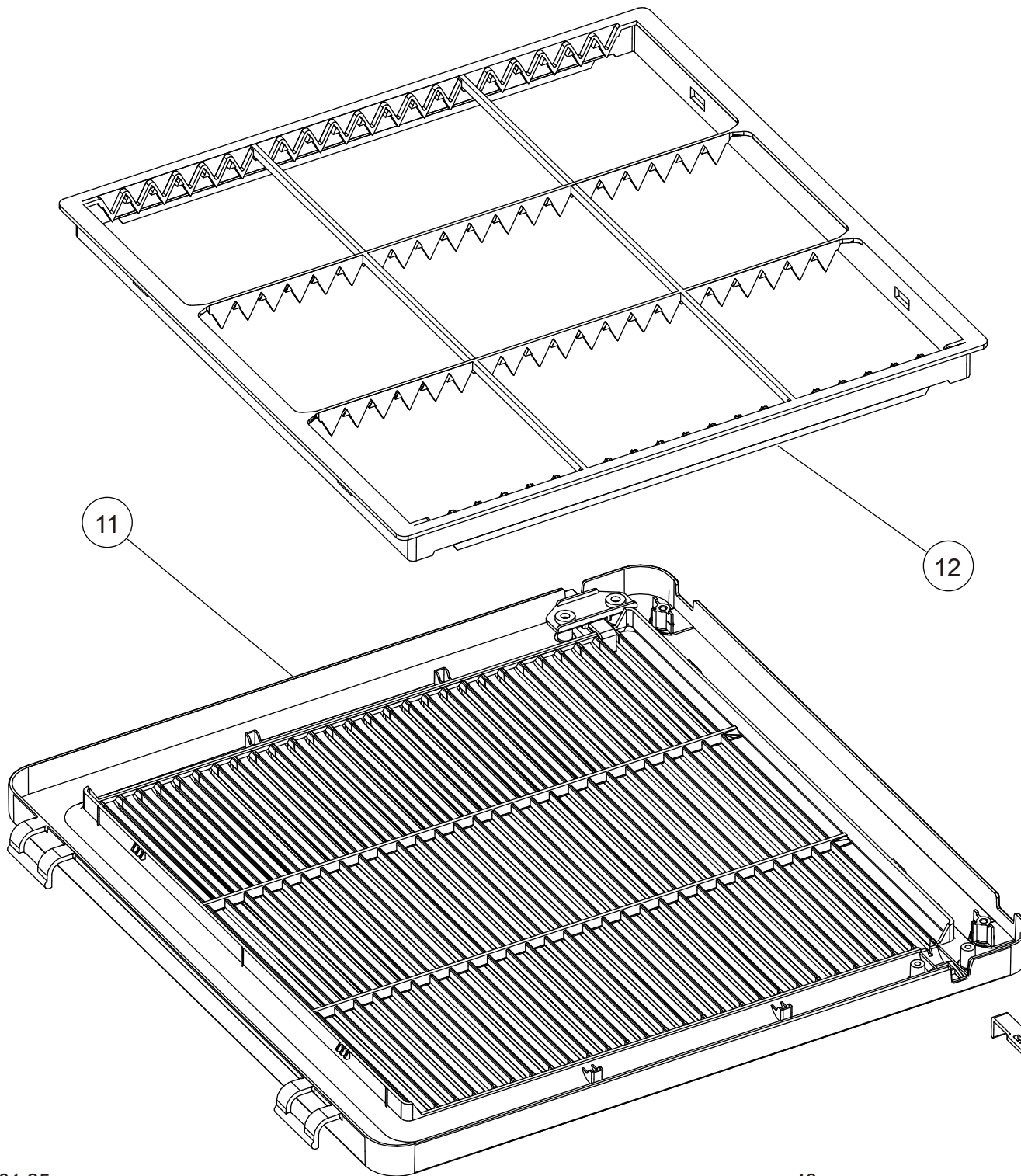

Ref.	Description	Part number	
11	Intake Grille	9375531027	
12	Long Life Filter	9375533014	
13	Hook Bracket	9375546014	
14	Grille Hook	9375532024	



DECORATION PANEL  
 UTG-UFYD-W  
 Flap total assy  
 Motor holder assy

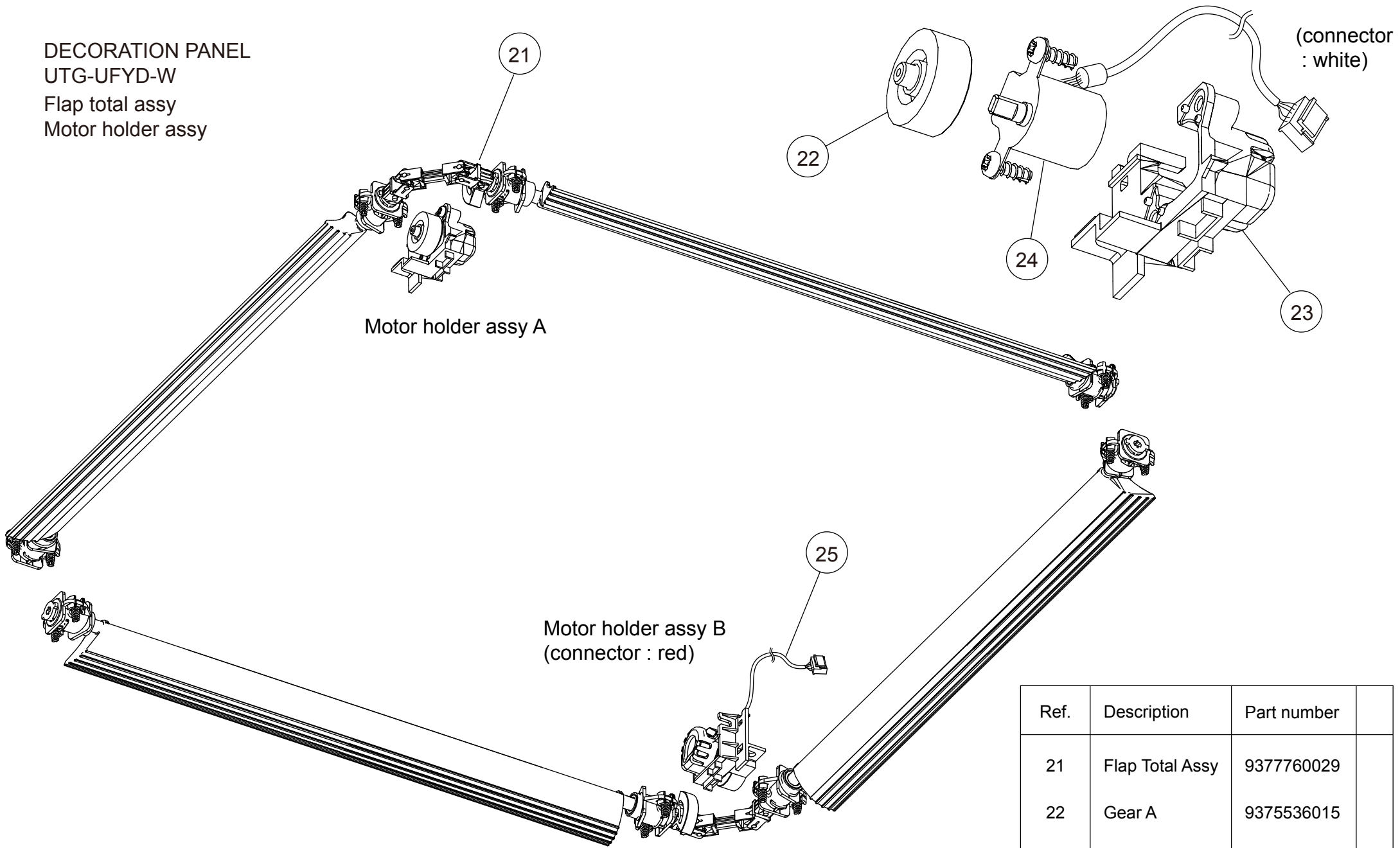

Motor holder assy A

Motor holder assy B  
 (connector : red)

(connector : white)

Ref.	Description	Part number
21	Flap Total Assy	9377760029
22	Gear A	9375536015
23	Motor Holder	9375535018
24	Step Motor	9900139070
25	Step Motor	9900139087

INDOOR UNIT  
CASSETTE  
AUYG18LVLB  
AUYG22LVLA  
AUYG24LVLA

Control Box Cover

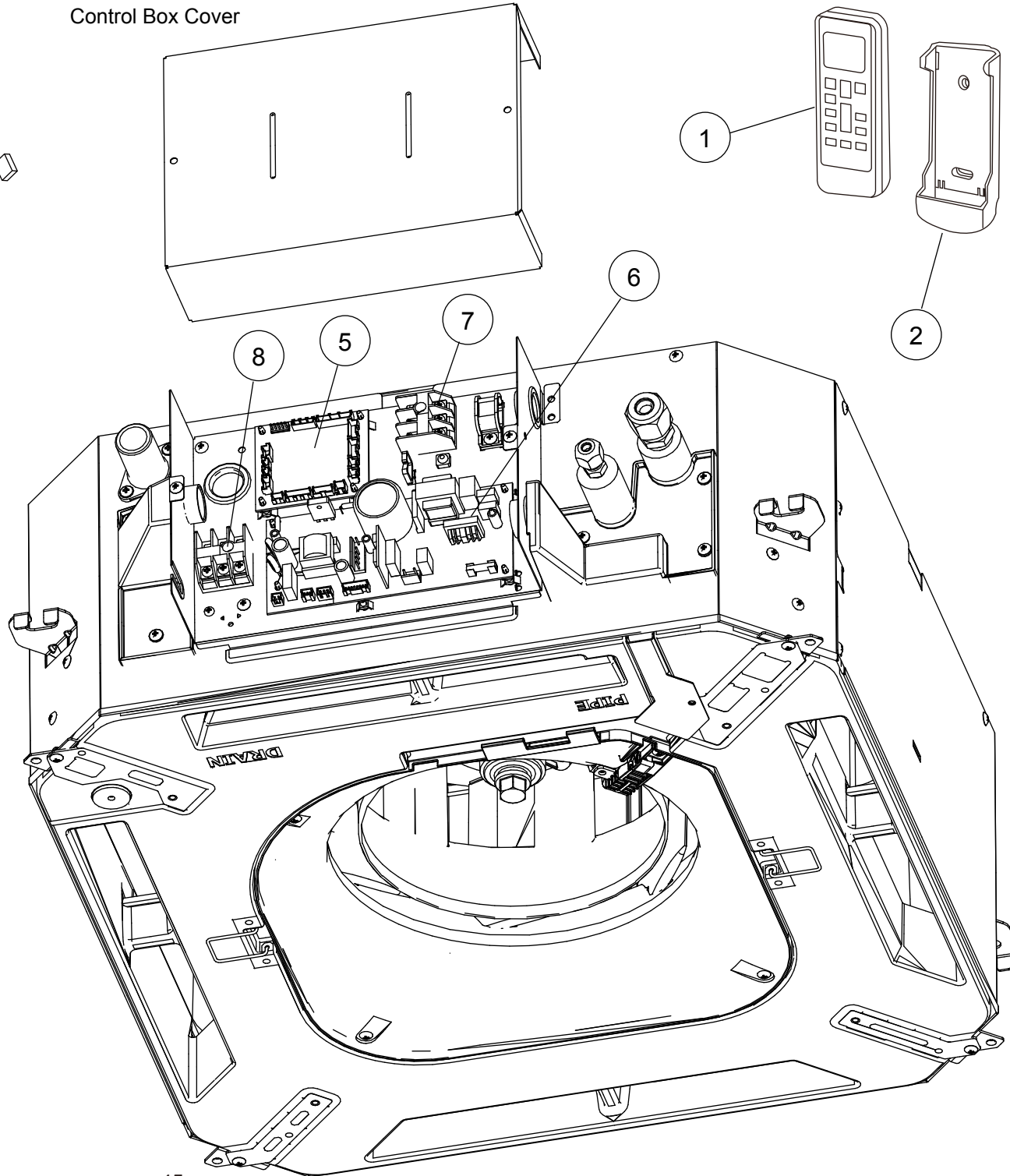
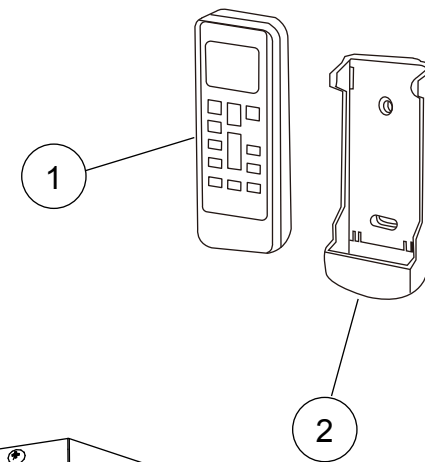
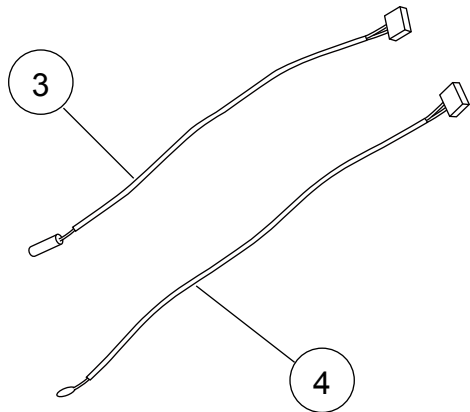

Ref.	Description	Part number
1	Remote Control	9379219006
2	Remote Control Holder	9305642045
3	Pipe Thermistor	9900814007
4	Room Thermistor	9900826000
5	Main PCB (AUYG18)	9709245446
5	Main PCB (AUYG22)	9709245514
5	Main PCB (AUYG24)	9709245453
6	Power Supply PCB	9707398380
7	Terminal	9306489045
8	Terminal	9703345012

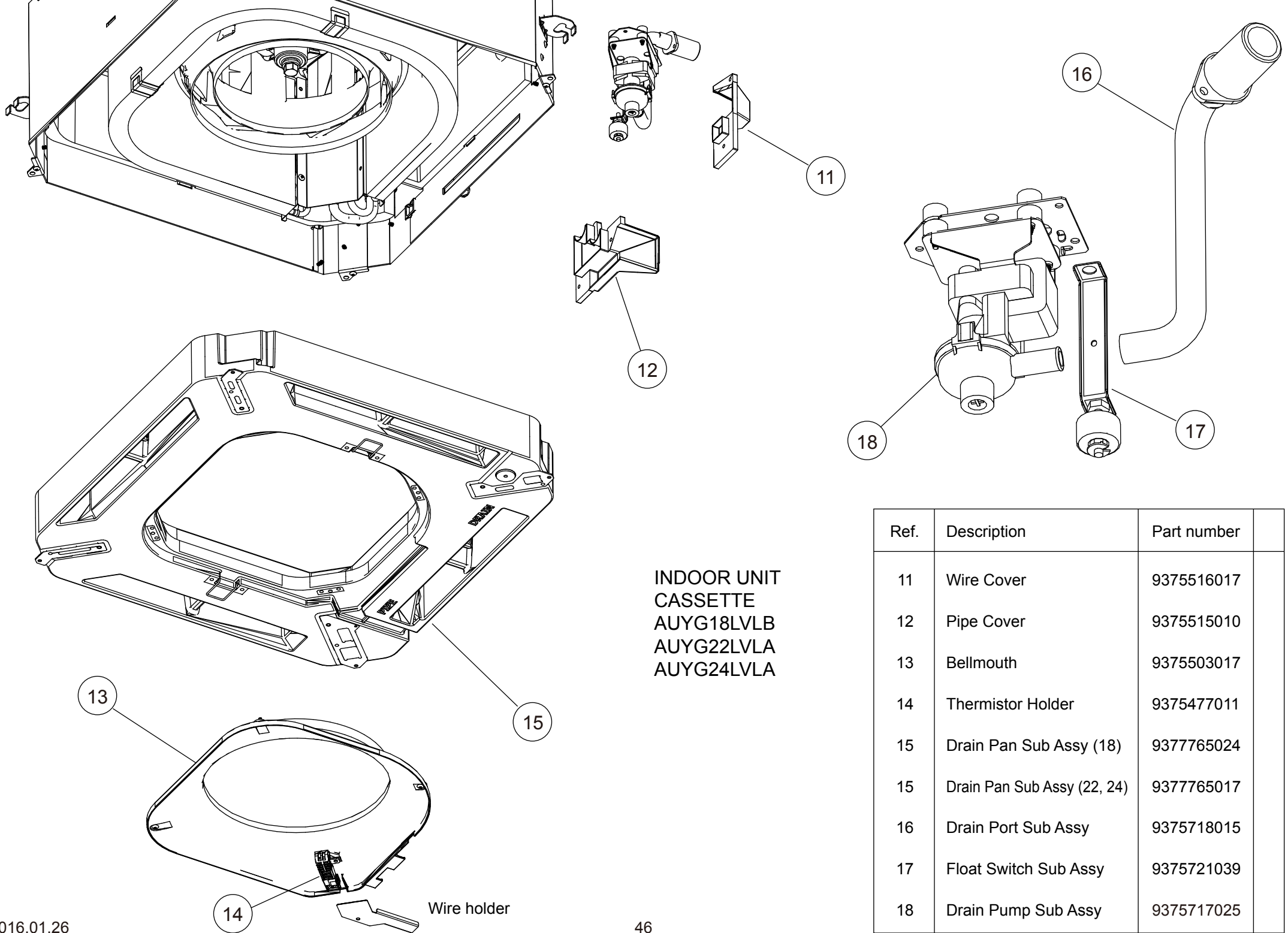

INDOOR UNIT  
CASSETTE  
AUYG18LVLB  
AUYG22LVLA  
AUYG24LVLA

Ref.	Description	Part number
11	Wire Cover	9375516017
12	Pipe Cover	9375515010
13	Bellmouth	9375503017
14	Thermistor Holder	9375477011
15	Drain Pan Sub Assy (18)	9377765024
15	Drain Pan Sub Assy (22, 24)	9377765017
16	Drain Port Sub Assy	9375718015
17	Float Switch Sub Assy	9375721039
18	Drain Pump Sub Assy	9375717025

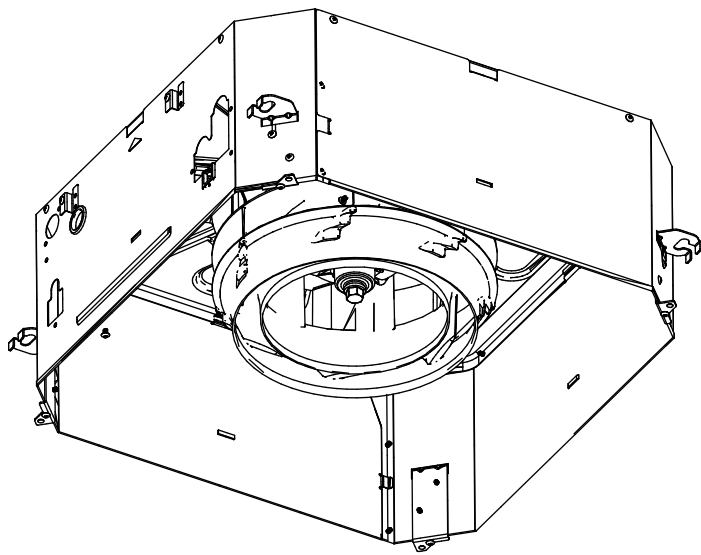

INDOOR UNIT  
CASSETTE  
AUYG18LVLB

AUYG22LVLA  
AUYG24LVLA

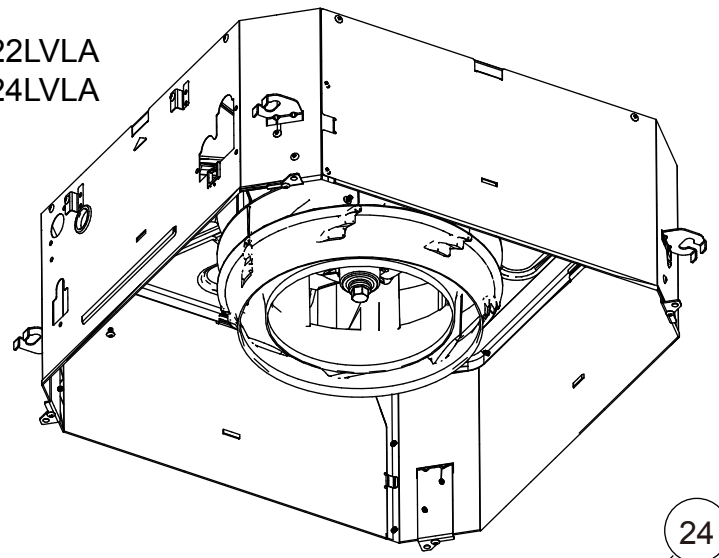

Ref.	Description	Part number
21	Evaporator Total Assy	9377914026
22	Insulation Box Sub Assy	9377764065
23	Evaporator Total Assy	9377914019
24	Insulation Box Sub Assy	9377764058

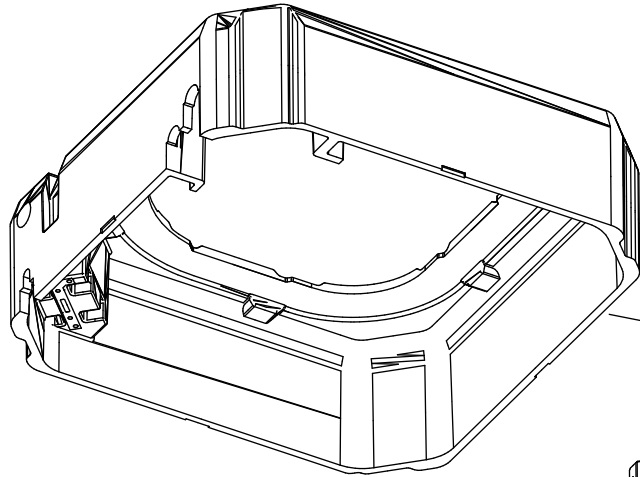

22

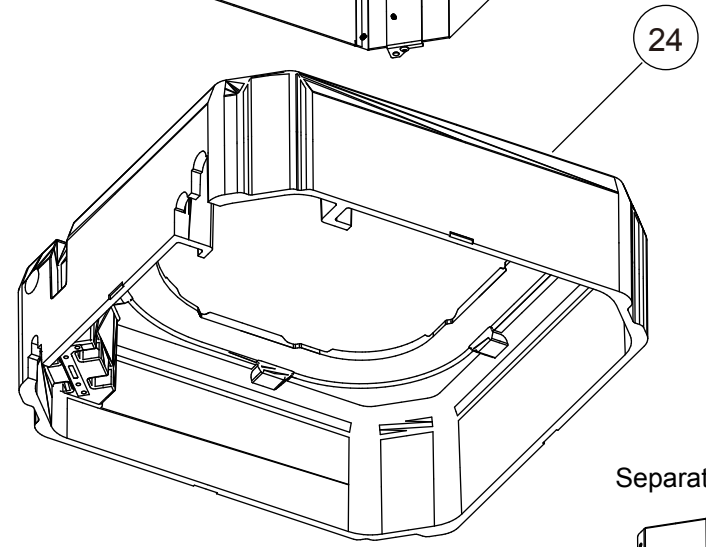

24

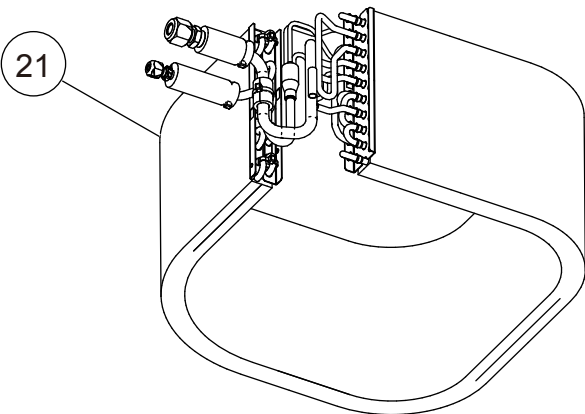

21

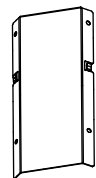

Separate wall



Evaporator holder 2 row

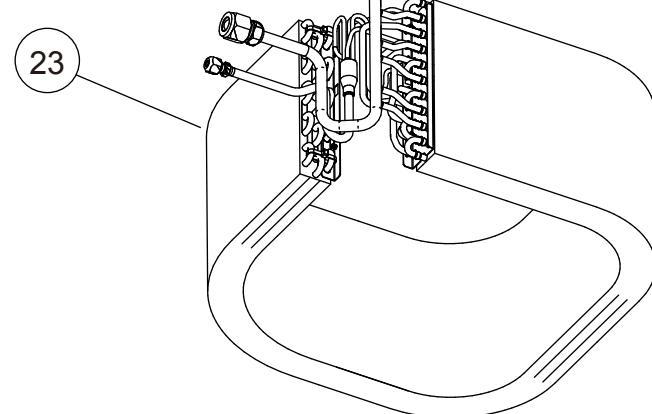
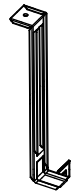

23

Separate wall

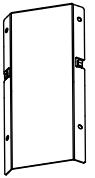

Evaporator holder 3 row



INDOOR UNIT  
CASSETTE  
AUYG18LVLB  
AUYG22LVLA  
AUYG24LVLA

Cabinet B sub assy

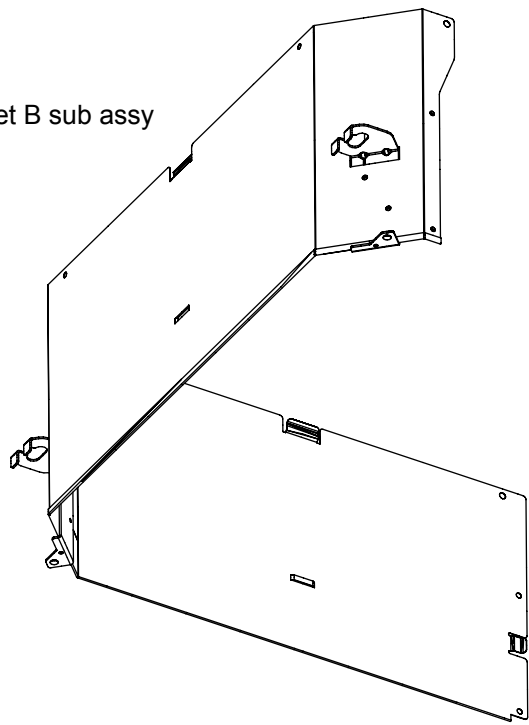

Top plate assy

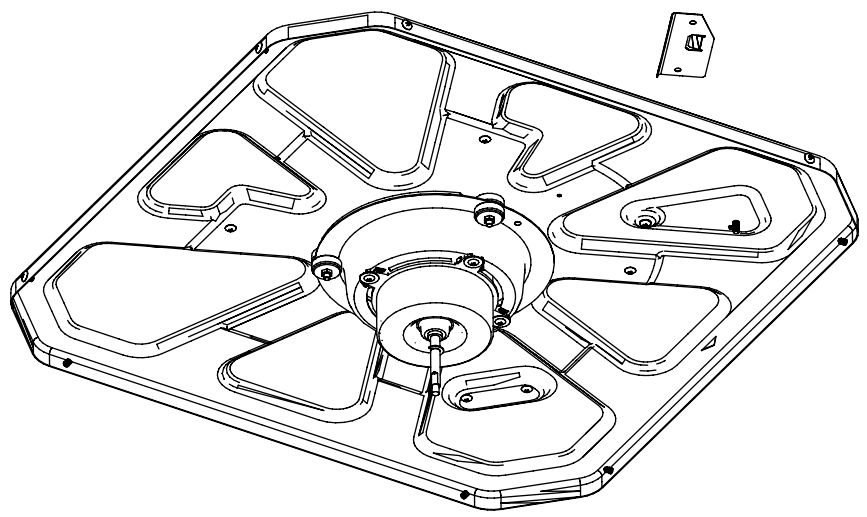

Motor wire holder



Cabinet A sub assy

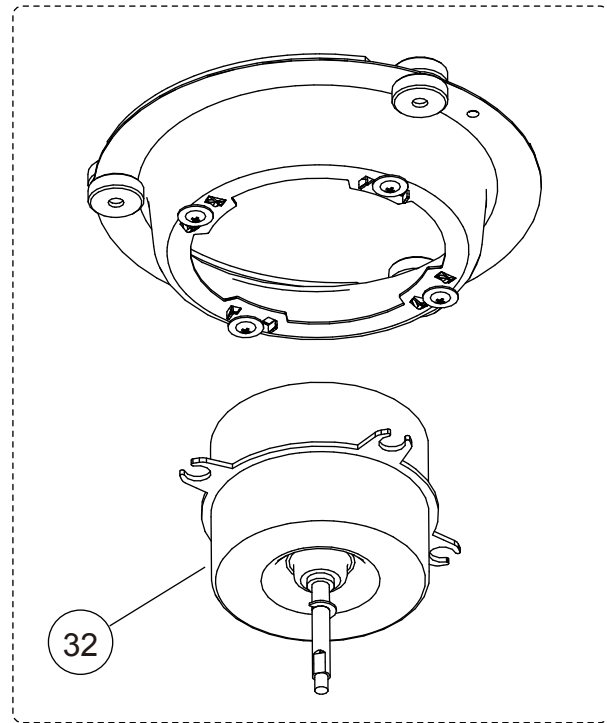
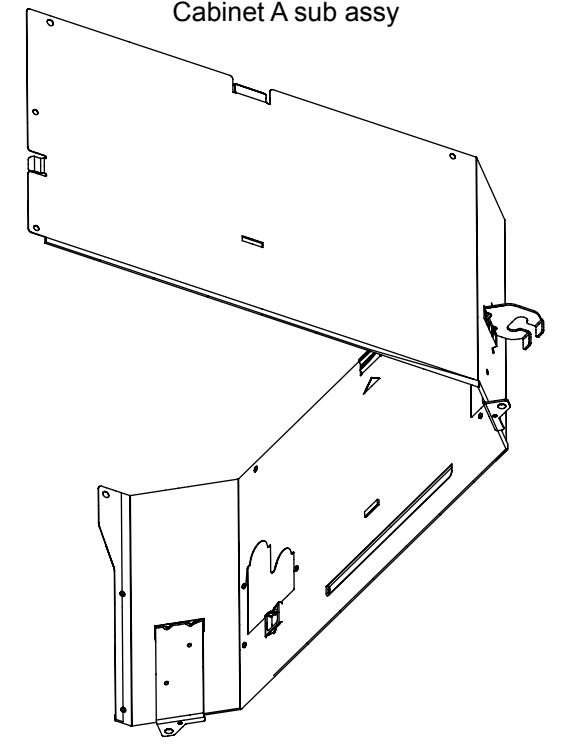

31

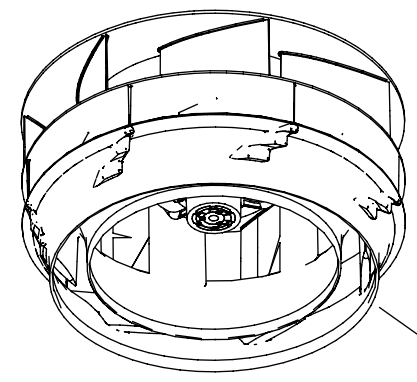

33

Turbo fan washer



35



34

32





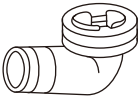









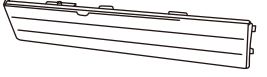

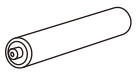
Ref.	Description	Part number
31	Fan Motor Sub Assy	9375719012
32	Fan Motor	9602436019
33	2 Stage Turbo Fan Assy	9375480011
34	Shaft Cap	9377807014
35	Washer Cover	9377811011

## ACCESSORIES

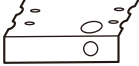
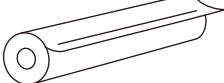
### OUTDOOR UNIT

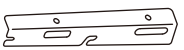

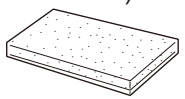
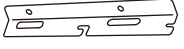

Name and Shape	Q'ty	Use
Drain pipe 	1	For drain piping work 9303029015
Drain cap 	2	313166024302
One-touch bush 	2	For power supply cable and connection cable installation



INDOOR UNIT  
CEILING  
ABYG18LVTB  
ABYG22LVTA  
ABYG24LVTA

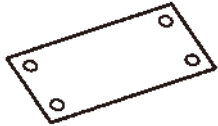

Name and Shape	Q'ty	Name and Shape	Q'ty	Name and Shape	Q'ty	Name and Shape	Q'ty
Cover plate (Left) 	1	Special nut  For suspending the indoor unit from ceiling	4	Binder (Small)  For electrical wiring	2	Remote control 	1
Cover plate (Right) 	1	Wall bracket  For suspending the indoor unit on the wall	2	Wire clammer  For electrical wiring	1	Battery  For remote control	2
Screw (M4 × 10mm) 	2	Screw (M4 × 20mm)  For fixing the wall bracket	6	Drain hose 	1	Remote control holder 	1
Installation template  Positioning for under ceiling type	1	Coupler heat insulator (Large)  For indoor side pipe joint(Large pipe)	1	Hose band  For installing drain hose	1	Screw (M3 × 12mm)  For remote control holder installation	2
Bracket (Left)  For suspending the indoor unit from ceiling	1	Coupler heat insulator (Small)  For indoor side pipe joint (Small pipe)	1	Insulation (Drain hose)  Adhesive type 100 x 220(mm)	1		
Bracket (Right)  For suspending the indoor unit from ceiling	1	Binder (Large)  For fixing drain hose	1	VT wire  For fixing drain hose L 280mm	1		

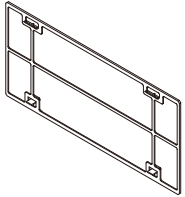
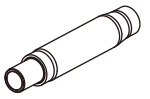

INDOOR UNIT  
SLIM DUCT  
ARYG18LLTB



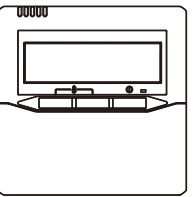

Name and Shape	Q'ty
Installation template 	1
For positioning the indoor unit	
Washer 	8
For installing indoor unit	
Coupler heat insulation (Large) 	1
For indoor side pipe joint	
Coupler heat insulation (Small) 	1
For indoor side pipe joint	
Cable tie (Medium) 	3
For power supply and remote control cable binding	



Name and Shape	Q'ty
Cable tie (Large) 	4
For fixing the coupler heat insulation	
Filter (Large) 	2
Drain hose 	1
For installing drain pipe VP25 (O.D.32 I.D.26)	
Hose band 	1
For installing drain hose	
Drain hose insulation B 	1
Insulates the drain hose	

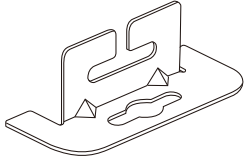
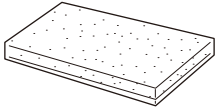

Name and Shape	Q'ty
Wired remote control 	1
Remote control cable 	1
For connecting the remote control	
Tapping screw (M4 x 16 mm) 	2
For installing the remote control	



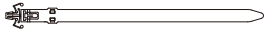
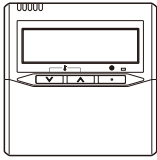
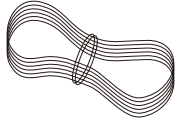





INDOOR UNIT  
DUCT  
ARYG22LMLA  
ARYG24LMLA





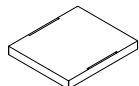
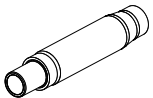

Name and Shape	Q'ty
<p>Hanger</p>  <p>For suspending the indoor unit from ceiling</p>	4
<p>Drain hose insulation</p>  <p>Insulates the drain hose and vinyl hose</p>	1
<p>Cable tie (Large)</p>  <p>For fixing drain hose</p>	1
<p>Cable tie (Small)</p>  <p>For remote control and remote control cable binding</p>	1
<p>Cable tie</p>  <p>For electrical wiring</p>	2

Name and Shape	Q'ty
<p>Wire clammer</p>  <p>For electrical wiring</p>	1
<p>Remote control</p>  <p>For air conditioner operation</p>	1
<p>Remote control cable</p>  <p>For connecting the remote control</p>	1
<p>Screw (M4 × 16)</p>  <p>For installing the remote control</p>	2
<p>Coupler heat insulation (Large)</p>  <p>For indoor side pipe joint (gas)</p>	1

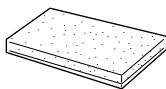

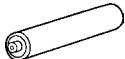

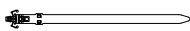

Name and Shape	Q'ty
<p>Coupler heat insulation (Small)</p>  <p>For indoor side pipe joint (liquid)</p>	1
<p>Special nut A (Large flange)</p>  <p>For suspending the indoor unit from ceiling</p>	4
<p>Special nut B (Small flange)</p>  <p>For suspending the indoor unit from ceiling</p>	4

INDOOR UNIT  
CASSETTE  
AUYG18LVLB  
AUYG22LVLA  
AUYG24LVLA

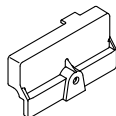
Name and Shape	Q'ty
Coupler heat insulation (Large)  For indoor side pipe joint (gas pipe)	1
Coupler heat insulation (Small)  For indoor side pipe joint (liquid pipe)	1
Special nut A (Large flange)  For installing indoor unit	4
Special nut B (Small flange)  For installing indoor unit	4
Template (Carton top)  For ceiling openings cutting Also used as packing	1
Drain hose  For installing drain pipe	1
Hose Band  For installing drain hose	1

Name and Shape	Q'ty
Drain hose insulation  For installing drain pipe	1
Remote control  1	1
Battery  2	2
Remote control holder  1	1
Tapping screw (M3 × 12mm)  Mounting the remote control holder	2
Cable tie  For electrical wiring	2
Wire clasper  For electrical wiring	1

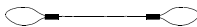
DECORATION PANEL  
UTG-UFYD-W

Name and Shape	Q'ty
Connector cover  For covering connector	1
Tapping Screw (M5 × 12 mm)  Mounting decoration panel	4
Tapping Screw (M4 × 12 mm)  Mounting connector cover	1
L angle  Mounting the Hook Wire to the decoration panel	2
Hook wire  Suspending the decoration panel	2
Screw [pitch small] (M4 × 10 mm)  Mounting the Hook wire (for metals)	2
Screw [pitch large] (M4 × 10 mm)  Mounting the L angle and Hook wire (for resins)	4

1601G4482