

Split type room air conditioner
Wall-mounted type

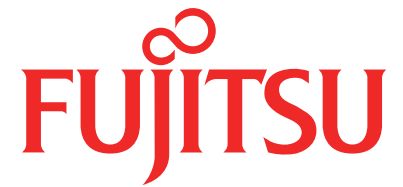

SERVICE MANUAL



| Indoor unit | Outdoor unit |
|-------------|--------------|
| ASYG07KPCA | AOYG07KPCA |
| ASYG09KPCA | AOYG09KPCA |
| ASYG12KPCA | AOYG12KPCA |

CONTENTS

| | |
|--------------------------------|----|
| SPECIFICATIONS..... | 1 |
| DIMENSIONS..... | 4 |
| REFRIGERANT SYSTEM DIAGRAM.... | 7 |
| PCB CIRCUIT DIAGRAM..... | 8 |
| ERROR DETECTION..... | 10 |
| ACCESSORIES..... | 14 |

Specifications

| Type | | | | Wall mounted | | |
|------------------------------|------------------------|--------------------|---|--------------------|--------------|--------------|
| | | | | Inverter heat pump | | |
| Model name | | | | ASYG07KPCA | ASYG09KPCA | ASYG12KPCA |
| Power supply | | | | 230 V ~ 50 Hz | | |
| Power supply intake | | | | Outdoor unit | | |
| Available voltage range | | | | 198—264 V | | |
| Capacity | Cooling | Rated | kW | 2.00 | 2.50 | 3.40 |
| | | | Btu/h | 6,800 | 8,500 | 11,600 |
| | | Min.—Max. | kW | 0.9—2.8 | 0.9—3.0 | 0.9—3.7 |
| | Heating | Rated | Btu/h | 3,100—9,600 | 3,100—10,200 | 3,100—12,600 |
| | | | kW | 2.50 | 2.80 | 3.80 |
| | | Min.—Max. | kW | 0.9—3.4 | 0.9—3.8 | 0.9—4.80 |
| Input power | Cooling | Rated | kW | 0.48 | 0.71 | 1.00 |
| | | | | Min.—Max. | 0.25—1.03 | 0.25—1.05 |
| | | Heating | | Rated | 0.63 | 0.79 |
| | Min.—Max. | | | 0.25—1.39 | 0.25—1.39 | 0.25—1.60 |
| | Fan | | | HIGH | W | 21.5 |
| | | MED | | 12.5 | | 14.5 |
| LOW | | 6.3 | 7.1 | | | |
| QUIET | | 3.0 | 3.0 | | | |
| Current | Cooling | Rated | A | 2.7 | 3.5 | 4.7 |
| | Heating | | | 3.2 | 3.8 | 5.6 |
| EER | Cooling | | kW/kW | 4.17 | 3.52 | 3.40 |
| COP | Heating | | | 3.97 | 3.54 | 3.33 |
| Sensible capacity | Cooling | | kW | 1.9 | 2.1 | 2.6 |
| Power factor | Cooling | | % | 77 | 87 | 92 |
| | Heating | | | 85 | 90 | 89 |
| Moisture removal | | | L/h (pints/h) | 1.0 (1.8) | 1.3 (2.30) | 1.8 (3.20) |
| Maximum operating current *1 | Cooling | | A | 6.5 | 6.5 | 6.5 |
| | Heating | | | 9.0 | 9.0 | 9.0 |
| Fan | Airflow rate | Cooling | m ³ /h | HIGH | 580 | 630 |
| | | | | MED | 460 | 490 |
| | | | | LOW | 340 | 360 |
| | | | | QUIET | 240 | 240 |
| | | Heating | | HIGH | 580 | 630 |
| | | | | MED | 460 | 490 |
| | | | | LOW | 380 | 380 |
| | | | | QUIET | 260 | 260 |
| | Type × Q'ty | Cross flow fan × 1 | | | | |
| | Motor output | | | W | 27 | 27 |
| Sound pressure level *2 | Cooling | dB (A) | HIGH | 45 | 45 | 46 |
| | | | MED | 38 | 38 | 40 |
| | | | LOW | 31 | 31 | 33 |
| | | | QUIET | 22 | 22 | 22 |
| | Heating | | HIGH | 45 | 45 | 46 |
| | | | MED | 40 | 40 | 40 |
| | | | LOW | 36 | 36 | 35 |
| | | | QUIET | 28 | 26 | 27 |
| Heat exchanger type | Dimensions (H × W × D) | | mm | 210 × 600 × 26.6 | | |
| | Fin pitch | | | 1.3 | | |
| | Rows × Stages | | | 2 × 10 | | |
| | Pipe type | | | Copper tube | | |
| | Fin type | | | Aluminum | | |
| Enclosure | Material | | Polystyrene | | | |
| | Color | | White Approximate color of Munsell N 9.25/ | | | |
| Dimensions (H × W × D) | Net | mm | 270 × 784 × 224 | | | |
| | Gross | | 279 × 864 × 334 | | | |
| Weight | Net | kg | 8.0 | | | |
| | Gross | | 11.0 | | | |
| Connection pipe | Size | Liquid | mm (in) | Ø 6.35 (1/4) | | |
| | | Gas | | Ø 9.52 (3/8) | | |
| | Method | Flare | | | | |
| Drain hose | Material | | PP+HDPE | | | |
| | Size | mm | Ø 11.8 (I.D.), Ø 15 to Ø 16.8 (O.D.) | | | |
| Operation range | Cooling | | °C | 18 to 32 | | |
| | Heating | | %RH | 80 or less | | |
| Remote controller type | | | °C | 16 to 30 | | |
| | | | | Wireless | | |

NOTES:

- Specifications are based on the following conditions:
 - Cooling: Indoor temperature of 27 °CDB/19 °CWB, and outdoor temperature of 35 °CDB/24 °CWB.
 - Heating: Indoor temperature of 20 °CDB/15 °CWB, and outdoor temperature of 7 °CDB/6 °CWB.
 - Pipe length: 5 m, Height difference: 0 m. (Between outdoor unit and indoor unit.)
- Protective function might work when using it outside the operation range.
- *1: Maximum current is maximum value when operated within the operation range.
- *2: Sound pressure level:
 - Measured values in manufacturer's anechoic chamber.
 - Because of the surrounding sound environment, the sound levels measured in actual installation conditions might be higher than the specified values here.

| Specifications for Lot10 | | | | | |
|---------------------------|-------------------|---------|-----------------|--------------|--------------|
| Model name | | | ASYG07KPCA | ASYG09KPCA | ASYG12KPCA |
| Energy efficiency class | Cooling | | A ⁺⁺ | | |
| | Heating (Average) | | A ⁺ | | |
| P design | Cooling | kW | 2.0 (35 °C) | 2.5 (35 °C) | 3.4 (35 °C) |
| | Heating (Average) | | 2.2 (-10 °C) | 2.4 (-10 °C) | 2.5 (-10 °C) |
| SEER | Cooling | kWh/kWh | 6.7 | 6.7 | 6.3 |
| SCOP | Heating (Average) | | 4.0 | 4.0 | 4.1 |
| Annual energy consumption | QCE | kWh/a | 104 | 131 | 189 |
| | QHE (Average) | | 769 | 840 | 853 |
| Sound power level | Cooling | HIGH | dB (A) | 57 | 58 |
| | Heating | | | 58 | 58 |

| Type | | | | Inverter heat pump | | | |
|-------------------------|---------------------------------|-------------------|--|--|------------|------------------|-----|
| Model name | | | | AOYG07KPCA | AOYG09KPCA | AOYG12KPCA | |
| Power supply | | | | 230 V ~ 50 Hz | | | |
| Power supply intake | | | | Outdoor unit | | | |
| Available voltage range | | | | 198—264 V | | | |
| Starting current | | | | A | 3.2 | 3.8 | 5.6 |
| Fan | Airflow rate | Cooling | m ³ /h | 1,650 | 1,650 | 1,700 | |
| | | Heating | | 1,450 | 1,450 | 1,470 | |
| | Type × Q'ty | Propeller fan × 1 | | | | | |
| Motor output | | | | W | 23 | | |
| Sound pressure level *1 | | Cooling | dB (A) | 45 | 47 | 49 | |
| | | Heating | | 46 | 47 | 51 | |
| Sound power level | | Cooling | dB (A) | 57 | 59 | 62 | |
| | | Heating | | 58 | 59 | 62 | |
| Heat exchanger type | Dimensions (H × W × D) | | mm | 504 × 650 × 18.2 | | 504 × 630 × 36.4 | |
| | Fin pitch | | | 1.3 | | | |
| | Rows × Stages | | 1 × 24 | | 2 × 24 | | |
| | Pipe type | | Copper | | | | |
| | Fin type | | Type (Material) | Corrugate (Aluminum) | | | |
| | | Surface treatment | PC Fin | | | | |
| Compressor | Type × Q'ty | | DC Rotary × 1 | | | | |
| | Motor output | | W | 850 | | | |
| Refrigerant | Type (Global warming potential) | | R32 (675) | | | | |
| | Charge | | g | 550 | 590 | | |
| Refrigerant oil | Type | | POE | | | | |
| | Amount | | cm ³ | 240 | | | |
| Enclosure | Material | | Steel sheet | | | | |
| | Color | | Beige Approximate color of Munsell 10YR 7.5/1.0 | | | | |
| Dimensions (H × W × D) | Net | | mm | 541 × 663 × 290 | | | |
| | Gross | | | 596 × 798 × 369 | | | |
| Weight | Net | | kg | 23 | | 25 | |
| | Gross | | | 25 | | 27 | |
| Connection pipe | Size | Liquid | mm (in) | Ø 6.35 (1/4) | | | |
| | | Gas | | Ø 9.52 (3/8) | | | |
| | Method | | Flare | | | | |
| | Pre-charge length | | m | 15 | | | |
| | Max. length | | | 20 | | | |
| Max. height difference | | 15 | | | | | |
| Operation range | | Cooling | °C | -10 to 46 | | | |
| | | Heating | | -15 to 24 | | | |
| Drain hose | Material | | PP | | | | |
| | Size | | mm | Ø 13.0 (I. D.), Ø 16.0 to Ø 16.8 (O. D.) | | | |

NOTES:

- Specifications are based on the following conditions:
 - Cooling: Indoor temperature of 27 °CDB/19 °CWB, and outdoor temperature of 35 °CDB/24 °CWB.
 - Heating: Indoor temperature of 20 °CDB/15 °CWB, and outdoor temperature of 7 °CDB/6 °CWB.
 - Pipe length: 5 m, Height difference: 0 m.
- Protective function might work when using it outside the operation range.
- *1: Sound pressure level
 - Measured values in manufacturer's anechoic chamber.
 - Because of the surrounding sound environment, the sound levels measured in actual installation conditions might be higher than the specified values here.

Dimensions

Models: ASYG07KPCA, ASYG09KPCA, and ASYG12KPCA

Unit: mm

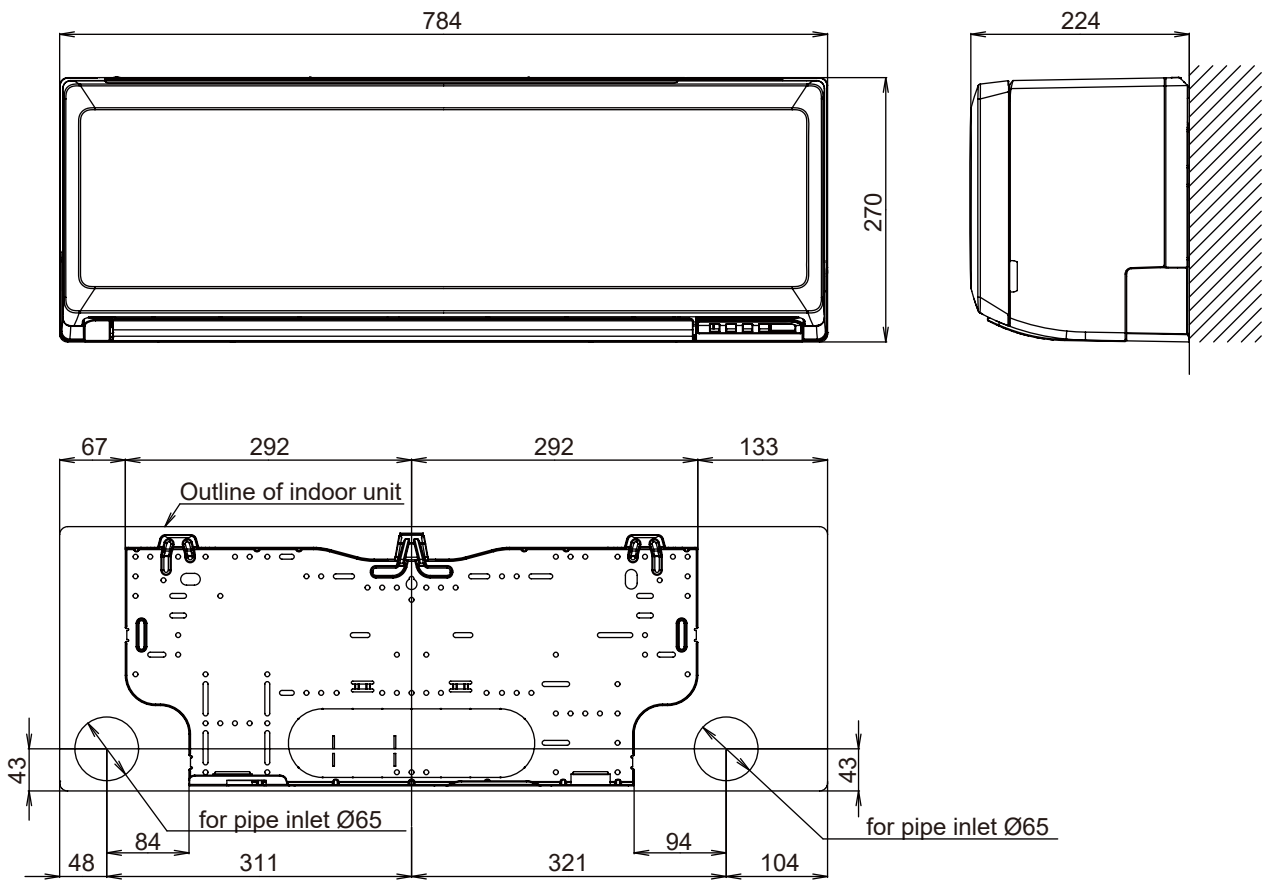

■ Installation space requirement

Provide sufficient installation space for product safety.

Unit: mm

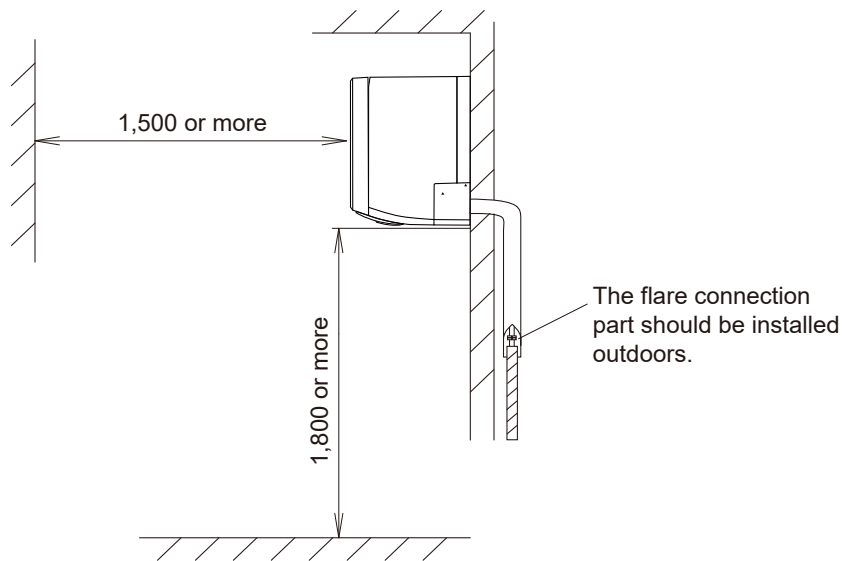
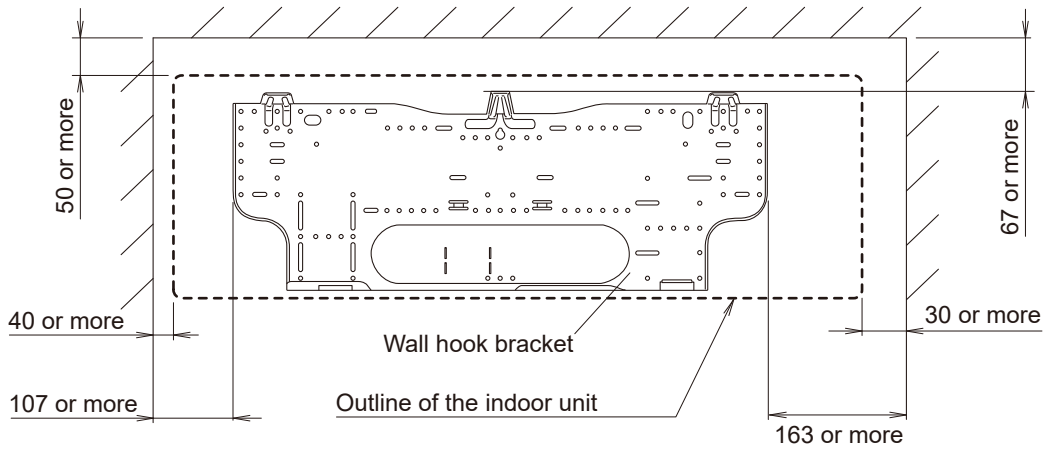

Models: AOYG07KPCA, AOYG09KPCA, and AOYG12KPCA

Unit: mm

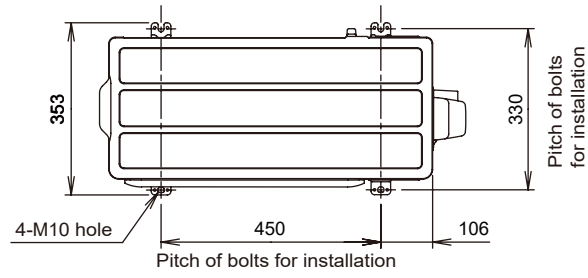

Top view

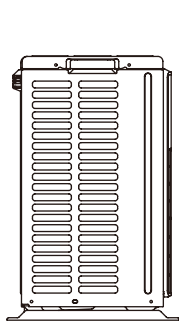

Side view

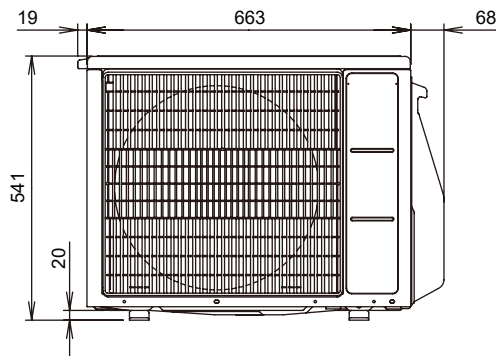

Front view

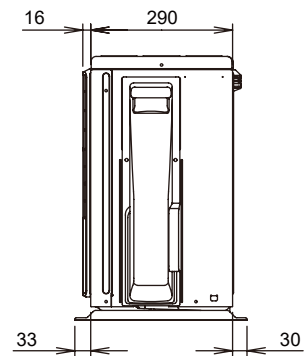

Side view

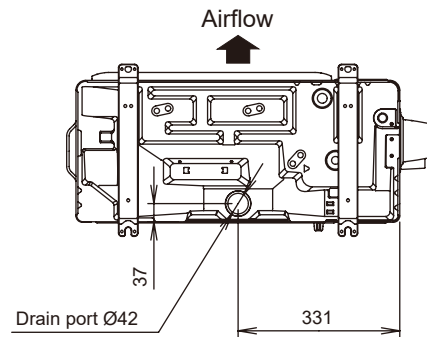

Bottom view

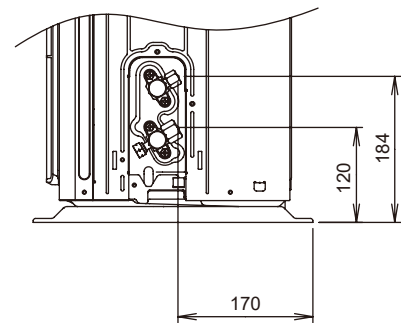

Side view (Bulb part)

Refrigerant circuit

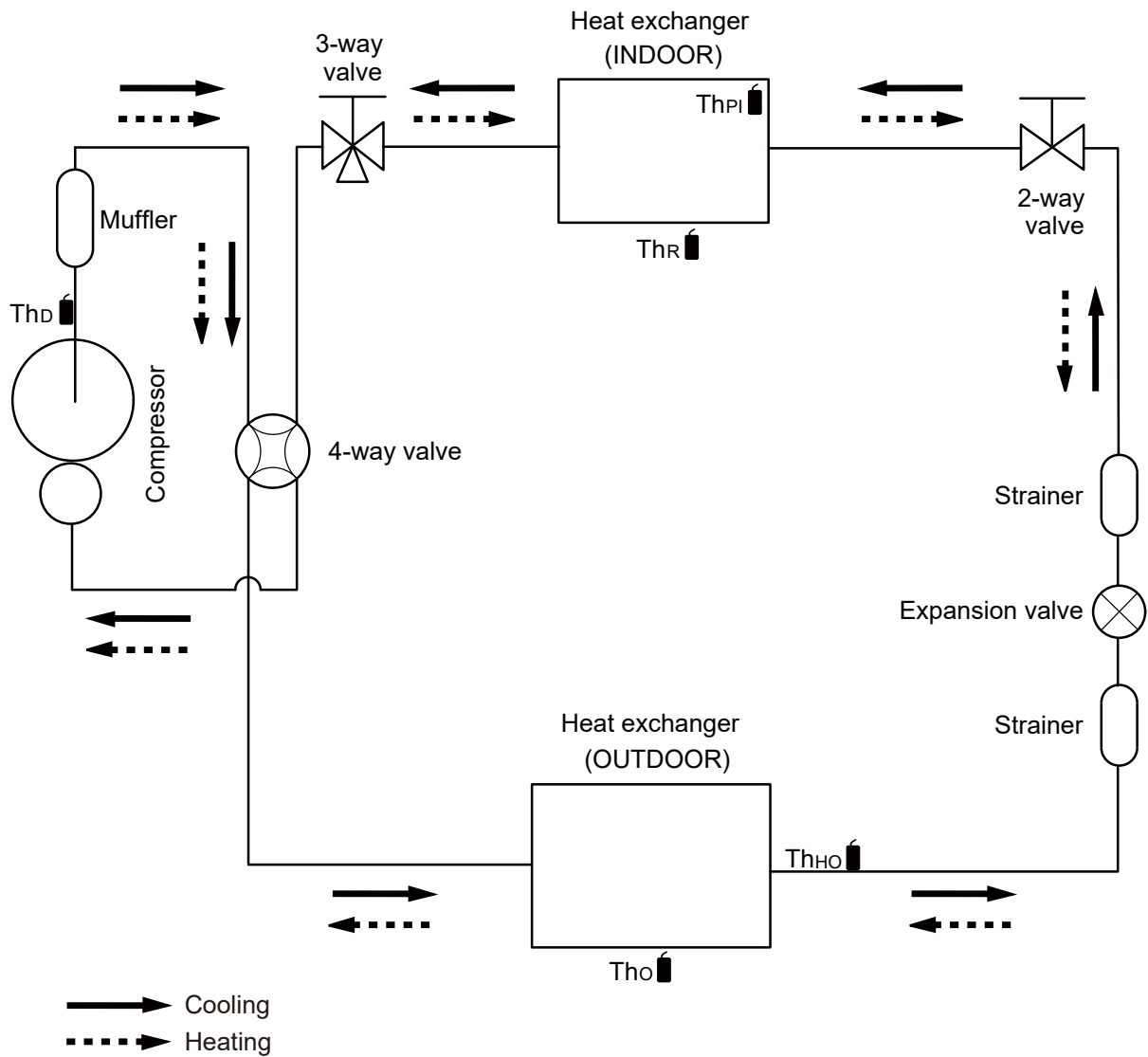

- Th_D : Thermistor (Discharge temperature)
- Th_O : Thermistor (Outdoor temperature)
- Th_{HO} : Thermistor (Heat exchanger out temperature)
- Th_R : Thermistor (Room temperature)
- Th_{PI} : Thermistor (Pipe temperature)

PCB circuit diagram

Models : ASYG07KPCA
 ASYG09KPCA
 ASYG12KPCA

CONTROL UNIT
 ASYG07KPCA : EZ-0180BHSE
 ASYG09KPCA : EZ-0180CHSE
 ASYG12KPCA : EZ-0180DHSE

CN5 DC Fan motor

| Pin No. | Terminal code | Function of terminal | Lead wire color |
|---------|---------------|-----------------------------|-----------------|
| 1 | Vm | Motor power voltage input | Red |
| 2 | --- | --- | --- |
| 3 | --- | --- | --- |
| 4 | GND | GND | Black |
| 5 | Vcc | Control power voltage input | White |
| 6 | Vsp | Speed control voltage input | Yellow |
| 7 | FG | Revolution pulse output | Blue |

CN1 Thermistor Characteristics.

| Thermistor | Temperature | | |
|---------------------------|--------------------|-------------------|-------------------|
| | (0°C) | (20°C) | (30°C) |
| Thermistor (Pipe temp.) | 176.0 k Ω 1.1 V | 62.9 k Ω 2.2 V | 39.6 k Ω 2.8 V |
| Thermistor (Room temp.) | 33.6 k Ω 1.1 V | 12.5 k Ω 2.2 V | 8.0 k Ω 2.8 V |

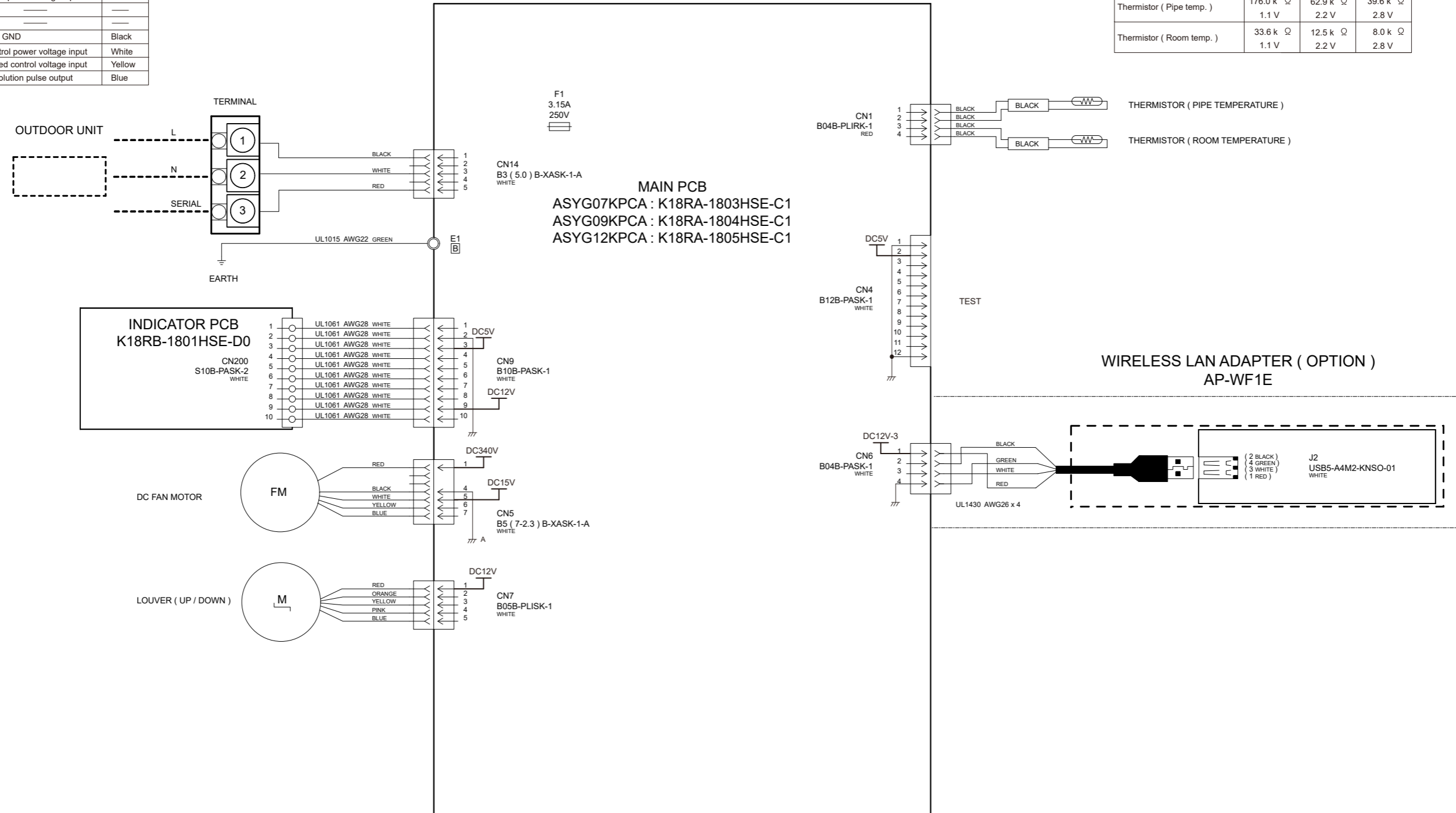

Models : AOYG07KPCA
 AOYG09KPCA
 AOYG12KPCA

INVERTER ASSEMBLY
 AOYG07KPCA : EZ-018GHUE
 AOYG09KPCA : EZ-018HHUE
 AOYG12KPCA : EZ-018KHUE

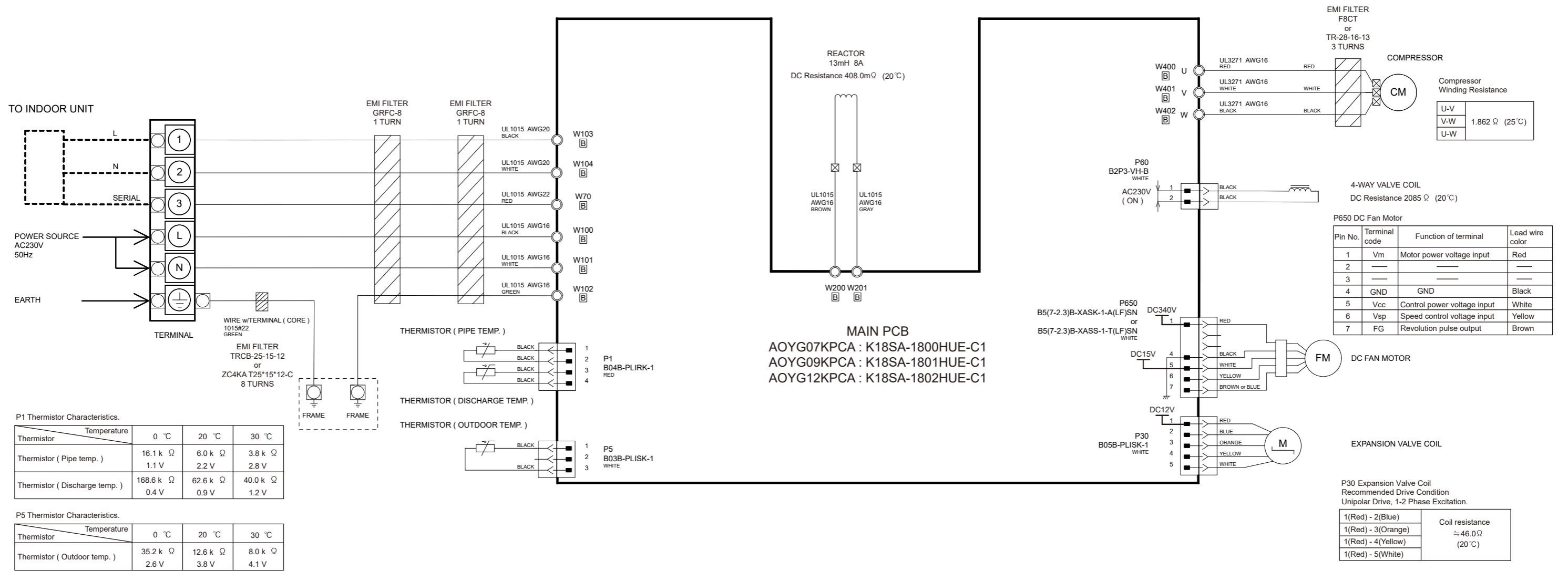

P1 Thermistor Characteristics.

| Thermistor | Temperature | 0 °C | 20 °C | 30 °C |
|--------------------------------|-------------|-----------|----------|----------|
| Thermistor (Pipe temp.) | | 16.1 k Ω | 6.0 k Ω | 3.8 k Ω |
| | | 1.1 V | 2.2 V | 2.8 V |
| Thermistor (Discharge temp.) | | 168.6 k Ω | 62.6 k Ω | 40.0 k Ω |
| | | 0.4 V | 0.9 V | 1.2 V |

P5 Thermistor Characteristics.

| Thermistor | Temperature | 0 °C | 20 °C | 30 °C |
|------------------------------|-------------|----------|----------|---------|
| Thermistor (Outdoor temp.) | | 35.2 k Ω | 12.6 k Ω | 8.0 k Ω |
| | | 2.6 V | 3.8 V | 4.1 V |

Compressor Winding Resistance

| | |
|-----|----------------|
| U-V | |
| V-W | 1.862 Ω (25°C) |
| U-W | |

P650 DC Fan Motor

| Pin No. | Terminal code | Function of terminal | Lead wire color |
|---------|---------------|-----------------------------|-----------------|
| 1 | Vm | Motor power voltage input | Red |
| 2 | | | |
| 3 | | | |
| 4 | GND | GND | Black |
| 5 | Vcc | Control power voltage input | White |
| 6 | Vsp | Speed control voltage input | Yellow |
| 7 | FG | Revolution pulse output | Brown |

P30 Expansion Valve Coil Recommended Drive Condition Unipolar Drive, 1-2 Phase Excitation.

| | |
|--------------------|---------------------------------------|
| 1(Red) - 2(Blue) | Coil resistance ≈ 46.0 Ω (20°C) |
| 1(Red) - 3(Orange) | |
| 1(Red) - 4(Yellow) | |
| 1(Red) - 5(White) | |

Error detection

If you use a wireless remote controller, the lamp on the photo detector unit will output error codes by way of blinking patterns. If you use a wired remote controller, error codes will appear on the remote control display. See the lamp blinking patterns and error codes in the table. An error display is displayed only during operation.

[Troubleshooting with the indoor unit display]

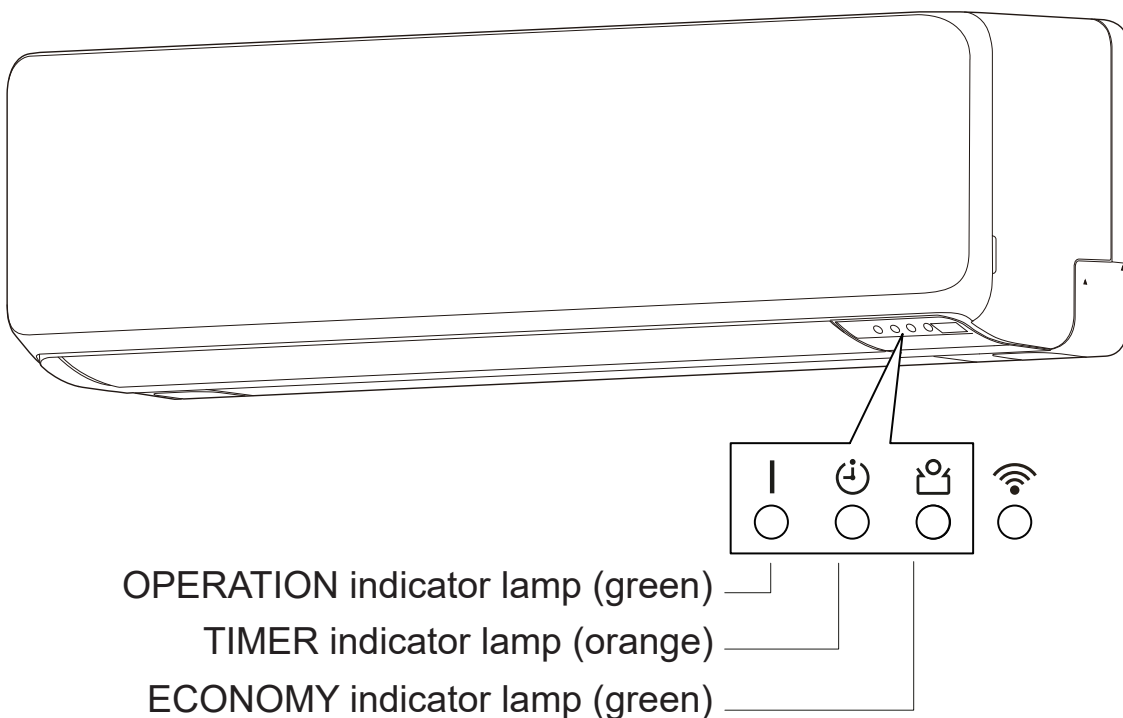

| Error display | | | Error code | Description |
|------------------------|---------------------|----------------------|------------|--|
| OPERATION lamp (green) | TIMER lamp (orange) | ECONOMY lamp (green) | | |
| ●(1) | ●(1) | ◇ | 11 | Serial communication error |
| ●(1) | ●(2) | ◇ | 12 | <ul style="list-style-type: none"> • Wired remote controller communication error • Server room control communication error |
| ●(1) | ●(5) | ◇ | 15 | Check run unfinished Automatic airflow adjustment error |
| ●(1) | ●(8) | ◇ | 18 | External communication error |
| ●(2) | ●(2) | ◇ | 22 | Indoor unit capacity error |
| ●(2) | ●(3) | ◇ | 23 | Combination error |
| ●(2) | ●(6) | ◇ | 26 | Indoor unit address setting error |
| ●(2) | ●(9) | ◇ | 29 | Connection unit number error in wired remote controller system |
| ●(3) | ●(1) | ◇ | 31 | Power supply interruption error |
| ●(3) | ●(2) | ◇ | 32 | Indoor unit PCB model information error |
| ●(3) | ●(3) | ◇ | 33 | Indoor unit motor electricity consumption detection error |
| ●(3) | ●(5) | ◇ | 35 | Manual auto switch error |
| ●(3) | ●(9) | ◇ | 39 | Indoor unit power supply error for fan motor |
| ●(3) | ●(10) | ◇ | 3A | Indoor unit communication circuit (wired remote controller) error |
| ●(4) | ●(1) | ◇ | 41 | Room temp. sensor error |

Display mode ● : 0.5s ON / 0.5s OFF
◇ : 0.1s ON / 0.1s OFF
() : Number of flashing





| Error display | | | Error code | Description |
|------------------------|---------------------|----------------------|------------|--|
| OPERATION lamp (green) | TIMER lamp (orange) | ECONOMY lamp (green) | | |
| ●(4) | ●(2) | ◇ | 42 | Indoor unit heat ex. middle temp. sensor error |
| ●(5) | ●(1) | ◇ | 51 | Indoor unit fan motor error |
| ●(5) | ●(15) | ◇ | 5U | Indoor unit error |
| ●(6) | ●(2) | ◇ | 62 | Outdoor unit main PCB model information error or communication error |
| ●(6) | ●(3) | ◇ | 63 | Inverter error |
| ●(6) | ●(4) | ◇ | 64 | Active filter error, PFC circuit error |
| ●(6) | ●(5) | ◇ | 65 | Trip terminal L error |
| ●(6) | ●(8) | ◇ | 68 | Outdoor unit rush current limiting resistor temp. rise error |
| ●(6) | ●(10) | ◇ | 6A | Display PCB microcomputers communication error |
| ●(7) | ●(1) | ◇ | 71 | Discharge temp. sensor error |
| ●(7) | ●(2) | ◇ | 72 | Compressor temp. sensor error |
| ●(7) | ●(3) | ◇ | 73 | Outdoor unit Heat Ex. liquid temp. sensor error |
| ●(7) | ●(4) | ◇ | 74 | Outdoor temp. sensor error |
| ●(7) | ●(5) | ◇ | 75 | Suction Gas temp. sensor error |
| ●(7) | ●(6) | ◇ | 76 | • 2-way valve temp. sensor error • 3-way valve temp. sensor error |
| ●(7) | ●(7) | ◇ | 77 | Heat sink temp. sensor error |

Display mode ● : 0.5s ON / 0.5s OFF
◇ : 0.1s ON / 0.1s OFF
() : Number of flashing

| Error display | | | Error code | Description |
|------------------------|---------------------|----------------------|------------|--|
| OPERATION lamp (green) | TIMER lamp (orange) | ECONOMY lamp (green) | | |
| ●(8) | ●(2) | ◇ | 82 | <ul style="list-style-type: none"> • Sub-cool Heat Ex. gas inlet temp. sensor error • Sub-cool Heat Ex. gas outlet temp. sensor error |
| ●(8) | ●(3) | ◇ | 83 | Liquid pipe temp. sensor error |
| ●(8) | ●(4) | ◇ | 84 | Current sensor error |
| ●(8) | ●(6) | ◇ | 86 | <ul style="list-style-type: none"> • Discharge pressure sensor error • Suction pressure sensor error • High pressure switch error |
| ●(9) | ●(4) | ◇ | 94 | Trip detection |
| ●(9) | ●(5) | ◇ | 95 | Compressor rotor position detection error (permanent stop) |
| ●(9) | ●(7) | ◇ | 97 | Outdoor unit fan motor 1 error |
| ●(9) | ●(8) | ◇ | 98 | Outdoor unit fan motor 2 error |
| ●(9) | ●(9) | ◇ | 99 | 4-way valve error |
| ●(10) | ●(1) | ◇ | A1 | Discharge temp. error |
| ●(10) | ●(3) | ◇ | A3 | Compressor temp. error |
| ●(10) | ●(4) | ◇ | A4 | High pressure error |
| ●(10) | ●(5) | ◇ | A5 | Low pressure error |

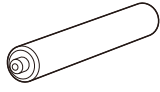

Display mode ● : 0.5s ON / 0.5s OFF
◇ : 0.1s ON / 0.1s OFF
() : Number of flashing

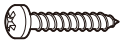
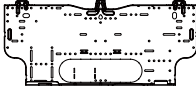
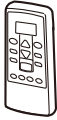
Accessories

| Part name | Exterior | Q'ty | Part name | Exterior | Q'ty |
|---------------------------|---|------|-------------------|---|------|
| Operating manual |  | 1 | Battery |  | 2 |
| Operating manual (CD-ROM) |  | 1 | Cloth tape |  | 1 |
| Installation manual |  | 1 | Tapping screw |  | 5 |
| Wall hook bracket |  | 1 | Remote controller |  | 1 |

| Part name | Exterior | Q'ty | Part name | Exterior | Q'ty |
|------------|---|------|-----------|----------|------|
| Drain pipe |  | 1 | | | |

Optional parts

| Exterior | Part name | Model name | Summary |
|---|--------------------------|------------|--|
|  | Remote controller holder | UTZ-RXLA | Wall or pillar mountable, and holds the wireless remote controller. |
|  | Wireless LAN adapter | UTY-TFSXF2 | Remotely manage an air conditioning system using mobile devices such as smartphones and tablets. |

1902G4797