

# AIR CONDITIONER

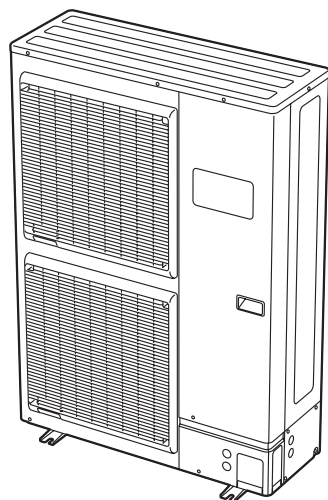

## INSTALLATION MANUAL

OUTDOOR UNIT

For authorized service personnel only.

English

## INSTALLATIONSANLEITUNG

AUSSENGERÄT

Nur für autorisiertes Fachpersonal.

Deutsch

## MANUEL D'INSTALLATION

APPAREIL EXTÉRIEUR

Pour le personnel d'entretien autorisé uniquement.

Français

## MANUAL DE INSTALACIÓN

UNIDAD EXTERIOR

Únicamente para personal de servicio autorizado.

Español

## MANUALE DI INSTALLAZIONE

UNITÀ ESTERNA

A uso esclusivo del personale tecnico autorizzato.

Italiano

## ΕΓΧΕΙΡΙΔΙΟ ΕΓΚΑΤΑΣΤΑΣΗΣ

ΕΞΩΤΕΡΙΚΗ ΜΟΝΑΔΑ

Μόνο για εξουσιοδοτημένο τεχνικό προσωπικό.

Ελληνικά

## MANUAL DE INSTALAÇÃO

UNIDADE EXTERIOR

Apenas para pessoal de assistência autorizado.

Português

## РУКОВОДСТВО ПО УСТАНОВКЕ

ВНЕШНИЙ МОДУЛЬ

Только для авторизованного обслуживающего персонала.

Русский

## MONTAJ KILAVUZU

DIŞ ÜNİTE

Yalnızca yetkili servis personeli için.

Türkçe

[Original instructions]



PART No. 9379069755-02

## Contents

1. SAFETY PRECAUTIONS.....	2
2. ABOUT THIS PRODUCT	
2.1. Precautions for using R410A refrigerant.....	2
2.2. Special tools for R410A.....	3
2.3. Accessories.....	3
3. INSTALLATION WORK	
3.1. Selecting an installation location.....	3
3.2. Drain installation.....	4
3.3. Installation dimensions.....	4
3.4. Transporting the unit.....	5
3.5. Installation.....	5
4. PIPE SELECTION	
4.1. Selecting the pipe material.....	5
4.2. Protection of pipes.....	6
4.3. Refrigerant pipe size and allowable piping length.....	6
4.4. Connectable pipe diameter and max. piping length.....	6
5. PIPE INSTALLATION-1	
5.1. Opening a knock out hole.....	7
5.2. Brazing.....	7
5.3. Indoor unit pipe connections.....	7
5.4. Flare connection (pipe connection).....	7
5.5. Sealing test.....	8
5.6. Vacuum process.....	8
5.7. Additional charging.....	9
6. ELECTRICAL WIRING	
6.1. Notes for electrical wiring.....	10
6.2. Selecting circuit breaker and wiring.....	11
6.3. Knock out holes for wiring.....	11
6.4. Wiring method.....	11
7. PIPE INSTALLATION-2	
7.1. Installing insulation.....	12
7.2. Filling with putty.....	12
8. HOW TO OPERATE DISPLAY UNIT	
8.1. Display unit position.....	12
8.2. Description of display and button.....	13
9. FIELD SETTING	
9.1. Field setting buttons.....	13
9.2. Function settings.....	13
10. EXTERNAL INPUT AND OUTPUT	
10.1. External input.....	14
10.2. External output.....	15
11. TEST RUN	
11.1. Pre-test run check items.....	15
11.2. Test operation method.....	16
11.3. Checklist.....	16
12. ERROR CODES	
12.1. Error display mode.....	17
12.2. Error code check table.....	17
13. PUMP DOWN	
13.1. Preparation for pump down.....	18
13.2. Pump down procedure.....	18

## 1. SAFETY PRECAUTIONS

- Be sure to read this manual carefully before installation.
- The warnings and precautions indicated in this manual contain important information pertaining to your safety. Be sure to observe them.
- Hand this manual, together with the operating manual, to the customer. Request the customer to keep them on hand for future use, such as for relocating or repairing the unit.

### WARNING

This mark indicates procedures which, if improperly performed, might lead to the death or serious injury of the user.

### CAUTION

This mark indicates procedures which, if improperly performed, might possibly result in personal harm to the user, or damage to property.

### WARNING

Installation of this product must be done by experienced service technicians or professional installers only in accordance with this manual. Installation by nonprofessional or improper installation of the product may cause serious accidents such as injury, water leakage, electric shock, or fire. If the product is installed in disregard of the instructions in this manual, it will void the manufacturer's warranty

To avoid getting an electric shock, never touch the electrical components soon after the power supply has been turned off. After turning off the power, always wait 10 minutes or more before you touch the electrical components.

Do not turn ON the power until all work has been completed. Turning ON the power before the work is completed can cause serious accidents such as electric shock or fire.

If refrigerant leaks while work is being carried out, ventilate the area. If the refrigerant comes in contact with a flame, it produces a toxic gas.

Installation must be performed in accordance with regulations, codes, or standards for electrical wiring and equipment in each country, region, or the installation place.

### WARNING

Do not use this equipment with air or any other unspecified refrigerant in the refrigerant lines.

Excess pressure can cause a rupture.

During installation, make sure that the refrigerant pipe is attached firmly before you run the compressor.

Do not operate the compressor under the condition of refrigerant piping not attached properly with 2-way or 3-way valve open. This may cause abnormal pressure in the refrigeration cycle that leads to rupture and even injury.

When installing and relocating the air conditioner, do not mix gases other than the specified refrigerant (R410A) to enter the refrigerant cycle.

If air or other gas enters the refrigerant cycle, the pressure inside the cycle will rise to an abnormally high value and cause rupture, injury, etc.

To connect the indoor unit and outdoor unit, use air conditioner piping and cables available locally as standard parts. This manual describes proper connections using such installation set.

If the supply cord is damaged, it must be replaced by the manufacturer, its service agent or similarly qualified persons in order to avoid a hazard.

Do not modify power cable, use extension cable or branch wiring. Improper use may cause electric shock or fire by poor connection, insufficient insulation or over current.

Do not purge the air with refrigerants but use a vacuum pump to vacuum the installation.

There is not extra refrigerant in the outdoor unit for air purging.

Use a vacuum pump for R410A exclusively.

Using the same vacuum pump for different refrigerants may damage the vacuum pump or the unit.

Use a clean gauge manifold, vacuum pump and charging hose for R410A exclusively.

During the pump-down operation, make sure that the compressor is turned off before you remove the refrigerant piping.

Do not remove the connection pipe while the compressor is in operation with 2 way or 3 way valve open. This may cause abnormal pressure in the refrigeration cycle that leads to rupture and even injury.

This appliance is not intended for use by persons (including children) with reduced physical, sensory or mental capabilities, or lack of experience and knowledge, unless they have been given supervision or instruction concerning use of the appliance by a person responsible for their safety. Children should be supervised to ensure that they do not play with the appliance.

To avoid danger of suffocation, keep the plastic bag or thin film used as the packaging material away from young children.

### CAUTION

Read carefully all safety information written in this manual before you install or use the air conditioner.

Do not attempt to install the air conditioner or a part of the air conditioner by yourself.

This unit must be installed by qualified personnel with a capacity certificate for handling refrigerant fluids. Refer to regulation and laws in use on installation place.

Install the product by following local codes and regulations in force at the place of installation, and the instructions provided by the manufacturer.

This product is part of a set constituting an air conditioner. The product must not be installed alone or be installed with non-authorized device by the manufacturer.

Always use a separate power supply line protected by a circuit breaker operating on all wires with a distance between contact of 3 mm for this product.

To protect the persons, earth (ground) the product correctly, and use the power cable combined with an Earth Leakage Circuit Breaker (ELCB).

This product is not explosion proof, and therefore should not be installed in explosive atmosphere.

Do not touch the fins of the heat exchanger. Touching the heat exchanger fins could result in damage to the fins or personal injury such as skin rupture.

This product contains no user-serviceable parts. Always consult experienced service technicians for repairing.

When moving or relocating the air conditioner, consult experienced service technicians for disconnection and reinstallation of the product.

Children should be monitored to ensure they do not play with the device.

Do not place any other electrical products or household belongings under indoor unit or outdoor unit. Dripping condensation from the unit might get them wet, and may cause damage or malfunction of your property.

## 2. ABOUT THIS PRODUCT

### 2.1. Precautions for using R410A refrigerant

### WARNING

Do not introduce any substance other than the prescribed refrigerant into the refrigeration cycle. If air enters the refrigeration cycle, the pressure in the refrigeration cycle will become abnormally high and cause the piping to rupture.

If there is a refrigerant leak, make sure that it does not exceed the concentration limit. If a refrigerant leak exceeds the concentration limit, it can lead to accidents such as oxygen starvation.

⚠ <b>WARNING</b>
Do not touch refrigerant that has leaked from the refrigerant pipe connections or other areas. Touching the refrigerant directly can cause frostbite.
If a refrigerant leak occurs during operation, immediately vacate the premises and thoroughly ventilate the area. If the refrigerant comes in contact with a flame, it produces a toxic gas.
The basic installation work procedures are the same as conventional refrigerant (R22) models. However, pay careful attention to the following points:
Since the working pressure is 1.6 times higher than that of conventional refrigerant (R22) models, some of the piping and installation and service tools are special. (See the table below.) Especially, when replacing a conventional refrigerant (R22) model with a new refrigerant R410A model, always replace the conventional piping and flare nuts with the R410A piping and flare nuts.
Models that use refrigerant R410A have a different charging port thread diameter to prevent erroneous charging with conventional refrigerant (R22) and for safety. Therefore, check beforehand. [The charging port thread diameter for R410A is 1/2-20 UNF.]
Be more careful that foreign matter (oil, water, etc.) does not enter the piping than with refrigerant (R22) models. Also, when storing the piping, securely seal the opening by pinching, taping, etc.
When charging the refrigerant, take into account the slight change in the composition of the gas and liquid phases. And always charge from the liquid phase where refrigerant composition is stable.

## 2.2. Special tools for R410A

⚠ <b>WARNING</b>
To install a unit that uses R410A refrigerant, use dedicated tools and piping materials that have been manufactured specifically for R410A use. Because the pressure of R410A refrigerant is approximately 1.6 times higher than R22, failure to use dedicated piping material or improper installation can cause rupture or injury. Furthermore, it can cause serious accidents such as water leakage, electric shock, or fire.

Tool name	Contents of change
<b>Gauge manifold</b>	Pressure is high and cannot be measured with a conventional (R22) gauge. To prevent erroneous mixing of other refrigerants, the diameter of each port has been changed. It is recommended the gauge with seals -0.1 to 5.3 MPa (-1 to 53 bar) for high pressure. -0.1 to 3.8 MPa (-1 to 38 bar) for low pressure.
<b>Charge hose</b>	To increase pressure resistance, the hose material and base size were changed.
<b>Vacuum pump</b>	A conventional vacuum pump can be used by installing a vacuum pump adapter.
<b>Gas leakage detector</b>	Special gas leakage detector for HFC refrigerant R410A.

### Copper pipes

It is necessary to use seamless copper pipes and it is desirable that the amount of residual oil is less than 40 mg/10 m. Do not use copper pipes having a collapsed, deformed or discolored portion (especially on the interior surface). Otherwise, the expansion value or capillary tube may become blocked with contaminants.

As an air conditioner using R410A incurs pressure higher than when using R22, it is necessary to choose adequate materials.

Thicknesses of copper pipes used with R410A are as shown in the table. Never use copper pipes thinner than 0.8 mm even when it is available on the market.

### Thicknesses of Annealed Copper Pipes (R410A)





Pipe outside diameter [mm (in.)]	Thickness [mm]
6.35 (1/4)	0.80
9.52 (3/8)	0.80
12.70 (1/2)	0.80
15.88 (5/8)	1.00
19.05 (3/4)	1.20

## 2.3. Accessories

⚠ <b>WARNING</b>
For installation purposes, be sure to use the parts supplied by the manufacturer or other prescribed parts. The use of non-prescribed parts can cause serious accidents such as the unit falling, water leakage, electric shock, or fire.

Following installation parts are supplied. Use them as required.

Keep this manual in a safe place, and do not discard any other accessories until the installation work has been completed.

Name and shape	Q'ty	Description
Installation manual 	1	This manual
Drain pipe 	1	For outdoor unit drain piping work (May not be supplied, depending on the model.)
Drain cap 	2	
One-touch bush 	2	For power supply cable and connection cable installation

## 3. INSTALLATION WORK

Make sure to obtain the customer's approval for selecting and installing the outdoor unit.

### 3.1. Selecting an installation location

⚠ <b>WARNING</b>
Securely install the outdoor unit at a location that can withstand the weight of the unit. Otherwise, the outdoor unit may fall and cause injury.
Be sure to install the outdoor unit as prescribed, so that it can withstand earthquakes and typhoons or other strong winds. Improper installation can cause the unit to topple or fall, or other accidents.
Do not install the outdoor unit near the edge of a balcony. Otherwise, children may climb onto the outdoor unit and fall off of the balcony.

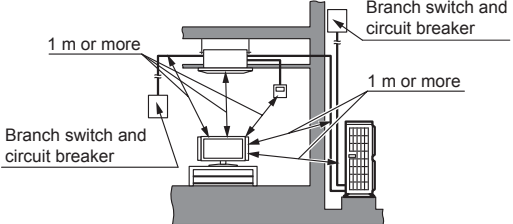
⚠ <b>CAUTION</b>
Do not install the outdoor unit in the following areas: <ul style="list-style-type: none"> <li>• Area with high salt content, such as at the seaside. It will deteriorate metal parts, causing the parts to fail or the unit to leak water.</li> <li>• Area filled with mineral oil or containing a large amount of splashed oil or steam, such as a kitchen. It will deteriorate plastic parts, causing the parts to fail or the unit to leak water.</li> <li>• Area that generates substances that adversely affect the equipment, such as sulfuric gas, chlorine gas, acid, or alkali. It will cause the copper pipes and brazed joints to corrode, which can cause refrigerant leakage.</li> <li>• Area containing equipment that generates electromagnetic interference. It will cause the control system to malfunction, preventing the unit from operating normally.</li> <li>• Area that can cause combustible gas to leak, contains suspended carbon fibers or flammable dust, or volatile inflammables such as paint thinner or gasoline. If gas leaks and settles around the unit, it can cause a fire.</li> <li>• Area where small animals may live. It may cause failure, smoke or fire if small animals enter and touch internal electrical parts.</li> <li>• Area where animals may urinate on the unit or ammonia may be generated.</li> </ul>
Do not tilt the outdoor unit more than 3 degrees.
Install the outdoor unit in a well-ventilated location away from rain or direct sunlight.
If the outdoor unit must be installed in an area within easy reach of the general public, install as necessary a protective fence or the like to prevent their access.
Install the outdoor unit in a location that would not inconvenience your neighbors, as they could be affected by the airflow coming out from the outlet, noise, or vibration. If it must be installed in proximity to your neighbors, be sure to obtain their approval.
If the outdoor unit is installed in a cold region that is affected by snow accumulation, snow fall, or freezing, take appropriate measures to protect it from those elements. To ensure a stable operation, install inlet and outlet ducts.
Install the outdoor unit in a location that is away from exhaust or the vent ports that discharge vapor, soot, dust, or debris.
Install the indoor unit, outdoor unit, power supply cable, transmission cable, and remote control cable at least 1 m away from a television or radio receivers. The purpose of this is to prevent TV reception interference or radio noise. (Even if they are installed more than 1 m apart, you could still receive noise under some signal conditions.)

**CAUTION**

If children under 10 years old may approach the unit, take preventive measures so that they cannot reach the unit.

Keep the length of the piping of the indoor and outdoor units within the allowable range.

For maintenance purposes, do not bury the piping.

**3.2. Drain installation**

**CAUTION**

Perform drain work in accordance with this Manual, and ensure that the drain water is properly drained. If the drain work is not carried out correctly, water may drip down from the unit, wetting the furniture.

When the outdoor temperature is 0 °C or less, do not use the accessory drain pipe and drain cap. If the drain pipe and drain cap are used, the drain water in the pipe may freeze in extremely cold weather. (Reverse cycle model only)

- As the drain water flows out of the outdoor unit during heating operation, install the drain pipe and connect it to a commercial 16 mm hose. (Reverse cycle model only)
- When installing the drain pipe, plug all the holes other than the drain pipe mounting hole in the bottom of the outdoor unit with putty so there is no water leakage. (Reverse cycle model only)

(Unit : mm)

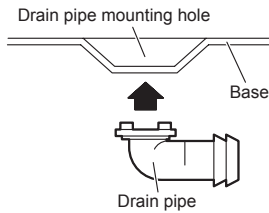
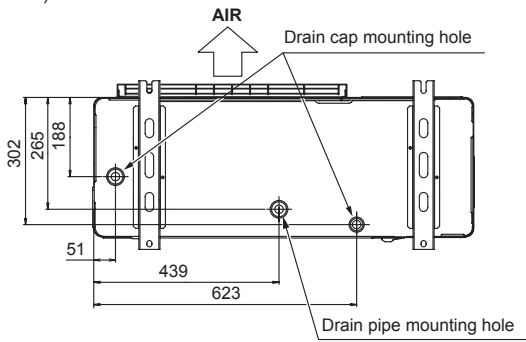

**3.3. Installation dimensions**

**CAUTION**

The installation space shown in the following examples is based on an ambient temperature under cooling operation of 35 °C (DB) at the air intake of the outdoor unit. Provide more space around the air intake than shown in the examples if the ambient temperature exceeds 35 °C (DB) or if the thermal load of all of the outdoor units exceeds the capacity.

Consider the transportation route, installation space, maintenance space, and access, and install the unit in a location with sufficient space for the refrigerant piping.

Observe the installation space specifications that are shown in the figures. Keep the same space at rear air intake.

Provide the same space for the air intake at the rear of the outdoor unit. If the installation is not performed according to the specifications, it could cause a short circuit and result in a lack of operating performance. As a result, the outdoor unit might easily be stopped by high-pressure protection.

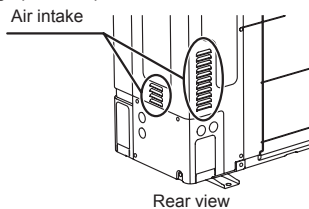

Installation methods not shown in the following examples are not recommended. Performance may drop significantly.

**3.3.1. Single outdoor unit installation**

**When the upward area is open** (Unit : mm)

(1) Obstacles at rear only

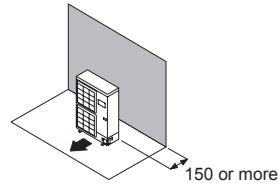

(2) Obstacles at rear and sides only

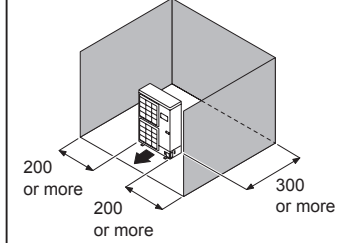

(3) Obstacles at front only

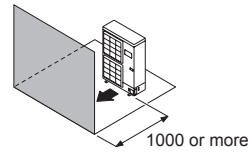

(4) Obstacles at front and rear only

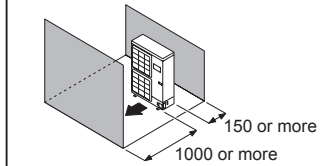

**When an obstruction is present also in the upward area** (Unit : mm)

(1) Obstacles at rear and above only

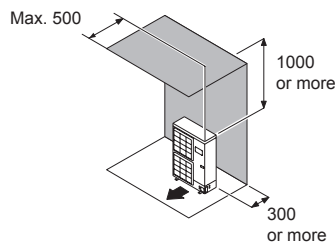

(2) Obstacles at rear, sides, and above only

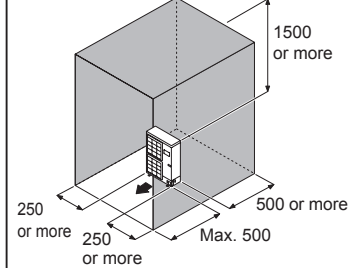

**3.3.2. Multiple outdoor unit installation**

- Provide at least 15 mm of space between the outdoor units if multiple units are installed.
- When routing the piping from the side of an outdoor unit, provide space for the piping.
- No more than 3 units must be installed side by side. When 3 units or more are arranged in a line, provide the space as shown in the following example when an obstruction is present also in the upward area.

**When the upward area is open** (Unit : mm)

(1) Obstacles at rear only

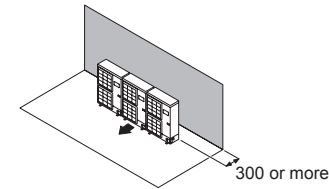

(2) Obstacles at front only

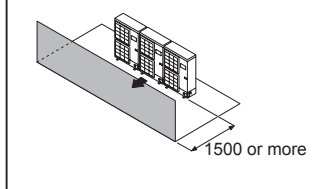

(3) Obstacles at front and rear only

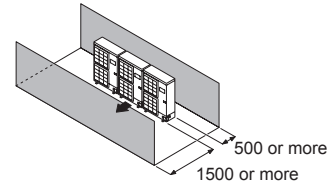

**When an obstruction is present also in the upward area** (Unit : mm)

Obstacles at rear and above only

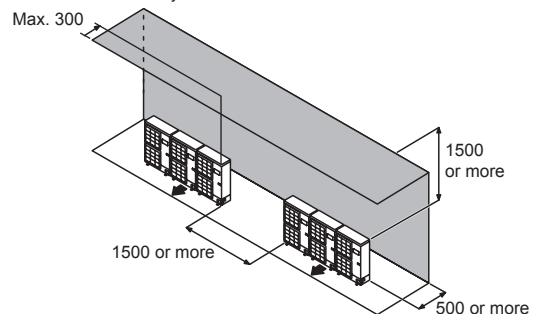

### 3.3.3. Outdoor units installation in multi row (Unit : mm)

(1) Single parallel unit arrangement

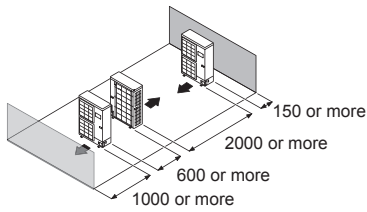

(2) Multiple parallel unit arrangement

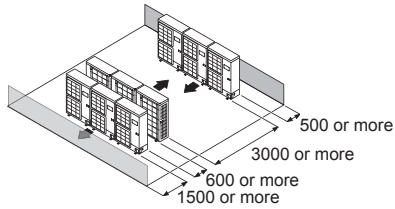

### 3.4. Transporting the unit

#### ⚠ WARNING

Do not touch the fins.  
Otherwise, personal injury could result.

#### ⚠ CAUTION

When carrying the unit, hold the handles on the right and left sides and be careful. If the outdoor unit is carried from the bottom, hands or fingers may be pinched.

- Carry slowly in the manner as shown on "Fig. B" holding the handles "Fig. A" in right and left sides. (Be careful not to touch with hands or objects.)
- Be sure to hold the handles on the sides of the unit. Otherwise, the suction grilles on the sides of the unit may be deformed.

Fig. A

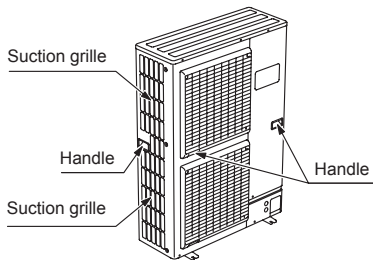
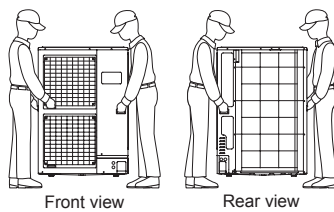
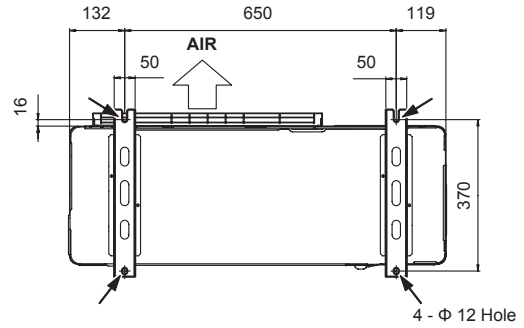

Fig. B



### 3.5. Installation

(Unit : mm)



- Install 4 anchor bolts at the locations indicated with arrows in the above figure.
- To reduce vibration, do not install the unit directly on the ground. Install it on a secure base (such as concrete blocks).
- The foundation shall support the legs of the unit and have a width of 50 mm or more.
- Depending on the installation conditions, the outdoor unit may spread its vibration during operation, which may cause noise and vibration. Therefore, attach damping materials (such as damping pads) to the outdoor unit during installation.
- Install the foundation, making sure that there is enough space for installing the connection pipes.
- Secure the unit to a solid block using foundation bolts. (Use 4 sets of commercially available M10 bolts, nuts, and washers.)
- The bolts should protrude 20 mm. (Refer to the figure below.)
- If overturning prevention is required, purchase the necessary commercially available items.

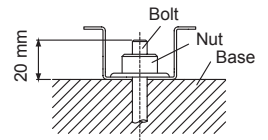

Fix securely with bolts on a solid block. (Use 4 sets of commercially available M10 bolt, nut and washer.)

### 4. PIPE SELECTION

#### 4.1. Selecting the pipe material

#### ⚠ CAUTION

Do not use existing pipes.

Use pipes that have clean external and internal sides without any contamination which may cause trouble during use, such as sulfur, oxide, dust, cutting waste, oil, or water.

It is necessary to use seamless copper pipes.

Material: Phosphor deoxidized seamless copper pipes.

It is desirable that the amount of residual oil is less than 40 mg/10 m.

Do not use copper pipes that have a collapsed, deformed, or discolored portion (especially on the interior surface). Otherwise, the expansion valve or capillary tube may become blocked with contaminants.

Improper pipe selection will degrade performance. As an air conditioner using R410A incurs pressure higher than when using conventional refrigerant, it is necessary to choose adequate materials.

#### Note:

Thicknesses of copper pipes used with R410A are as shown in the table.

Never use copper pipes thinner than those indicated in the table even if they are available on the market.

#### Thicknesses of Annealed Copper Pipes (R410A)

Pipe outside diameter [mm (in.)]	Thickness [mm]
6.35 (1/4)	0.8
9.52 (3/8)	
12.70 (1/2)	
15.88 (5/8)	1.0
19.05 (3/4)	1.2



## 4.2. Protection of pipes

Protect the pipes to prevent the entry of moisture and dust. Especially, pay attention when passing the pipes through a hole or connecting the end of a pipe to the outdoor unit.

Location	Working period	Protection method
Outdoor	1 month or more	Pinch pipes
	Less than 1 month	Pinch or tape pipes
Indoor	-	Pinch or tape pipes

## 4.3. Refrigerant pipe size and allowable piping length

### ⚠ CAUTION

Keep the piping length between the indoor unit and outdoor unit within the allowable tolerance.

### 4.3.1. Simultaneous operation multi type installation

### ⚠ CAUTION

Be certain to install indoor units in the same room because the combinations are for simultaneous operation.

The lengths after branching should be equal if possible.

### Twin type

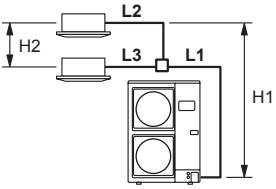
Capacity [Btu/h class]	36,000	45,000	54,000
Indoor unit capacity [Btu/h class]	18,000 + 18,000	22,000 + 22,000	24,000 + 24,000
Main pipe diameter (L1) <Liquid/Gas> (Standard) [mm (in.)]	9.52 (3/8) / 15.88 (5/8)		
Branch pipe diameter (L2, L3) <Liquid/Gas> [mm (in.)]	6.35 (1/4) / 12.70 (1/2)	9.52 (3/8) / 15.88 (5/8)	
Max. piping length (L1+L2+L3) [m]	75 <sup>*1</sup>		
Min. piping length (L1+L2+L3) [m]	5		
Max. branch piping length (L2, L3) [m]	20		
Max. difference between branch lengths (L2 to L3) [m]	8		
Max. height difference (H1) <Indoor unit to outdoor unit> [m]	30		
Max. height difference (H2) <Indoor unit to indoor unit> [m]	0.5		
View (Example)			

\*1: For the standard pipe diameter.

### Triple type

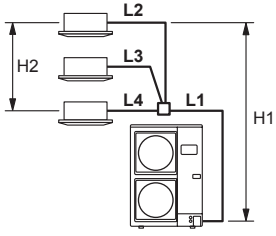
Capacity [Btu/h class]	54,000
Indoor unit capacity [Btu/h class]	18,000 + 18,000 + 18,000
Main pipe diameter (L1) <Liquid/Gas> (Standard) [mm (in.)]	9.52 (3/8) / 15.88 (5/8)
Branch pipe diameter (L2, L3, L4) <Liquid/Gas> [mm (in.)]	6.35 (1/4) / 12.70 (1/2)
Max. piping length (L1+L2+L3+L4) [m]	75 <sup>*1</sup>
Min. piping length (L1+L2+L3+L4) [m]	5
Max. branch piping length (L2, L3, L4) [m]	20
Max. difference between branch lengths (L2 to L4) [m]	8
Max. height difference (H1) <Indoor unit to outdoor unit> [m]	30
Max. height difference (H2) <Indoor unit to indoor unit> [m]	0.5
View (Example)	

\*1: For the standard pipe diameter.

## 4.4. Connectable pipe diameter and max. piping length

### 4.4.1. Simultaneous operation multi type installation

#### Twin type

Capacity [Btu/h class]	36,000	
Main piping [mm (in.)]	Liquid pipes	9.52 (3/8)
	Gas pipes	15.88 (5/8)
Branch piping [mm (in.)]	Liquid pipes	6.35 (1/4)
	Gas pipes	12.70 (1/2)
Piping length [m (m)]	Max. piping length <L1+L2+L3> <sup>*1</sup> (Pre-charge length)	75 [30]
	Capacity [Btu/h class]	45,000 / 54,000
Main piping [mm (in.)]	Liquid pipes	9.52 (3/8)
	Gas pipes	15.88 (5/8)
Branch piping [mm (in.)]	Liquid pipes	9.52 (3/8)
	Gas pipes	15.88 (5/8)
Piping length [m (m)]	Max. piping length <L1+L2+L3> <sup>*1</sup> (Pre-charge length)	75 [30]

\*1: Refer to "View" in Twin type of 4.3.1. Simultaneous operation multi type installation.

#### Triple type

Capacity [Btu/h class]	54,000	
Main piping [mm (in.)]	Liquid pipes	9.52 (3/8)
	Gas pipes	15.88 (5/8)
Branch piping [mm (in.)]	Liquid pipes	6.35 (1/4)
	Gas pipes	12.70 (1/2)
Piping length [m (m)]	Max. piping length <L1+L2+L3+L4> <sup>*1</sup> (Pre-charge length)	75 [30]

\*1: Refer to "View" in Triple type of 4.3.1. Simultaneous operation multi type installation.

## 5. PIPE INSTALLATION-1

### 5.1. Opening a knock out hole

#### ⚠ CAUTION

Be careful not to deform or scratch the panel while opening the knock out holes.

To protect the piping insulation after opening a knock out hole, remove any burrs from the edge of the hole. It is recommended to apply rust prevention paint to the edge of the hole.

- Pipes can be connected from 4 directions, front, lateral side, rear side and bottom. (Fig. A)
- When connecting at the bottom, remove the service panel and piping cover on the front of the outdoor unit, and open the knock out hole provided at the bottom corner of the piping outlet.
- It can be installed as shown on "Fig. B" cutting out the 2 slits as indicated on "Fig. C". (When cutting slits, use a steel saw.)

Fig. A

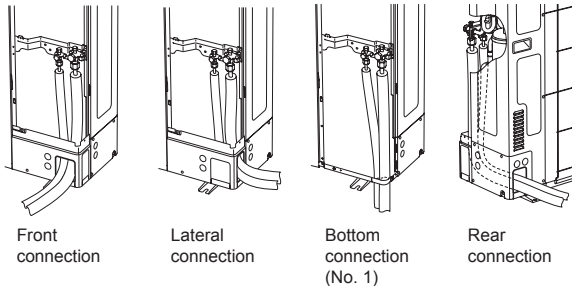
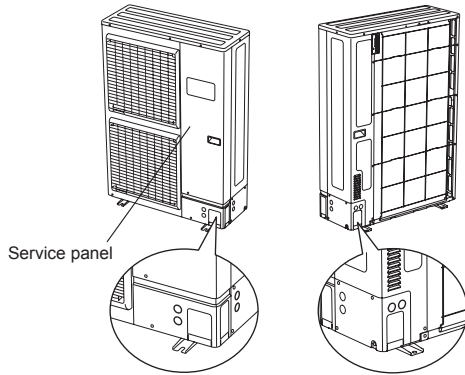

Fig. B

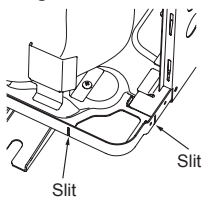
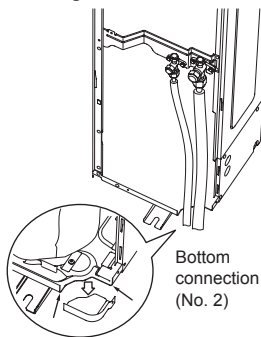

Fig. C



### 5.2. Brazing

#### ⚠ CAUTION

If air or another type of refrigerant enters the refrigeration cycle, the internal pressure in the refrigeration cycle will become abnormally high and prevent the unit from exerting its full performance.

Apply nitrogen gas while brazing the pipes. If a pipe is brazed without applying nitrogen gas, an oxidation film will be created. This can degrade performance or damage the parts in the unit (such as the compressor or valves).

Nitrogen gas pressure: 0.02 MPa  
(= pressure felt sufficiently on the back of the hand)

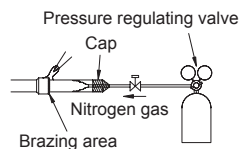

#### ⚠ CAUTION

For brazing material, use phosphor copper that does not require flux. Do not use flux to braze pipes. If the flux is the chlorine type, it will cause the pipes to corrode. Furthermore, if the flux contains fluoride, it will adversely affect the refrigerant pipe system such as by degrading the refrigerant. If fluoride is contained, quality of refrigerant deteriorates and affects the refrigerant piping system.

### 5.3. Indoor unit pipe connections

#### 5.3.1. Precautions for connecting simultaneous operation multi

#### ⚠ CAUTION

Use genuine branch pipes for the refrigerant piping branches. Branch pipes are twin or triple type for concurrent operation, and may be used for piping between the outdoor and indoor units.

Select a twin or triple type branch pipe and purchase it before starting the installation work.

Shorten the length of branch pipes from a branch to indoor unit as short as possible. Maximum length: within 20 m.

Branch pipes shall be connected by welding (brazing).

Any vertical piping shall be in the part of the main piping. If a main pipe is bent, keep the straight part more than 10 times the diameter of the connected pipe. A variance in the amount of refrigerant may be caused if the straight part is short.

For details, refer to the Installation Manual of branch pipes.

#### 5.3.2. Type of branch pipes

##### In case of a simultaneous operation multi (twin connection)

The liquid pipes and gas pipes shall be selected from the table below according to the diameter, and welded.

Small pipe diameter	
Liquid pipe	Gas pipe
Large pipe diameter	
Liquid pipe	Gas pipe

##### In case of a simultaneous operation multi (triple connection)

Weld the branch pipe shown at the left for liquid pipes, and the branch pipe shown at the right for gas pipes.

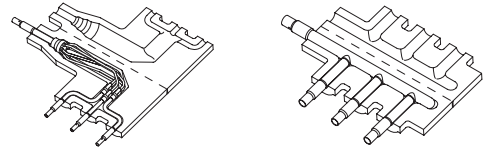

### 5.4. Flare connection (pipe connection)

#### ⚠ CAUTION

Do not use mineral oil on a flared part. Prevent mineral oil from getting into the system as this would reduce the lifetime of the units.

While welding the pipes, be sure to blow dry nitrogen gas through them.

The maximum lengths of this product are shown in the table. If the units are further apart than this, correct operation cannot be guaranteed.

#### 5.4.1. Flaring

Use special pipe cutter and flare tool exclusive for R410A.

- (1) Cut the connection pipe to the necessary length with a pipe cutter.
- (2) Hold the pipe downward so that the cuttings will not enter the pipe and remove any burrs.
- (3) Insert the flare nut (always use the flare nut attached to the indoor and outdoor units respectively) onto the pipe and perform the flare processing with a flare tool. Leakage of refrigerant may result if other flare nuts are used.
- (4) Protect the pipes by pinching them or with tape to prevent dust, dirt, or water from entering the pipes.

Check if [L] is flared uniformly and is not cracked or scratched.

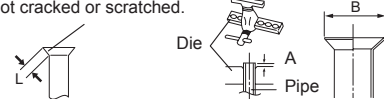

Pipe outside diameter [mm (in.)]	Dimension A [mm]
	Flare tool for R410A, clutch type
6.35 (1/4)	0 to 0.5
9.52 (3/8)	
12.70 (1/2)	
15.88 (5/8)	
19.05 (3/4)	

Pipe outside diameter [mm (in.)]	Dimension B <sub>0</sub> -0.4 [mm]
	6.35 (1/4)
9.52 (3/8)	13.2
12.70 (1/2)	16.6
15.88 (5/8)	19.7
19.05 (3/4)	24.0

When using conventional flare tools to flare R410A pipes, the dimension A should be approximately 0.5 mm more than indicated in the table (for flaring with R410A flare tools) to achieve the specified flaring. Use a thickness gauge to measure the dimension A.

Width across flats



Pipe outside diameter [mm (in.)]	Width across flats of Flare nut [mm]
6.35 (1/4)	17
9.52 (3/8)	22
12.70 (1/2)	26
15.88 (5/8)	29
19.05 (3/4)	36

### 5.4.2. Bending pipes

#### CAUTION

To prevent breaking of the pipe, avoid sharp bends. Bend the pipe with a radius of curvature of 100 mm to 150 mm.

If the pipe is bent repeatedly at the same place, it will break.

- If pipes are shaped by hand, be careful not to collapse them.
- Do not bend the pipes at an angle of more than 90°.
- When pipes are repeatedly bent or stretched, the material will harden, making it difficult to bend or stretch them any more.
- Do not bend or stretch the pipes more than three times.

### 5.4.3. Pipe connection

#### CAUTION

Be sure to install the pipe against the port on the indoor unit and the outdoor unit correctly. If the centering is improper, the flare nut cannot be tightened smoothly. If the flare nut is forced to turn, the threads will be damaged.

Do not remove the flare nut from the outdoor unit pipe until immediately before connecting the connection pipe.

After installing the piping, make sure that the connection pipes do not touch the compressor or outer panel. If the pipes touch the compressor or outer panel, they will vibrate and produce noise.

- (1) Detach the caps and plugs from the pipes.
- (2) Center the pipe against the port on the outdoor unit, and then turn the flare nut by hand.
- (3) Tighten the flare nut of the connection pipe at the outdoor unit valve connector.

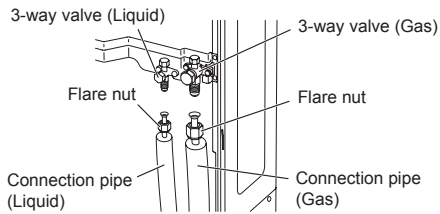

- (4) After tightening the flare nut by hand, use a torque wrench to fully tighten it.

#### CAUTION

Hold the torque wrench at its grip, keeping it in a right angle with the pipe, in order to tighten the flare nut correctly.

- Outer panel may be distorted if fastened only with a wrench. Be sure to fix the elementary part with a spanner and fasten with a wrench (refer to below diagram).
- Do not apply force to the blank cap of the valve or hang a wrench, etc., on the cap. It may cause leakage of refrigerant.

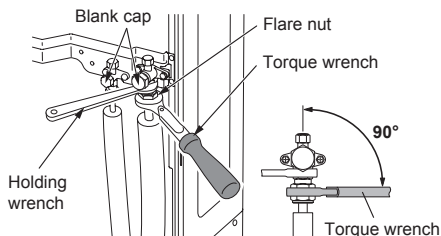

Flare nut [mm (in.)]	Tightening torque [N·m (kgf·cm)]
6.35 (1/4) dia.	16 to 18 (160 to 180)
9.52 (3/8) dia.	32 to 42 (320 to 420)
12.70 (1/2) dia.	49 to 61 (490 to 610)
15.88 (5/8) dia.	63 to 75 (630 to 750)
19.05 (3/4) dia.	90 to 110 (900 to 1100)

### 5.4.4. Handling precautions for the valves

- Mounted part of Blank cap is sealed for protection.
- Fasten blank cap tightly after opening valves.

Table A

Blank cap [mm (in.)]	Tightening torque [N·m (kgf·cm)]
6.35 (1/4)	20 to 25 (200 to 250)
9.52 (3/8)	20 to 25 (200 to 250)
12.70 (1/2)	25 to 30 (250 to 300)
15.88 (5/8)	30 to 35 (300 to 350)
19.05 (3/4)	35 to 40 (350 to 400)

### Operating the valves

- Use a hexagon wrench (size 4 mm).
- Opening
  - (1) Insert the hexagon wrench into the valve shaft, and turn it counterclockwise.
  - (2) Stop turning when the valve shaft can no longer be turned. (Open position)
- Closing
  - (1) Insert the hexagon wrench into the valve shaft, and turn it clockwise.
  - (2) Stop turning when the valve shaft can no longer be turned. (Closed position)

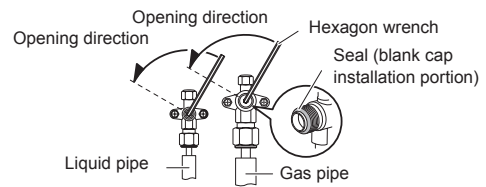

## 5.5. Sealing test

#### WARNING

Before operating the compressor, install the pipes and securely connect them. Otherwise, if the pipes are not installed and if the valves are open when the compressor operates, air could enter the refrigeration cycle. If this happens, the pressure in the refrigeration cycle will become abnormally high and cause damage or injury.

After the installation, make sure there is no refrigerant leakage. If the refrigerant leaks into the room and becomes exposed to a source of fire such as a fan heater, stove, or burner, it produces a toxic gas.

Do not subject the pipes to strong shocks during the sealing test. It can rupture the pipes and cause serious injury.

#### CAUTION

Do not block the walls and the ceiling until the sealing test and the charging of the refrigerant gas have been completed.

For maintenance purposes, do not bury the piping of the outdoor unit.

- After connecting the pipes, perform a sealing test.
- Make sure that the 3-way valves are closed before performing a sealing test.
- Pressurize nitrogen gas to 4.15 MPa to perform the sealing test.
- Add nitrogen gas to both the liquid pipes and the gas pipes.
- Check all flare connections and welds. Then, check that the pressure has not decreased.
- Compare the pressures after pressurizing and letting it stand for 24 hours, and check that the pressure has not decreased.
  - \* When the outdoor air temperature changes 5 °C, the test pressure changes 0.05 MPa. If the pressure has dropped, the pipe joints may be leaking.
- If a leak is found, immediately repair it and perform the sealing test again.
- After completing the sealing test, release the nitrogen gas from both valves.
- Release the nitrogen gas slowly.

## 5.6. Vacuum process

#### CAUTION

Perform a refrigerant leakage test (air tightness test) to check for leaks using nitrogen gas while all valves in the outdoor unit are closed. (Use the test pressure indicated on the nameplate.)

Be sure to evacuate the refrigerant system using a vacuum pump.

The refrigerant pressure may sometimes not rise when a closed valve is opened after the system is evacuated using a vacuum pump. This is caused by the closure of the refrigerant system of the outdoor unit by the electronic expansion valve. This will not affect the operation of the unit.

If the system is not evacuated sufficiently, its performance will drop.



**CAUTION**

Use a clean gauge manifold and charging hose that were designed specifically for use with R410A. Using the same vacuum equipment for different refrigerants may damage the vacuum pump or the unit.

Do not purge the air with refrigerants, but use a vacuum pump to evacuate the system.

- (1) Check that the valves are closed by removing the blank caps from the gas and liquid pipes.
- (2) Remove the charging port cap, and connect the gauge manifold and the vacuum pump to the charging valve with the service hoses.
- (3) Vacuum the indoor unit and the connecting pipes until the pressure gauge indicates  $-0.1$  MPa ( $-76$  cmHg).
- (4) When  $-0.1$  MPa ( $-76$  cmHg) is reached, operate the vacuum pump for at least 60 minutes.
- (5) Disconnect the service hoses and fit the charging port cap to the charging valve to the specified torque. (Refer to below table)
- (6) Remove the blank caps, and fully open the 3-way valves with a hexagon wrench [Torque: 6 to 7 N·m (60 to 70 kgf·cm)].
- (7) Tighten the blank caps of the 3-way valve to the specified torque. (Refer to Table A on page 8.)

Tightening torque [N·m (kgf·cm)]	
Charging port cap	10 to 12 (100 to 120)

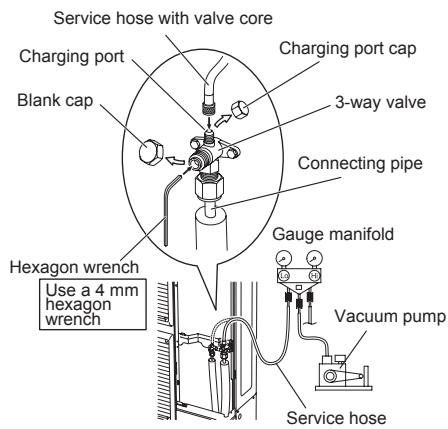

**Simultaneous operation multi type**

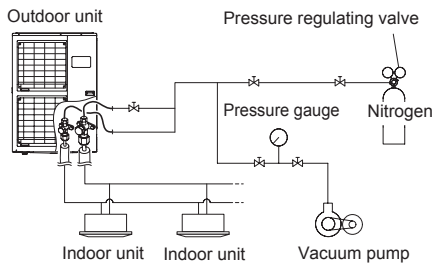

**5.7. Additional charging**

**WARNING**

When moving and installing the air conditioner, do not mix gas other than the specified refrigerant R410A inside the refrigerant cycle. If air or other gas enters the refrigerant cycle, the pressure inside the cycle will rise to an abnormally high value and cause breakage, injury, etc.

**CAUTION**

After vacuuming the system, add refrigerant.

Do not reuse recovered refrigerant.

When charging the refrigerant R410A, always use an electronic scales for refrigerant charging (to measure the refrigerant by weight). Adding more refrigerant than the specified amount will cause a malfunction.

When charging the refrigerant, take into account the slight change in the composition of the gas and liquid phases, and always charge from the liquid phase side whose composition is stable. Adding refrigerant through the gas pipe will cause a malfunction.

Check if the steel cylinder has a siphon installed or not before filling. (There is an indication "with siphon for filling liquid" on the steel cylinder.)

**Filling method for cylinder with siphon**

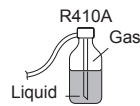

Set the cylinder vertical and fill with the liquid. (Liquid can be filled without turning bottom up with the siphon inside.)

**Filling method for other cylinders**

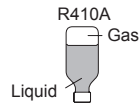

Turn bottom up and fill with liquid. (Be careful to avoid turning over the cylinder.)

Be sure to use the special tools for R410A for pressure resistance and to avoid mixing of impure substances.

If the units are further apart than the maximum pipe length, correct operation can not be guaranteed.

Make sure to back closing valve after refrigerant charging. Otherwise, the compressor may fail.

Minimize refrigerant release to the air. Excessive release is prohibited under the Freon Collection and Destruction Law.

**5.7.1. For Pre-charge length**

Piping length (L) *Pre-Charge [m]
30

**5.7.2. If additional refrigerant is required**

- When the piping is longer than Pre-charge length, additional charging is necessary.
- For the additional amount, see the table below.

**Additional charging amount**

**Simultaneous operation multi type**

Twin : $L_1+L_2+L_3$ (*1) > Pre-charge length
Triple : $L_1+L_2+L_3+L_4$ (*2) > Pre-charge length

\*1 : Refer to "View" in the table of "4.3.1. Simultaneous operation multi type installation."

\*2 : Refer to "View" in the table of "4.3.1. Simultaneous operation multi type installation."

The additional charging amount for twin / triple type will be calculated as follows:

Additional charging amount (g)
$= (A \times 50) + (B \times 30) - 1,500$
• A = Piping length (m) of liquid pipe [9.52 mm (3/8 in.)]
• B = Piping length (m) of liquid pipe [6.35 mm (1/4 in.)]

Do not remove refrigerant, even if the additional amount calculated is negative.

**(Example 1)**

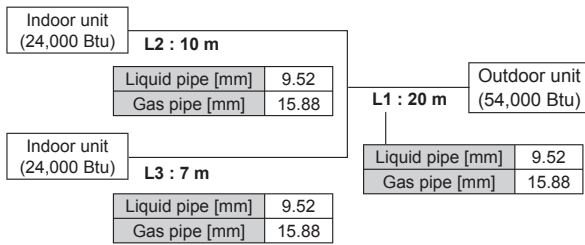

Additional charging amount

Liquid pipe diameter [mm]	Piping length [m]	Coefficient
9.52	37	A = 37
6.35	0	B = 0

Applying the formula,  
 $(37 \times 50) + (0 \times 30) - 1500 = 350$   
 The additional charging amount is 350 g.

**(Example 2)**

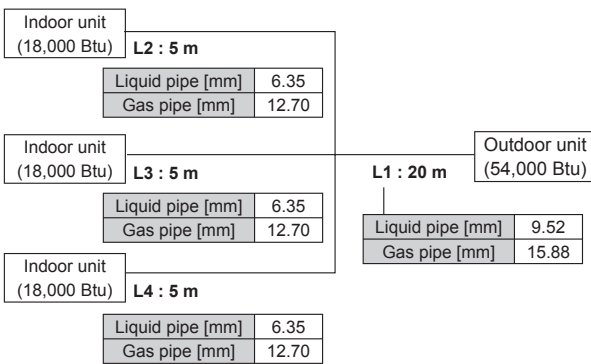

Additional charging amount

Liquid pipe diameter [mm]	Piping length [m]	Coefficient
9.52	20	A = 20
6.35	15	B = 15

Applying to the formula,  
 $(20 \times 50) + (15 \times 30) - 1500 = -50$   
 The calculated value is negative. Do not add or remove any refrigerant.

## 6. ELECTRICAL WIRING

### 6.1. Notes for electrical wiring

**⚠ WARNING**

Wiring connections must be performed by a qualified person in accordance with the specifications. The voltage rating for this product is 230 V at 50 Hz. It should be operated within the range of 198 to 264 V.

Before connecting the wires, make sure the power supply is OFF.

Use a dedicated power supply circuit. Insufficient power capacity in the electrical circuit or improper wiring may cause electric shock or fire.

Install a breaker at the power supply for each outdoor unit. Improper breaker selection can cause electric shock or fire.

Install a leakage circuit breaker in accordance with the related laws and regulations. An improperly installed electrical box cover can cause serious accidents such as electric shock or fire through exposure to dust or water.

A circuit breaker is installed in the permanent wiring. Always use a circuit that can trip all the poles of the wiring and has an isolation distance of at least 3 mm between the contacts of each pole.

Use designated cables and power cables. Improper use may cause electric shock or fire by poor connection, insufficient insulation, or over current.

Do not modify power cable, use extension cable or branch wiring. Improper use may cause electric shock or fire by poor connection, insufficient insulation or over current.

Connect the connector cable securely to the terminal. Check no mechanical force bears on the cables connected to the terminals. Faulty installation can cause a fire.

Use ring terminals and tighten the terminal screws to the specified torques, otherwise, abnormal overheating may be produced and possibly cause serious damage inside the unit.

**⚠ WARNING**

Make sure to secure the insulation portion of the connector cable with the cable clamp. Damaged insulation can cause a short circuit.

Fix cables so that cables do not make contact with the pipes (especially on high pressure side). Do not make power supply cable and transmission cable come in contact with valves (Gas).

Never install a power factor improvement condenser. Instead of improving the power factor, the condenser may overheat.

Be sure to perform the earthing (grounding) work. Do not connect earthing (grounding) wires to a gas pipe, water pipe, lightning rod or earthing (grounding) wire for a telephone.

- Connection to a gas pipe may cause a fire or explosion if gas leaks.
- Connection to a water pipe is not an effective earthing (grounding) method if PVC pipe is used.
- Connection to the earthing (grounding) wire of a telephone or to a lightning rod may cause a dangerously abnormal rise in the electrical potential if lightning strikes. Improper earthing (grounding) work can cause electric shocks.

Securely install the electrical box cover on the unit. An improperly installed service panel can cause serious accidents such as electric shock or fire through exposure to dust or water.

**⚠ CAUTION**

The primary power supply capacity is for the air conditioner itself, and does not include the concurrent use of other devices.

Do not start operation until the refrigerant is charged completely. The compressor will fail if it is operated before the refrigerant piping charging is complete.

Transmission cable between indoor unit and outdoor unit is 230 V.

Be sure not to remove thermistor sensor etc. from power wiring and connection wiring. Compressor may fail if operated while removed.

Start wiring work after closing branch switch and over current breaker.

Use an earth leakage breaker that is capable of handling high frequencies. Because the outdoor unit is inverter controlled, a high-frequency earth leakage breaker is necessary to prevent a malfunction of the breaker itself.

When using an earth leakage breaker that has been designed solely for earth (ground) fault protection, be sure to install a fuse-equipped switch or circuit breaker.

Do not connect the AC power supply to the transmission line terminal board. Improper wiring can damage the entire system.

Do not use crossover power supply wiring for the outdoor unit.

If the temperature surrounding the breaker is too high, the amperage at which the breaker cuts out may decrease.

**How to connect wiring to the terminal**

Caution when wiring cable

When stripping off the coating of a lead wire, always use a special tool such as a wire stripper. If there is no special tool available, carefully strip the coating with a knife etc.

- (1) Use ring terminals with insulating sleeves as shown in the figure below to connect to the terminal block.
- (2) Securely clamp the ring terminals to the wires using an appropriate tool so that the wires do not come loose.

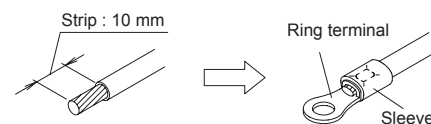

- (3) Use the specified wires, connect them securely, and fasten them so that there is no stress placed on the terminals.
- (4) Use an appropriate screwdriver to tighten the terminal screws. Do not use a screwdriver that is too small, otherwise, the screw heads may be damaged and prevent the screws from being properly tightened.
- (5) Do not tighten the terminal screws too much, otherwise, the screws may break.

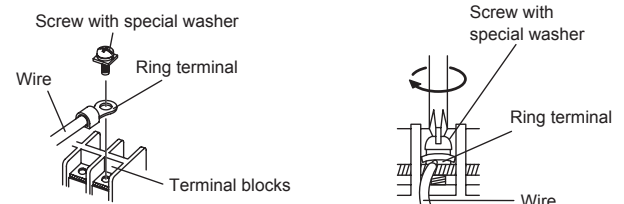

- (6) See the table below for the terminal screw tightening torques.

Tightening torque [N·m (kgf·cm)]	
M4 screw	1.2 to 1.8 (12 to 18)
M5 screw	2.0 to 3.0 (20 to 30)

## 6.2. Selecting circuit breaker and wiring

### ⚠ CAUTION

Be sure to install a breaker with specified capacity.

Before the electrical working, confirm electrical standards and regulations in each country, region, or installing place. Then select appropriate cables and breakers that comply with them.

Decide the diameter of wire referring to below table "Breaker and wiring specifications" in accordance with local and national codes.

#### Breaker and wiring specifications

Breaker capacity [A]	Power supply cable	Transmission cable	
	Conductor size [mm <sup>2</sup> ]	Conductor size [mm <sup>2</sup> ]	Max. length [m]
30	6.0	1.5	75

- Max. wire length: Set a length so that the voltage drop is less than 2%. Increase the wire diameter when the wire length is long.
- Use confirmed cable with type 60245 IEC 57.
- Install a circuit breaker with a contact gap of at least 3 mm in all poles nearby the units. (Both indoor units and outdoor units)

## 6.3. Knock out holes for wiring

### ⚠ CAUTION

Be careful not to deform or scratch the panel while opening the knock out holes.

When cables are routed from the unit, a protection sleeve for the conduits can be inserted at the knock out hole.

If you do not use a wire conduit, be sure to protect the wires to prevent the edge of the knock out hole from cutting the wires.

It is recommended to apply anti-rust paint to the edge of the knock out hole.

- Knock out holes are provided for wiring. (Fig. A)
- Knock out holes are provided 2 each in the same size in front, lateral and rear sides. (Fig. B)

Fig. A

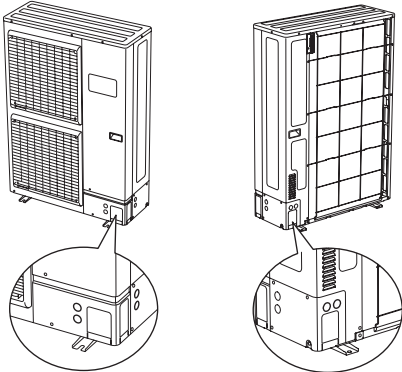
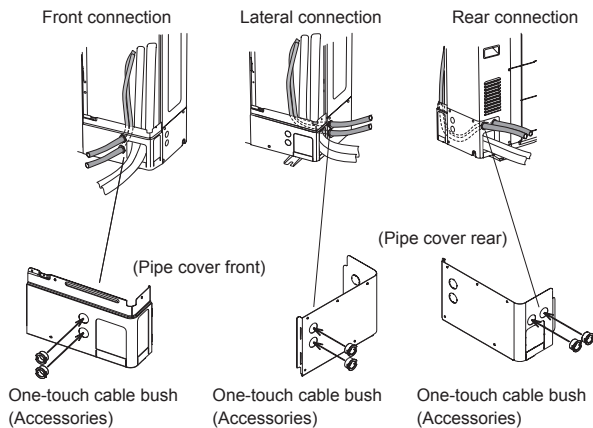

Fig. B

#### Installation method of One-touch bush

Please fix the One-touch bush (accessory) as shown in the figure below.



Note : Please ensure that the power cable and interconnecting cables are not installed through the same cable bush hole opening. They must be installed into the two separate hole openings to prevent damage to the cable.

## 6.4. Wiring method

### 6.4.1. Connection diagrams

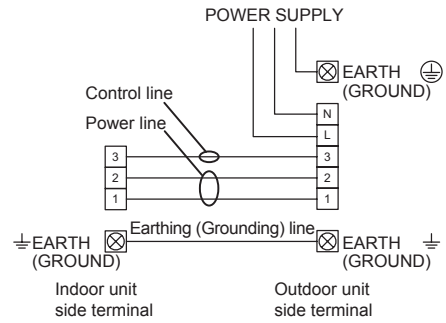

### 6.4.2. Connection cable preparation

Keep the earth (ground) wire longer than the other wires.

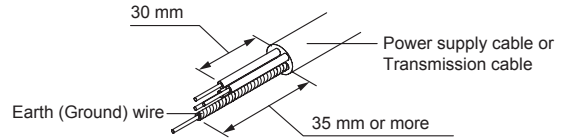

### 6.4.3. Wiring procedure

- (1) Remove the service panel cover, insulation sheet and connect the wires to the terminal in accordance with the terminal nameplate. (Fig. A, Fig. B)

Fig. A

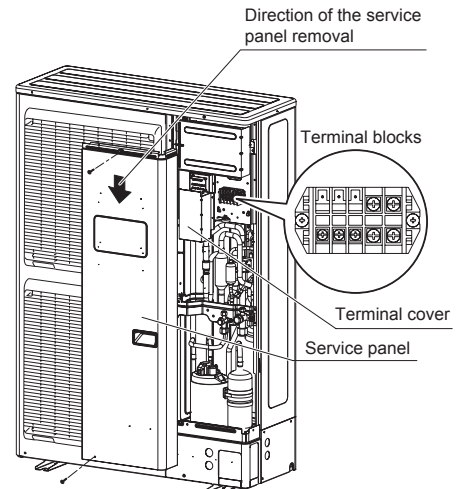

- (2) After connecting the wires, use cable clips to secure the wires. (Fig. B)

- Connect the wires without applying excessive tension.

Fig. B

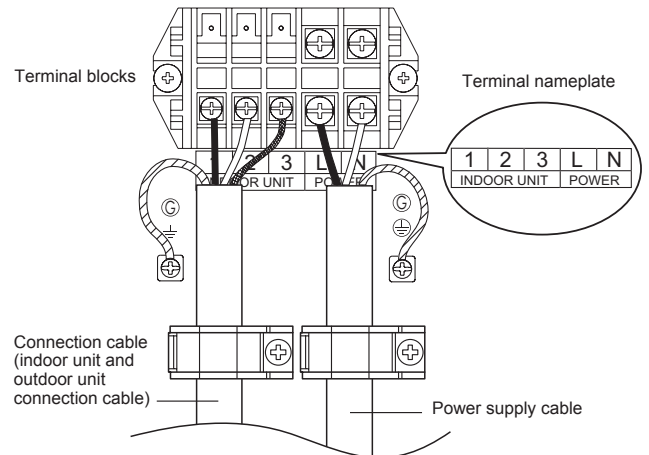

- (3) Secure the cables using the cable clips under the terminal blocks, and then secure the cables using the cable clips attached to the base of the valves.

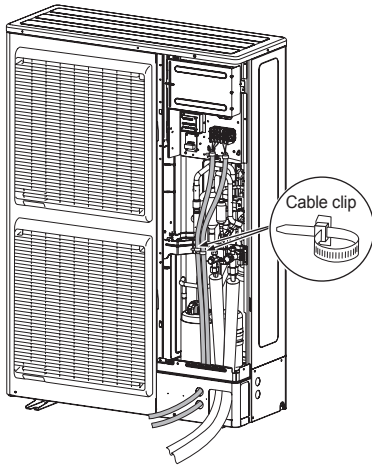

- (4) Be sure to install the insulation sheet after the wiring is complete.

## 7. PIPE INSTALLATION-2

### ⚠ WARNING

Install the insulated pipes so that they do not touch the compressor.

### 7.1. Installing insulation

- Use an insulation on the refrigerant pipes to prevent condensation and dripping. (Fig. A)
- Determine the thickness of the insulation material by referring to Table A.

**Table A, Selection of insulation**  
(for using an insulation material with equal heat transmission rate or below 0.040 W/(m·k))

Relative humidity [mm (in.)]		Insulation material			
		Minimum thickness [mm]			
		70% or more	75% or more	80% or more	85% or more
Pipe diameter	6.35 (1/4)	8	10	13	17
	9.52 (3/8)	9	11	14	18
	12.70 (1/2)	10	12	15	19
	15.88 (5/8)	10	12	16	20
	19.05 (3/4)	10	13	16	21

If the ambient temperature and relative humidity exceed 32 °C, increase the level of heat insulation for the refrigerant pipes.

### 7.2. Filling with putty

### ⚠ WARNING

Fill the piping holes with putty (supplied locally) to avoid any gap (Fig A). If small animals such as insects enter the external unit, a short circuit may be caused near electrical components in the service panel.

If the outdoor unit is installed at a level that is higher than the indoor unit, the water that has condensed in the 3-way valve of the outdoor unit could travel to the indoor unit. Therefore, use putty in the space between the pipe and the insulation to prevent the entry of water.

Fig. A

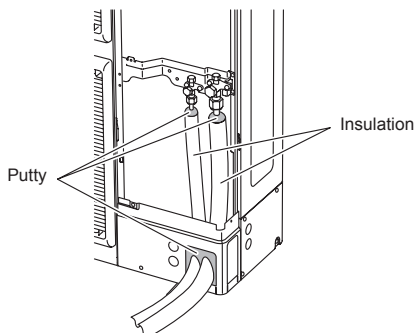

## 8. HOW TO OPERATE DISPLAY UNIT

### 8.1. Display unit position

#### ⚠ WARNING

Never touch electrical components such as the terminal blocks except the button on the display board. It may cause a serious accident such as electric shock.

#### ⚠ CAUTION

Once refrigerant charging is completed, be sure to open the valve prior to performing the local settings. Otherwise, the compressor may fail.

Discharge any static electricity from your body before touching the push buttons. Never touch any terminal or pattern of any parts on the control board.

- The positions of the buttons on the outdoor unit control board are shown in the figure below.
- Various settings can be adjusted by changing Push buttons on the board of the outdoor unit.

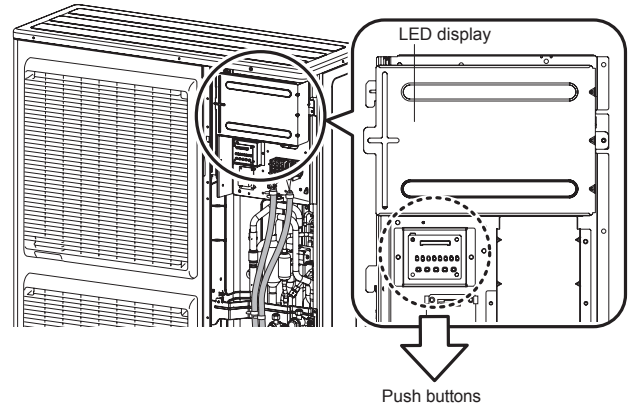

- The printed characters for the LED display are shown below.

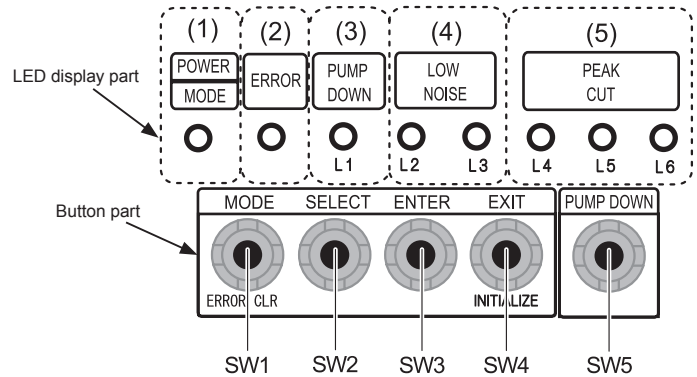

## 8.2. Description of display and button

Display lamp		Function or operation method
(1) POWER / MODE	Green	Lights on while power on. Local setting in outdoor unit or error code is displayed with blink.
(2) ERROR	Red	Blinks during abnormal air-conditioner operation.
(3) PUMP DOWN (L1)	Orange	Lights on during pump down operation.
(4) LOW NOISE MODE (L2, L3)	Orange	Lights on during "Low noise" function when local setting is activated. (Lighting pattern of L2 and L3 indicates low noise level) *See page 12.
(5) PEAK CUT (L4, L5, L6)	Orange	Lights on during "Peak cut" function when local setting is activated. (Lighting pattern of L4, L5 and L6 indicates peak cut level) *See page 12.

Button		Function or operation method
SW1	MODE	To switch between "Local setting" and "Error code display".
SW2	SELECT	To switch between the individual "Local settings" and the "Error code displays".
SW3	ENTER	To fix the individual "Local settings" and the "Error code displays".
SW4	EXIT	To return to "Operation status displays."
SW5	PUMP DOWN	To start the pump down operation.

## 9. FIELD SETTING

### ⚠ CAUTION

Discharge the static electricity from your body before setting up the switches.  
Never touch the terminals or the patterns on the parts that are mounted on the board.

### 9.1. Field setting buttons

- Remove the front panel of the outdoor unit access the print circuit board of the display unit.  
Print circuit board buttons for various settings and LED displays are shown in the figure.

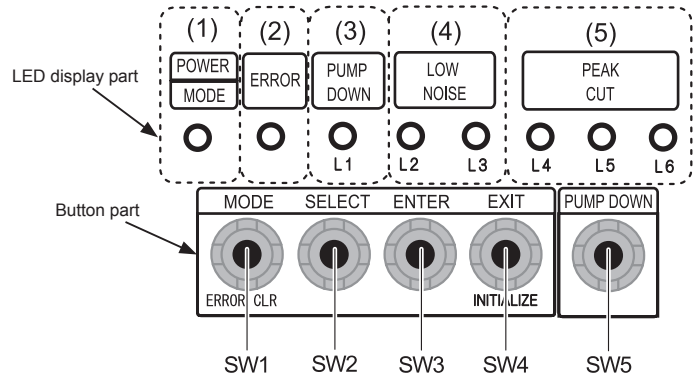

## 9.2. Function settings

- Various functions can be set. Follow the setting method described in 9.2.1. to set as per the requirement.  
Perform these settings after the indoor unit stops.

Table. Settings List

No	Setting Item		LED display							Factory setting	Content	
			POWER MODE	ERROR	PUMP DOWN (L1)	LOW NOISE (L2) (L3)		PEAK CUT (L4) (L5) (L6)				
1	Low noise mode setting	Level 1	Blink (9 times)	○	○	○	●	○	○	●	○	The noise level when operating in the low noise mode can be set. The operation selection can be done by external input terminal(CN10). Cooling/heating performance decreases by lowering operation noise level.
		Level 2	Blink (9 times)	○	○	○	●	○	●	○		
2	Peak cut mode setting	Level 1	Blink (9 times)	○	○	●	○	○	○	●		The capacity limit can be selected when operating with the "Peak Cut mode." The operation selection can be done by external input terminal(CN11). The lower the level, the more the effect of energy saving, but the cooling/heating performance decreases.
		Level 2	Blink (9 times)	○	○	●	○	○	●	○		
		Level 3	Blink (9 times)	○	○	●	○	○	●	●		
		Level 4	Blink (9 times)	○	○	●	○	●	○	○	○	

Sign "○": Lights off, "●": Lights on



### 9.2.1. Setting for low noise mode

- Switch to "Local setting mode" by pressing [MODE] button (SW1) for 3 seconds or more.
- Confirm (POWER / MODE) blinks 9 times, and press [ENTER] button (SW3).

POWER	ERROR	PUMP DOWN (L1)	LOW NOISE (L2) (L3)			PEAK CUT (L4) (L5) (L6)	
MODE							
Blink (9 times)	○	○	○	○	○	○	○

Sign "○": Lights off, "●": Lights on, ( ) : Number of blinking

- Press [SELECT] button (SW2), and adjust LED display as shown below. (Current setting is displayed)

	LOW NOISE (L2) (L3)	
LOW NOISE MODE	○	Blink

Sign "○": Lights off

- Press [ENTER] button (SW3).

	LOW NOISE (L2) (L3)	
LOW NOISE MODE	○	●

Sign "○": Lights off, "●": Lights on

- Press [SELECT] button (SW2), and adjust LED lamp as shown in below figure.

	PEAK CUT (L4) (L5) (L6)		
Level 1	○	○	Blink
Level 2	○	Blink	○

Sign "○": Lights off

The noise of Level 2 is lower than the one of Level 1.

- Press [ENTER] button (SW3) and fix it.

	PEAK CUT (L4) (L5) (L6)		
Level 1	○	○	●
Level 2	○	●	○

Sign "○": Lights off, "●": Lights on

- Return to "Operating status display (Normal operation)" by pressing [EXIT] button (SW4).

- In case of missing how many times [SELECT] and [ENTER] button are pressed, restart from the beginning of operation procedure after returning to "Operation status display (normal operation)" by pressing the [EXIT] button once.

### 9.2.2. Setting for peak cut mode

- Switch to "Local setting mode" by pressing [MODE] button (SW1) for 3 seconds or more.
- Confirm (POWER / MODE) blinks 9 times, and press [ENTER] button (SW3).

POWER	ERROR	PUMP DOWN (L1)	LOW NOISE (L2) (L3)			PEAK CUT (L4) (L5) (L6)	
MODE							
Blink (9 times)	○	○	○	○	○	○	○

Sign "○": Lights off, "●": Lights on, ( ) : Number of blinking

- Press [SELECT] button (SW2), and adjust LED lamp as shown below. (Current setting is displayed)

	LOW NOISE (L2) (L3)	
PEAK CUT MODE	Blink	○

Sign "○": Lights off

- Press [ENTER] button (SW3).

	LOW NOISE (L2) (L3)	
PEAK CUT MODE	●	○

Sign "○": Lights off, "●": Lights on

- Press [SELECT] button (SW2), and adjust LED lamp as shown in below figure.

		PEAK CUT (L4) (L5) (L6)		
Level 1	0% of rated input ratio	○	○	Blink
Level 2	50% of rated input ratio	○	Blink	○
Level 3	75% of rated input ratio	○	Blink	Blink
Level 4	100% of rated input ratio	Blink	○	○

Sign "○": Lights off

- Press [ENTER] button (SW3) and fix it.

		PEAK CUT (L4) (L5) (L6)		
Level 1	0% of rated input ratio	○	○	●
Level 2	50% of rated input ratio	○	●	○
Level 3	75% of rated input ratio	○	●	●
Level 4	100% of rated input ratio	●	○	○

Sign "○": Lights off, "●": Lights on

- Return to "Operating status display (Normal operation)" by pressing [EXIT] button (SW4).

- When pressed number is lost during operation, restart from the beginning of operation procedure after returning to "Operation status display (normal operation)" by pressing the [EXIT] button once.

## 10. EXTERNAL INPUT AND OUTPUT

### 10.1. External input

#### 10.1.1. Wiring of connector

ON/OFF of the "Low noise mode", and "Peak cut mode" functions can be enabled with an external field device.

When installing connection cable, specified part (optional parts) must be used. Refer to section 9.2. Table. Settings List, for the required function. The function must be set for the external input to work.

Input	Connector
Low noise mode	CN10
Peak cut mode	CN11

\* Make the distance from the PC board to the connected unit within 10m (33ft).

- Contact capacity : 24VDC or more, 10mA or more.

Circuit diagram example

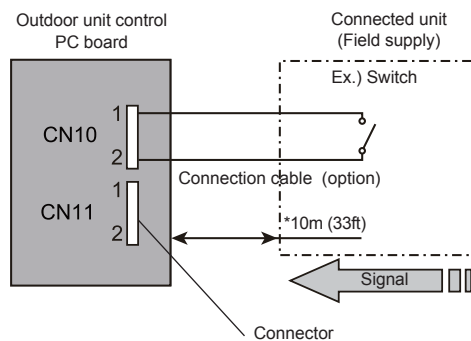

### 10.1.2. Low noise mode (CN10)

This feature reduces the operating sound of the outdoor unit from the normal sound. The air conditioner is set to the "Low noise mode" when closing the contact input of a commercial timer or ON/OFF switch to a connector on the outdoor control PC board.

\* Performance may drop depending on the outside air temperature condition, etc.

\* Set the "Low noise mode" level, refer to "9.2. Function settings".

Input Signal ...ON : Low noise mode  
 ...OFF : Normal operation

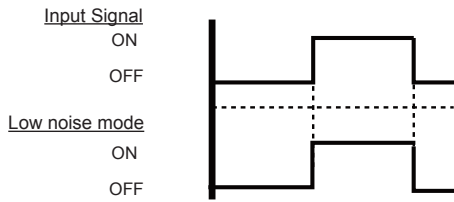

### 10.1.3. Peak cut mode (CN11)

Operation that suppressed the current value can be performed by means of the connected unit. The air conditioner is set to the Peak cut mode by applying the contact input of a commercial ON/OFF switch to a connector on the outdoor control PC board.

\* Set the "Peak cut mode" level, refer to "9.2. Function settings".

Input Signal ...ON : Peak cut mode  
 ...OFF : Normal operation

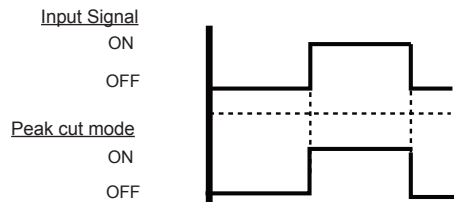

## 10.2. External output

### 10.2.1. Wiring of connector

When installing connection cable, specified part (optional parts) must be used.

Output	Connector
Error status	CN12
Compressor status	CN13

\* Make the distance from the PC board to the connected unit within 10m (33ft).

- 1) Power supply
  - Voltage (Chart sign=Vcc) : DC 24V or less
- 2) Load
  - Load : DC 500mA or less is recommended

Circuit diagram example

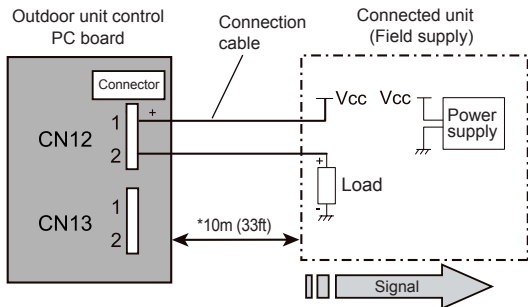

### 10.2.2. Error status output (CN12)

An air conditioner error status signal is produced when a malfunction occurs.

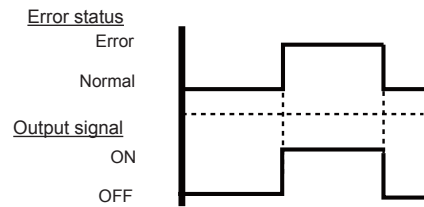

### 10.2.3. Compressor status output (CN13)

Compressor operation status signal is produced when the compressor is running.

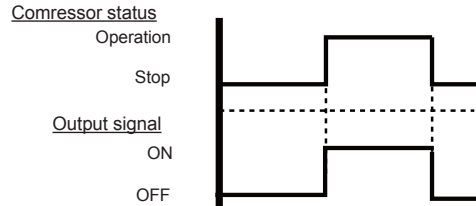

## 11. TEST RUN

### 11.1. Pre-test run check items

Before the test operation, refer to the figure and check the following items.

<input type="checkbox"/> Is the outdoor unit securely installed?
<input type="checkbox"/> Have you performed gas leakage inspection? (Connection joints of various pipes (flange connection, brazing))
<input type="checkbox"/> Is the heat insulation done completely? (Gas pipe, liquid pipe, drain hose extension on indoor unit side etc)
<input type="checkbox"/> Is the water discharging from drain without any problems?
<input type="checkbox"/> Are the cables connected correctly?
<input type="checkbox"/> Are the cables as per specifications?
<input type="checkbox"/> Is the earth wire connected accurately?
<input type="checkbox"/> Are there any obstacles blocking the suction gate, and outlet of the indoor/outdoor units?
<input type="checkbox"/> Have you filled the specified amount of refrigerant?
<input type="checkbox"/> Are the stop valves of gas pipe and liquid pipe fully open?
<input type="checkbox"/> Has the power been supplied to crankcase heater for more than 6 hours?

After checking that the above items are all in order, refer to "11.2. Test operation method" to test operation the unit. If there are problems, adjust immediately and recheck.

## 11.2. Test operation method

Be sure to configure test run settings only when the outdoor unit has stopped operating.

- Depending on the communication status between the indoor and outdoor units, it may take several minutes for the system to start operating after settings for the test run are complete.
- After the test run settings are complete, the outdoor units and the connected indoor units will start operating. Room temperature control will not activate during test operation (continuous operation).
- If a knocking sound can be heard in the liquid compression of the compressor, stop the unit immediately and then energize the crank case heater for a sufficient length of time before restarting the operation.

Test operation setting method (It can be performed in the following two ways)

- Set with test operation setting (refer to installation instructions manual of indoor unit for further details) available in the remote controller.
- "Cooling Operation" and "Heating Operation" can be set using SELECT button and ENTER button available on the board of display unit.

(\*Make sure to perform the first test operation with cooling operation.)

Set as per the procedure given below.

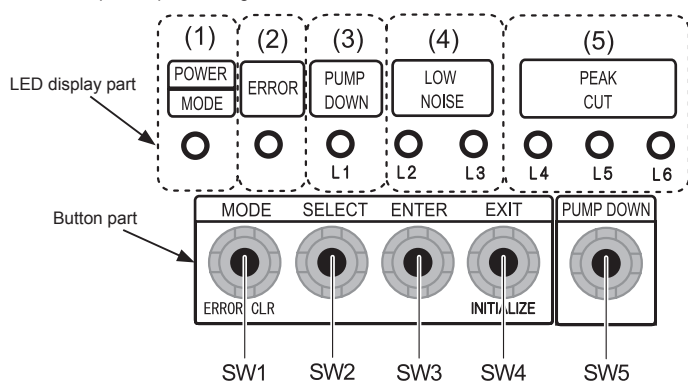

### 11.2.1. Setting method on outdoor unit board

- Turn on the power of the outdoor unit and enter standby mode.  
"POWER/MODE" Lamp lights up.

POWER	ERROR	PUMP DOWN	LOW NOISE		PEAK CUT		
MODE		(L1)	(L2)	(L3)	(L4)	(L5)	(L6)
●	○	○	○	○	○	○	○

Sign "○": Lights off, "●": Lights on

- Press the ENTER button for more than 3 seconds.

POWER	ERROR	PUMP DOWN	LOW NOISE		PEAK CUT		
MODE		(L1)	(L2)	(L3)	(L4)	(L5)	(L6)
Blink	○	○	○	Blink	○	○	○

Sign "○": Lights off, "●": Lights on

- Press the SELECT button, LED of the test run mode Switched between "COOL" and "HEAT".

Cooling test mode

POWER	ERROR	PUMP DOWN	LOW NOISE		PEAK CUT		
MODE		(L1)	(L2)	(L3)	(L4)	(L5)	(L6)
Blink	○	○	○	Blink	○	○	○

Sign "○": Lights off, "●": Lights on

Heating test mode

POWER	ERROR	PUMP DOWN	LOW NOISE		PEAK CUT		
MODE		(L1)	(L2)	(L3)	(L4)	(L5)	(L6)
Blink	○	○	Blink	○	○	○	○

Sign "○": Lights off, "●": Lights on

- After confirming the operation mode, Press ENTER button.  
The display changes as follows, and Air conditioner starts operation.  
Cooling test mode

POWER	ERROR	PUMP DOWN	LOW NOISE		PEAK CUT		
MODE		(L1)	(L2)	(L3)	(L4)	(L5)	(L6)
Blink	○	○	○	●	○	○	○

Sign "○": Lights off, "●": Lights on

Heating test mode

POWER	ERROR	PUMP DOWN	LOW NOISE		PEAK CUT		
MODE		(L1)	(L2)	(L3)	(L4)	(L5)	(L6)
Blink	○	○	●	○	○	○	○

Sign "○": Lights off, "●": Lights on

- Press [ENTER] button.

Air conditioner stopped operation.

POWER	ERROR	PUMP DOWN	LOW NOISE		PEAK CUT		
MODE		(L1)	(L2)	(L3)	(L4)	(L5)	(L6)
●	○	○	○	○	○	○	○

Sign "○": Lights off, "●": Lights on

## 11.3. Checklist

Check items during test operation.

<input type="checkbox"/>	Is the outdoor unit making any abnormal noise or vibrating significantly?
<input type="checkbox"/>	Is the cold air or hot air blowing from indoor unit according to the operation mode?
<input type="checkbox"/>	Check that the "ERROR" LED blinks. If, it has displayed, check the error content as per 12.2. described later.
<input type="checkbox"/>	Operate the unit according to the operating manual provided with the indoor unit, and check that it is operating normally.

## 12. ERROR CODES

You can determine the operating status by the lighting up and blinking of the LED lamp.

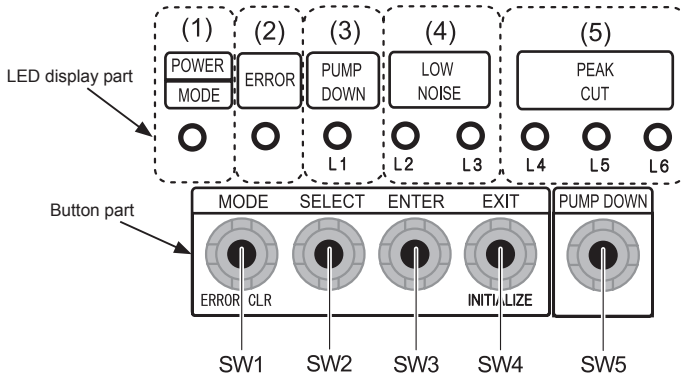

### 12.1. Error display mode

Display when an error occurs.

POWER MODE	ERROR	PUMP DOWN (L1)	LOW NOISE		PEAK CUT		
			(L2)	(L3)	(L4)	(L5)	(L6)
●	Blink (Hi speed)	○	○	○	○	○	○

Sign "○": Lights off, "●": Lights on

- (1) Check that the "ERROR" LED blinks, then press the [ENTER] button once.

### 12.2. Error code check table

POWER/ MODE	ERROR	LED display						DESCRIPTION	REMARK
		PUMP DOWN (L1)	LOW NOISE (L2)	(L3)	PEAK CUT (L4)	(L5)	(L6)		
◆(2)	●	◆(1)	◆(1)	○	○	●	●	Serial communication error	Serial forward transmission error immediately after operation
◆(2)	●	◆(1)	◆(1)	○	●	○	○		Serial forward transmission error during operation
◆(2)	●	◆(2)	◆(2)	○	○	○	●	Indoor unit capacity error	Indoor unit capacity error
◆(2)	●	◆(5)	◆(15)	○	○	○	●	Indoor unit error	Indoor unit error
◆(2)	●	◆(6)	◆(2)	○	○	○	●	Outdoor unit main PCB error	Outdoor unit PCB model information error
◆(2)	●	◆(6)	◆(3)	○	○	○	●	Inverter PCB error	Inverter error
◆(2)	●	◆(6)	◆(5)	○	○	●	●	IPM error	Trip terminal L error
◆(2)	●	◆(7)	◆(1)	○	○	○	●	Discharge temp. sensor error	Discharge temp. sensor 1 error
◆(2)	●	◆(7)	◆(2)	○	○	○	●	Compressor temp. sensor error	Compressor temp. sensor 1 error
◆(2)	●	◆(7)	◆(3)	○	○	●	○	Outdoor unit Heat Ex. sensor error	Heat Ex. middle temp. sensor error
◆(2)	●	◆(7)	◆(3)	○	○	●	●		Outdoor unit Heat Ex. liquid temp. sensor error
◆(2)	●	◆(7)	◆(4)	○	○	○	●	Outdoor temp. sensor error	Outdoor temp. sensor error
◆(2)	●	◆(7)	◆(7)	○	○	○	●	Heat sink temp. sensor error	Heat sink temp. sensor error
◆(2)	●	◆(8)	◆(4)	○	○	○	●	Current sensor error	Current sensor 1 error (stoppage permanently)
◆(2)	●	◆(8)	◆(6)	○	●	○	○	Pressure sensor error	High pressure switch 1 error
◆(2)	●	◆(8)	◆(6)	○	●	●	○		Pressure sensor error
◆(2)	●	◆(9)	◆(4)	○	○	○	●	Trip detection	Trip detection
◆(2)	●	◆(9)	◆(5)	○	○	○	●	Compressor motor control error	Rotor position detection error (stoppage permanently)
◆(2)	●	◆(9)	◆(7)	○	○	●	●	Outdoor unit fan motor 1 error	Duty error
◆(2)	●	◆(9)	◆(8)	○	○	●	●	Outdoor unit fan motor 2 error	Duty error
◆(2)	●	◆(9)	◆(9)	○	○	○	●	4-way valve error	4-way valve error
◆(2)	●	◆(10)	◆(1)	○	○	○	●	Discharge temp. 1 error	Discharge temp. 1 error
◆(2)	●	◆(10)	◆(3)	○	○	○	●	Compressor temp. error	Compressor 1 temp. error
◆(2)	●	◆(10)	◆(5)	○	○	○	●	Pressure error 2	Low pressure error

Display mode ●: Lights on  
○: Lights off  
◆: Blink (0.5s Lights on / 0.5s Lights off)  
( ): Number of flashing

## 13. PUMP DOWN

### ⚠ WARNING

Never touch electrical components such as the terminal blocks except the button on the display board. It may cause a serious accident such as electric shock.

During the pump-down operation, make sure that the compressor is turned off before you remove the refrigerant piping.  
Do not remove the connection pipe while the compressor is in operation with 2-way or 3-way valve open. This may cause abnormal pressure in the refrigeration cycle that leads to breakage and even injury.

### ⚠ CAUTION

Perform the pump down operation before disconnecting any refrigerant pipe or electric cable.

Collect refrigerant from the service port or the 3-way valve if pump down cannot be performed.

In case of a group control system installation, do not turn the power off pump down is completed in all outdoor units.  
(Group control system installation described in "SPECIAL INSTALLATION METHODS" in the installation manual of the indoor unit.)

- Operate [PUMP DOWN] button on the display board in the manner described below.

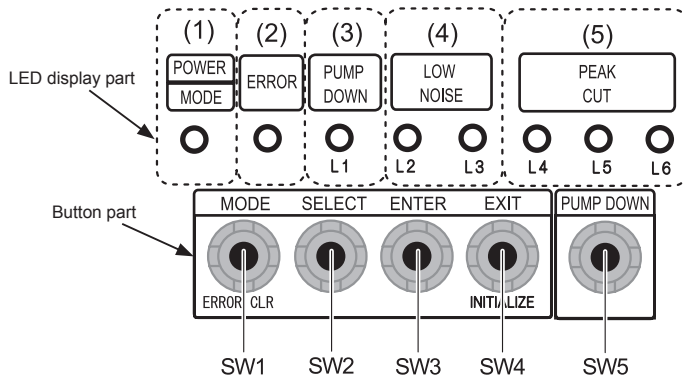

### 13.1. Preparation for pump down

- Confirm that the power is off, and then open the service panel.

### 13.2. Pump down procedure

- Check the 3-way valves (both the liquid side and gas side) are opened.
- Turn the power on.

POWER	ERROR	PUMP DOWN	LOW NOISE		PEAK CUT		
MODE		(L1)	(L2)	(L3)	(L4)	(L5)	(L6)
●	○	○	○	○	○	○	○

Sign "○": Lights off, "●": Lights on

- Press [PUMP DOWN] button for 3 seconds or more after 3 minutes after power on.

POWER	ERROR	PUMP DOWN	LOW NOISE		PEAK CUT		
MODE		(L1)	(L2)	(L3)	(L4)	(L5)	(L6)
●	○	●	○	○	●	●	●

Sign "○": Lights off, "●": Lights on

LED display lights on as shown in the above figure, and the fans and the compressor start operating.

- If the [PUMP DOWN] button is pressed while the compressor is operating, the compressor will stop, then start again in about 3 minutes.

- LED display will change as shown below about 3 minutes after the compressor starts. Fully close the 3-way valve on the liquid pipe side at this stage.

POWER	ERROR	PUMP DOWN	LOW NOISE		PEAK CUT		
MODE		(L1)	(L2)	(L3)	(L4)	(L5)	(L6)
●	○	●	○	○	○	●	●

Sign "○": Lights off, "●": Lights on

- If the valve on the liquid pipe side is not closed, the pump down cannot be performed.

- When LED display changes as shown in the below figure, close the 3-way valve on the gas pipe side tightly.

POWER	ERROR	PUMP DOWN	LOW NOISE		PEAK CUT		
MODE		(L1)	(L2)	(L3)	(L4)	(L5)	(L6)
●	○	●	○	○	○	○	●

Sign "○": Lights off, "●": Lights on

- If the valve on the gas pipe side is not closed, refrigerant may flow into the piping after the compressor stops.

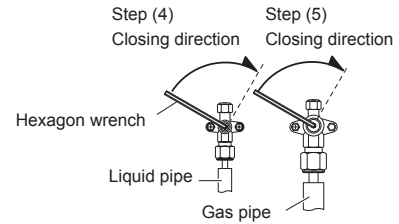

- LED display changes after 1 minute as shown in the figure below.

POWER	ERROR	PUMP DOWN	LOW NOISE		PEAK CUT		
MODE		(L1)	(L2)	(L3)	(L4)	(L5)	(L6)
●	○	●	○	○	○	○	○

Sign "○": Lights off, "●": Lights on

Fans and compressor stop automatically.

- If the pump down is successfully completed (the above LED display is shown), the outdoor unit remains stopped until the power is turned off.

- Turn the power off.

POWER	ERROR	PUMP DOWN	LOW NOISE		PEAK CUT		
MODE		(L1)	(L2)	(L3)	(L4)	(L5)	(L6)
○	○	○	○	○	○	○	○

Sign "○": Lights off

PUMP DOWN is completed.

(Note)

- To stop pump down, press the [PUMP DOWN] button again.
- To start the pump down again after the compressor is automatically stopped due to an error, turn the power off and open the 3-way valves. Wait 3 minutes, turn the power on and start the pump down again.
- When starting the operation after completion of the pump down, turn the power off, and then open the 3-way valves. Wait 3 minutes, turn the power on and perform a test run in the "COOL" operation mode.
- If an error occurs, recover the refrigerant from service port.



