

Installation Manual

R-AQUA HPB 100 R290

Hot Water Heat Pump

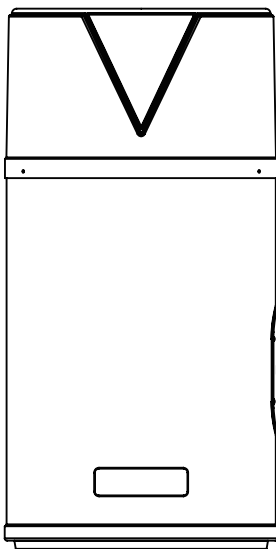

Content

1. Preface	4
2. Safety Instructions	5
3. Unit Dimension (mm).....	9
4. System Schematic.....	11
5. Handling & Installation	13
6. Maintenance	19
7. Parameters	27
8. Wiring Diagram.....	28
9. Display Operation Guide.....	29
10. Failure List & Troubleshooting.....	39

1. Preface

In order to provide customers with high-quality, strong reliable and good versatile products, this heat pump is manufactured by strict design and manufacture standards.

This manual includes all the necessary information about installation, debugging and maintenance. Please read the manual carefully before you start or maintain the unit.

The manufacturer of this product will not be held responsible if someone is injured or the unit is damaged, as a result of improper installation, debugging, unnecessary maintenance which is not in line with this manual.

The unit must be installed by qualified personnel.

It is vital that the below instructions are adhered to at all times to keep the warranty.

—The unit can only be turned on or repaired by a qualified installer or an authorized dealer.

—Maintenance and operation must be carried out according to the recommended time and frequency, as stated in this manual.



—Use standard spare parts only.

Failure to comply with these recommendations will invalidate the warranty.



2. Safety Instructions

The manual provides many important security measures for you to use the air source heat pump water heater. To prevent the users and others from the unpredictable/unexpected hurt of this unit, and avoid damage on the unit or other property, please read the manual carefully before using the unit. All safety measures have safety warnings. The followings are the meanings of each warning:

Mark Notes



Mark	Meaning
 WARNING	A wrong operation may lead to death or grievous injury on people.
 ATTENTION	A wrong operation may lead to harm on people or loss of material.



Icon Notes



Icon	Meaning
	Prohibition. What is prohibited will be nearby this icon.
	Compulsory implement. The listed action need to be taken.
	ATTENTION (include WARNING) Please pay attention to what is indicated.

1. The hurt means no need to be in hospital and cure for a long time, it's injury, burn and get an electric shock.
2. The material lost means property and datum lost.

Warning

Installation	Meaning
 Professional installer is required.	The heat pump must be installed by qualified personals, to avoid improper installation which may lead to water leakage, electrical shock or fire.
 Earthing is required.	Please make sure that the unit and power connection have good earthing, otherwise may cause electrical shock.
 Concentration limits	When install the unit in a small room, please take some measures to prevent the asphyxia caused by the leakage of refrigerant. Please consult the dealer for concrete measures.



Operation	Meaning
 PROHIBITION	DO NOT put fingers or others into the fans and evaporator of the unit, otherwise harm may occur.
 Shut off the power.	When there is something wrong or strange smell, the power supply needs to be shut off to stop the unit. Continue running may cause short circuit or fire.





Move and Repair	Meaning
 Entrust	When the heat pump needs to be moved or installed again, please entrust dealer or qualified person to carry it out. Improper installation will lead to water leakage, electrical shock, injury or fire.
 Entrust	It is prohibited to repair the unit by the user himself, otherwise electrical shock or fire may occur.
 Prohibit	When the heat pump needs to be repaired, please entrust dealer or qualified person to carry it out. Improper movement or repair on the unit will lead to water leakage, electrical shock, injury or fire.









The appliance shall be stored in a room without continuously operating ignition sources (for example: open flames, an operating gas appliance or an operating electric heater.)

ATTENTION



Installation	Meaning
 Installation Place	The unit CANNOT be installed near the flammable gas. Once there is any leakage of the gas, fire may occur.
 Fix the unit.	Make sure that the basement of the heat pump is strong enough, to avoid any decline or fall down of the unit
 Need circuit breaker.	Make sure that there is circuit breaker for the unit, lack of circuit breaker may lead to electrical shock or fire.

Operation	Meaning
 Check the installation basement.	Please check the installation basement regularly (one month), to avoid any decline or damage on the basement, which may hurt people or damage the unit.
 Switch off the power.	Please switch off the power when cleaning or maintenance.
 Prohibition	It is prohibited to use copper or iron as fuse. The right fuse must be fixed by electrician for the heat pump.
 Prohibition	It is prohibited to spray the flammable gas to the heat pump, as it may cause fire.

Usage	Meaning
 <p data-bbox="157 363 320 387">Check the plug</p>	<p data-bbox="376 197 1033 411">The earth electrode of socket should have the perfect earth wiring and the rating current should be more than 16A. Keep the socket and plug dry to avoid leakage and check if they are connected well usually. The check ways are as follow: Put the plug into the socket and turn on the unit, then pull out the plug half an hour later and check if the plug is hot. If it is hot (more than 50 °C), please have a qualified socket to replace it to avoid the burnout or fire caused by the bad contact.</p>
 <p data-bbox="129 563 348 587">Check power socket</p>	<p data-bbox="376 421 1025 611">In the water splashed places and may be on the wall, the installation height of power socket cannot be less than 1.8 meters, to ensure that water does not splash socket, and cannot be installed in the place that children may touch. As the water temperature in the tank is very high (over 50 °C hot water will burn the body), you should adjust a suitable water temperature before spraying to the body.</p>
 <p data-bbox="141 703 309 727">Usage attention</p>	<p data-bbox="376 620 1003 722">If the unit has not been used more than 2 weeks, please turn on the hot water tap for a few minutes. Sometimes there may be an unusual sound like the air passes through the pipe, the sound is normal and please feel free to use.</p>
 <p data-bbox="141 810 337 834">Power line replace</p>	<p data-bbox="376 732 925 810">If the power line are damaged, ask the professional serviceman to use the power line provided by the manufacturer to replace it.</p>
 <p data-bbox="165 919 309 943">Parts replace</p>	<p data-bbox="376 871 997 919">If the parts are damaged, ask the professional serviceman to use the parts provided by the manufacturer to replace it.</p>
 <p data-bbox="174 1031 303 1054">Save labels</p>	<p data-bbox="376 975 958 1031">Do not tear down any permanent instructions, labels or parameters panel of the heater.</p>

3. Unit Dimension (mm)

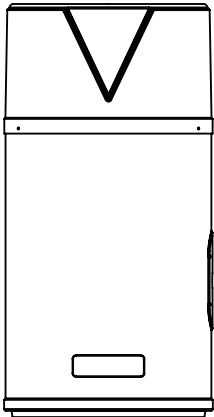
Packing list About the Box

 A line drawing of a rectangular heat pump water heater unit. It features a V-shaped vent pipe at the top, a horizontal line indicating a panel or door, and a small rectangular access panel near the bottom. The unit is shown from a front-facing perspective.	<p>Heat Pump Water Heater × 1</p>
 A photograph of a brass pressure release valve. It has a black plastic handle on top, a side inlet/outlet, and a main outlet. A circular logo is visible on the side of the valve.	<p>Pressure Release valve × 1</p>

Dimensions

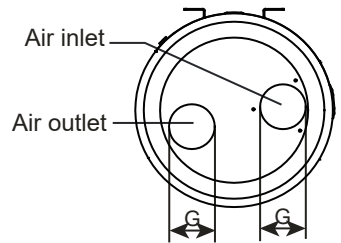
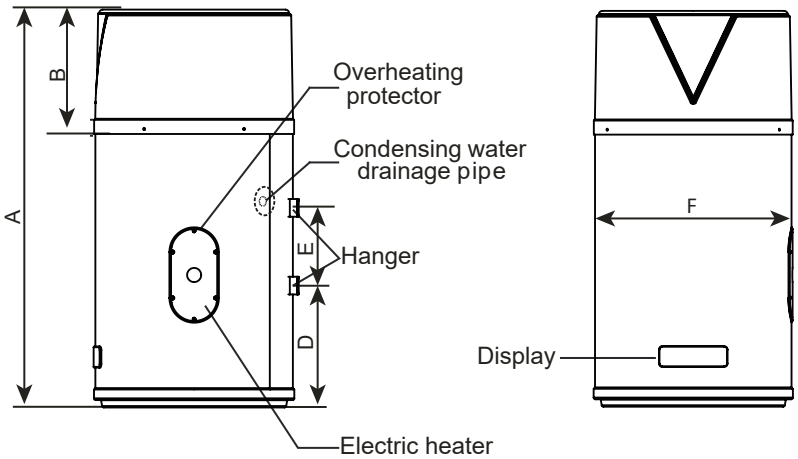
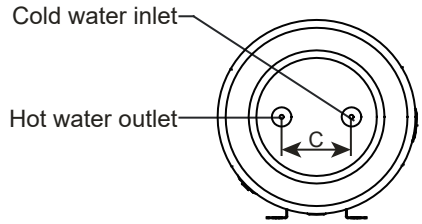

Unit:mm

DIM \ Model	HPB100(R290)
A	1117
B	352
C	200
D	305
E	275
F	φ560
G	φ125

4. System Schematic

Installation position

1) Installation in a non-ducted configuration

- ✓ Unheated location at temperatures above 5°C and isolated from the heated rooms of the house.
- ✓ Recommended location = underground or semi-underground, room where the temperature is higher than 10°C all year round.

Examples of locations:

- Garage: recovery of free calories released from appliances in operation.
- Laundry room: Dehumidification of the room and recovery of lost calories from washing machines and dryers.

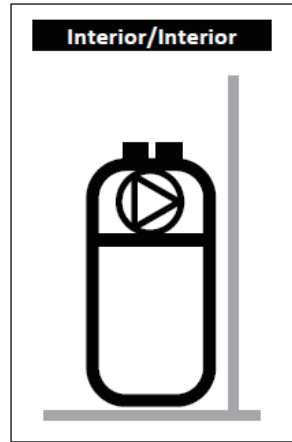

Ensure these minimum spaces indicated to avoid recirculating the air.

2) Installation in ducted configuration (2 ducts).

- ✓ Location is at least frost-free ($T > 1^{\circ}\text{C}$).
- ✓ Recommended location: living space (the thermal losses of the water heater are not lost), near the outer walls. Avoid placing the water heater and/or the ducts close to bedrooms for sound comfort.

Examples of locations:

- Laundry room,
- Cellar,
- Entry hall cupboard

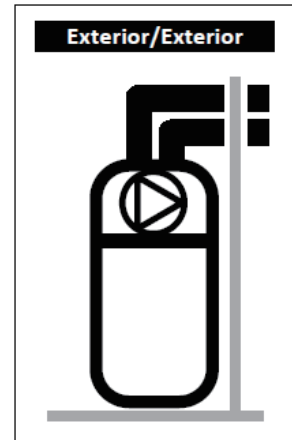

Respect the maximum lengths of ducting. Use rigid or semi-rigid insulated ducts. Provide grills on the air inlet and output to avoid and foreign objects entering. Attention, air inlet and outlet grills which can be manually obstructed are forbidden.

3) Installation in semi-ducted configuration (1 discharge duct).

- ✓ Unheated location at temperatures above 5°C and isolated from the heated rooms of the house.
- ✓ Recommended location = underground or semi-underground, room where the temperature is higher than 10°C all year round

Examples of locations:

- Garage: recovery of free calories released by the car engine when it is shut down after operation, or other household appliances in operation.
- Laundry room: Dehumidification of the room and recovery of lost calories from washing machines and dryers.

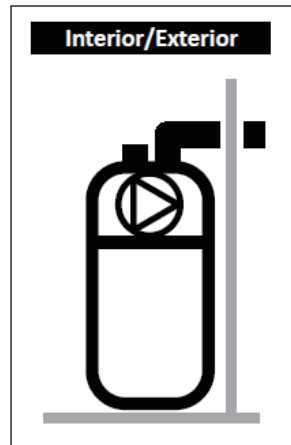

5. Handling & Installation

5.1. Installation Site Requirement (Unit: mm)

Please ensure that you leave the space as shown below for maintenance

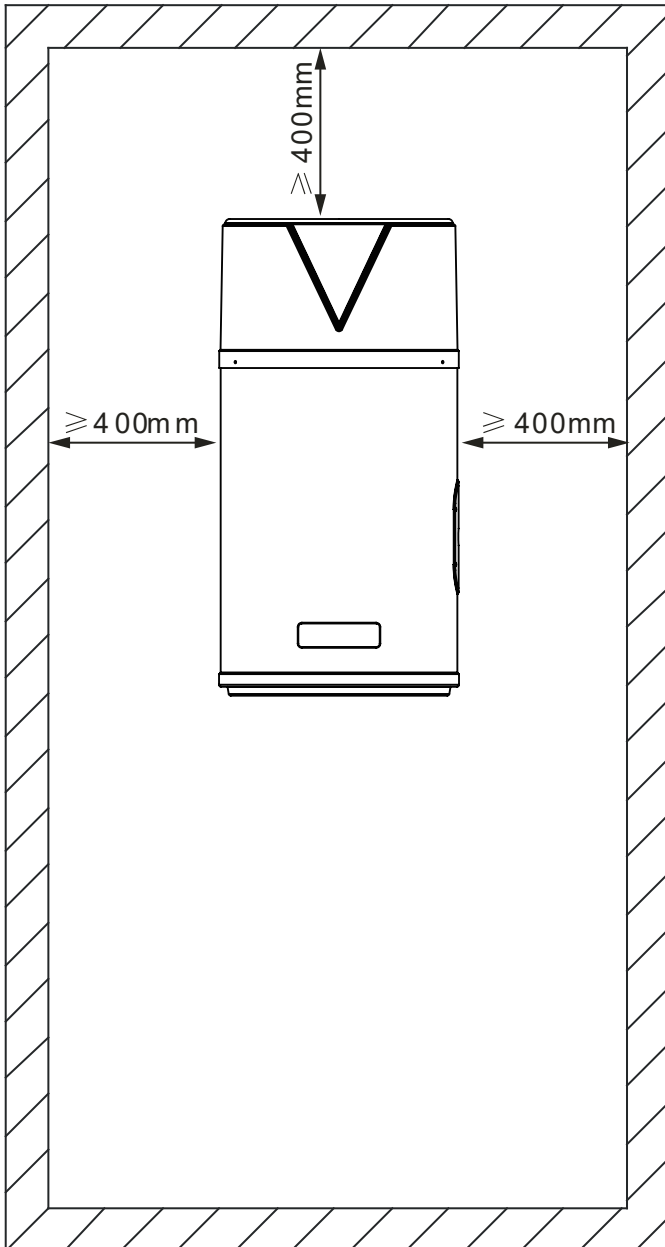

Choice of the installation site of the unit

Warning: The heat pump must be installed by qualified person to avoid improper installation which will lead to water leakage, electrical shock or fire. All working procedure that affects safety should only be carried by competent persons.

- 1) The water heater can be installed indoors . Recommend the installation in the storeroom or basement.
- 2) If the installation site is with heavy wind, put the unit in a suitable place to avoid the bad effect caused by the strong wind. Prevent the water heater from blowing down is necessary.
- 3) Choose the place that there are no directly to the sunlight and other heat radiating. If you cannot avoid it, please install coverings to prevent the sunlight.
- 4) When the air inlet and outlet are not connected to the duct, please make sure no barriers near it. Air outlet could be connected to the air duct to bring fresh cool air into the rooms. If this measure is carried out, a reversing valve should be installed in the air duct to make the cool air blows to outdoors in winter. The air inlet could be connected the rooms with the air duct to draft the air from and keep fresh air in the rooms.
- 5) Provide the sufficient space which is dry and drafty for installation and maintenance.
- 6) The supporting surface should be flat(horizontal angle $\leq 2^\circ$), and it could withstand the weight of water heater. The unit should be installed vertically, and will not cause much noise and vibration.
- 7) Operating noise and elimination air could not affect neighbors.
- 8) The place without the combustible gas.
- 9) The place convenient for pipe connection and electrical wiring.
- 10) There must be electrical insulation between the unit and location site if the site is with a metal part, and such electrical insulation must meet the requirements of the relevant electrical standards.
- 11) The appliance shall be stored in a room without continuously operating ignition sources (for example: open flames, an operating gas appliance or an operating electric heater.)
- 12) The appliance shall be stored in a well-ventilated area where the room size corresponds to the room area as specified for operation.
- 13) Appliance shall be installed, operated and stored in a room with a floor area larger than 7m².
- 14) Leave a space of 500mm in front of the electrical equipment and 300mm in front of the hydraulic equipment so that the water heater is

accessible for its periodic servicing.

15) Please make a perfect installation. Any poor installation will lead to vibration and noise.

16) Spaces where refrigerant pipes shall be compliance with national gas regulations

17) Do not pierce or burn.

18) Do not use means to accelerate the defrosting process or to clean, other than those recommended by the manufacturer.

ATTENTION: The following installation site would lead to machine malfunction (Prior consultation is necessary if the following site is unavoidable.)

The place in which the air is filled with mineral oil;

The place in which the air is in high salinity, like seaside;

The place in which the air is filled with corrosive gas, like hot spring areas;

The place with serious voltage fluctuation, like factory;

The place inside a car or a cabin;

The place in which the air is filled with oil, like kitchen;

The place with strong electromagnetic wave;

The place in which the air is filled with inflammable gas/material;

The place in which the air is filled with acidity or alkalinity gas;

Other special places just like the above.

Transport of equipment containing flammable refrigerants

Compliance with the transport regulations

Marking of equipment using signs

Compliance with local regulations

Disposal of equipment using flammable refrigerants

Compliance with national regulations

Storage of equipment/appliances

The storage of equipment should be in accordance with the manufacturer's instructions.

Storage of packed (unsold) equipment

Storage package protection should be constructed such that mechanical damage to the equipment inside the package will not cause a leak of the refrigerant charge. The maximum number of pieces of equipment permitted to be stored together will be determined by local regulations.

In winter, the air entering through the air inlet can cool the room.

5.2. Hydraulic connection

Please notice the points below when connecting the water pipes:

- Try best to decrease the resistance in water pipes.
- Inner surface of whole pipe system should be clean, no rusty spots and dirt to avoid any pipe jam. After connecting pipes, please check the leakage status of whole system to assure there is no leakage firstly and then make the insulation.
- Add one-way valve, Pressure release valve and other safety valve in water way.
- The installation of water pipes have to be accordance with the requirements of the local standard (To avoid too higher water pressure, please install a discharge valve).
- When connecting the water pipes, please prevent any pollution going into pipes.
- If the discharge outlet of Pressure release valve is drainage hosepipe, please assure its direction is down and its outlet is opened to the air. At the same time, the valve should be in no-frosting surroundings.

Pipeline connection sketch (see picture below)

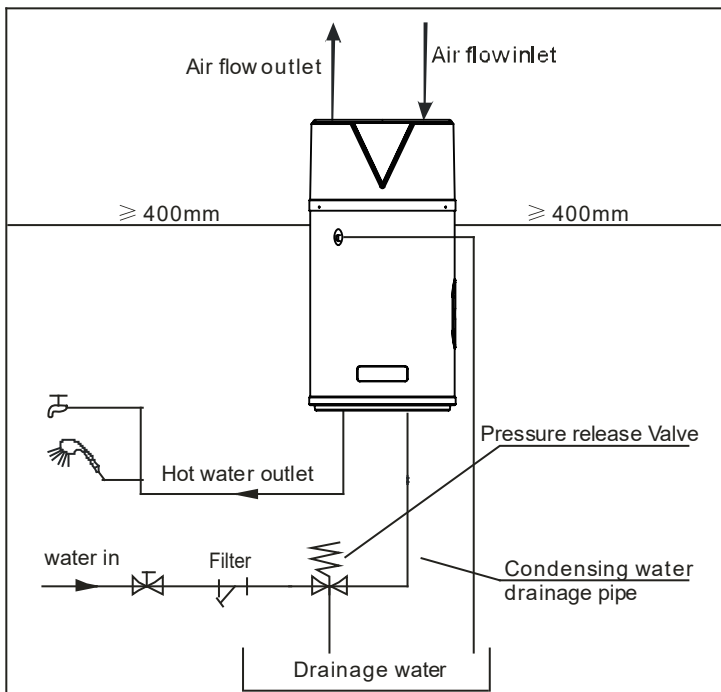

Attention:

After installing the connecting pipe according to the diagram, open the water tap and the hot water switch of the unit, make the water pour into the unit. Then there will be a large amount of air draining off from the hot water switch(This process will lasts for 5-20minutes).When there is just water outflow but no air outflow, it suggests that the unit is full of water, the air is completely drained off. Close all the hot water taps, turn on the hot water heat pump and the installation finish.

It is mandatory to provide the unit with a pressure release valve. Failure to do so will cause damage to the unit, and possible personal injury.

Do not use stainless steel fittings to connect directly with other metals to prevent galvanic corrosion.

Drain the water tank through the drain valve at the bottom part of the unit.

Do not dismantle the pressure release valve.

Do not block off the Drainpipe, it may cause an explosion and/or injury.

5.3. Wire connection

The wire should be placed orderly, reasonable and in accordance with national wiring rules.

Appliances should be installed in accordance with national wiring rules.

The lower part of the unit is equipped with the power plug line for connected to the power unit.

When the unit connect to other circuit, there must be circuit breaker or protector for the unit circuit.

If the power wire has been destroyed, the new wire must get the same certification with the old one, or provided by the factory.

5.4. Deposited and transportation

Generally, it's better to use a container to transport hot water heat pumps and store them in a suitable and dry place. To short distance carrying, please be careful and the maximum inclination is no more than 60°. During transportation and storage, the ambient temp is better from 0°C~40°C. The storage of equipment should be in accordance with the manufacturer's instructions.

Transported by forklift

When using forklift to carry the unit which must have a pallet, the operator should try best to keep the height of forklift at a lowest level. Because the top part is heavier, the operator needs to take measures to prevent its overturn. To avoid any damages, the unit must stand on a flat place.

Transport for installation

When transporting for installation, the bottom of unit needs to be added with pallet and use a rope or belt to fix it well. By this manual carrying or forklift transportation, the inclination is no more than 60° as the following picture shows. If the inclination unavoidably exceeds 60°, the unit must be kept at vertical status for at least 1 hour and then can be started for testing or running.

In order to avoid scratch or deformation of the unit surface, apply guard boards to the contacting surface.

No contact of fingers and other things with the vanes.

Don't incline the unit more than 60° in moving, and keep it vertical when installing.

This unit is heavy, it need to be carried by two or more persons, otherwise might cause injury and damage.

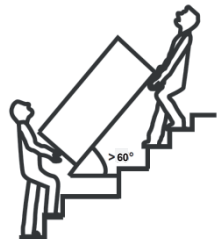

6. Maintenance

WARNING:

Servicing shall be performed only as recommended by the manufacturer.

The local assembly should be the ones designated by manufacturer.

The power cable connection should be complied with the local rules.

If you need to remove or reinstall the unit, please ask the qualified person to make it to avoid improper installation which will lead to water leakage, electrical shock or fire.

The heat pump should be maintained by qualified person to avoid improper maintenance which will lead to water leakage, electrical shock or fire.

ATTENTION:

It should keep dry, clean and well-ventilated around the units to maintain its good effect of heat transfer and energy saving.

Check the parts of the unit and the pressure of the system regularly (once 1 year). If there is any unusual phenomena, repair and replace it immediately.

Check if the electrical wiring is not firm enough and the electrical element has any unusual action and smell. If so, repair and replace it immediately.

Do not make the unit power off if the unit is not used for a long time. We will not be responsible for any lost caused by the frost crack of parts due to the long time power off.

Check if the power socket and plug have a good contacting, perfect earthing and thermal protections.

In the cold area (below 0 °C), if you do not use the unit for a long time, please drain the water in the tank to avoid the damage due to freeze.

It is recommended that the set temperature can be set lower when there is enough hot water for daily life to save energy and extend the service life of water heater.

The safety cable specification is 5A/250VAC, and must meet the explosion-proof requirements.

Be aware that refrigerants may not contain odour.

Water quality shall meet the following conditions.

Water heater system	Total Dissolved Solids (TDS) mg/L or ppm	Hardness (as CaCO ₃) mg/L or ppm	Saturation index (Langelier)	PH	Dissolved Co ₂ mg/L or ppm	Chlorides mg/L or ppm
	2500*	200	+0.4to-1.0 @65°C	6.5 to 9.5	N/A	N/A
<p>*For TDS levels up to and including 800mg/liter the magnesium based anode is to be used. It is recommended that magnesium anode be checked annually. This is the anode fitted during manufacture of the cylinder. For TDS levels greater than 800mg/liter and not exceeding 2500mg/liter the magnesium-based anode is to be used. Frequently inspection of magnesium anode is recommended. This anode Can be fitted by an authorized person. This Warranty does not apply if the TDS exceeds 2500 mg/liter.</p>						

Information on Maintenance and servicing:

- 1) Checks to the area
Prior to beginning work on systems containing flammable refrigerants, safety checks are necessary to ensure that the risk of ignition is minimized. For repair to the refrigerating system, the following precautions shall be complied with prior to conducting work on the system
- 2) Work procedure
Work shall be undertaken under a controlled procedure so as to minimize the risk of a flammable gas or vapour being present while the work is being performed
- 3) General work area
All maintenance staff and others working in the local area shall be instructed on the nature of work being carried out. Work in confined spaces shall be avoided. The area around the workspace shall be sectioned off. Ensure that the conditions within the area have been made safe by control of flammable material.
- 4) Checking for presence of refrigerant
The area shall be checked with an appropriate refrigerant detector prior to and during work, to ensure the technician is aware of potentially flammable atmospheres. Ensure that the leak detection equipment being used is suitable for use with flammable refrigerants, i.e. non-sparking, adequately sealed or intrinsically safe.
- 5) Presence of fire extinguisher
If any hot work is to be conducted on the refrigeration equipment or any associated parts appropriate fire extinguishing equipment shall be available to hand. Have a dry powder or CO₂ fire extinguisher adjacent

If any hot work is to be conducted on the refrigeration equipment or any associated parts appropriate fire extinguishing equipment shall be available to hand. Have a dry powder or CO2 fire extinguisher adjacent to the charging area

6) No ignition sources

No person carrying out work in relation to a refrigeration system which involves exposing any pipe work that contains or has contained flammable refrigerant shall use any sources of ignition in such a manner that it may lead to the risk of fire or explosion. All possible ignition sources, including cigarette smoking, should be kept sufficiently far away from the site of installation, repairing, removing and disposal, during which flammable refrigerant can possibly be released to the surrounding space. Prior to work taking place, the area around the equipment is to be surveyed to make sure that there are no flammable hazards or ignition risks. "No Smoking" signs shall be displayed

7) Ventilated area

Ensure that the area is in the open or that it is adequately ventilated before breaking into the system or conducting any hot work. A degree of ventilation shall continue during the period that the work is carried out. The ventilation should safely disperse any released refrigerant and preferably expel it externally into the atmosphere.

8) Checks to the refrigeration equipment

Where electrical components are being changed, they shall be fit for the purpose and to the correct specification. At all times the manufacturer's maintenance and service guidelines shall be followed. If in doubt consult the manufacturer's technical department for assistance.

The following checks shall be applied to installations using flammable refrigerants

-The charge size is in accordance with the room size within which the refrigerant containing parts are installed:

-The ventilation machinery and outlets are operating adequately and are not obstructed;

- If an indirect refrigerating circuit is being used, the secondary circuit shall be checked for the presence of refrigerant;

-Marking to the equipment continues to be visible and legible. Markings and signs that are illegible shall be corrected;

-Refrigeration pipe or components are installed in a position where they are unlikely to be exposed to any substance which may corrode refrigerant containing components, unless the components are constructed of materials which are inherently resistant to being corroded or are suitably protected against being so corroded.

9) Checks to electrical devices

Repair and maintenance to electrical components shall include initial safety checks and component inspection procedures. If a fault exists that could compromise safety, then no electrical supply shall be connected to the circuit until it is satisfactorily dealt with. If the fault cannot be corrected immediately but it is necessary to continue operation, an adequate temporary solution shall be used. This shall be reported to the owner of the equipment so all parties are advised. Initial safety checks shall include:

That capacitors are discharged: this shall be done in a safe manner to

- avoid possibility of sparking,
- That there no live electrical components and wiring are exposed while charging, recovering or purging the system;
- That there is continuity of earth bonding.

Repairs to sealed components

1) During repairs to sealed components, all electrical supplies shall be disconnected from the equipment being worked upon prior to any removal of sealed covers, etc. If it is absolutely necessary to have an electrical supply to equipment during servicing, then a permanently operating form of leak detection shall be located at the most critical point to warn of a potentially hazardous situation.

2) Particular attention shall be paid to the following to ensure that by working on electrical components, the casing is not altered in such a way that the level of protection is affected. This shall include damage to cables, excessive number of connections, terminals not made to original specification, damage to seals, incorrect fitting of glands, etc. Ensure that apparatus is mounted securely.

Ensure that seals or sealing materials have not degraded such that they no longer serve the purpose of preventing the ingress of flammable atmospheres. Replacement parts shall be in accordance with the manufacturer's specifications.

NOTE: The use of silicon sealant may inhibit the effectiveness of some types of leak detection equipment. Intrinsically safe components do not have to be isolated prior to working on them

Repair to intrinsically safe components

Do not apply any permanent inductive or capacitance loads to the circuit without ensuring, that this will not exceed the permissible voltage and current permitted for the equipment in use.

Intrinsically safe components are the only types that can be worked on while live in the presence of a flammable atmosphere. The test apparatus

shall be at the correct rating. Replace components only with parts specified by the manufacturer. Other parts may result in the ignition of refrigerant in the atmosphere from a leak

Cabling

Check that cabling will not be subject to wear, corrosion, excessive pressure, vibration, sharp edges or any other adverse environmental effects. The check shall also take into account the effects of aging or continual vibration from sources such as compressors or fans.

Detection of flammable refrigerants

Under no circumstances shall potential sources of ignition be used in the searching for or detection of refrigerant leaks. A halide torch (or any other detector using a naked flame) shall not be used.

Leak detection methods

The following leak detection methods are deemed acceptable for systems containing flammable refrigerants.

Electronic leak detectors shall be used to detect flammable refrigerants, but the sensitivity may not be adequate, or may need re-calibration. (Detection equipment shall be calibrated in a refrigerant-free area.) Ensure that the detector is not a potential source of ignition and is suitable for the refrigerant used. Leak detection equipment shall be set at a percentage of the LFL of the refrigerant and shall be calibrated to the refrigerant employed and the appropriate percentage of gas (25 % maximum) is confirmed.

Leak detection fluids are suitable for use with most refrigerants but the use of detergents containing chlorine shall be avoided as the chlorine may react with the refrigerant and corrode the copper pipe-work

If a leak is suspected, all naked flames shall be removed/ extinguished

If a leakage of refrigerant is found which requires brazing, all of the refrigerant shall be recovered from the system, or isolated (by means of shut off valves) in a part of the system remote from the leak. Oxygen free nitrogen (OFN) shall then be purged through the system both before and during the brazing process.

Removal and evacuation

When breaking into the refrigerant circuit to make repairs - or for any other purpose conventional procedures shall be used. However, it is important that best practice is followed since flammability is a consideration. The following procedure shall be adhered to:

Remove refrigerant;

Purge the circuit with inert gas;

Evacuate:

Purge again with inert gas;

Open the circuit by cutting or brazing.

The refrigerant charge shall be recovered into the correct recovery cylinders. The system shall be "flushed" with OFN to render the unit safe. This process may need to be repeated several times. Compressed air or oxygen shall not be used for this task. Flushing shall be achieved by breaking the vacuum in the system with OFN and continuing to fill until the working pressure is achieved, then venting to atmosphere, and finally pulling down to a vacuum. This process shall be repeated until no refrigerant is within the system. When the final OFN charge is used, the system shall be vented down to atmospheric pressure to enable work to take place. This operation is absolutely vital if brazing operations on the pipe-work are to take place.

Ensure that the outlet for the vacuum pump is not close to any ignition sources and there is ventilation available.

Charging procedures

In addition to conventional charging procedures, the following requirements shall be followed

- Ensure that contamination of different refrigerants does not occur when using charging equipment. Hoses or lines shall be as short as possible to minimise the amount of refrigerant contained in them.
- Cylinders shall be kept upright.
- Ensure that the refrigeration system is earthed prior to charging the system with refrigerant.
- Label the system when charging is complete (if not already).
- Extreme care shall be taken not to overfill the refrigeration system.

Prior to recharging the system it shall be pressure tested with OFN. The system shall be leak tested on completion of charging but prior to commissioning. A follow up leak test shall be carried out prior to leaving the site.

Decommissioning

Before carrying out this procedure, it is essential that the technician is completely familiar with the equipment and all its detail. It is recommended good practice that all refrigerants are recovered safely. Prior to the task being carried out, an oil and refrigerant sample shall be taken in case analysis is required prior to re-use of reclaimed refrigerant. It is essential that electrical power is available before the task is commenced.

- a) Become familiar with the equipment and its operation.
- b) Isolate system electrically
- c) Before attempting the procedure ensure that:

Mechanical handling equipment is available, if required, for handling

refrigerant cylinders:

- All personal protective equipment is available and being used correctly;
 - The recovery process is supervised at all times by a competent person;
 - Recovery equipment and cylinders conform to the appropriate standards.
- d) Pump down refrigerant system, if possible
- e) If a vacuum is not possible, make a manifold so that refrigerant can be removed from various parts of the system
- f) Make sure that cylinder is situated on the scales before recovery takes place
- g) Start the recovery machine and operate in accordance with manufacturer's instructions.
- h) Do not overfill cylinders. (No more than 80 % volume liquid charge).
- i) Do not exceed the maximum working pressure of the cylinder, even temporarily
- j) When the cylinders have been filled correctly and the process completed, make sure that the cylinders and the equipment are removed from site promptly and all isolation valves on the equipment are closed off
- k) Recovered refrigerant shall not be charged into another refrigeration system unless it has been cleaned and checked

Labelling

Equipment shall be labelled stating that it has been de-commissioned and emptied of refrigerant. The label shall be dated and signed. Ensure that there are labels on the equipment stating the equipment contains flammable refrigerant.

Recovery

When removing refrigerant from a system, either for servicing or decommissioning, it is recommended good practice that all refrigerants are removed safely.

When transferring refrigerant into cylinders, ensure that only appropriate refrigerant recovery cylinders are employed. Ensure that the correct number of cylinders for holding the total system charge is available. All cylinders to be used are designated for the recovered refrigerant and labelled for that refrigerant (i.e. special cylinders for the recovery of refrigerant). Cylinders shall be complete with pressure relief valve and associated shut-off valves in good working order. Empty recovery cylinders are evacuated and, if possible, cooled before recovery occurs.

The recovery equipment shall be in good working order with a set of instructions concerning the equipment that is at hand and shall be suitable for the recovery of flammable refrigerants. In addition, a set of calibrated weighing scales shall be available and in good working order. Hoses shall be complete with leak-free disconnect couplings and in good

condition. Before using the recovery machine, check that it is in satisfactory working order, has been properly maintained and that any associated electrical components are sealed to prevent ignition in the event of a refrigerant release. Consult manufacturer if in doubt.

The recovered refrigerant shall be returned to the refrigerant supplier in the correct recovery cylinder, and the relevant Waste Transfer Note arranged. Do not mix refrigerants in recovery units and especially not in cylinders.

If compressors or compressor oils are to be removed, ensure that they have been evacuated to an acceptable level to make certain that flammable refrigerant does not remain within the lubricant. The evacuation process shall be carried out prior to returning the compressor to the suppliers. Only electric heating to the compressor body shall be employed to accelerate this process. When oil is drained from a system, it shall be carried out safely

7. Parameters

Model		HPB 100 (R290)
Power Supply	/	220V-240V~/50Hz
Moisture Resistance	IPX	IPX1
Electrical Shockproof	I	I
Heating Capacity Range	kW	0.9
Heating Power Input Range	kW	0.25
Heating Current Input Range	A	1.1
Auxiliary E-heater	kW	1.5
Max. Power Input	kW	1.9
Max. Current Input	A	8.3
Refrigerant / Proper Input	/	R290 / 150g
Unit Dimension(L/W/H)	mm	Φ560×1117
Rated Outlet Water Temperature	℃	55
Air Volume	m ³ /h	250
Air Pressure	Pa	20
Air Duct Diameter	mm	Φ125
Water Inlet/Outlet Size	inch	1/2"
Net Weight	kg	62
Compressor	/	Rotary

Measurement conditions: Instant heating: Ambient temperature 20℃/15℃, Water inlet 15℃ Water outlet 55℃.

Work range:

(1). Ambient temperature is -5℃~43℃ (Heat Pump).

(2). The max temperature of water tank is 60℃.

Operating parameters:

The range of the operating water temperatures: 10~60℃. The range of the operating water pressures: 0.15~0.7MPa.

8. Wiring Diagram

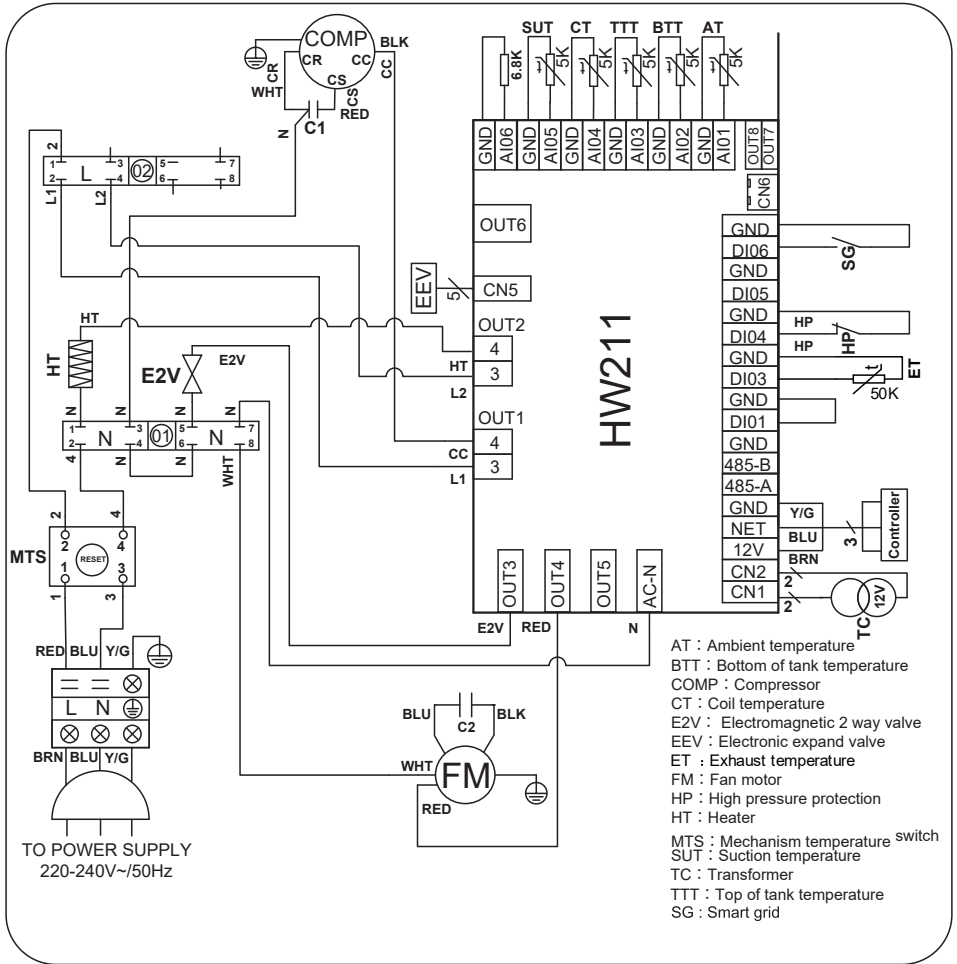



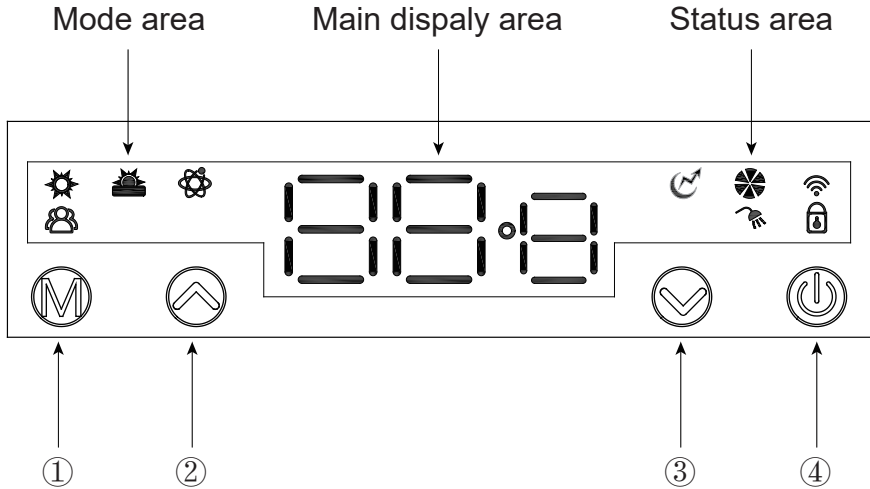

The type of fuse is 5x20_5A/250VAC

9. Display Operation Guide









9.1. Function of wire controller



1) Function of key

NO.	Button	Name	Function
1		Mode	Switch unit running modes or save setting parameters.
2		Up	Move up or increase parameter values.
3		Down	Move down or decrease parameter values.
4		ON/OFF	Turn on/off the unit.

2) Function of display

Status icon	Name	What it means
	Standard heating mode	Shows that the unit is in Standard heating mode.
	Eco heating mode	Shows that the unit is in eco heating mode
	Intelligent heating mode	Shows that the unit is in Intelligent heating mode
	High demand heating mode	Shows that the unit is in High demand heating mode
	Electric heater	Shows that the electric heater is on
	Fan	Shows that the fan is on and the speed of the fan
	WiFi	Shows that the WiFi connection
	Set temperature achieved	Shows that the water temperature has reached the target point and the unit shut off automatically
	Lock	Shows that the keyboard is locked

9.2 Usage of wire controller

9.2.1 Turn ON/OFF the unit

Press "  " and hold for 0.5s in the standby interface of the wire controller to turn on the unit and at this time the main display area shows the water outlet temperature.

Press "  " and hold for 0.5s in the running interface of the wire controller to turn off the unit and at this time the main display area shows OFF.

Note: The ON/OFF button can only be used to turn on/off the unit in standby or running interface of the wire controller.

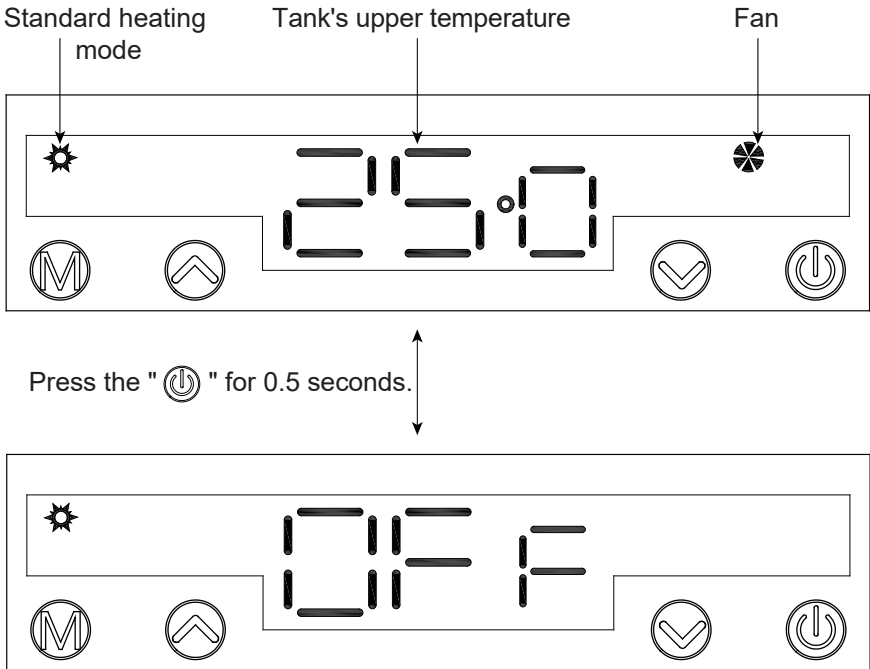

9.2.2 Mode selection

Press "  " to select Standard heating mode, Eco heating mode, Intelligent heating mode and High demand heating mode in power-on state and power-off state.

Example:

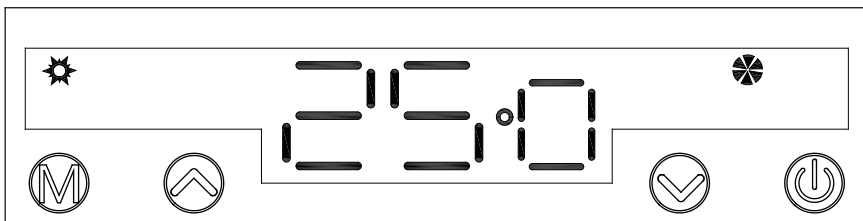

Standard heating mode

We also call standard heating mode. The heat pump system will start according to the actual temperature and target temperature. The electric heater will not start immediately. After R06 time, the controller will judge if it reaches target temperature. If not, the electric heater will start.

Press the “M”
↓

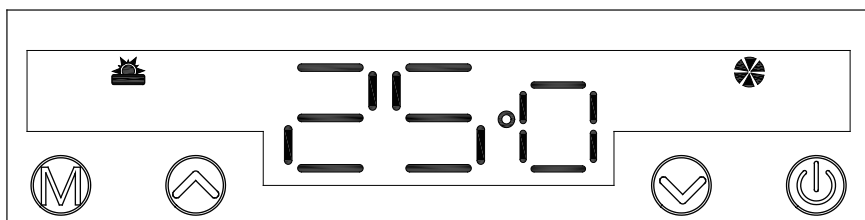

Eco heating mode

The heat pump system will start according to the actual temperature and target temperature. But the electric heater will be off all the time.

Press the “M”
↓

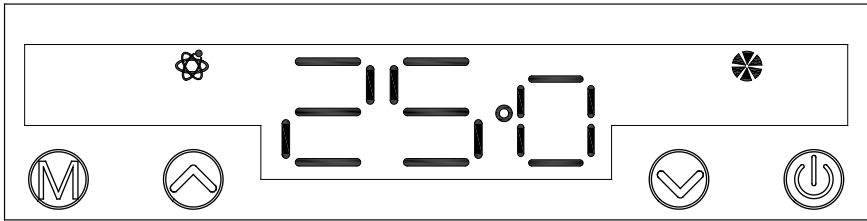

Intelligent heating mode

The heat pump automatically switches to economy mode, standard mode and high demand mode according to different ambient temperatures.

When ambient temp reaches $T01 > R10$, the heat pump will enter Eco heating mode. (electric heater can not start up)

When ambient temp reaches $R09 < T01 \leq R10$, the heat pump will enter standard heating mode. (after R06 time , electric heater will judge whether to start up according to R03 return differential temp)

When ambient temp reaches $R08 < T01 \leq R09$, the heat pump will enter high demand heating mode. (electric heater will judge whether to start up according to R03 return differential temp)



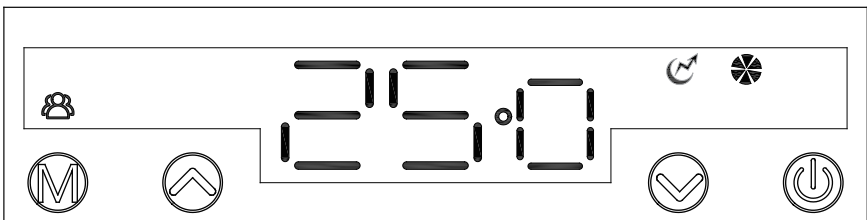



Press the “M”



High demand heating mode.

We also call it high demand heating mode. The difference between heating mode and high requirement mode is R06 delay time of electric heater start. In the high demand heating mode, electric heater will start without delay, which can help user to heat water quickly in a short time.

9.2.3 Target temperature checking and setting

In the standby or running interface, press “” or “” once to check the target temperature of the outlet water. Press “” or “” again to change the target temperature. After making the changes to the parameter, press “” to confirm or “” to cancel the changes, then return to the previous interface. If no operations are performed on the keypad for 5s, the controller exits the parameter modification menu by timeout and the changes are confirmed.

Example: Change the target temperature from 50°C to 55°C when the actual outlet water temperature is 25°C.

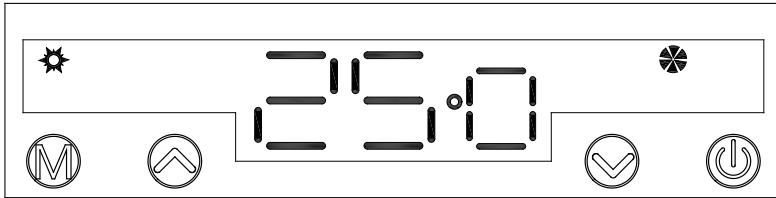

Press the "" or "" to check the target temperature.

Flashing

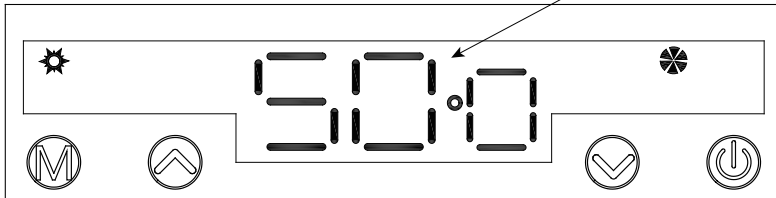

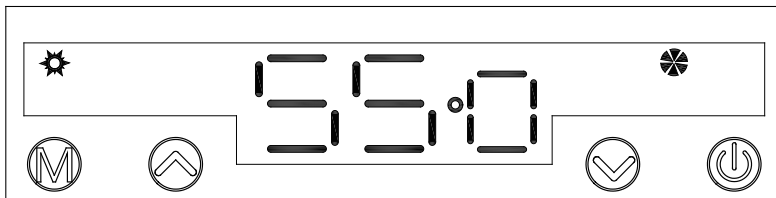

Press "" again to change the target temperature.

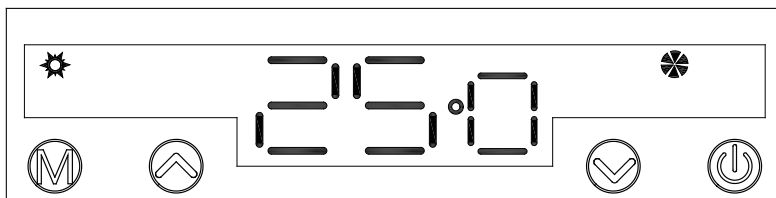

Press "" to confirm or "" to cancel, then return to the previous interface.



9.2.4 Electric heating mode

When the unit is off, press the “” for 2 seconds to manually initiate the electric heating mode, all other modes’ icons are off, main screen displays “OFF” and tank’s upper temperature at 2 seconds intervals in turn. If the electric heater is turned on, the icon of “” goes on ; and the icon goes off once the electric heater is off. You can power off the electric heating mode by pressing the “” for 2 seconds again, and the main screen displays “OFF”.
Example:

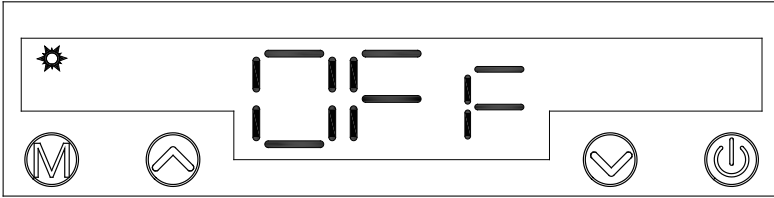

Press the “” for 2 seconds.

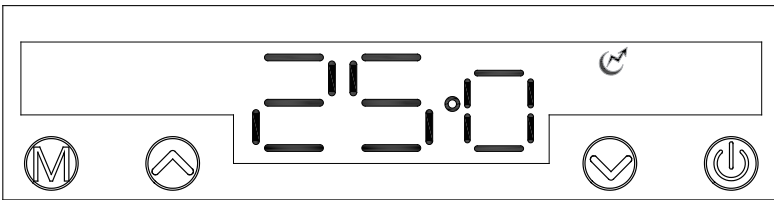

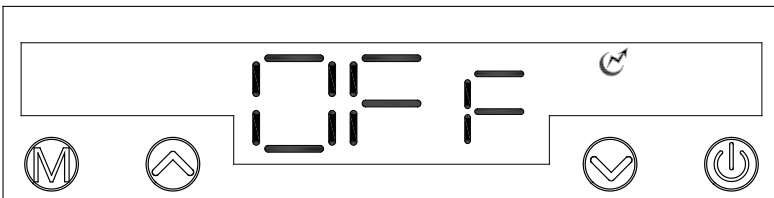

2 seconds later.

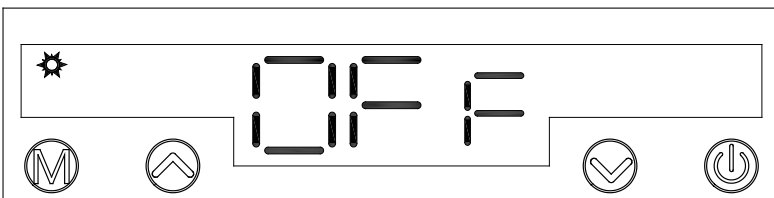

Press the “” for 2 seconds.



9.2.5 Tank's bottom temperature display

When the unit is on, you can press the “” for 2 seconds, so the screen will display the tank's bottom temperature for 10 seconds. Then it will restore displaying the tank's upper temperature after 10 seconds of no further action or press the “” during this period.

Example:

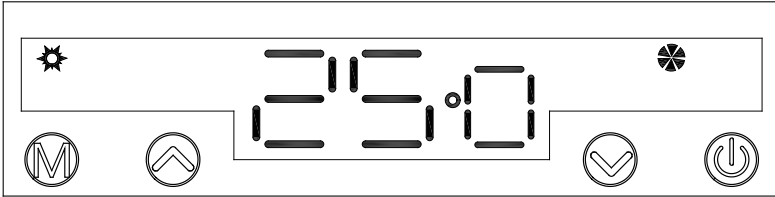

Press the “” for 2 seconds.

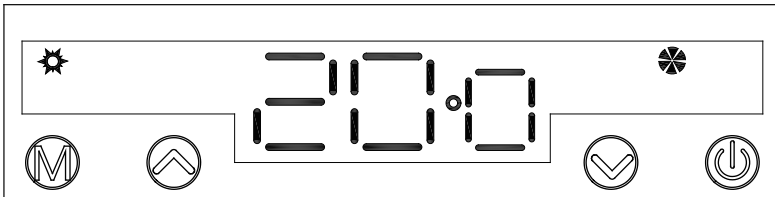

After 10 seconds of no further action or press the “” during this period.

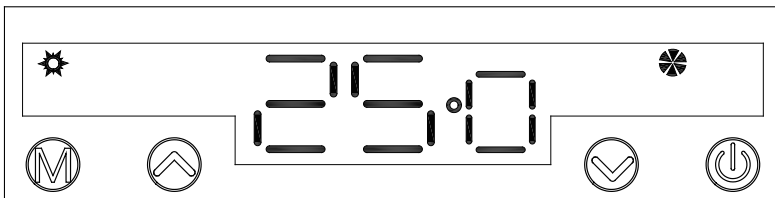

9.2.6 Ventilation function

When the unit is off, you can press the “M” for 5 seconds to enter ventilation function, and its icon starts flashing. You can press the “M” for 5 seconds again to cancel the function, then its icon stops flashing.

Example:

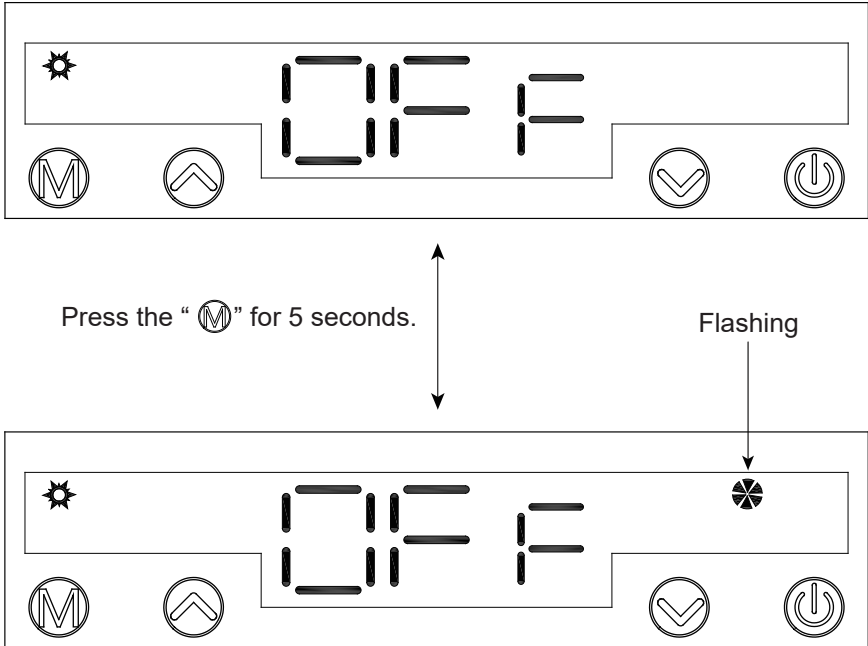

9.2.7 Keyboard locking

Press “⏻” and hold for 5 seconds once to lock the keyboard. Press “⏻” and hold for 5 seconds again to unlock the keyboard.

Example:

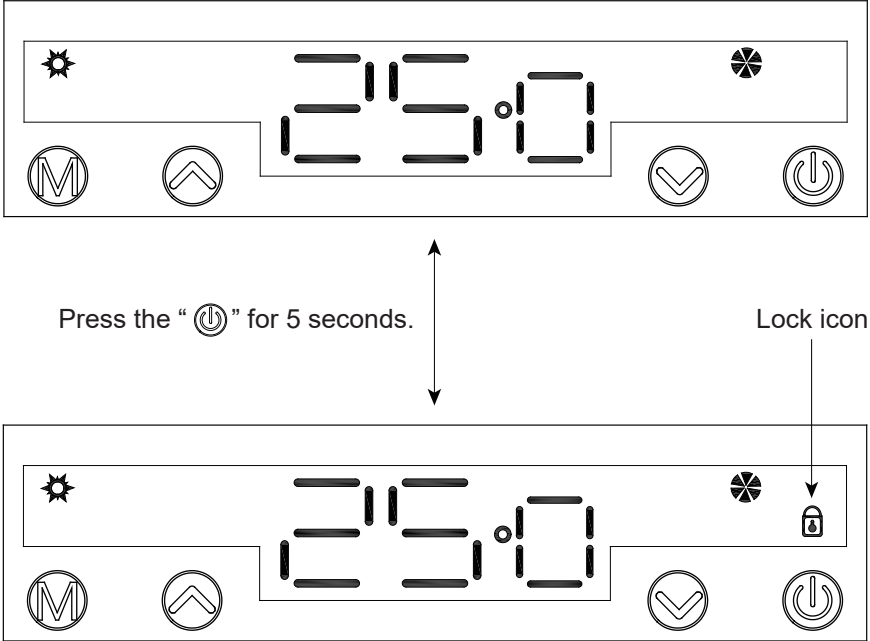

10. Failure List & Troubleshooting

10.1. Non-error tips

1) Why the compressor is not running when I start up the unit?

Answer: When the unit is powered on after the last shut-down, the compressor will not run until 3 minutes later. This is the self-protection of the unit.

2) Why sometimes the outlet water temperature on the display increases slowly?

Answer: Because the water temperature is different between the upper layer and bottom layer in the tank at the beginning. When the water temperature in all parts of the tank is basically the same, it will rise faster.

3) Why the outlet water temperature on the display decreases when the unit is in heating mode?

Answer: If the upper water temperature is much higher than that of the bottom water, the water temperature will decrease a little because of the convection between hot water and cold water in the tank.

4) Why does the unit not start up to heat when the outlet water temperature decreases?

Answer: The water temperature will decrease because of the heat loss if the hot water in the tank is not used for a long time. In order to avoid the continual ON/OFF, the unit does not start up until the water temperature decrease for more than 5°C.

5) Why does the outlet water temperature decrease a lot abruptly?

Answer: The temperatures of hot water and cold water in the tank are different. The cold water may go to the upper sensor when the hot water have been used up.

6) Why the hot water is still available when the water out temperature on the display decreases a lot?

Answer: Because the upper sensor is positioned near the top of the tank, there is still 1/5 of hot water available when the outlet water temperature on the display decreases a lot.

7) Why the compressor stops but the fan keeps running when the unit is in the heating mode?

Answer: The unit needs to defrost when the evaporator freezes because of the low ambient temperature. The compressor will stop and the fan keeps running when the unit defrosts.

8) Why is the heating time so long?

Answer: Energy saving, little power consumption and long heating time are the

distinguishing features of the units. Normally, the heating time is 2~6 hours according to the inlet water temperature, water consumption and ambient temperature.

10.2. The normal failure and solutions

For any malfunctions, please refer to the table below:

Display	Malfunction Description	Corrective action
P01	Bottom water temp. Failure (The water bottom temp. Sensor is open or short circuit)	Check or change the water bottom temp. Sensor
P02	Top tank water temp. Failure (The water top tank temp. sensor is open or short circuit)	Check or change the water top tank temp. Sensor
P04	Ambient temp. Failure (The ambient temp. sensor is open or short circuit)	Check or change the ambient temp. Sensor
P05	Coil temp. Failure (The pipe temp. sensor is open or short circuit)	Check or change the pipe temp. Sensor
P07	Refrigerant absorb temp. Failure (The evaporator temp. Sensor is open or short circuit)	Check or change the evaporator temp. Sensor
P09	Anti-freeze temp. Failure (The anti-freeze temp. Sensor is open or short circuit)	Check or change the anti-freeze temp. Sensor
P034	Solar temp. Failure (The solar temp. Sensor is open or short circuit)	Check or change the solar temp. Sensor
P81	Discharge temp. sensor failure (sensor is open or short circuit)	Check or change the discharge temp. senso
E01	High pressure protection (The exhaust pressure is high, high pressure switch action)	Check high pressure switch and cooling return circuit
E02	Low pressure protection (The suction pressure is low, Low pressure switch action)	Check low pressure switch and cooling return circuit
E03	Water flow failure (No water or litter water in water system)	Check the flow volume, water pump is failure or not
E04	Discharge overheating protection	Check if the refrigerant system has leak points or is blocked.
E07	Anti-freeze protection (Water flow volume not enough, Water system pressure difference is small)	Check the flow volume, water system is jammed or not
E08	Communication failure (Wired remote control with master signal failure)	Check the connection line between the wired remote control and motherboard

E09	Winter frost protection(Ambient temperature is too low)	
E10	Discharge overheating three times protection	Check if the refrigerant system has leak points or is blocked.



Code:20220304-0003