

# OPERATING MANUAL

## HF Radial Roof Fans

### Series

HF D ... – 13/16 D

and

HF D ... – 15/17 D



These operating instructions are valid for the standard and ATEX versions

Edition 06/14



---

*These operating instruction are part of the fan and must be available to the operating personnel at all times. The safety information given in these instructions must be followed. In the event of a fan resale, these operating instructions must be included with the equipment supplied.*

---

#### **Translation**

In the event of supply or subsequent sale into the countries of the EEA, the operating instructions must be translated into the language of the user country accordingly.

If the translated text contains divergences, always refer to the wording of the original (German) operating instructions, or contact the manufacturer.

#### **Copyright**

Unless explicitly authorized, distribution and reproduction of this document, utilization and notification of its content are not permitted. Violations will cause indemnities. All rights reserved.

## 1 Contents

### 1.1 Table of contents

<b>1 Contents</b>	<b>3</b>
1.1 Table of contents	3
1.2 Declarations of conformity	4
<b>2 Construction and correct use for the intended application</b>	<b>5</b>
2.1 Construction of the fan	5
2.2 Correct use for the intended application and field of application	6
<b>3 Product-specific data</b>	<b>8</b>
3.1 General data	10
3.2 Power supply (see motor type label)	10
<b>4 Safety</b>	<b>11</b>
4.1 Signs and explanations	11
4.2 Fan marking	12
4.3 Built-in safety systems (to be implemented by the user)	13
4.4 Interfaces of the fan	14
4.5 Safety measures (to be implemented by the user)	14
4.6 User's responsibilities	14
<b>5 General warning symbols</b>	<b>15</b>
5.1 Hazards	15
5.2 Operating and hazardous areas on the fan	15
5.3 Installation of spare and wear parts	16
<b>6 Installation</b>	<b>16</b>
6.1 Scope of supplies	16
6.2 Transport and packing	16
6.3 Delivery (also with spare and substitute parts)	17
6.4 Intermediate storage	17
6.5 Transport to the place of installation (at the customer's site)	18
6.6 Installation, mounting, Initial commissioning	19
6.7 Operating modes	20
<b>7 Operation</b>	<b>20</b>
<b>8 Maintenance / Cleaning</b>	<b>20</b>
8.1 Cleaning	22
8.2 Inspection interval/function checking	23
8.3 General hints for maintenance	23
8.4 Checks	23
<b>9 Troubles, causes and measures</b>	<b>24</b>
<b>10 Emergency</b>	<b>25</b>
<b>11 Dismantling / disposal</b>	<b>25</b>

## 1.2 Declarations of conformity

for the purpose of

- **Machine Directive 2006/42/EC, Annex II A for Machines.**
- **Low Voltage Directive 2006/95/EC, Annex III**
- **EMC Directive 2004/108/EC, Annex I and II**

We hereby declare that the construction type of the supplied version of

**Denomination: HF Roof radial fans Type: HF D ... - 13/16 D and HF D ... - 15/17 D Series**

complies with the above regulations.

Directive /Standard	Title
<b>2006/42/EC</b>	<b>EC Directive: Machines</b>
DIN EN ISO 12100:2011	Safety of machinery - General principles for design – Risk assessment and risk reduction
<b>Reference to the following standards is made additionally in the EN 12100:</b>	
DIN EN ISO 13857:2008, DIN EN 349:1993, DIN EN 953:2009, DIN EN ISO13732-1:2006	
prEN 14461:2002	Industrial fans - Safety requirements
DIN EN 62079:2001	Preparation of instructions - Structuring, content and presentation
<b>2004/108/EC</b>	<b>EC Directive: On the Electromagnetic Compatibility</b>
DIN EN 61000-6-4:2007	Electromagnetic compatibility, Generic standards; Emission standard for industrial environments
DIN EN 61000-6-2:2005	Electromagnetic compatibility, Generic standards - Immunity for industrial environments

If the fan is modified without prior agreement with Hürner-Funken, this declaration is void.

Name and address of the person, who is authorized, to assent the technical documents: Margarete Loth, Hürner-Funken GmbH, Ernst-Hürner-Straße, 35325 Mücke-Atzenhain, Germany

Mücke-Atzenhain, den 01. August 2011



Dr. Mauch, Technical Director

**Declaration of conformity (if a corresponding marking as shown in Chapter 4.2, on the right side of page 12, is provided.)**

for the purpose of

- **Directive 94/9/EC (ATEX) concerning equipment and protective systems intended for use in potentially explosive atmospheres**

We hereby declare that the construction type of the supplied version of

**Denomination: HF Roof radial fans Type: HF D ... - 13/16 D and HF D ... - 15/17 D Series**

complies with the above regulations and the DIN EN standards mentioned below:

Harmonized standards according to directives:

94/9/EC	EC directive: for equipment and protective systems intended for use in potentially explosive atmospheres
DIN EN 1127-1:2008	Explosion prevention and protection — Part 1: Basic concepts and methodology
DIN EN 13237:2003	Terms and definitions for equipment and protective systems intended for use in potentially explosive atmospheres
DIN EN 13463-1:2009	Part 1: Basic method and requirements
DIN EN 13463-5:2003	Part 5: Protection by constructional safety "c"
DIN EN 14986:2007	Design of fans working in potentially explosive atmospheres
DIN EN 15198:2007	Methodology for the risk assessment of non-electrical equipment and components for intended use in potentially explosive atmospheres

If the fan is modified without prior agreement with Hürner-Funken, this declaration is void.

Name and address of the person, who is authorized, to assent the technical documents: Margarete Loth, Hürner-Funken GmbH, Ernst-Hürner-Straße, 35325 Mücke-Atzenhain, Germany

Mücke-Atzenhain, den 01. August 2011



Dr. Mauch, Technical Director

## 2 Construction and correct use for the intended application

### 2.1 Construction of the fan

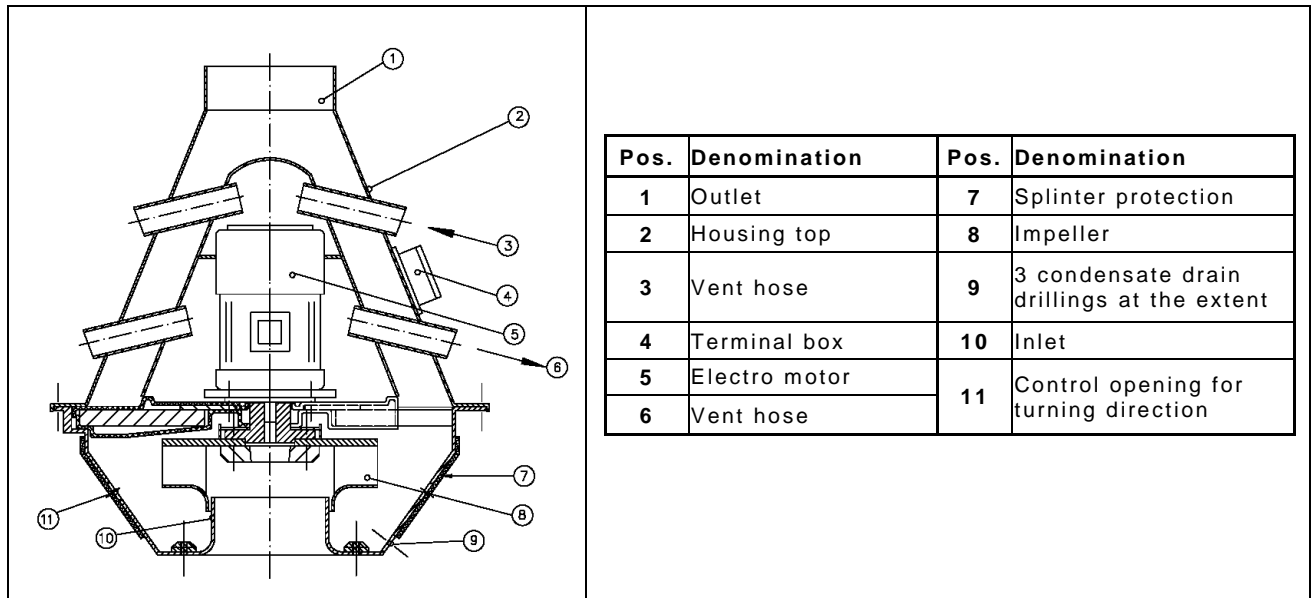

Fig.1 Overview of the fan HF D ...-13/16 D

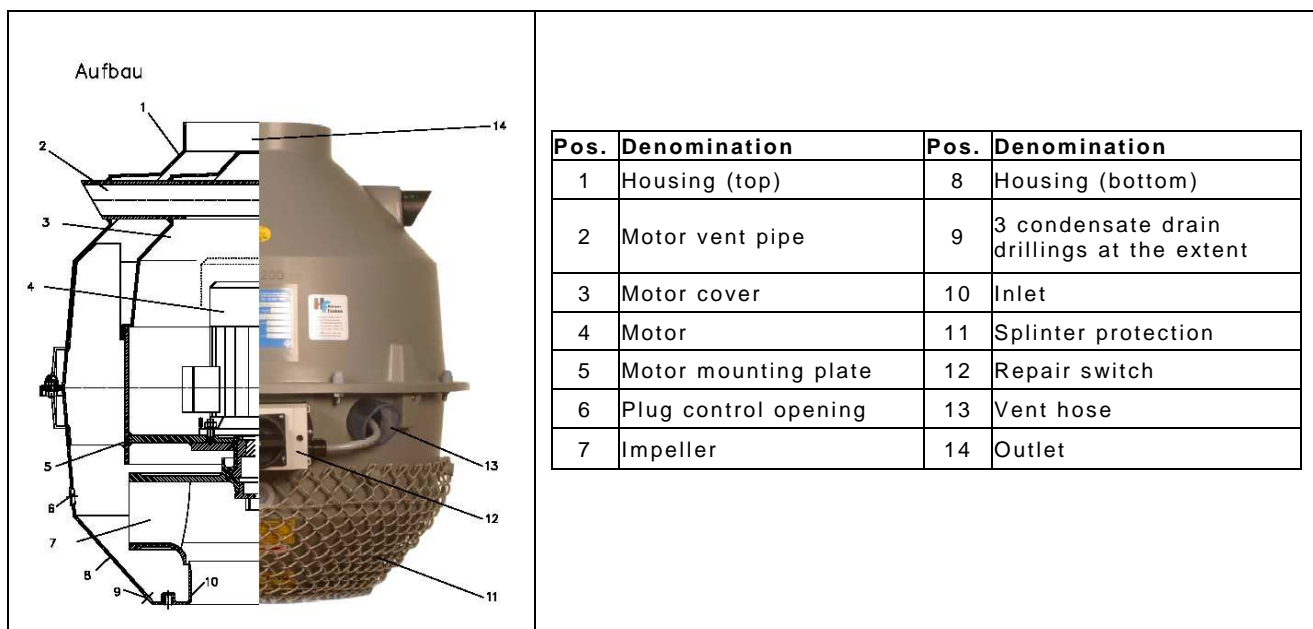

Fig.2 Overview of the fan HF D ...-15/17 D

HF roof radial fans consist of the following main assemblies: Housing, impeller and drive motor.

They are only built with direct drive (impeller on the motor shaft).

The housing of the fan series HF D ...-13D/16D is deep drawn and the impeller is made of PPs/PP-FR as standard. On request, the housings are made of polypropylene (PP, PPs/PP-FR), polyethylene (PE), polyvinyl chloride (PVC) and other thermoplastics.

The housings of the fan series HF D ...-15D/17D are made of flame retardant polyethylene (PEs/PE-FR) by centrifugal moulding, the impeller is injection-moulded of flame-retardant polypropylene (PPs/PP-FR). The housing is performed with a splinter protection, has on its deepest point (lateral) condensate drain drillings and it can be delivered with revision opening if requested.

The impeller is statically and dynamically balanced (min. quality class Q 6.3 acc. to DIN ISO 1940).

Main differentiating factor of the impellers of these series are the different bladings. The maximum impeller r.p.m.s correspond to the maximum values specified in the characteristic curve diagrams. For increasing the impeller r.p.m., previous consultation of the manufacturer is indispensable.

Fans for installation inside the explosion-hazarded area are equipped with a protective grid on the inlet and outlet side. If the grid is not provided, it must be installed by the user.

For fans which are appropriated for the use in Ex-zone 1 the housing and the impeller are made of electrical conductive thermoplastics. The standard thermoplastic plastic fan is not equipped with shaft sealing. The exhaust fluid is aspirated axially by the rotating impeller and transported radially to the outlet in the helicoidal housing. The applied energy is converted into mass flow and pressure increase of the exhaust fluid in the impeller.

## 2.2 Correct use for the intended application and field of application

HF fans are suitable for exhausting aggressive, dust-free, low-aerosol gases and clean air. Explosive atmosphere can be exhausted only using HF fans designed specially for this application. The permissible gas temperatures for the most frequently used plastics materials are generally:

with PVC: 0 °C to 50 °C,

**with PE, PE-FR (PEs) -20 °C to 60 °C,**

**with PP , PP-FR (PPs): 0 °C to 70 °C,**

and with PVDF: -10 °C to 100 °C,

These temperatures must not be exceeded.

Depending on gas composition and impeller speed, these temperature ranges must be check and restricted, if necessary. With particularly aggressive media, the reductions must be checked and determined individually in each case.

The max. ambient temperature is 40°C.

The fan was developed, designed and built exclusively for industrial and commercial use. Using the fan for domestic purposes is excluded.





**Installation inside the explosion-hazarded area:**

Installation inside the explosion-hazarded area is not permissible, unless the fan is provided explicitly for this purpose (see type label Chapter 4.2, page 12).



**Repair and maintenance** works of explosion-proof fans may **only** be performed **by qualified persons in the explosion protection** by using **original spare parts**.

If the fan has an open inlet and / or outlet (Type A, B, C according to ISO 13349), the fan must have the same category inside and outside.

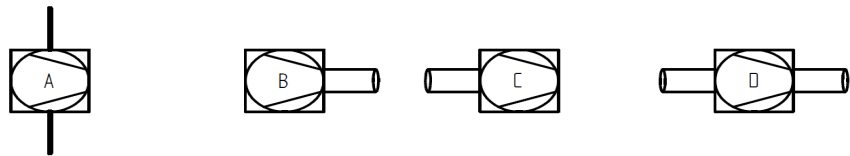

**Types of connection**



**Residual risks**

Although the fans have been constructed according to the newest technology as well as to the security rules and they are monitored by quality assurance (QA) system, there remains a residual risk due to the possible rupture of the impeller. This happens especially, when the conditions of use have not been complied. Therefore it is necessary to pay attention on technically perfect conditions and on the right case of application. The environment of the fans has to be secured in such a way, that in case of a damage, neither persons nor objects get harmed.



These assemblies are intended exclusively for the above purpose. Using the assemblies for different purposes than described above, or modifying them without written consent of the manufacturer are considered as non-compliant with the intended application. The manufacturer cannot be held responsible for damage resulting from such use. The risk is borne exclusively by the user. The fan may be started only after checking that all safety devices are operable and that the system in which this fan is installed complies with the EU directives.

The correct use for the intended application also implies compliance with the instructions given in the manufacturer operating manual and with the conditions for maintenance and repair.

The HF plastic fans are not covered by the "Regulation No 327/2011 of the European Commission about the implementation of Directive 2009/125/EC (ErP Directive)" because they are intended for the extraction of highly corrosive media.

### 3 Product-specific data



*The materials/fluids for the correct use of the fan in compliance with the intended application are procured and applied by the manufacturer. The user is responsible exclusively for correct handling of these materials/fluids and the related hazards. Information on hazards and disposal must be provided by the user. Follow the rules given in the manufacturer's safety data sheets for materials and fluids.*

#### Technical data sheet HF D ...-13/16 D

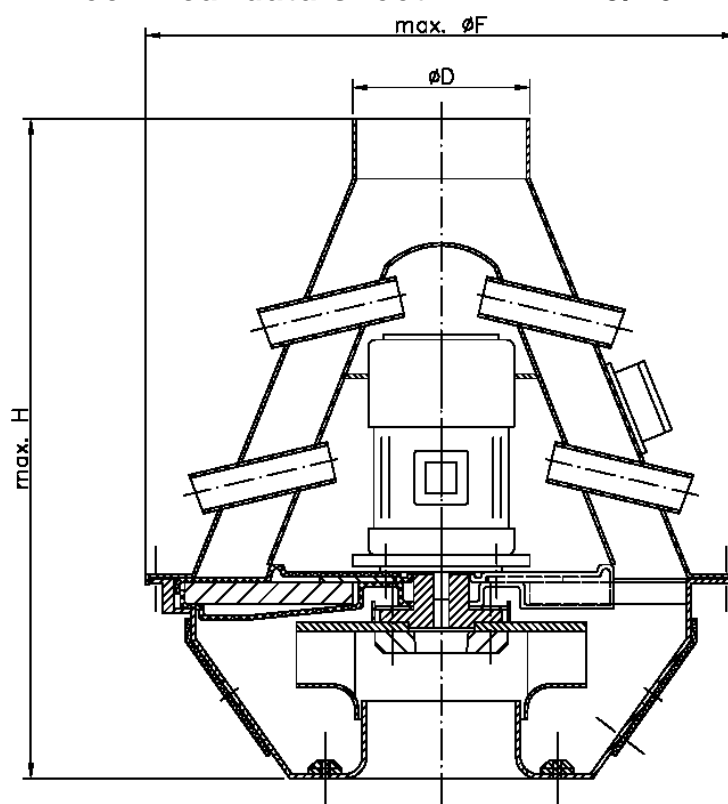

Type	ØD	ØF	H	max. weight (kg)
HF D 160-16 D	160	535	600	29
HF D 200-16 D	200	535	600	35
HF D 250-16 D	250	650	635	38
HF D 315-16 D	315	790	930	66
HF D 355-16 D	355	890	1023	84
HF D 400-16 D	400	1000	1138	148
HF D 500-13 D	500	1080	1185	131
HF D 560-13 D	560	1190	1320	177
HF D 630-13 D	630	1340	1475	257
HF D 800-13 D	800	1660	1871	498
HF D 1000-13 D	1000	2060	2265	933

Dimensions and design can be changed

Dimensions in mm



Technical data sheet HF D ...-15/17 D

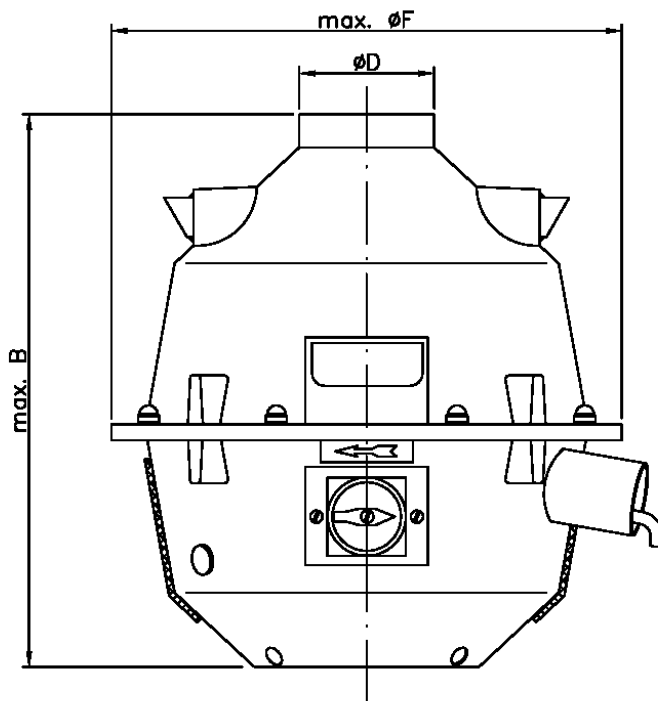

Type	Ø D	max. B	max. F	max. kg
HF D 110-17	110	451	416	7,5
HF D 160-17	160	554	501	17
HF D 200-17	200	632	578	23
HF D 250-15	250	612	626	40
HF D 250-17	250	720	714	42
HF D 315-15	315	737	815	48

Dimensions and design can be changed Dimensions in mm

### 3.1 General data

#### Ambient temperature range

The specifications on the type label are applicable. If they are missing, the temperature range is – 20°C to + 40°C.

#### Noise level

For the value applicable to each fan, see the manufacturer internet site, or contact us via phone.

More relevant data are given on the type label.

### 3.2 Power supply (see motor type label)

Optionally, the electric motors can be controlled continuously by means of a frequency inverter. The maximal rotation speed at the impeller (see fan type label) must not be exceeded.

In case of operation of several motors with a frequency inverter all-pole sinusoidal filters should be used between frequency inverter and motor. If frequency inverters are used in the explosion-hazarded area (Zone 1) these must be installed outside the explosion-hazarded area and flameproof motors to DIN EN 60079-1 must be used.



---

*Before connecting the fan, check the specifications on the type label and dimension the electrical control system accordingly.*

*With a motor power  $\geq 7,5$  kW for starting up the fan is a star-delta-connection, a soft starter or a FI regulation to use to protect the impeller and the motor bearing against premature damages.*

*In the case of direct involvement or frequent restart, damage or increased wear may arise by the torque forces on the impeller.*

---

## 4 Safety

### 4.1 Signs and explanations



*The information given in the operating manual is binding is marked with a "book".*



*Warnings are marked with a "STOP" sign.*



*Danger warnings are marked with a warning triangle.*



*Notes are marked with a hand symbol.*



*Hazards due to electric current are marked with the symbol shown opposite.*



*Protective earth connection is marked by this symbol at the connecting points.*



*Hazards due to explosive atmosphere are marked with the symbol shown opposite.*

## 4.2 Fan marking

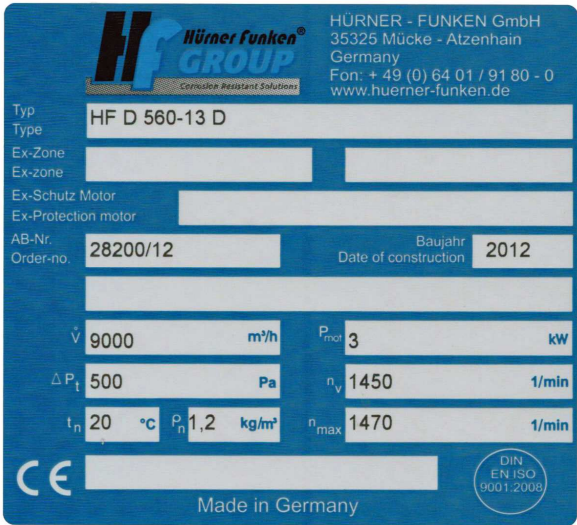
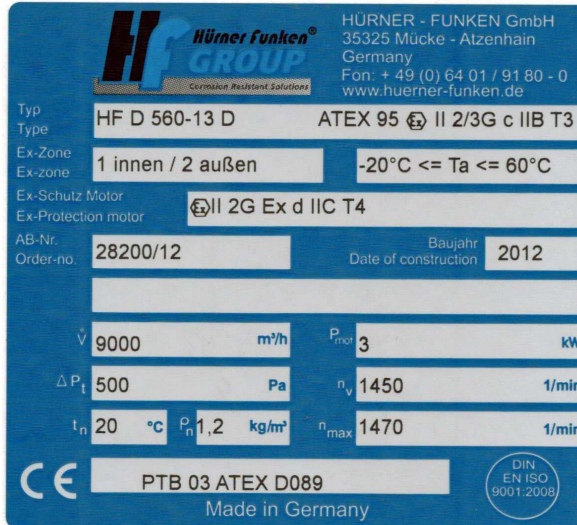
Example	Example
 <p>Typ Type: HF D 560-13 D</p> <p>Ex-Zone Ex-zone:</p> <p>Ex-Schutz Motor Ex-Protection motor:</p> <p>AB-Nr. Order-no.: 28200/12</p> <p>Baujahr Date of construction: 2012</p> <p><math>\dot{V}</math> 9000 m<sup>3</sup>/h <math>P_{motor}</math> 3 kW</p> <p><math>\Delta P_t</math> 500 Pa <math>n_v</math> 1450 1/min</p> <p><math>t_n</math> 20 °C <math>P_n</math> 1,2 kg/m<sup>3</sup> <math>n_{max}</math> 1470 1/min</p> <p>CE Made in Germany DIN EN ISO 9001:2008</p>	 <p>Typ Type: HF D 560-13 D ATEX 95 Ex II 2/3G c IIB T3</p> <p>Ex-Zone Ex-zone: 1 innen / 2 außen -20°C ≤ Ta ≤ 60°C</p> <p>Ex-Schutz Motor Ex-Protection motor: Ex II 2G Ex d IIC T4</p> <p>AB-Nr. Order-no.: 28200/12</p> <p>Baujahr Date of construction: 2012</p> <p><math>\dot{V}</math> 9000 m<sup>3</sup>/h <math>P_{motor}</math> 3 kW</p> <p><math>\Delta P_t</math> 500 Pa <math>n_v</math> 1450 1/min</p> <p><math>t_n</math> 20 °C <math>P_n</math> 1,2 kg/m<sup>3</sup> <math>n_{max}</math> 1470 1/min</p> <p>CE PTB 03 ATEX D089 Made in Germany DIN EN ISO 9001:2008</p>
<p>Specifications on the label for fans <u>without</u> explosion protection:</p> <p>Type: Order confirmation no. (AB) year of construction Fan-specific data</p>	<p>Specifications given on the label for fans <u>with</u> explosion protection:</p> <p>Type Denomination of explosion protection type Zone internal/external temperature Motor explosion protection type Order confirmation no. year of construction Fan-specific data</p>

**Fig.2** Type label (normal application)

**Fig.3** Type label (explosive atmosphere)



*Caution: Fans without explosion protection marking are not permissible for operation inside the explosion-hazarded atmosphere. This applies to the environment and the exhausted fluid.*

### Meaning of possible device categories on the type label:

**II 2G** The fan is suitable for exhaustion from Zone 1 and for installation in Zone 1

**II 2/3G** The fan is suitable for exhaustion from Zone 1 and for installation in Zone 2

**II 3G** The fan is suitable for exhaustion from Zone 2 and for installation in Zone 2

**II 3/-G** The fan is suitable for exhaustion from Zone 2 and must be installed outside the hazardous area.

The information given in these operating instructions is only applicable to the fan type specified on the title page. The type label with the type denomination is located on the base frame or on the side panel of the fan housing. With all enquiries, make sure to specify the order confirmation no. and the type label properly to ensure correct and quick handling.

### 4.3 Built-in safety systems (to be implemented by the user)

The built-in safety devices must be checked at regular intervals (**d** = daily, **w** = weekly, **m** = monthly, **y** = yearly).

The following methods must be used for checking:

**V** = visual check, **F** = functional check, **M** = measurement.

#### Overcurrent protection device

To prevent overheating (fire hazard) in the event of overload (e.g. due to clogging), the fan drive has to be provided with an overcurrent protection device.

Check	
Interval	Method
<b>y</b>	<b>F</b>

#### Thermal contact (optional)

For temperature monitoring, the fan is equipped with a thermal contact. In the event of a temperature increase, the motor switches off.

Check	
Interval	Method
<b>y</b>	<b>F</b>

#### PTC resistor (optional)

Don't connect the PTC resistor to the mains voltage. Avoid exceeding a max. PTC resistor test voltage of 2.5 V.

Check	
Interval	Method
<b>y</b>	<b>F</b>

#### Protective claddings

All mobile fan components driven by the electric motor as well as all other hazardous parts of the fan are covered by fixed, safely fastened protective claddings that can be removed only using tools.

Check	
Interval	Method
<b>m</b>	<b>V</b>

#### Electrical connection

The electrical connections are made using a 4-wire supply cable system, 3 phases and 1 earth conductor with three-phase motors and using a 3-wire supply cable system, 1 phase, 1 neutral wire and 1 earth conductor with alternating current motors.

Check	
Interval	Method
<b>y</b>	<b>V, F, M</b>



---

*Deactivating the safety devices, or changing their operating principle, is strictly prohibited. .*

---

#### 4.4 Interfaces of the fan

The fan has the following interfaces:

- Pressure pipe (connection with flange)
- Terminal box and maintenance switch (electric supply)
- Pipe on suction side (connection with flange)

#### 4.5 Safety measures (to be implemented by the user)

We point out that the user is under the duty to:

- instruct the operating and maintenance personnel on the **protective devices** of the fan,
- and to ensure supervision concerning compliance with the safety measures.

This operating manual must be kept for future use. The specified frequency of inspection and control measures must be met.

- The chapters related to transport, installation and mounting, maintenance, troubles/causes/troubleshooting must be understood by a **qualified person**. Work described in this chapter may be performed only by qualified personnel.

#### 4.6 User's responsibilities



---

*In the European Economic Area, compliance with Council Directive (89/391/EEC) and the related individual directives, especially Council Directive 89/655/EEC Concerning the Minimum Safety and Health Requirements for the Use of Work Equipment by Workers at Work in the relevant national version is mandatory.*

---

The user must obtain the local **operating licence** and follow the relevant rules.

Additionally, the user must ensure compliance with the national legal regulations concerning

- the personnel safety (regulations relating to accident prevention)
- the safety of work equipment (protective equipment and maintenance)
- product recycling (Waste Management Law)
- material disposal (Waste Management Law)
- cleaning (cleaning agents and disposal)
- and comply with the requirements for environment protection.



---

*To avoid the occurrence of ignition sources, the operating and maintenance personnel must be equipped properly and receive adequate instructions for realization of cleaning and maintenance work, e.g.*

- to avoid the use of tools giving rise to sparking,
  - strict observance of the smoking ban,
  - to avoid the actuation of ignition sources (e.g. lighters, etc.).
-



## 5 General warning symbols

### 5.1 Hazards

Pay attention to the safety devices described in this manual and follow the safety notes.



During setup, maintenance and repair work, mind the **squeezing hazards**.



During setup, maintenance and repair work, mind the **hazard due to electric current!**



During setup, maintenance and repair work, be aware of the **risk of getting burned** due to hot components.  
In the event of a failure of the forced ventilation, the drive motor presents a hazard of **getting burned**.



When doing setup, maintenance and repair work within the explosion-hazarded area, make sure that there isn't a critical gas concentration. Use a gas detector. Always avoid handling all kinds of ignition sources inside the explosion-hazarded area. Welding, cutting and polishing work may be performed only, if the related permission was granted.

### 5.2 Operating and hazardous areas on the fan

#### Hazardous area

During setup, maintenance and repair work, the overall area around the fan is a hazardous area.



During maintenance and repair work, the hazardous area extends 1 m around the fan. The flap pivoting area must be taken into account as well. Keep the area around the fan free from any objects.

### 5.3 Installation of spare and wear parts

We point out explicitly that spare parts and accessories not supplied by us are not checked and released for use by us either. Installation and/or use of these products can change the design properties of your fan negatively. The manufacturer cannot be held responsible for damage resulting from the use of other than original components. In connection with the order confirmation, you will receive a data card and a spare parts list for the fan.

If you need spare parts, please, inform our sales partner:

#### **Hürner-Funken GmbH**

Ernst-Hürner-Straße  
35325 Mücke-Atzenhain  
Germany

Fon: +49 (0) 6401 / 9180 – 0  
Fax: +49 (0) 6401 / 9180 – 142  
e-Mail: [info@huerner-funken.de](mailto:info@huerner-funken.de)  
http: <http://www.huerner-funken.de>

#### **For Asia:**

#### **Hürner Funken Malaysia Sdn. Bhd.**

Lot 3, Milon Industrial Park  
Jalan Minlon Utama off Jalan Taming 2  
Taming Jaya, 43300 Balakong  
Selangor DE  
Malaysia

Fon: +603 8961 9863  
Fax: +603 8961 9862

http: [www.huerner-funken.com.my](http://www.huerner-funken.com.my)

#### **When ordering spare parts, please specify the following data:**

- Order no. (see type label)
- Fan type
- Spare part denomination

## 6 Installation

### 6.1 Scope of supplies

#### **The equipment delivered to the user comprises:**

- 1 HF roof radial fan
- 2 Operating instructions
- 3 Technical documents

For the detailed scope of equipment supplied, refer to the order confirmation.

### 6.2 Transport and packing

Although HF - fans are checked and packed carefully before shipment, damage during transport cannot be excluded.

### 6.3 Delivery (also with spare and substitute parts)

#### Inspection of incoming components:

- Check, if the consignment is complete according to the bill of delivery.

#### In the event of damage

- Check the consignment for damage (visual inspection).

#### In the event of complaints

If the consignment was damaged during transport:

- Contact the last forwarder immediately.
- Keep the packaging (for checking by the forwarder or for returning the product).

#### Packaging for returning the product

- If possible, use the original packaging and the original packaging material. If the original packaging and packaging material haven't been kept, use commercial packaging material.  
Fasten the fan to a transport pallet (it must be dimensioned appropriately for the weight).
- With any questions relating to packaging and safe transport, please, consult the manufacturer.

### 6.4 Intermediate storage

The fans should be stored in a room or under a shelter. With outdoor storage, protect the fan from dirt and atmospheric conditions using a canvas cover. Keep the storage temperature between 0°C and +40°C.

## 6.5 Transport to the place of installation (at the customer's site)



Transport must be performed only by qualified personnel in compliance with the local conditions and any warning notes on the packaging material.



The fan or fan unit is transported on transport pallets to the site.

The fan or transport unit **may tip** over during transport. Pay attention to the **focus** (the focus is centred) and **weight** (see technical data).

**Secure** the fan or the transport unit with appropriated resources before the transport.

### Transport with forklift

- The forklift has to be adjusted according to the weight of the fan or the transport unit.
- Drive with the forks of the forklift between or under the arbors of the transport pallet of the fan or the transport unit.
- Make sure that the forks of the forklift are completely under the arbor (the forks have to look out at the opposite).
- Lift the fan or transport unit and transport it.

### Transport of the fan to the site

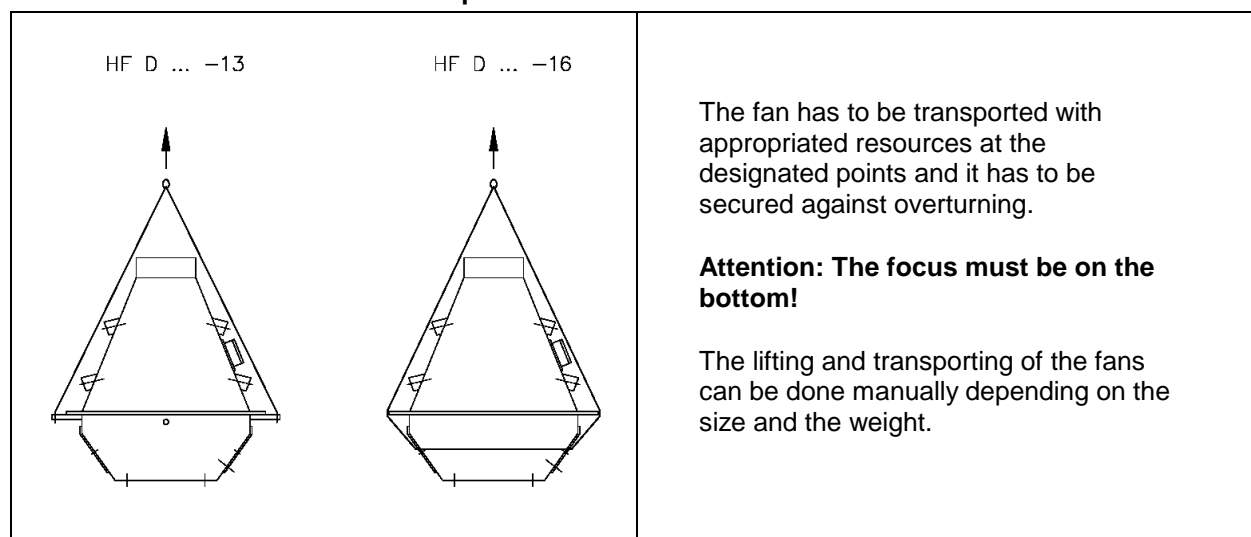

**Abb.5** Transport of the fan HF D ...-13/16 D to the site

## 6.6 Installation, mounting, Initial commissioning

Installation, mounting and initial commissioning of the fan are performed by qualified personnel of manufacturer or by qualified customer personnel that must have been trained adequately for this work.

- The constructional arrangement of the fan must ensure that operational underpressure conditions are present at the shaft passage.
- Check on the basis of the static of the building, if it is adjustable for the burden of the fan and if the bottom is flat.
- The installation of the fans and their components are based on the on-site installation plan.
- To avoid vibration, we recommend installing the fan on vibration absorbers.
- The fan must not be operated in non-installed condition. The impeller must be free to move without any impediment at all times.
- Mount the (on-site) pipe.
- The fan is equipped with a terminal box for connecting to the mains supply. The energy supply can be cut off using an onsite maintenance switch.
- Check before the first operation that the turning direction is correct (direction arrow on the fan housing) and that the max. speed is not exceeded (see nameplate).
- If there is danger of foreign parts falling into the fan or being aspirated, the connected pipe upstream and downstream of the fan must be provided with a protective grid (min. IP20 to EN 60529).
- The fans are adjusted for a surrounding temperature of max. 40°C.
- The inside of the fan and of upstream and downstream channels and units must be kept free from foreign bodies.
- See point 3.2.



---

*The fan may be connected to the supply voltage and switched on only, when the pipe (on the inlet and outlet side) has been connected completely.*

*Installation must be performed according to the connecting diagram in the motor operating instructions only by adequately trained and qualified personnel.*

---

### **The following conditions must be met:**

- Compliance with the national regulations relating to the public utilities.
- The supply voltage at the place of installation and the mains frequency must correspond to the values specified on the motor type label.
- The power supply cable must be protected against damage and dimensioned adequately for the power rating.
- Set the thermal overcurrent relay to the nominal current specified on the motor type label and follow the instructions given in the motor operating instructions. We reserve ourselves the right to cancel the motor warranty in the event of failure to comply with this protective measure.



---

Make sure that the **rotating direction** is correct. To check the rotating direction, switch on the motor shortly and compare the impeller rotating direction with the arrow marked on the housing. If the rotating direction is wrong, change the motor polarity in compliance with the safety regulations. After reaching the operating speed, measure the power consumption immediately and compare it to the motor current specified on the type label.

---



---

**24 h** after initial commissioning: Check the tightness of the housing and the quiet run of the fan and re-tighten the screws.

---



---

**Caution:** The fan pipe connections may be performed only using flexible couplings (compensators).

---

## 6.7 Operating modes

The fan is switched on and off via an on-site operating unit provided by the user, or operated via an on-site supervisory system. It is designed for continuous operation.

## 7 Operation



---

The fan may be operated only by specialized personnel qualified and trained for operation.

---

## 8 Maintenance / Cleaning



---

The **chapter on "Maintenance/cleaning"** is intended only for qualified personnel. Maintenance, cleaning and repair work may be performed only by qualified personnel.

---



#### Qualified person

- A person who is able to assess the work he/she is in charge of and aware of potential hazards due to his/her professional training, skills and experience as well as his/her knowledge of the relevant standards.

#### Definition according to EN 60204-1.

To ensure smooth operation of the fan, cleaning and maintenance of the fan at regular intervals is required.

During operation, the fan is subject to vibration susceptible of releasing screwed and clamping connections. To prevent damage, check the fan for loosened connections at regular intervals (recommended interval with single-shift operation: 3 months).



---

*For information on maintenance/cleaning of individual components purchased from other manufacturers (e.g. electric motor), refer to the corresponding manufacturer operating instructions.*

---



---

*When switching off the supply voltage because of cleaning, maintenance and repair work, measures to prevent the supply voltage from being switched on accidentally must be taken by the user (locking the main or maintenance switch using a padlock).*

---



---

*During maintenance and repair work, mind all rotating and mobile parts.*

---



---

*During maintenance and repair work, mind the **squeezing hazards**.*

---



---

*When doing maintenance and repair work, mind the **hazards due to electric current**.*

---



---

*Cleaning, maintenance and repair work may be done only at non-explosive atmosphere.  
For reasons of safety, only **tools** made of **non-sparking material** may be used when doing this work.*

---



The work intervals specified below are intended for single-shift operation (8 hours a day; 22 days a month; 12 months a year).

<b>d</b> = daily	<b>y</b> = yearly
<b>w</b> = weekly	<b>R</b> = cleaning required when opening
<b>m</b> = monthly	<b>LT</b> = lifetime
<b>½ y</b> = half-yearly	<b>MO</b> = manufacturer operating manual

## 8.1 Cleaning



Don't use any sharp objects or tools for cleaning. Only objects that are explicitly provided for this purpose are suitable.

Cleaning (Depending to the degree of contamination the cleaning intervals must be adapted)	Interval
Keep the fan and the area around the fan free from deposits on the outside regularly (e.g. dust, exhaust fluids).	<b>w</b>
Check the impeller regularly for contaminations and cakings and clean it, if necessary.	<b>½ y</b>
<b>Caution</b> Contaminations on the impeller can cause imbalance of the fan. Depending on the intensity, this can even cause the destruction of the fan.	



### Caution

When doing cleaning work, wear protective equipment in compliance with the operational regulations for occupational health and safety (e.g. protective gloves).

**Caution:** The bearings of the built-in electric motors are provided with a grease filling calculated for a service life of 10 000 – 20 000 operating hours.

## 8.2 Inspection interval/function checking

	Interval with single-shift operation					
	d	w	m	½ y	1 y	MO
Superordinate facility for connecting the supply voltage				X		
Settings of the on-site protective devices						X
Fan motor function checking						X

## 8.3 General hints for maintenance

Correct maintenance is decisive for the fan safety of operation and lifetime. Operational disorders due to insufficient or improper maintenance can cause high repair costs and long downtimes. For this reason, regular maintenance is indispensable.



*Before starting maintenance and repair work (especially when the fan must be opened), compliance with the switch-off procedures is essential.*

Checks: The inspection intervals must be shortened at strong degree of pollution, high ambient temperatures and frequent start /many load changes.	Interval
Check, if the fan is installed correctly and safely and pay attention to possible vibrations during operation. If necessary, re-tighten the screw connections.	m
Check the connections of the pipe on the inlet and outlet side for tightness.	m
Check the electric motor for correct and firm seating and functionality.	MO
Check the housing for stress cracks and quiet run. Check the impeller for deformations, wear and cakings.	y

## 8.4 Checks

### After completing work, please, check:

- the completeness of performed work,
- Unless there is reason to complain, the fan can be taken into operation.



*After checking and replacing the wear parts, please check, if all safety devices are fully operable.*

## 9 Troubles, causes and measures



The facts and information relating to "Troubles, cause and measures" described in this operating manual are formulated in a way that they are understood by persons with a professional training in the fields of

- electrics/electronics
- mechanics/maintenance.

Appropriate tools and test equipment must be made available to this personnel. Before any maintenance and repair work, the fan must be de-energized and protected against re-activation. Unless the specified measures are successful, please, contact the manufacturer.

Trouble	Possible cause	Remedial action
Unquiet run of fan (heavy vibration)	Foundation is subject to heavy vibration	Dampen the foundation/fan
	Deposits on the impeller	Clean the impeller
	Damage on impeller	Consult the manufacturer
Motor bearing noise	Motor bearing damaged	Replace bearing or motor, consult manufacturer or motor supplier
Fan power output too low	Wrong impeller rotating direction	Reverse the rotating direction
Motor power consumption to high	Output reduction facilities are not opened, or opened only partly	Check the output power reduction facilities
	Pipe resistances on inlet or outlet side too high	Reduce resistances, consult the manufacturer
	Defective motor winding	Consult the manufacturer
	Protective switch not set correctly	Set the protective switch correctly
Motor is switched off by the motor protection switch	Motor protective switch is not adjusted correctly	Adjust motor protective switch correctly
	Motor winding is defective	Consult manufacturer or motor supplier
	Impeller blocked	Check impeller
Sliding noises	Motor winding defective	Consult the manufacturer
	Impeller blocked	Check the impeller
	Foreign body between impeller and housing	Remove the foreign body
Sudden power decrease	Inlet or outlet pipe untight	Check the pipes
	Connecting collar defective	Replace the collar

## 10 Emergency

In case of emergency, switch off the main switch, or withdraw the power supply connector.

## 11 Dismantling / disposal

### Dismounting

Dismounting may be done only by qualified personnel.

Before starting dismantling work, make sure that the switch-off procedures are followed.

### Disposal

The fan is made mainly of steel and plastics (except the electrical equipment) and must be discarded in compliance with the applicable local environmental regulations.



For discarding the cleaning agents, follow the local regulations and the information given in the manufacturer safety data sheets.

Contaminated cleaning tools (brushes, clothes, etc.) must be discarded in compliance with the manufacturer specifications as well.

Depending on the fan application, the housing and the impeller must be considered as special waste and discarded accordingly.

Injection moulded or sintered housings are provided with recycling signs indicating which type of plastic material was used.