

Characterised control valve, 6-way,  
Internal thread

- Two sequences (cooling/heating) with one 90° rotary actuator
- Water-side switching or modulating control of thermal heating/cooling elements
- For closed cold and warm water systems

**Type overview**

Type	DN [ ]	Rp ["]	ps [ kPa]	kvs (Sequence I) [ m³/h]	kvs (Sequence II) [ m³/h]
R3015-P25-P25-B2	15	1/2	1600	0.25	0.25
R3015-P25-P4-B2	15	1/2	1600	0.25	0.4
R3015-P25-P63-B2	15	1/2	1600	0.25	0.63
R3015-P25-1-B2	15	1/2	1600	0.25	1
R3015-P25-1P3-B2	15	1/2	1600	0.25	1.3
R3015-P4-P25-B2	15	1/2	1600	0.4	0.25
R3015-P4-P4-B2	15	1/2	1600	0.4	0.4
R3015-P4-P63-B2	15	1/2	1600	0.4	0.63
R3015-P4-1-B2	15	1/2	1600	0.4	1
R3015-P4-1P3-B2	15	1/2	1600	0.4	1.3
R3015-P63-P25-B2	15	1/2	1600	0.63	0.25
R3015-P63-P4-B2	15	1/2	1600	0.63	0.4
R3015-P63-P63-B2	15	1/2	1600	0.63	0.63
R3015-P63-1-B2	15	1/2	1600	0.63	1
R3015-P63-1P3-B2	15	1/2	1600	0.63	1.3
R3015-1-P25-B2	15	1/2	1600	1	0.25
R3015-1-P4-B2	15	1/2	1600	1	0.4
R3015-1-P63-B2	15	1/2	1600	1	0.63
R3015-1-1-B2	15	1/2	1600	1	1
R3015-1-1P3-B2	15	1/2	1600	1	1.3
R3015-1P3-P25-B2	15	1/2	1600	1.3	0.25
R3015-1P3-P4-B2	15	1/2	1600	1.3	0.4
R3015-1P3-P63-B2	15	1/2	1600	1.3	0.63
R3015-1P3-1-B2	15	1/2	1600	1.3	1
R3015-1P3-1P3-B2	15	1/2	1600	1.3	1.3
R3020-P63-1P6-B2	20	3/4	1600	0.63	1.6
R3020-P63-2P5-B2	20	3/4	1600	0.63	2.5
R3020-1-1P6-B2	20	3/4	1600	1	1.6
R3020-1-2P5-B2	20	3/4	1600	1	2.5
R3020-1P6-P63-B2	20	3/4	1600	1.6	0.63
R3020-1P6-1-B2	20	3/4	1600	1.6	1
R3020-1P6-1P6-B2	20	3/4	1600	1.6	1.6
R3020-1P6-2P5-B2	20	3/4	1600	1.6	2.5
R3020-2P5-P63-B2	20	3/4	1600	2.5	0.63
R3020-2P5-1-B2	20	3/4	1600	2.5	1
R3020-2P5-1P6-B2	20	3/4	1600	2.5	1.6
R3020-2P5-2P5-B2	20	3/4	1600	2.5	2.5

## Technical data

<b>Functional data</b>	Media	Cold and warm water, water with glycol up to max. 50% vol.	
	Medium temperature	6...80 °C	
	Permissible pressure ps	1600 kPa	
	Differential pressure $\Delta p_{max}$	100 kPa	
	Differential pressure note	low-noise operation $\Delta p_{v100} < 50 \text{ kPa}$	
	<b>Functional data</b>	Flow characteristic	Linear
Leakage rate		Leakage rate A, air-bubble-tight (EN 12266-1)	
Pipe connectors		Internal thread according to ISO 7-1	
Angle of rotation		Sequence 1: 0...30° (Cooling recommended) Dead zone: 30...60° Sequence 2: 60...90° (Heating recommended)	
Angle of rotation note		with room controller CRK24-B1 compelling sequence 1 = cooling and sequence 2 = heating	
Installation position		Upright to horizontal (in relation to the stem)	
<b>Materials</b>	Maintenance	Maintenance-free	
		Housing	Brass body nickel-plated
		Closing element	Chrome-plated brass
		Stem	Nickel-plated brass
		Stem seal	O-ring EPDM
		Valve seat	PTFE, O-ring EPDM
		Flow rate diaphragms	rostfreier Stahl

## Safety notes

- The valve has been designed for use in stationary heating, ventilation and air-conditioning systems and is not allowed to be used outside the specified field of application, especially in aircraft or in any other airborne means of transport.
- Only authorised specialists may carry out installation. All applicable legal or institutional installation regulations must be complied during installation.
- The valve does not contain any parts that can be replaced or repaired by the user.
- The valve may not be disposed of as household refuse. All locally valid regulations and requirements must be observed.
- When determining the flow rate characteristic of controlled devices, the recognised directives must be observed.

## Product features

<b>Principle of operation</b>	The 6-way characterised control valve is adjusted by a rotary actuator. The actuator is connected by a modulating control system or a MP-Bus signal and moves the ball of the ball valve to the position dictated by the positioning signal. If the valve is adjusted in the clockwise direction (till the end stop), e.g. the cooling sequence is completely enabled; if the valve is adjusted in the counter-clockwise direction (90°), e.g. the heating sequence is completely enabled.
<b>Pressure compensation</b>	In cases of combined heating/cooling control elements, the medium remains in the control element when in the closed position (no heating or cooling). The pressure of the enclosed medium can rise or fall due to changes in medium temperature caused by the ambient temperature. The 6-way characterised control valves have an integrated pressure relief function for the purpose of compensating for such pressure changes. The pressure relief function is active in the closed position (45°) of the valve; reliable separation of Sequences 1 and 2 continues. For additional information, consult the notes for project planning for the 6-way characterised control valve.

## Accessories

	Description	Type
<b>Mechanical accessories</b>	Fastening angle, for 6-way control valves	ZR-004
	Pipe connector to ball valve DN 15 Rp 1/2"	ZR2315

## Installation notes

**Recommended installation positions** The ball valve can be installed upright to horizontal. The ball valve may not be installed in a hanging position, i.e. with the stem pointing downwards.

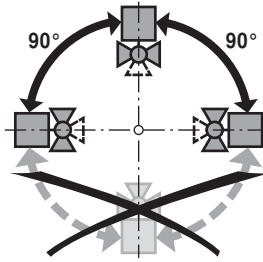

**Water quality requirements** The water quality requirements specified in VDI 2035 must be adhered to. Belimo valves are regulating devices. For the valves to function correctly in the long term, they must be kept free from particle debris (e.g. welding beads during installation work).

The installation of suitable strainer is recommended.

**Maintenance** Ball valves and rotary actuators are maintenance-free. Before any kind of service work is carried out on the actuator, it is essential to isolate the rotary actuator from the power supply (by unplugging the electrical cable). Any pumps in the part of the piping system concerned must also be switched off and the appropriate slide valves closed (allow everything to cool down first if necessary and reduce the system pressure to ambient pressure level). The system must not be returned to service until the ball valve and the rotary actuator have been properly reassembled in accordance with the instructions and the pipeline has been refilled in the proper manner.

**Flow direction** The flow direction must be observed. The position of the ball can be identified from the L-marking on the stem.

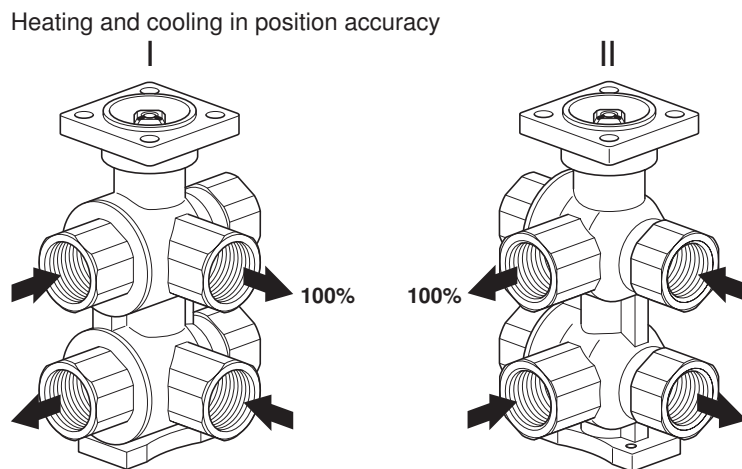

Installation notes

valve characteristic line Large globe valves, 2-way, with PN 16, DN 200 / DN 250 flange

Valve characteristic curve

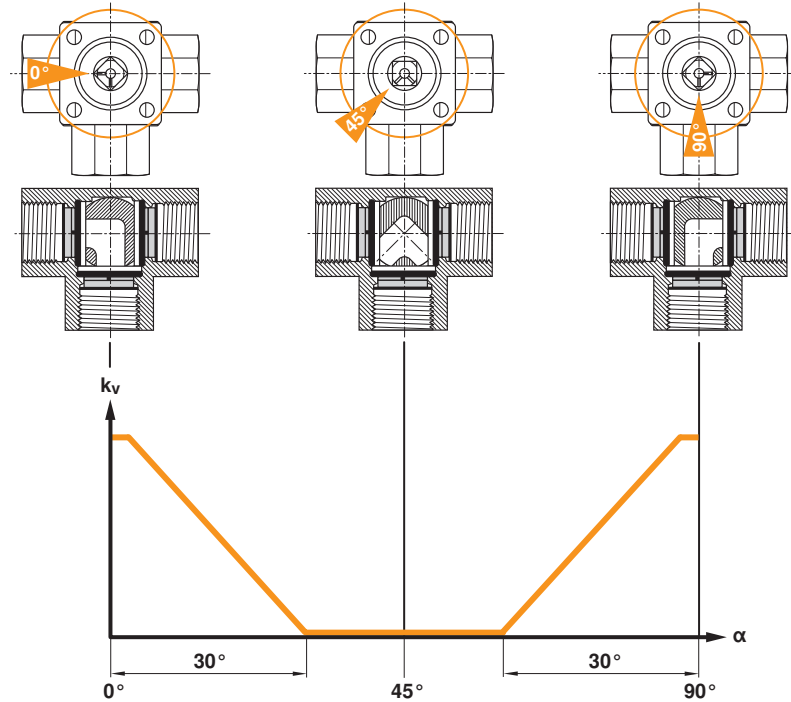

Dimensions / Weight

Dimensional drawings

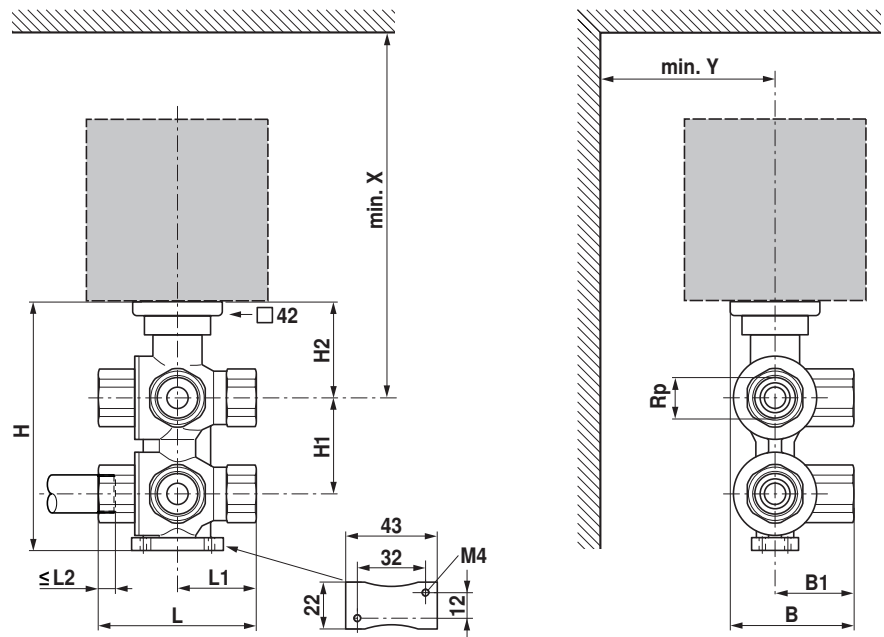

The actuator dimensions can be found on the respective actuator data sheet.

Type	DN	Rp	L	L1	L2	B	B1	H	H1	H2	X	Y	Weight ca.
	[ ]	["]	[ mm]	[ mm]	[ mm]	[ mm]	[ mm]	[ mm]	[ mm]	[ mm]	[ mm]	[ mm]	[ kg]
R3015-...-B2	15	1/2	79	39.5	13	54	33	119	45	47	200	40	1.1
R3020-...-B2	20	3/4	100	50	14	70	43	148	59	54	230	40	2.1

**Further documentation**

- Overview Valve-actuator combinations
- Data sheets for actuators
- Installation instructions for actuators and/or ball valves
- Notes for project planning for 6-way characterised control valves