EMICON

CLIMATE SOLUTIONS

EMIBYTE

DIRECT EXPANSION AIR CONDENSED CLOSE CONTROL UNITS

DXi.A
WITH INVERTER COMPRESSORS

DX.A
WITH ON/OFF COMPRESSORS



USE AND MAINTENANCE TECHNICAL MANUAL

The instructions unit manual is composed by the following:

- Conformity declaration
- Technical Manual



Instructions:
Referring to the specify



Read and understand all
the present Manual before
any intervention.

PRESERVE THE PRESENT FOR FUTURE

The copy, transmission or memorization of the present Manual is forbidden in any form without the written authorisation from the Manufacturer.

The Manufacturer could be contacted to receive any information about his products.

The Manufacturer works in a constant policy of products development and reserves the right to modify his products, the specifics and the instructions about use and maintenance without any prior notice.

Conformity declaration

We declare under our responsibility that the supplied units comply in every part with the directives of the CE marking and the current EN standards. The Conformity declaration is attached to the onboard documentation. Be informed that the unit contains fluorinated greenhouses gases.

INDEX

1. INTRODUCTION	5
1.1 Preliminary information	5
1.2 Instructions content and purpose	5
1.3 Instruction conservation	5
1.4 Instruction updating	5
1.5 Instruction use	5
1.6 Residual risks	6
1.7 Safety symbols generality	7
1.8 Safety symbols	8
1.9 Unit limit and not allowed usesi	8
1.10 Unit identification	9
2. SAFETY	10
2.1 Advise about toxic substances potentially dangerous	10
2.2 First AID and injuries prevention	10
2.3 Toxic information about the refrigerant fluid used	11
2.4 First AID measures	11
3. TECHNICAL CHARACTERISTICS	12
3.1 Unit description	12
3.2 Configurations	14
3.3 Accessories description	15
3.4 DXi.A series technical data	17
3.5 DX.A series technical data	20
3.6 Refrigerant charge	24
3.7 Remote condensers technical data	25
3.8 Matching between indoor unit and remote condenser	27
3.9 Operation limits	31
3.10 DXi.A Sound data	32
3.11 DX.A Sound data	34
4. INSTALLATION	37
4.1 General advices and symbols use	37
4.2 Workers health and safety	37
4.3 Individual protection devices	37
4.4 Receipt and inspection	38
4.5 Storage and transport	38
4.6 Unpacking	38
4.7 Lifting and handling	39
4.8 Location and minimum technical clearances	39
4.9 Hydraulic connections	40
4.10 Pipeline diameters	43
4.11 Tightness test, vacuum and charge	47
4.12 Refrigerant charge execution	50
4.13 DXi.A Refrigerant circuit layout	52
4.14 DX.A Refrigerant circuit layout	56
4.15 Condensing water connection	59
4.16 Renewal air intake connection (Optional) (PR)	59
4.17 Humidifier (optional) (H)	60
4.18 Electric connections: safety preliminary advices	61
4.19 Electrical data	61
4.20 Power supply connection	63
4.21 RS485 Serial interface	64
5. START UP	65
5.1 Preliminary checks	65
5.2 First start up	66
5.3 Operation checks	66
5.4 Safety valves	67

5.5 Safety devices calibration	67
6. USE	68
6.1 Electronic microprocessor control description and use	68
6.2 Remote control description	68
6.3 Keys function	70
6.4 User interface	70
6.5 Password settings.....	71
6.6 Quick access Menu	71
6.7 Main Menu	77
7. UNIT MAINTENANCE	86
7.1 General advices.....	86
7.2 Unit access	86
7.3 Scheduled maintenance	86
7.4 Periodical checks.....	89
7.5 Straordinary maintenance.....	90
8. DECOMMISSIONING.....	91
8.1 Disconnect the unit	91
8.2 Disposal, recovery and recycling.....	91
8.2 RAEE Directive (UE members only).....	92
9. DIAGNOSIS AND TROUBLESHOOTING	92
9.1 Fault finding	92

1. INTRODUCTION

1.1 Preliminary information

The copy, transmission or memorisation of the present Manual is forbidden in any form without the written authorisation from the Manufacturer.

The unit which the present Manual refers is designed only for the uses presented in the following pages, comply with their performances and characteristics. Any contractual or extra-contractual liability of the Manufacturer for damages caused to people, animals, things or environment made by installation, regulation, maintenance errors or improper uses are excluded

All the uses not mentioned in the present Manual are not allowed.

The present documentation is an informative support and has not to be considered as a contract with third parts.

The Manufacturer works in a constant policy of products development and reserves the right to modify his products, the specifics, the instructions and also the documentation in any moment without any prior notice

1.2 Instructions content and purpose

The present instructions purpose to give all information concerning the selection, installation, use and maintenance of the units.

The instructions are written in conformity with legislative disposition of UE and to the technical available norms.

The instructions including the indication to avoid reasonably foreseeable improper uses of the units.

1.3 Instruction conservation

The instruction must be posed in a proper place, away from dust, humidity and where every person in charge to use and operate with the unit could find them easily

The instruction has to be always on board and during all the life cycle of the unit, therefore has to be transferred to every subsequent user

1.4 Instruction updating

Is suggested to verify that all the instructions are updated to the last release available.

Any updates sended to the user must be kept attached to the present Manual.

The Manufacturer is available to provide any information about use of his products.

1.5 Instruction use

The present instructions are integral part of the unit which are referred.



The users and operators have to consults mandatory the instructions before any intervention on the units and in every occasion of doubt about the transport, the handling, the installation, the maintenance, the use and the disposal of the unit.



In the following are mentioned all the graphic symbols which indicate all the operation has to be safety done

1.6 Residual risks

The units are designed to reduce at minimum the risk for the people who will use them.

Anyway is impossible to eliminate completely the risk, so is strictly necessary refers to the following prescription in order to avoid them at the maximum.

ELEMENTS CONSIDERED (if presents)	RESIDUAL RISK	MODE	PRECAUTIONS
Exchanger coils	Small cutting wounds	Contact	Avoid the contact, use protective gloves.
Fans and grid fans.	Injury	Insertion of tools through the fans grid during the fans operation	Do not insert any tools throught the fans grid during their operation
Inside unit: compressors and discharge gas pipes	Burns	Contact	Avoid the contact, use protective gloves
Inside unit: metallic components and electrical cables.	Electrocution, several burns	Power supply cables insulation defect, electrical tension on metallic components.	Adequate supply line electrical protection; utmost care making the metallic parts ground connection.
Outside unit: Area around the unit	Intoxicaions, several burns	Fire due to short-circuit or overheating of the power supply line upstream of the unit's electrical panel	Section of the cables and protection system of the power supply line complying with the standard in force
High pressure safety valve (if present)	Intoxications, several burns, hearing loss	High pressure valve intervention with the cooling circuit panel open	Avoid opening the refrigeration circuit compartment as much as possible; carefully check the value of intervention of the condensation pressure valve; use all the high pressure personal protection safety devices required by law. Use all the personal protection devices required by law. PPE must also protect against gas leakage from the safety valve. The discharge of these valve is director to prevent damage to people or things.
Unit	Burst, injuries, burns, poisoning due to external incense.	Fire due to natural disaster or combustion of elemets adjacent to the unit.	Prepare the necessary fire-fighting equipment and / or adequate signals indicating that the uniti s under pressure
Unit	Burst, injuries, poisoning, electrocution due to natural disasters, earthquake	Breaks, sagging for natural disasters or earthquake	Prepare the necessary precautions, both electrical (adequate thermal magnetic circuit breaker and electrical protection of the power supply lines; treatment for maximum calamity when connecting the metal parts to earth, and mechanical (for example special antisismic anchors or anti-vibration dampers to avoid cause accidentals breakages or falls).

1.7 Safety symbols generality

ISO 3864-2 complied safety symbols :

**PROHIBITION**

Black symbol inside a red circle with red diagonal indicates a forbidden action.

**ADVISE**

A black graphic symbol inside a yellow triangle with black edges indicates a danger.

**MANDATORY ACTION**

A white symbol inside in a blue circle indicates a mandatory action to avoid a risk.

ISO 3864-2 complied Combined safety symbols:



The advise graphic symbol is completed with additional safety information (text or many symbols).

1.8 Safety symbols



GENERIC DANGER

Follow strictly all the advises near the symbol.
Failure to follow the indications could generate user health risks.



ELECTRICAL DANGER

Follow strictly all the advises near the symbol.
The symbol indicates unit components or, in the present Manual actions could generate electrical risks.



MOVING COMPONENTS

The symbols indicates unit's moving components could generate risk situations.



HOT SURFACES

The symbols indicates unit's components could be very hot and that could cause several burns.



SHARP SURFACES

The symbol indicates unit components could cause cutting wounds by contact.



GROUND CONNECTION

The symbol indicates the unit's ground connection point.



READ AND UNDERSTAND TEH INSTRUCTIONS

Read and understand the instruction before any intervention on the unit



RECOVERABLE OR RECYCLABLE MATERIAL

1.9 Unit limit and not allowed uses

Units are designed and produced exclusively for the uses described in the paragraph "Use limits" of technical Manual. Any other use is forbidden because could generate user health risks.



The unit is not suitable to operate in environments:

- Excessively dusty or potentially explosive;
- Where are present vibrations;
- Where are present electromagnetic fields;
- Where are present aggressive ambients.

1.10 Unit identification

Every unit has a plate which contains its main information. The plate data could be different from the technical Manual because in the Manual are mentioned the standard unit data without any accessory.

On the Serial number plate is also mentioned the refrigerant charge.

For the non mentioned electrical information refers to the Wiring diagram attached to the present Manual.

Following a FAC-SIMILE of the plate.

EMICON CLIMATE SOLUTIONS		<input checked="" type="checkbox"/> NB 0948					
TEL.+39 0543495611 FAX+39 0543 495612 Via A.Volta 49 Meldola FC ITALY							
MODELLO MODEL MODÈLE MODEL	<input type="text"/>	ANNO DI COSTRUZIONE / PED CATEGORIA MANUFACTURE YEAR / PED CATEGORY JAHR VON KONSTRUKT / PED KATEGORIE ANNI DE FABBRICA / CATEGORIE PED					
		2018					
MATRICOLA SERIAL NR N° DE SERIE STAMM NR	<input type="text"/>	CORRENTE MAX. MAX CURRENT INPUT MAXIMALEN STROM AMPÈRES MAXIMALE					
		A					
ALIMENTAZIONE ELET. SUPPLY VOLTAGE ALIMENTATION ELECT. SPANNUNG	<input type="text"/>	CARICA REFRIGERANTE REFRIGERANT CHARGE KALTEMITTEL CHARGE FRIGORIGÈNE					
		<table border="1"> <tr> <td>C1</td> <td>C2</td> <td rowspan="2">Kg. Ton</td> </tr> <tr> <td>C1</td> <td>C2</td> </tr> </table>	C1	C2	Kg. Ton	C1	C2
C1	C2	Kg. Ton					
C1	C2						
GAS REFRIGERAN REFRIGERANT RFRIGÉRANT KALTEMITTEL	R 410A / 2088	ASSORBIMENTO ELETTRICO NOMINALE PUISSANCE ÉLECTRIQUE NOMINALE NOMINAL ABSORBED POWER NOMINALE LEISTUNGSANNAHME					
		kW					
PESO OPERATIVO OPERATING WEIGHT POIDS OPERATION ARBEITSGEWICHT	Kg.	CORRENTE CORTOCIRCUITO SHORT CIRCUIT CURRENT COURANT COURT-CIRCUIT STROM KURZSCHLUSS					
		10 kA					
LATO BASSA PRESSIONE / LOW PRESSURE SIDE CIRCUIT BASSE PRESSION / NIEDERDRUCKSEITE		LATO ALTA PRESSIONE / HIGH PRESSURE SIDE CIRCUIT HAUTE PRESSION / HOCHDRUCKSEITE					
PRESSIONE DI PROGETTO DESIGN PRESSURE PRESSION DE PROJET DRUCK DES PROJEKTES	29,5 Bar	PRESSIONE DI PROGETTO PS DESIGN PRESSURE PS PRESSION DE PROJET PS DRUCK DES PROJEKTES PS					
		<input type="text"/> Bar					
TEMP MIN PROGETTO MINI DESIGN TEMPERATURE MINIÈRE TEMPS PROJETES TEMP MINIMALE DE PROJET	- 30 °C	TEMP MIN PROGETTO MINI DESIGN TEMPERATURE MINIÈRE TEMPS PROJETES TEMP MINIMALE DE PROJET					
		- 10 °C					
MAX TEMPERATURA PROGETTO MAX DESIGN TEMPERATURE MAXIMALE TEMPS PROJETES MAXIMALEN TEMP DE PROJET	+ 50 °C	MAX TEMPERATURA PROGETTO MAX DESIGN TEMPERATURE MAXIMALE TEMPS PROJETES MAXIMALEN TEMP DE PROJET					
		+120 GAS °C + 65 LIQU					
		TARATURA ORGANO SICUREZZA SETTING OF SAFETY DÉVISE MISE AU POINT DISPOSITIF DE SÉCURITÉ EINSTELLWERT SICHERHEITSELEMENT					
		<input type="text"/> Bar					
- "apparecchiatura che contiene gas fluorurati ad disciplinati dal protocollo di Kyoto"		effetto serra					
- "equipment that contains fluorinated greenhouse covered by the Kyoto protocol"		gases					
- "équipement qui contient des gaz fluorés à effet couverts per le protocole de Kyoto"		de serre					
- "Maschine die enthalt fluorierte Treibhausgase en durch das Kyoto-protokoll fallen"		thatt					



THE PLATE HAS NOT TO BE MOVED FROM THE ORIGINALLY POSITION

2. SAFETY

2.1 Advise about toxic substances potentially dangerous

2.1.1 Used fluid identification: R410A

- Difluoromethan (HFC-32) 50% weight CAS No.: 000075-10-5
- Pentafluoroethan (HFC-125) 50% weight CAS No.: 000354-33-6

2.1.2 Used oil identification:

The oil used into the unit cooling circuit is polyester type. Anyway refers always to the compressor's plate.



For any information about refrigerant or oil characteristics please refers to Safety Schede which is possible to find to their Producers.

Main ecological information about cooling fluids used.



ENVIRONMENT DEFENCE: Read carefully the following ecological information and instructions.

2.1.3 Persistence and degradation

The cooling fluids used decompose at the inferior atmosphere (troposphere) relatively quickly; decomposed they are highly dispersible so the concentration will be really low. They don't influence the photochemical smog and are not included in volatile organic compounds VOC (UNECE agreement).

Used refrigerants don't damage the ozone layer, there are regulated by the Montreal protocol (1992 release) and the CE 2037/200 of 29/06/2000 regulation.

2.1.4 Effects on effluents treatment

The release into the atmosphere of these products do not cause lon-term water contamination

2.1.5 Individual exposing and protection control

Is suggested to use clothes and protective gloves; is reccomended to always protect face and eyes.

2.1.6 Professional limit esposing

R410A

HFC-32	TWA 1000 ppm
HFC-125	TWA 1000 ppm

2.2 First AID and injuries prevention



The users and maintenance technicians has to be well informed about risks of toxic potentially fluids. Failure to observe the mentioned indications could cause damages to people or to unit.

2.2.1 High quantity steam inhalation

The atmospheric refrigerant concentration has to be minimum reduced (lower than overmentioned professional exposition limit). Be informed that the steam is heavier than air so high concentrations can stay near the ground, where the general ventilation is low, it is suggested to ensure an adequate ventilation in order to avoid it.

Avoid contact with free flames and hot surfaces because toxic and irritating decomposition products can be formed.

Avoid contact between the liquid and the skin or the eyes.

2.2.2 Accidental refrigerant leak procedures

During the cleaning operation be sure to have the adequate safety protection (using respiratory breathways protections)

If the conditions are sufficiently safe, isolate the leak source, if the leak is limited leave the evaporation refrigerant free ensuring a good ventilation.

Otherwise if the leak is large ensure a good ventilation, contain spilled material with sand, earth or other suitable absorbent material; prevent that the refrigerant enter into drains, sewers, basements or work holes in order to avoid suffocating vapors formation.

2.3 Toxic information about the refrigerant fluid used

2.3.1 Inhalation

A great atmospheric concentration can cause anesthetic effects combined with loss of consciousness. Long expositions can cause abnormal heart rhythm and even sudden death.

More elevated concentrations can cause asphyxia for reduced oxygen content in the air.

2.3.2 Skin contact

Splashes of sprayed refrigerant can cause frost burns. It is unlikely to be dangerous due to skin absorption; Prolonged and repeated contact may cause removal of skin fat, dryness and dermatitis.

2.3.3 Eyes contact

Splashes of sprayed refrigerant can cause frost burns.

2.3.4 Ingestion

Highly unlikely but can cause frost burns.

2.4 First AID measures



Follow strictly the following advises and the first AID procedures.

2.4.1 Inhalation

Remove injured person from the source of exposure, keep him warm and at rest. If necessary administer some oxygen; practice artificial respiration if breathing has stopped or any signs of stopping occurs.

If there is cardiac arrest perform cardiac massage; request medical assistance

2.4.2 Skin contact

In case of skin contact wash immediately with warm water; if necessary thaw the epidermal tissue with water. Remove contaminated clothing which can stick to skin in case of frost burns. If there is irritation or blistering, request medical assistance.

2.4.3 Eyes contact

Wash immediately with eye washing solution or with clean water, keep eyelids open for at least two minutes; request medical assistance.

2.4.4 Ingestion

Do not induce vomiting, if the injured person is conscious rinse mouth with water and allow 200-300 ml of water to be drunk; request medical assistance.

2.4.5 Further medical treatment

Symptomatic treatment and supportive therapy as indicated; do not administer adrenaline and sympathomimetic drugs as a result of exposure, due to the risk of cardiac arrhythmia.

3. TECHNICAL CHARACTERISTICS

3.1 Unit description

DXi.A and DX.A close control unit are designed and product in compliance with 9001:2015 ISO norms for technological plants of conditioning, data center, for UPS and all the ambients where are needed special conditions and a strictly control.

The units are suitable for internal installation.

DXi.A and DX.A units are built with the most advanced industry technology, including variable speed compressors equipped with brushless permanent magnets (BLDC for DXi.A serie) and fans with electronic commutated motor (EC).

BLDC compressors are driven by an inverter with 0-10V signal sent by the controller; they are able to vary the load continuously and the cooling circuit regulation easily fits to operating conditions required

EC centrifugal fans allow the continue speed regulation usina an analogic 0-10V signal sent from the controller; thanks to technology used the fans ensure reduced absorption compared to traditional centrifugal fans allow to adjust the air flow to the system required prevalence.

The following configurations are available for the direct expansion DXi.A and DX.A series :

• DXi.A e DX.A series:

- Up configuration (U) (suction air from the front and discharge to the top of the unit);
- Vertical configuration (V) (suction air from the bottom and discharge to the top of the unit);
- Down configuration (D) (suction air from the top and discharge to the bottom of the unit).
- Bottom configuration (B) (suction air from the back and discharge to the top of the unit).

This diversification can satisfy almost every customer's request from management point of view and the air flow rate.

3.1.1 BLDC scroll or rotary hermetic compressor type (DXi.A series), ON/OFF scroll or rotary compressor type (DX.A series)

All the DXi.A series models are provided with a BLDC hermetic compressor (with brushless permanents magnets motor) rotary or scroll type, suitable for functioning with R410a refrigerant. All the DX.A series models are provided with ON/OFF rotary or scroll hermetic compressors.

Each compressor is installed on a rubber-type vibration dampers and are equipped with:

- Oil carter, where the crankcase heater is installed (only Scroll);
- Thermistor included protection for the overloads;
- Polyester oil charge.

The compressor's terminal board has IP54 protection

Starts and stops of compressors are directly managed by the unit controller which in this way modulates the cooling capacity.

For rotary type compressors an equalization pressure valve is provided.

3.1.2 Frame

The modular structure of this equipment is made up of press-formed section in galvanized sheet elements painted with a RAL 9004 epoxy powder cycle.

The elements are assembled together to make up a sturdy frame, capable of supporting units parts and to sustain strain which may derive from unit handling and operation.

The devices are arranged inside the frame in a way that they are easy to reach from the front, to make necessary handling during unit operation and easier and more safety maintenance.

3.1.3 EC Radial fans

The units are supplied with backward curved blades radial fans in composite material equipped with high efficiency brushless EC motor. The electric motor is suitable to be used at a variable rotation speed managed usign the controller with 0-10V signal. The blades, with a backward profile, specifically designed to maximize the efficiency and reduce sound emission, are directly coupled with the electronically commutated motor equipped with internal thermal protection.

For further details on controlling the EC fans (rate calibration and static counter-pressure) please refer to the Microprocessor's Manual.

3.1.4 Direct expansion coil with hydrophilic treatment

The cooling coil has been designed with a great front surface in order to have an high SHR (Sensible Heat Ratio) and a low airflow speed in order to avoid the condensate to detach, to reduce air pressure drop and to guarantee an higher efficiency of the heat exchange both during the cooling and the dehumidification process.

The coil is made up of copper tubes mechanically expanded on hydrophilic treated aluminium fins, treatment that allows to reduce the surface tension between water and metal surface, providing a film condensation and avoiding the drain of condensate outside the drip tray. The drip tray is made up of painted and galvanized sheet or in peraluman (aluminium and magnesium alloy).

All the coils are factory tested and cleaned before their installation by the Manufacturer.

3.1.5 Electrical board

The unit electrical board is in compliance with the European regulations in force and has been realised inside a metal compartment: The main characteristics are the following:

- Three phase power supply 400/3/50+N+PE on all units, unless different special requests are demanded;
- Auxiliary circuit in low voltage 24Vac with isolation transformer;
- Main switch (mechanical interlock is an optional);
- Terminal board for signal and control free contacts;

In this compartment, which access is allowed by a main switch, contains moreover the following main devices:

- Contactors;
- Transformers;
- Numbered conductors;
- Low tension auxiliary circuits;
- Terminal boards;
- Electronic cards to manage and control.

All units undergo a safety cycle with continuity test on protection conductors, insulation resistance and withstanding test. The unit control is managed by controller program installed on the Microprocessor onboard.

3.1.6 Controller

The unit manage electronic controller is installed in the electrical board and it has the cooling capacity regulation control through the air temperature measure (evaporator inlet-outlet double check), operation parameters check, equalizer and hour counte (options), troubleshooting autodiagnosys, alarm log memorization, switch on time and set point value programming, remote control of the unit using the standard communication protocols installed in the Microprocessor.

3.1.7 Frequence converter (inverter) (DXi.A series)

All the DXi.A models are provided with an inverter able to manage the compressors with permanent brushless magnets BLDC. The inverter wollows the CE norm and is equipped with integrated EMC filter C3, control panel and cooling fan.

3.1.8 Tests

Once the uniti s complete, the cooling circuiti s completely tested (following the Manufacturer Warraty procedures) to a pressure and leak test to find any losses.

Before the delivery the unit is subjects to a complete functional test.

3.1.9 DXi.A and DX.A nomenclature

Following is shown the unit name meanings:

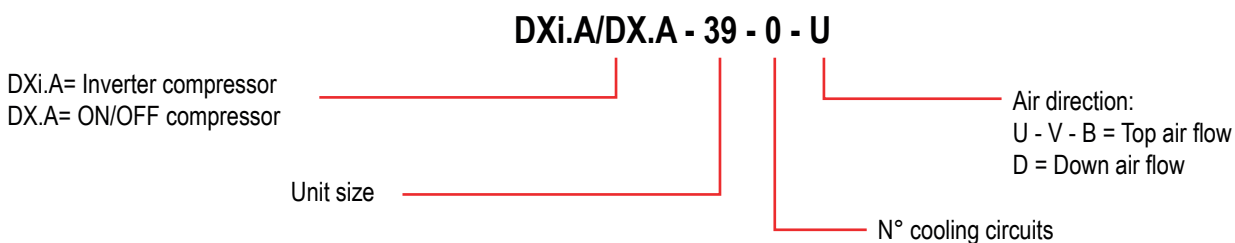

3.2 Configurations

DXi.A/DX.A - U

Front suction
Up discharge

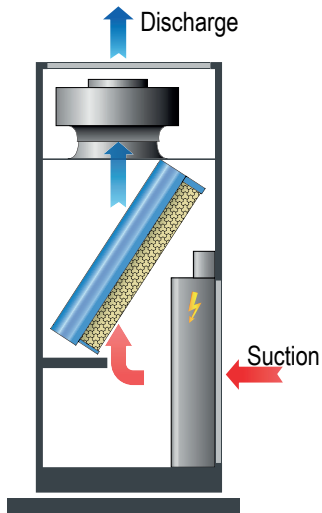

DXi.A/DX.A - V

Down suction
Up discharge

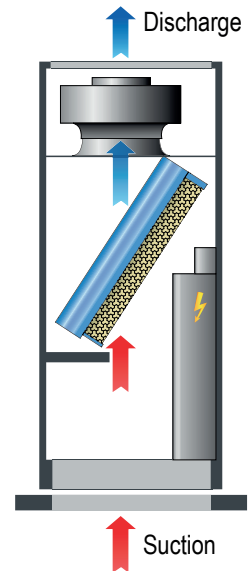

DXi.A/DX.A - D

Up suction
Down discharge

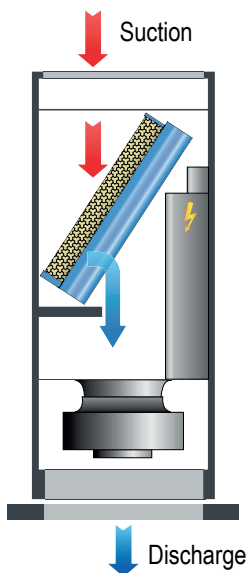

DXi.A/DX.A - B

Behind suction
Up discharge

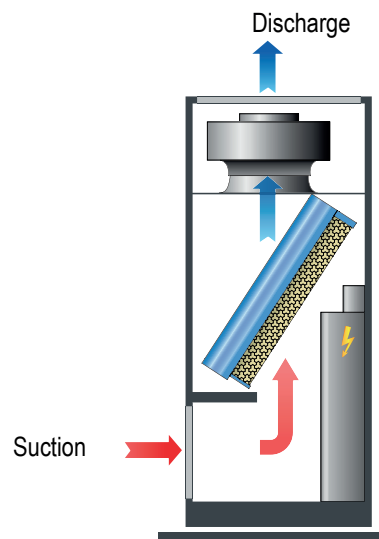

3.3 Accessories description

- AA Flooding alarm:** Water sensible probe, is already wired by Manufacturer. This option has to be installed under the unit by the unit installation technicians.
- AE Electrical power supply different from standard:** Manily, 230V three phase, 460V three phase, with 50/60Hz of frequency.
- AL Smoke alarm:** Smoke sensible probe installed inside of the unit which activate an alarm in case of smoke presence which stops the fans and compressors.
- B Basement:** Suitable for installation on raised floors, it can be regulate from 170mm to 600mm. It is provided with adjustable feets.
- BAS Baseframe for lateral connections.**
- BC Hot water coil:** One or two-row water coil, placed after the cooling coil to re-heating and/or the heating of treated air; provided with modulating actuator and with three-way valve and controlled by the on board microprocessor. This option has the priority when requested with the electric heaters (RE option).
- BG Hot gas coil:** One pr two-row water coil, placed after the cooling coil to re-heating of treated air; provided with three-way valve (ON/OFF type) and controlled by the onboard microprocessor.
- DH Dehumidification control system:** Composed by a humidity probe.
- DP Double panels:** Internal panels for closing the compartments affected by the air flow made with profiles in galvanized pre-painted sheet steel, which allow the reduction of the noise transmitted through the paneling and a better air tightness even without external panels; it allows the unit operation also during maintenance operations with the panels removed, such as filter replacement.
- EPM6, EPM7 Air filter options:** Flat efficiency filters ePM10 and ePM1 50% supplied as an option as an alternative to standards ones.
- FR Spare filters kit COARSE 60%:** in alternative to to standard ones.
- FRM6 Spare filters kit:** ePM10 60%.
- FRM7 Spare filters kit ePM1 50%,.**
- H Humidifier:** Immerse-electrode type for the modulating production of steam; it is made of a steam cylinder, a steam distributor, water inlet and outlet valves and a maximum water level probe. The onboard microprocessor indicates when the steam cylinder needs to be replaced in order to be able to make a maintenance during the unit operation.
- IE Fumigated wooden crate packing:** Available on request for critical transports in order to assure a protection to the unit.
- IH RS485 Protocol serial interface:** Allows the communication between the unit and an external supervision system (the external supervision system and the communication software are not provided with the unit; please contact the Manufacturer in order to have more info about the available communication protocols).
- IH-BAC BACNET Protocol Serial Interface:** Gateway to be connected to the microprocessor to allow the connection between the unit and an external supervision system with BACNET protocol, for a remote control and monitoring of the unit. (Alternative to IH, IH LON and IWG).
- IH-LON LON Protocol serial interface:** Gateway to be connected to the microprocessor to allow the connection between the unit and an external supervision system with LON protocol, for a remote control and monitoring of the unit. (Alternative to IH, IH BAC and IWG).
- IM Seawood packing:** Fumigated seawood case and protection bag with hygroscopic salts, suitable for long sea transports.
- IP Magnetothermic switches for auxiliary circuits:** Installed instead of fuses for auxiliary circuits protection.
- IS1 Class 1 insulation material:** In conformity to the main European regulations in force.
- IWG SNMP o TCP/IP Protocol serial interface:** Electronic card to be connected to the microprocessor to allow the connection between the unit and an external supervision system with SNMP or TCP/IP protocol, for a remote control and monitoring of the unit. (Alternative to IH, IH BAC and IH LON).
- MF Phase monitor:** Electronic device controlling the correct sequence and/or the eventual lack of one of the three phases switching off the unit if necessary.
- MN Neutral wire lack for 400/3/50 power supply:** Unit general power supply without neutral wire; for IT power supplies the Manufacturer has to release, after a check, the connection authorization.

- MP** **Advanced microprocessor card:** Contained the Ethernet gateway and Master&Slave
- PB** **Condensation water pumps:** Micro pump discharging the condensing water produced by the unit provided totally installed.
- PBH** **Humidifier and condensatcion water pump** Micro pump discharging the condensing water produced by the unit coupled with a humidifier provided in a kit for outdoor installation.
- PL** **Distribution plenum :** Provided with a frontal grid and a double raw of adjustable fins for a better air distribution (Only for WU series, U and V version).
- PQ** **Remote display:** Remote terminal which allows to display the temperature and humidity values detected by probes, the alarm digital inputs, the outputs and the remote ON/OFF of the unit, to change the program of the parameters, the sound signals and the display of the present alarms.
- PR** **Fresh air inlet:** External fresh air inlet with a flat filter, placed on unit side, with circular connection.
- RE** **Electrical heaters:** Made of aluminium and installed after the cooling coil, suitable for re-heating and/or heating of the treated air in order to compensate for the sensitive cooling of the system during the dehumidification cycle. The heating capacity is split on 3 steps max, so to reduce the energy consumptions. The heaters are managed by the onboard microprocessor meanwhile the electric protections managed by a magnetothermic switch.
- REM** **Oversized electrical heaters.**
- RV** **Personalized frame painting in RAL color.**
- SEP** **Set point compensation card (max 6 mt):** Composed by probes allows the set-point set according to the external air temperature
- STP** **Air flow stabilisation.**
- TS** **Touch screen graphic display:** The new settable electronic display allows to develope simples and appeal interfaces for the final users; the touch screen dispaly range can combine different colors and levels of transparency using Alpha Blending technology.

3.4 DXi.A series technical data

DXi.A		61	111	121	151	181	201	251	321
Cooling capacity (Total) ⁽¹⁾ ESP 20 Pa	kW	7,2	10,1	11,2	16,1	18,2	20,5	25,6	33,7
Cooling capacity (Sensible) ⁽¹⁾ ESP 20 Pa	kW	7,2	9,3	11,2	14,5	17,6	20,5	25,5	30,7
Tot. absorbed power ⁽²⁾ ESP 20 Pa	kW	2,3	3,5	3,7	4,6	5,1	5,3	7,2	8,6
SHR		1,00	0,92	1,00	0,91	0,97	1,00	1,00	0,91
Air flow	m ³ /h	3900	3900	3900	3900	5700	5700	8150	8150
Fan	n	1	1	1	1	1	1	1	1
Max. ESP	Pa	559	560	479	412	568	539	451	362
Unit EER without remote condenser to max. frequency	W/W	3,4	3,1	3,2	3,8	3,9	4,1	3,8	4,2
Maximum absorbed power	kW	4	6	6	9	11	11	12	15
Maximum absorbed current	A	14	18	18	16	21	21	21	24
starting current	A	4	4	4	4	7	7	6	6
Power supply	V/ph/Hz	400/3/50+N+PE							
Humidifier									
Steam production (nominal)	kg/h	3	3	3	3	5	5	8	8
Steam production (max.)	kg/h	3	3	3	3	8	8	8	8
Max. absorbed power	kW	2,25	2,25	2,25	2,25	3,75	3,75	6,0	6,0
Max. absorbed current	A	10,0	10,0	10,0	10,0	5,5	5,5	8,7	8,7
Specific conductivity at 20°C (min/max)	µS/cm	300/1250	300/1250	300/1250	300/1250	300/1250	300/1250	300/1250	300/1250
Total hardness (min/max)	mg/l CaCO ₃	100/400	100/400	100/400	100/400	100/400	100/400	100/400	100/400
Electrical heaters									
Steps	n°	3	3	3	3	2	2	3	3
Power	kW	4,5	4,5	4,5	4,5	6,0	6,0	9,0	9,0
Absorbed current	A	6,5	6,5	6,5	6,5	8,7	8,7	13,0	13,0
Oversized electrical heaters									
Steps	n°	2	2	2	2	3	3	3	3
Power	kW	6,0	6,0	6,0	6,0	9,0	9,0	12,0	12,0
Absorbed current	A	8,7	8,7	8,7	8,7	13,0	13,0	17,3	17,3
Hot water coil									
Heating capacity ⁽³⁾	kW	7,3	7,3	7,3	7,3	10,6	10,6	16,7	16,7
Water flow	m ³ /h	1,3	1,3	1,3	1,3	1,8	1,8	2,9	2,9
Pressure drop (coil + 3 way valve)	kPa	31	31	31	31	48	48	56	56
Coil internal volume	dm ³	1,4	1,4	1,4	1,4	2,1	2,1	3,3	3,3
Condensing water pump									
Nominal flow	l/h	390,0	390,0	390,0	390,0	390,0	390,0	390,0	390,0
Max. flow (prevalence = 0 m)	l/h	500	500	500	500	500	500	500	500
Max. discharge height (flow=0 m ³ /h)	m	5,4	5,4	5,4	5,4	5,4	5,4	5,4	5,4
Condensing water pump + humidifier									
Nominal flow	l/h	-	-	-	-	-	-	600	600
Max. flow (prevalence = 0 m)	l/h	-	-	-	-	-	-	900	900
Max. discharge height (flow=0 m ³ /h)	m	-	-	-	-	-	-	6,0	6,0
Dimensions and weight									
Frame	n°	2	2	2	2	3	3	4	4
Width	mm	750	750	750	750	980	980	1160	1160
Depth	mm	550	550	550	550	750	750	850	850
Height	mm	1980	1980	1980	1980	1980	1980	1980	1980
Weight (Configuration U)	Kg	198	205	209	219	284	292	331	362
Weight (Configuration V)	Kg	201	208	212	222	288	296	336	367
Weight (Configuration D)	Kg	203	209	213	223	290	298	338	369
Weight (Configuration B)	Kg	201	208	212	222	288	296	336	367

Performances are referred to the following conditions:

(1) Ambient temperature 24°C, Relative humidity 50%, Condensing temperature 48°C.

(2) The fans electrical power has to be added to the ambient load.

(3) Water temperature 40/45°C, Ambient temperature 20°C, Relative humidity 50%.

DXi.A		381	392	472	491	531	532	631	652
Cooling capacity (Total) ⁽¹⁾ ESP 20 Pa	kW	37,2	39,0	47,4	50,7	54,0	52,8	64,8	68,4
Cooling capacity (Sensible) ⁽¹⁾ ESP 20 Pa	kW	37,1	38,9	44,3	45,1	52,7	52,7	63,4	64,6
Tot. absorbed power ⁽²⁾ ESP 20 Pa	kW	10,1	10,5	13,4	13,9	14,1	14,6	16,7	17,5
SHR		1,00	1,00	0,93	0,89	0,97	1,00	0,98	0,95
Air flow	m ³ /h	11500	11500	11500	11500	14500	14500	17600	17600
Fan	n	1	1	1	1	2	2	2	2
Max. ESP	Pa	428	427	402	388	417	432	417	392
Unit EER without remote condenser to max. frequency	W/W	4	4	3,8	3,9	4,1	3,9	4,2	4,2
Maximum absorbed power	kW	16	19	21	23	24	23	28	31
Maximum absorbed current	A	26	38	40	34	37	42	47	48
starting current	A	8	24	25	8	10	27	156	30
Power supply	V/ph/Hz	400/3/50+N+PE							
Humidifier									
Steam production (nominal)	kg/h	8	8	8	8	8	8	8	8
Steam production (max.)	kg/h	8	8	8	8	8	8	8	8
Max. absorbed power	kW	6,0	6,0	6,0	6,0	6,0	6,0	6,0	6,0
Max. absorbed current	A	8,7	8,7	8,7	8,7	8,7	8,7	8,7	8,7
Specific conductivity at 20°C (min/max)	µS/cm	300/1250	300/1250	300/1250	300/1250	300/1250	300/1250	300/1250	300/1250
Total hardness (min/max)	mg/l CaCO ₃	100/400	100/400	100/400	100/400	100/400	100/400	100/400	100/400
Electrical heaters									
Steps	n°	3	3	3	3	3	3	3	3
Power	kW	9,0	9,0	9,0	9,0	15,0	15,0	18,0	18,0
Absorbed current	A	13,0	13,0	13,0	13,0	21,7	21,7	26,0	26,0
Oversized electrical heaters									
Steps	n°	3	3	3	3	3	3	3	3
Power	kW	12,0	12,0	12,0	12,0	18,0	18,0	24,0	24,0
Absorbed current	A	17,3	17,3	17,3	17,3	26,0	26,0	34,6	34,6
Hot water coil									
Heating capacity ⁽³⁾	kW	24,5	24,5	24,5	24,5	31,1	31,1	37,4	37,4
Water flow	m ³ /h	4,3	4,3	4,3	4,3	5,43	5,43	6,5	6,5
Pressure drop (coil + 3 way valve)	kPa	46	46	46	46	53	53	34	34
Coil internal volume	dm ³	4,7	4,7	4,7	4,7	5,8	5,8	7,1	7,1
Condensing water pump									
Nominal flow	l/h	390,0	390,0	390,0	390,0	390,0	390,0	390,0	390,0
Max. flow (prevalence = 0 m)	l/h	500	500	500	500	500	500	500	500
Max. discharge height (flow=0 m ³ /h)	m	5,4	5,4	5,4	5,4	5,4	5,4	5,4	5,4
Condensing water pump + humidifier									
Nominal flow	l/h	600	600	600	600	600	600	600	600
Max. flow (prevalence = 0 m)	l/h	900	900	900	900	900	900	900	900
Max. discharge height (flow=0 m ³ /h)	m	6,0	6,0	6,0	6,0	6,0	6,0	6,0	6,0
Dimensions and weight									
Frame	n°	4,5	4,5	4,5	4,5	5	5	6	6
Width	mm	1505	1505	1505	1505	1860	1860	2210	2210
Depth	mm	850	850	850	850	850	850	850	850
Height	mm	1980	1980	1980	1980	1980	1980	1980	1980
Weight (Configuration U)	Kg	416	433	435	419	509	525	606	620
Weight (Configuration V)	Kg	421	439	441	425	516	531	614	627
Weight (Configuration D)	Kg	424	442	443	428	519	535	617	631
Weight (Configuration B)	Kg	421	439	441	425	516	531	614	627

Performances are referred to the following conditions:

(1) Ambient temperature 24°C, Relative humidity 50%, Condensing temperature 48°C.

(2) The fans electrical power has to be added to the ambient load.

(3) Water temperature 40/45°C, Ambient temperature 20°C, Relative humidity 50%.

DXi.A		691	742	761	861	931	952	1021	1142
Cooling capacity (Total) ⁽¹⁾ ESP 20 Pa	kW	70,1	74,9	78,2	85,8	94,7	96,5	100,7	109,8
Cooling capacity (Sensible) ⁽¹⁾ ESP 20 Pa	kW	66,3	74,7	75,2	80,2	91,6	93,9	96,1	98,8
Tot. absorbed power ⁽²⁾ ESP 20 Pa	kW	18,8	19,9	20,2	23,7	24	25,9	27,6	30,8
SHR		0,95	1,00	0,96	0,94	0,97	0,97	0,95	0,90
Air flow	m ³ /h	17600	20900	20900	20900	25700	25700	25700	25700
Fan	n	2	2	2	2	3	3	3	3
Max. ESP	Pa	432	437	436	429	446	449	442	431
Unit EER without remote condenser to max. frequency	W/W	4	4,1	4,2	3,9	4,3	4	3,9	3,9
Maximum absorbed power	kW	30	33	36	38	45	49	47	56
Maximum absorbed current	A	50	51	58	61	76	74	79	93
starting current	A	167	33	168	179	185	47	219	203
Power supply	V/ph/Hz	400/3/50+N+PE							
Humidifier									
Steam production (nominal)	kg/h	8	8	8	8	8	8	8	8
Steam production (max.)	kg/h	8	8	8	8	8	8	8	8
Max. absorbed power	kW	6,0	6,0	6,0	6,0	6,0	6,0	6,0	6,0
Max. absorbed current	A	8,7	8,7	8,7	8,7	8,7	8,7	8,7	8,7
Specific conductivity at 20°C (min/max)	µS/cm	300/1250	300/1250	300/1250	300/1250	300/1250	300/1250	300/1250	300/1250
Total hardness (min/max)	mg/l CaCO ₃	100/400	100/400	100/400	100/400	100/400	100/400	100/400	100/400
Electrical heaters									
Steps	n°	3	3	3	3	3	3	3	3
Power	kW	18,0	24,0	24,0	24,0	27,0	27,0	27,0	27,0
Absorbed current	A	26,0	34,6	34,6	34,6	39,0	39,0	39,0	39,0
Oversized electrical heaters									
Steps	n°	3	3	3	3	3	3	3	3
Power	kW	24,0	27,0	27,0	27,0	36,0	36,0	36,0	36,0
Absorbed current	A	34,6	39,0	39,0	39,0	52,0	52,0	52,0	52,0
Hot water coil									
Heating capacity ⁽³⁾	kW	37,4	48,9	48,9	48,9	60,8	60,8	60,8	60,8
Water flow	m ³ /h	6,5	8,5	8,5	8,5	10,6	10,6	10,6	10,6
Pressure drop (coil + 3 way valve)	kPa	34	48	48	48	42	42	42	42
Coil internal volume	dm ³	7,1	10,45	10,45	10,45	12,6	12,6	12,6	12,6
Condensing water pump									
Nominal flow	l/h	390,0	390,0	390,0	390,0	390,0	390,0	390,0	390,0
Max. flow (prevalence = 0 m)	l/h	500	500	500	500	500	500	500	500
Max. discharge height (flow=0 m ³ /h)	m	5,4	5,4	5,4	5,4	5,4	5,4	5,4	5,4
Condensing water pump + humidifier									
Nominal flow	l/h	600	600	600	600	600	600	600	600
Max. flow (prevalence = 0 m)	l/h	900	900	900	900	900	900	900	900
Max. discharge height (flow=0 m ³ /h)	m	6,0	6,0	6,0	6,0	6,0	6,0	6,0	6,0
Dimensions and weight									
Frame	n°	6	7	7	7	8	8	8	8
Width	mm	2210	2565	2565	2565	3100	3100	3100	3100
Depth	mm	850	850	850	850	850	850	850	850
Height	mm	1980	1980	1980	1980	1980	1980	1980	1980
Weight (Configuration U)	Kg	606	717	710	710	869	878	869	954
Weight (Configuration V)	Kg	614	725	719	719	880	888	880	965
Weight (Configuration D)	Kg	617	729	723	723	885	893	885	970
Weight (Configuration B)	Kg	614	725	719	719	880	888	880	965

Performances are referred to the following conditions:

(1) Ambient temperature 24°C, Relative humidity 50%, Condensing temperature 48°C.

(2) The fans electrical power has to be added to the ambient load.

(3) Water temperature 40/45°C, Ambient temperature 20°C, Relative humidity 50%.

3.4 DX.A series technical data

DX.A		61	71	91	111	151	181	201	221	232
Cooling capacity (Total) ⁽¹⁾ ESP 20 Pa	kW	6,1	8,4	9,9	11,2	15,9	18,4	20,1	22,6	22,9
Cooling capacity (Sensible) ⁽¹⁾ ESP 20 Pa	kW	6	8	9,6	11,2	14,5	17,9	20	21,7	22,9
Tot. absorbed power ⁽²⁾ ESP 20 Pa	kW	1,9	2,5	2,7	3,6	4,6	5,4	5,5	6,4	6,9
SHR		0,99	0,96	0,97	1,00	0,91	0,97	1,00	0,96	1,00
Air flow	m ³ /h	2700	2700	2700	3900	3900	6050	6050	6050	8150
Fan	n°	1	1	1	1	1	1	1	1	1
Max. ESP	Pa	542	521	479	506	465	655	612	612	446
Unit EER without remote condenser to max. frequency	W/W	3,2	3,3	3,7	3,1	3,5	3,4	3,7	3,5	3,3
Maximum absorbed power	Kw	3,8	4,5	5	6,2	7,6	10,5	10,5	11,8	12
Maximum absorbed current	A	12,8	16,5	18,7	10,2	12,4	17	17	19,1	19,8
starting current	A	41,4	64,4	66,4	50,4	65,4	71	71	78	60
Power supply	V/ph/Hz	400/3/50+N+PE								
Humidifier										
Steam production (nominal)	kg/h	1,5	1,5	1,5	3	3	5	5	5	8
Steam production (max.)	kg/h	3	3	3	3	3	8	8	8	8
Max. absorbed power	kW	1,12	1,12	1,12	2,25	2,25	3,75	3,75	3,75	6,0
Max. absorbed current	A	5,0	5,0	5,0	10,0	10,0	5,5	5,5	5,5	8,7
Specific conductivity at 20°C (min/max)	µS/cm	300/1250	300/1250	300/1250	300/1250	300/1250	300/1250	300/1250	300/1250	300/1250
Total hardness (min/max)	mg/l CaCO ₃	100/400	100/400	100/400	100/400	100/400	100/400	100/400	100/400	100/400
Electrical heaters										
Steps	n°	1	1	1	1	1	2	2	2	3
Power	kW	3,0	3,0	3,0	4,5	4,5	6,0	6,0	6,0	9,0
Absorbed current	A	4,3	4,3	4,3	6,5	6,5	8,7	8,7	8,7	13,0
Oversized electrical heaters										
Steps	n°	1	1	1	2	2	3	3	3	3
Power	kW	4,5	4,5	4,5	6,0	6,0	9,0	9,0	9,0	12,0
Absorbed current	A	6,5	6,5	6,5	8,7	8,7	13,0	13,0	13,0	17,3
Hot water coil										
Heating capacity ⁽³⁾	kW	4,9	4,9	4,9	7,3	7,3	10,6	10,6	10,6	16,7
Water flow	m ³ /h	0,85	0,85	0,85	1,3	1,3	1,86	1,86	1,86	2,91
Pressure drop (coil + 3 way valve)	kPa	36	36	36	31	31	48	48	48	56
Coil internal volume	dm ³	1,1	1,1	1,1	1,4	1,4	2,1	2,1	2,1	3,3
Condensing water pump										
Nominal flow	l/h	27,5	27,5	27,5	390,0	390,0	390,0	390,0	390,0	390,0
Max. flow (prevalence = 0 m)	l/h	34	34	34	500	500	500	500	500	500
Max. discharge height (flow=0 m ³ /h)	m	15,0	15,0	15,0	5,4	5,4	5,4	5,4	5,4	5,4
Condensing water pump + humidifier										
Nominal flow	l/h	-	-	-	-	-	-	-	-	600
Max. flow (prevalence = 0 m)	l/h	-	-	-	-	-	-	-	-	900
Max. discharge height (flow=0 m ³ /h)	m	-	-	-	-	-	-	-	-	6,0
Dimensions and weight										
Frame	n°	1	1	1	2	2	3	3	3	4
Width	mm	550	550	550	750	750	980	980	980	1160
Depth	mm	550	550	550	550	550	750	750	750	850
Height	mm	1980	1980	1980	1980	1980	1980	1980	1980	1980
Weight (Configuration U)	Kg	169	179	182	223	230	293	301	301	385
Weight (Configuration V)	Kg	171	181	185	226	232	297	305	305	390
Weight (Configuration D)	Kg	172	182	186	228	234	299	307	307	392
Weight (Configuration B)	Kg	171	181	185	226	232	297	305	305	390

Performances are referred to the following conditions:

- (1) Ambient temperature 24°C, Relative humidity 50%, Condensing temperature 48°C.
- (2) The fans electrical power has to be added to the ambient load.
- (3) Water temperature 40/45°C, Ambient temperature 20°C, Relative humidity 50%.

DX.A		251	301	321	322	391	392	431	442	451
Cooling capacity (Total) ⁽¹⁾ ESP 20 Pa	kW	24,3	29,5	33,3	32,4	39,3	39,1	42,8	44	45,7
Cooling capacity (Sensible) ⁽¹⁾ ESP 20 Pa	kW	23,9	29,5	30,4	30,1	39,1	39	42,1	42,1	45,5
Tot. absorbed power ⁽²⁾ ESP 20 Pa	kW	6,7	7,7	8,8	9	10,1	11,2	11,3	12,9	11,4
SHR		0,99	1,00	0,91	0,93	1,00	1,00	0,98	0,96	1,00
Air flow	m ³ /h	8150	8150	8150	8150	11500	11500	11500	11500	14500
Fan	n°	1	1	1	1	1	1	1	1	2
Max. ESP	Pa	446	446	405	405	406	406	406	406	432
Unit EER without remote condenser to max. frequency	W/W	3,6	3,8	3,8	3,6	3,9	3,5	3,8	3,4	4
Maximum absorbed power	Kw	11,7	12,3	14,2	14,8	16,6	18,4	18,3	21	20
Maximum absorbed current	A	20,2	22,4	25,8	24,2	30,6	29,6	36,6	33,8	39,4
starting current	A	99,2	132,2	143,2	77,2	123,6	83,6	145,6	92,7	148,4
Power supply	V/ph/Hz	400/3/50+N+PE								
Humidifier										
Steam production (nominal)	kg/h	8	8	8	8	8	8	8	8	8
Steam production (max.)	kg/h	8	8	8	8	8	8	8	8	8
Max. absorbed power	kW	6,0	6,0	6,0	6,0	6,0	6,0	6,0	6,0	6,0
Max. absorbed current	A	8,7	8,7	8,7	8,7	8,7	8,7	8,7	8,7	8,7
Specific conductivity at 20°C (min/max)	µS/cm	300/1250	300/1250	300/1250	300/1250	300/1250	300/1250	300/1250	300/1250	300/1250
Total hardness (min/max)	mg/l CaCO ₃	100/400	100/400	100/400	100/400	100/400	100/400	100/400	100/400	100/400
Electrical heaters										
Steps	n°	3	3	3	3	3	3	3	3	3
Power	kW	9,0	9,0	9,0	9,0	9,0	9,0	9,0	9,0	15,0
Absorbed current	A	13,0	13,0	13,0	13,0	13,0	13,0	13,0	13,0	21,7
Oversized electrical heaters										
Steps	n°	3	3	3	3	3	3	3	3	3
Power	kW	12,0	12,0	12,0	12,0	12,0	12,0	12,0	12,0	18,0
Absorbed current	A	17,3	17,3	17,3	17,3	17,3	17,3	17,3	17,3	26,0
Hot water coil										
Heating capacity ⁽³⁾	kW	16,7	16,7	16,7	16,7	24,5	24,5	24,5	24,5	31,1
Water flow	m ³ /h	2,91	2,91	2,91	2,91	4,3	4,3	4,3	4,3	5,43
Pressure drop (coil + 3 way valve)	kPa	56	56	56	56	46	46	46	46	53
Coil internal volume	dm ³	3,3	3,3	3,3	3,3	4,7	4,7	4,7	4,7	5,8
Condensing water pump										
Nominal flow	l/h	390,0	390,0	390,0	390,0	390,0	390,0	390,0	390,0	390,0
Max. flow (prevalence = 0 m)	l/h	500	500	500	500	500	500	500	500	500
Max. discharge height (flow=0 m ³ /h)	m	5,4	5,4	5,4	5,4	5,4	5,4	5,4	5,4	5,4
Condensing water pump + humidifier										
Nominal flow	l/h	600	600	600	600	600	600	600	600	600
Max. flow (prevalence = 0 m)	l/h	900	900	900	900	900	900	900	900	900
Max. discharge height (flow=0 m ³ /h)	m	6,0	6,0	6,0	6,0	6,0	6,0	6,0	6,0	6,0
Dimensions and weight										
Frame	n°	4	4	4	4	4,5	4,5	4,5	4,5	5
Width	mm	1160	1160	1160	1160	1505	1505	1505	1505	1860
Depth	mm	850	850	850	850	850	850	850	850	850
Height	mm	1980	1980	1980	1980	1980	1980	1980	1980	1980
Weight (Configuration U)	Kg	342	360	361	398	429	454	433	454	522
Weight (Configuration V)	Kg	346	365	365	403	434	459	438	459	528
Weight (Configuration D)	Kg	349	367	368	405	437	462	441	462	531
Weight (Configuration B)	Kg	346	365	365	403	434	459	438	459	528

Performances are referred to the following conditions:

- (1) Ambient temperature 24°C, Relative humidity 50%, Condensing temperature 48°C.
- (2) The fans electrical power has to be added to the ambient load.
- (3) Water temperature 40/45°C, Ambient temperature 20°C, Relative humidity 50%.

DX.A		472	511	512	531	602	672	742	761
Cooling capacity (Total) ⁽¹⁾ ESP 20 Pa	kW	47,3	51	50,9	53,2	59,8	67,3	74,3	77
Cooling capacity (Sensible) ⁽¹⁾ ESP 20 Pa	kW	47,1	50,8	50,7	53,1	59,7	64	66,8	76,6
Tot. absorbed power ⁽²⁾ ESP 20 Pa	kW	12,9	13,3	13,5	13,9	15,6	17,8	19,5	20
SHR		1,00	1,00	1,00	1,00	1,00	0,95	0,90	1,00
Air flow	m ³ /h	14500	14500	14500	17600	17600	17600	17600	20900
Fan	n	2	2	2	2	2	2	2	2
Max. ESP	Pa	432	432	432	382	383	382	383	436
Unit EER without remote condenser to max. frequency	w/w	3,7	3,8	3,8	3,8	3,8	3,8	3,8	3,8
Maximum absorbed power	Kw	22,7	22,2	23,4	22,2	24,6	28,4	31,3	33,2
Maximum absorbed current	A	36,6	42,4	40,4	42,4	44,8	51,6	58,4	61,2
starting current	A	95,5	182,4	119,4	182,4	154,6	169,0	151,4	154,2
Power supply	V/ph/Hz	400/3/50+N+PE							
Humidifier									
Steam production (nominal)	kg/h	8	8	8	8	8	8	8	8
Steam production (max.)	kg/h	8	8	8	8	8	8	8	8
Max. absorbed power	kW	6,0	6,0	6,0	6,0	6,0	6,0	6,0	6,0
Max. absorbed current	A	8,7	8,7	8,7	8,7	8,7	8,7	8,7	8,7
Specific conductivity at 20°C (min/max)	µS/cm	300/1250	300/1250	300/1250	300/1250	300/1250	300/1250	300/1250	300/1250
Total hardness (min/max)	mg/l CaCO ₃	100/400	100/400	100/400	100/400	100/400	100/400	100/400	100/400
Electrical heaters									
Steps	n°	3	3	3	3	3	3	3	3
Power	kW	15,0	15,0	15,0	18,0	18,0	18,0	18,0	24,0
Absorbed current	A	21,7	21,7	21,7	26,0	26,0	26,0	26,0	34,6
Oversized electrical heaters									
Steps	n°	3	3	3	3	3	3	3	3
Power	kW	18,0	18,0	18,0	24,0	24,0	24,0	24,0	27,0
Absorbed current	A	26,0	26,0	26,0	34,6	34,6	34,6	34,6	39,0
Hot water coil									
Heating capacity ⁽³⁾	kW	31,1	31,1	31,1	37,4	37,4	37,4	37,4	48,9
Water flow	m ³ /h	5,43	5,43	5,43	6,5	6,5	6,5	6,5	8,5
Pressure drop (coil + 3 way valve)	kPa	53	53	53	34	34	34	34	48
Coil internal volume	dm ³	5,8	5,8	5,8	7,1	7,1	7,1	7,1	10,45
Condensing water pump									
Nominal flow	l/h	390,0	390,0	390,0	390,0	390,0	390,0	390,0	390,0
Max. flow (prevalence = 0 m)	l/h	500	500	500	500	500	500	500	500
Max. discharge height (flow=0 m ³ /h)	m	5,4	5,4	5,4	5,4	5,4	5,4	5,4	5,4
Condensing water pump + humidifier									
Nominal flow	l/h	600	600	600	600	600	600	600	600
Max. flow (prevalence = 0 m)	l/h	900	900	900	900	900	900	900	900
Max. discharge height (flow=0 m ³ /h)	m	6,0	6,0	6,0	6,0	6,0	6,0	6,0	6,0
Dimensions and weight									
Frame	n°	5	5	5	6	6	6	6	7
Width	mm	1860	1860	1860	2210	2210	2210	2210	2565
Depth	mm	850	850	850	850	850	850	850	850
Height	mm	1980	1980	1980	1980	1980	1980	1980	1980
Weight (Configuration U)	Kg	543	521	544	579	616	618	647	738
Weight (Configuration V)	Kg	549	528	551	586	624	625	654	746
Weight (Configuration D)	Kg	552	531	554	590	627	629	658	750
Weight (Configuration B)	Kg	549	528	551	586	624	625	654	746

Performances are referred to the following conditions:

(1) Ambient temperature 24°C, Relative humidity 50%, Condensing temperature 48°C.

(2) The fans electrical power has to be added to the ambient load.

(3) Water temperature 40/45°C, Ambient temperature 20°C, Relative humidity 50%.

DX.A		762	772	841	862	982	1002	1102	1252
Cooling capacity (Total) ⁽¹⁾ ESP 20 Pa	kW	77	76,8	84	86,8	98,7	98,9	111,9	124,5
Cooling capacity (Sensible) ⁽¹⁾ ESP 20 Pa	kW	76,3	76,2	77,8	78,7	95,6	95,7	101,4	104,9
Tot. absorbed power ⁽²⁾ ESP 20 Pa	kW	20	22	21,9	25,2	26,8	26,4	29,9	34,2
SHR		0,99	0,99	0,93	0,91	0,97	0,97	0,91	0,84
Air flow	m ³ /h	20900	20900	20900	20900	25700	25700	25700	25700
Fan	n	2	2	2	2	3	3	3	3
Max. ESP	Pa	436	436	436	436	458	458	458	458
Unit EER without remote condenser to max. frequency	w/w	3,8	3,5	3,8	3,4	3,7	3,7	3,7	3,6
Maximum absorbed power	Kw	33,2	36,8	36,6	42	47,1	44,6	49,5	57,1
Maximum absorbed current	A	61,2	59,2	73,2	67,6	80,8	84,8	89,6	103,2
starting current	A	154,2	113,2	182,2	126,5	159,8	224,8	199,4	220,6
Power supply	V/ph/Hz	400/3/50+N+PE							
Humidifier									
Steam production (nominal)	kg/h	8	8	8	8	8	8	8	8
Steam production (max.)	kg/h	8	8	8	8	8	8	8	8
Max. absorbed power	kW	6,0	6,0	6,0	6,0	6,0	6,0	6,0	6,0
Max. absorbed current	A	8,7	8,7	8,7	8,7	8,7	8,7	8,7	8,7
Specific conductivity at 20°C (min/max)	µS/cm	300/1250	300/1250	300/1250	300/1250	300/1250	300/1250	300/1250	300/1250
Total hardness (min/max)	mg/l CaCO ₃	100/400	100/400	100/400	100/400	100/400	100/400	100/400	100/400
Electrical heaters									
Steps	n°	3	3	3	3	3	3	3	3
Power	kW	24,0	24,0	24,0	24,0	27,0	27,0	27,0	27,0
Absorbed current	A	34,6	34,6	34,6	34,6	39,0	39,0	39,0	39,0
Oversized electrical heaters									
Steps	n°	3	3	3	3	3	3	3	3
Power	kW	27,0	27,0	27,0	27,0	36,0	36,0	36,0	36,0
Absorbed current	A	39,0	39,0	39,0	39,0	52,0	52,0	52,0	52,0
Hot water coil									
Heating capacity ⁽³⁾	kW	48,9	48,9	48,9	48,9	60,8	60,8	60,8	60,8
Water flow	m ³ /h	8,5	8,5	8,5	8,5	10,6	10,6	10,6	10,6
Pressure drop (coil + 3 way valve)	kPa	48	48	48	48	42	42	42	42
Coil internal volume	dm ³	10,45	10,45	10,45	10,45	12,6	12,6	12,6	12,6
Condensing water pump									
Nominal flow	l/h	390,0	390,0	390,0	390,0	390,0	390,0	390,0	390,0
Max. flow (prevalence = 0 m)	l/h	500	500	500	500	500	500	500	500
Max. discharge height (flow=0 m ³ /h)	m	5,4	5,4	5,4	5,4	5,4	5,4	5,4	5,4
Condensing water pump + humidifier									
Nominal flow	l/h	600	600	600	600	600	600	600	600
Max. flow (prevalence = 0 m)	l/h	900	900	900	900	900	900	900	900
Max. discharge height (flow=0 m ³ /h)	m	6,0	6,0	6,0	6,0	6,0	6,0	6,0	6,0
Dimensions and weight									
Frame	n°	7	7	7	7	8	8	8	8
Width	mm	2565	2565	2565	2565	3100	3100	3100	3100
Depth	mm	850	850	850	850	850	850	850	850
Height	mm	1980	1980	1980	1980	1980	1980	1980	1980
Weight (Configuration U)	Kg	743	780	745	780	937	904	969	972
Weight (Configuration V)	Kg	752	788	753	788	947	914	979	982
Weight (Configuration D)	Kg	756	792	758	792	952	920	984	988
Weight (Configuration B)	Kg	752	788	753	788	947	914	979	982

Performances are referred to the following conditions:

(1) Ambient temperature 24°C, Relative humidity 50%, Condensing temperature 48°C.

(2) The fans electrical power has to be added to the ambient load.

(3) Water temperature 40/45°C, Ambient temperature 20°C, Relative humidity 50%.

3.6 Refrigerant charge

3.6.1 R410A Refrigerant charge (GWP=2088) - unit DXi.A

DXi.A		61	111	121	151	181	201	251	321
Frame		2	2	2	2	3	3	4	4
Circuits	n°	1	1	1	1	1	1	1	1
Refrigerant charge	Kg	3,4	3,4	3,6	4,0	4,0	4,4	6,0	6,8
Equivalent CO ₂ charge	t	7,1	7,1	7,5	8,4	8,4	9,2	12,5	14,2

DXi.A		381	392	472	491	531	532	631	652
Frame		4,5	4,5	4,5	4,5	5	5	6	6
Circuits	n°	1	2	2	1	1	2	1	2
Refrigerant charge	Kg	7,0	9,0	9,6	7,5	8,8	10,2	14,5	16,0
Equivalent CO ₂ charge	t	14,6	18,8	20,0	15,7	18,4	21,3	30,3	33,4

DXi.A		691	742	761	861	931	952	1021	1142
Frame		6	7	7	7	8	8	8	8
Circuits	n°	1	2	1	1	1	2	1	2
Refrigerant charge	Kg	14,5	19,6	19,5	19,5	30,0	30,6	30,2	30,8
Equivalent CO ₂ charge	t	30,3	40,9	40,7	40,7	62,6	63,9	63,1	64,3

3.6.2 R410A Refrigerant charge (GWP=2088) - unit DX.A

DX.A		61	71	91	111	151	181	201	221	251
Frame		1	1	1	2	2	3	3	3	4
Circuits	n°	1	1	1	1	1	1	1	1	1
Refrigerant charge	Kg	3,0	3,1	3,3	3,3	3,5	3,4	3,8	3,6	5,9
Equivalent CO ₂ charge	t	6,3	6,5	6,9	6,9	7,3	7,1	7,9	7,5	12,3

DX.A		232	301	321	322	391	392	431	442	451
Frame		4	4	4	4	4,5	4,5	4,5	4,5	5
Circuits	n°	2	1	1	2	1	2	1	2	1
Refrigerant charge	Kg	6,8	5,9	6,4	6,8	6,2	7,0	6,3	7,2	6,5
Equivalent CO ₂ charge	t	14,2	12,3	13,4	14,2	12,9	14,6	13,2	15,0	13,6

DX.A		472	511	512	531	602	672	742	761
Frame		5	5	5	6	6	6	6	7
Circuits	n°	2	1	2	1	2	2	2	1
Refrigerant charge	Kg	7,4	7,2	8,8	11,7	13,6	13,6	13,6	11,8
Equivalent CO ₂ charge	t	15,4	15,0	18,4	24,4	28,4	28,4	28,4	24,6

DX.A		762	772	841	862	982	1002	1102	1252
Frame		7	7	7	7	8	8	8	8
Circuits	n°	2	2	1	2	2	2	2	2
Refrigerant charge	Kg	14,4	15,2	13,1	15,6	24,0	24,8	24,4	25,0
Equivalent CO ₂ charge	t	30,0	31,7	27,4	32,6	50,1	51,8	50,9	52,2

3.7 Remote condensers technical data

3.7.1 Single circuit remote condenser - Standard version

RCE		091 Kc	111 Kc	211 Kc	311 Kc	421 Kc	571 Kc	671 Kc	991 Kc	1101 Kc	1501 Kc
Heating capacity ⁽¹⁾	kW	9,3	11,1	19,2	29,4	44,2	60,5	66,5	97,4	100,2	150,6
Axial fans											
Quantity	n°	1	1	2	1	4	2	2	3	4	6
Rotation speed	g/min	1450	1450	1450	1300	1400	1300	1300	1300	1300	1300
Air flow	m ³ /h	2600	2400	5200	6620	9600	13250	12500	18760	29440	37530
Total input power	kW	0,14	0,14	0,29	0,68	0,58	1,36	1,36	2,04	2,72	4,08
Total nominal current	A	0,68	0,68	1,36	3,00	2,72	6,00	6,00	9,00	12,00	18,00
Diameter	mm	350	350	350	500	350	500	500	500	500	500
Sound pressure level ⁽²⁾	dB(A)	40	40	43	48	46	51	51	52	53	54
Sound power level ⁽³⁾	dB(A)	71	71	74	79	77	82	82	83	85	86
Dimensions ⁽⁴⁾											
Length - horizontal air flow	mm	882	882	1582	1203	2980	2203	2203	3203	4373	2705
Depth - horizontal air flow	mm	480	480	480	570	480	570	570	570	705	600
Height - horizontal air flow	mm	510	510	510	830	510	830	830	830	1110	1645
Length - vertical air flow	mm	882	882	1582	1219	2980	2219	2219	3219	4393	2705
Depth - vertical air flow	mm	550	550	550	895	550	895	895	895	1110	1717
Height - vertical air flow	mm	811	811	811	1099	811	1099	1099	1099	1230	1070
Weight	kg	25	27	44	67	88	112	120	170	282	250
Battery capacity	dm ³	0,9	1,2	1,5	3,0	4,5	5,9	7,2	11,1	17,7	28,2
Input/output connections	mm/mm	16/16	16/16	16/16	22/22	28/28	28/28	28/28	42/35	42/35	54/42
Power supply	V/ph/Hz	230/1/50+T									

3.7.2 Single circuit remote condenser - Low noise version

RCE-S		151 Kc	261 Kc	351 Kc	501 Kc	571 Kc	651 Kc	1001 Kc	1101 Kc	1301 Kc	
Heating capacity ⁽¹⁾	kW	15,8	22,8	30,9	46,2	57,1	66	78,4	108,7	140,1	
Axial fans											
Quantity	n°	1	1	2	2	3	3	4	6	6	
Rotation speed	g/min	665	865	665	865	865	865	865	665	865	
Air flow	m ³ /h	3590	4040	7180	8080	14100	12970	19930	20370	28200	
Total input power	kW	0,13	0,22	0,26	0,44	0,66	0,66	0,88	0,78	1,32	
Total nominal current	A	0,59	0,97	1,18	1,94	2,91	2,91	3,88	3,54	5,82	
Diameter	mm	500	500	500	500	500	500	500	500	500	
Sound pressure level ⁽²⁾	dB(A)	30	37	33	40	41	41	42	37	44	
Sound power level ⁽³⁾	dB(A)	61	68	64	71	72	72	74	69	76	
Dimensions ⁽⁴⁾											
Length - horizontal air flow	mm	1203	1203	2203	2203	3203	3203	4373	3393	3393	
Depth - horizontal air flow	mm	570	570	570	570	570	570	705	990	990	
Height - horizontal air flow	mm	830	830	830	830	830	830	1110	2110	2110	
Length - vertical air flow	mm	1219	1219	2219	2219	3219	3219	4393	3393	3393	
Depth - vertical air flow	mm	895	895	895	895	895	895	1110	2110	2110	
Height - vertical air flow	mm	1099	1099	1099	1099	1099	1099	1230	1230	1230	
Weight	kg	62	71	104	120	146	157	282	425	425	
Battery capacity	dm ³	1,9	4,2	3,7	7,2	5,6	8,2	17,7	41,8	41,8	
Input/output connections	mm/mm	16/16	28/28	28/28	28/28	28/28	35/28	42/35	54/42	54/42	
Power supply	V/ph/Hz	230/1/50+T									

(1) Performances are referred to the following conditions: Ambient temperature 35°C, Condensing temperature 50°C.

(2) Sound pressure level measured at 10 mt from the unit in free field conditions according to ISO 3744.

(3) Sound power level according to ISO 3744.

(4) Including support brackets.

3.7.3 Double circuit remote condenser - Standard version

RCE		302 Kc	482 Kc	602 Kc	752 Kc	862 Kc	1052 Kc	1152 Kc	1252 Kc	1602 Kc	1702 Kc
Heating capacity ⁽¹⁾	kW	29,4	44,2	60,5	66,5	87,8	97,4	100,2	124,4	150,6	170,2
Axial fans											
Quantity	n°	1	4	2	2	3	3	4	4	6	6
Rotation speed	g/min	1300	1400	1300	1300	1300	1300	1300	1300	1300	1300
Air flow	m³/h	6620	9600	13240	12510	19870	18770	29440	27970	37540	35330
Total input power	kW	0,68	0,58	1,36	1,36	2,04	2,04	2,72	2,72	4,08	4,08
Total nominal current	A	3	2,72	6	6	9	9	12	12	18	18
Diameter	mm	500	350	500	500	500	500	500	500	500	500
Sound pressure level ⁽²⁾	dB(A)	48	46	51	51	52	52	53	53	54	54
Sound power level ⁽³⁾	dB(A)	79	77	82	82	83	83	85	85	86	86
Dimensions ⁽⁴⁾											
Length - horizontal air flow	mm	1203	2980	2203	2203	3203	3203	4373	4373	2705	2705
Depth - horizontal air flow	mm	570	480	570	570	570	570	705	705	600	600
Height - horizontal air flow	mm	830	510	830	830	830	830	1110	1110	1645	1645
Length - vertical air flow	mm	1219	2980	2219	2219	3219	3219	4393	4393	2705	2705
Depth - vertical air flow	mm	895	550	895	895	895	895	1110	1110	1717	1717
Height - vertical air flow	mm	1099	811	1099	1099	1099	1099	1230	1230	1070	1070
Weight	kg	67	88	112	120	157	170	282	312	250	274
Battery capacity	dm³	3,0	4,5	5,9	7,2	8,2	11,1	17,7	26,6	28,2	35,9
Input/output connections	mm/mm	22/22	28/28	28/28	28/28	35/28	42/35	42/35	54/42	54/42	54/42
Power supply	V/ph/Hz	230/1/50+T									

3.7.4 Double circuit remote condenser - Low noise version

RCE-S		382 Kc	482 Kc	602 Kc	752 Kc	862 Kc	1252 Kc	1602 Kc	1702 Kc
Heating capacity ⁽¹⁾	kW	37,1	46,2	57,1	68,4	93,3	114,3	116,6	157,8
Axial fans									
Quantity	n°	2	2	3	3	4	6	5	8
Rotation speed	g/min	865	865	865	865	865	865	865	865
Air flow	m³/h	9400	8084	14100	12120	18800	24810	23500	39850
Total input power	kW	0,44	0,44	0,66	0,66	0,88	1,32	1,1	1,76
Total nominal current	A	1,94	1,94	2,91	2,91	3,88	5,82	4,85	7,76
Diameter	mm	500	500	500	500	500	500	500	500
Sound pressure level ⁽²⁾	dB(A)	40	40	41	41	42	44	43	45
Sound power level ⁽³⁾	dB(A)	71	71	72	72	74	76	75	77
Dimensions ⁽⁴⁾									
Length - horizontal air flow	mm	2203	2203	3203	3203	4373	2705	5373	4393
Depth - horizontal air flow	mm	570	570	570	570	705	600	705	2110
Height - horizontal air flow	mm	830	830	830	830	1110	1645	1100	990
Length - vertical air flow	mm	2219	2219	3219	3219	4393	2705	5393	4393
Depth - vertical air flow	mm	895	895	895	895	1110	1717	1110	2110
Height - vertical air flow	mm	1099	1099	1099	1099	1230	1070	1230	1230
Weight	kg	104	120	146	170	312	250	370	490
Battery capacity	dm³	4,0	7,2	5,6	11,1	26,6	28,2	32,4	37,6
Input/output connections	mm/mm	28/28	28/28	28/28	42/35	54/42	54/42	54/42	54/42
Power supply	V/ph/Hz	230/1/50+T							

(1) Performances are referred to the following conditions: Ambient temperature 35°C, Condensing temperature 50°C.

(2) Sound pressure level measured at 10 mt from the unit in free field conditions according to ISO 3744.

(3) Sound power level according to ISO 3744.

(4) Including support brackets.

3.8 Matching between indoor unit and remote condenser

3.8.1 DX.A - Standard remote condenser

	Single circuit	Double circuit	Oversize - Single circuit	Oversize - Double circuit
DX.A 61	RCE 091 Kc	--	RCE 091 Kc	--
DX.A 71	RCE 091 Kc	--	RCE 111 Kc	--
DX.A 91	RCE 111 Kc	--	RCE 211 Kc	--
DX.A 111	RCE 111 Kc	--	RCE 211 Kc	--
DX.A 151	RCE 211 Kc	--	RCE 311 Kc	--
DX.A 181	RCE 211 Kc	--	RCE 311 Kc	--
DX.A 201	RCE 211 Kc	--	RCE 311 Kc	--
DX.A 221	RCE 311 Kc	--	RCE 421 Kc	--
DX.A 251	RCE 311 Kc	--	RCE 421 Kc	--
DX.A 232	2 x RCE 111 Kc	RCE 302 Kc	2 x RCE 211 Kc	RCE 482 Kc
DX.A 301	RCE 311 Kc	--	RCE 421 Kc	--
DX.A 321	RCE 421 Kc	--	RCE 421 Kc	--
DX.A 322	2 x RCE 211 Kc	RCE 302 Kc	2 x RCE 311 Kc	RCE 482 Kc
DX.A 391	RCE 421 Kc	--	RCE 571 Kc	--
DX.A 392	2 x RCE 211 Kc	RCE 482 Kc	2 x RCE 311 Kc	RCE 602 Kc
DX.A 431	RCE 421 Kc	--	RCE 571 Kc	--
DX.A 442	2 x RCE 311 Kc	RCE 482 Kc	2 x RCE 421 Kc	RCE 602 Kc
DX.A 451	RCE 421 Kc	--	RCE 571 Kc	--
DX.A 472	2 x RCE 311 Kc	RCE 482 Kc	2 x RCE 421 Kc	RCE 752 Kc
DX.A 511	RCE 571 Kc	--	RCE 671 Kc	--
DX.A 512	2 x RCE 311 Kc	RCE 602 Kc	2 x RCE 421 Kc	RCE 752 Kc
DX.A 531	RCE 571 Kc	--	RCE 991 Kc	--
DX.A 602	2 x RCE 311 Kc	RCE 602 Kc	2 x RCE 421 Kc	RCE 862 Kc
DX.A 672	2 x RCE 421 Kc	RCE 602 Kc	2 x RCE 571 Kc	RCE 862 Kc
DX.A 742	2 x RCE 421 Kc	RCE 752 Kc	2 x RCE 571 Kc	RCE 1052 Kc
DX.A 761	RCE 671 Kc	--	RCE 991 Kc	--
DX.A 762	2 x RCE 421 Kc	RCE 862 Kc	2 x RCE 571 Kc	RCE 1052 Kc
DX.A 772	2 x RCE 421 Kc	RCE 862 Kc	2 x RCE 571 Kc	RCE 1152 Kc
DX.A 841	RCE 991 Kc	--	RCE 1101 Kc	--
DX.A 862	2 x RCE 421 Kc	RCE 862 Kc	2 x RCE 571 Kc	RCE 1252 Kc
DX.A 982	2 x RCE 421 Kc	RCE 1052 Kc	2 x RCE 671 Kc	RCE 1602 Kc
DX.A 1002	2 x RCE 421 Kc	RCE 1052 Kc	2 x RCE 671 Kc	RCE 1602 Kc
DX.A 1102	2 x RCE 571 Kc	RCE 1252 Kc	2 x RCE 991 Kc	RCE 1602 Kc
DX.A 1252	2 x RCE 571 Kc	RCE 1252 Kc	2 x RCE 991 Kc	RCE 1702 Kc

3.8.2 DX.A - Remote condenser low noise version

	Single circuit	Double circuit	Overize - Single circuit	Overize - Double circuit
DX.A 61	RCE-S 151 Kc	--	RCE-S 151 Kc	--
DX.A 71	RCE-S 151 Kc	--	RCE-S 151 Kc	--
DX.A 91	RCE-S 151 Kc	--	RCE-S 151 Kc	--
DX.A 111	RCE-S 151 Kc	--	RCE-S 151 Kc	--
DX.A 151	RCE-S 151 Kc	--	RCE-S 261 Kc	--
DX.A 181	RCE-S 261 Kc	--	RCE-S 351 Kc	--
DX.A 201	RCE-S 261 Kc	--	RCE-S 351 Kc	--
DX.A 221	RCE-S 261 Kc	--	RCE-S 501 Kc	--
DX.A 251	RCE-S 261 Kc	--	RCE-S 501 Kc	--
DX.A 232	2 x RCE-S 151 Kc	RCE-S 382 Kc	2 x RCE-S 151 Kc	RCE-S 482 Kc
DX.A 301	RCE-S 351 Kc	--	RCE-S 501 Kc	--
DX.A 321	RCE-S 351 Kc	--	RCE-S 501 Kc	--
DX.A 322	2 x RCE-S 151 Kc	RCE-S 382 Kc	2 x RCE-S 261 Kc	RCE-S 482 Kc
DX.A 391	RCE-S 501 Kc	--	RCE-S 571 Kc	--
DX.A 392	2 x RCE-S 261 Kc	RCE-S 382 Kc	2 x RCE-S 351 Kc	RCE-S 602 Kc
DX.A 431	RCE-S 501 Kc	--	RCE-S 501 Kc	--
DX.A 442	2 x RCE-S 261 Kc	RCE-S 482 Kc	2 x RCE-S 351 Kc	RCE-S 752 Kc
DX.A 451	RCE-S 501 Kc	--	RCE-S 651 Kc	--
DX.A 472	2 x RCE-S 261 Kc	RCE-S 482 Kc	2 x RCE-S 501 Kc	RCE-S 752 Kc
DX.A 511	RCE-S 501 Kc	--	RCE-S 651 Kc	--
DX.A 512	2 x RCE-S 261 Kc	RCE-S 482 Kc	2 x RCE-S 501 Kc	RCE-S 752 Kc
DX.A 531	RCE-S 571 Kc	--	RCE-S 1001 Kc	--
DX.A 602	2 x RCE-S 351 Kc	RCE-S 602 Kc	2 x RCE-S 501 Kc	RCE-S 862 Kc
DX.A 672	2 x RCE-S 351 Kc	RCE-S 752 Kc	2 x RCE-S 501 Kc	RCE-S 862 Kc
DX.A 742	2 x RCE-S 501 Kc	RCE-S 752 Kc	2 x RCE-S 571 Kc	RCE-S 1252 Kc
DX.A 761	RCE-S 1001 Kc	--	RCE-S 1001 Kc	--
DX.A 762	2 x RCE-S 501 Kc	RCE-S 752 Kc	2 x RCE-S 571 Kc	RCE-S 1252 Kc
DX.A 772	2 x RCE-S 501 Kc	RCE-S 862 Kc	2 x RCE-S 571 Kc	RCE-S 1252 Kc
DX.A 841	RCE-S 1001 Kc	--	RCE-S 1001 Kc	--
DX.A 862	2 x RCE-S 501 Kc	RCE-S 1052 Kc	2 x RCE-S 651 Kc	RCE-S 1252 Kc
DX.A 982	2 x RCE-S 501 Kc	RCE-S 1052 Kc	2 x RCE-S 651 Kc	RCE-S 1602 Kc
DX.A 1002	2 x RCE-S 501 Kc	RCE-S 1052 Kc	2 x RCE-S 651 Kc	RCE-S 1602 Kc
DX.A 1102	2 x RCE-S 571 Kc	RCE-S 1252 Kc	2 x RCE-S 1001 Kc	RCE-S 1702 Kc
DX.A 1252	2 x RCE-S 571 Kc	RCE-S 1252 Kc	2 x RCE-S 1101 Kc	RCE-S 1702 Kc

3.8.3 DXi.A - Standard remote condenser

	Single circuit	Double circuit	Oversize - Single circuit	Oversize - Double circuit
DXi.A 61	RCE 091 Kc	--	RCE 111 Kc	--
DXi.A 111	RCE 111 Kc	--	RCE 211 Kc	--
DXi.A 121	RCE 111 Kc	--	RCE 211 Kc	--
DXi.A 151	RCE 211 Kc	--	RCE 311 Kc	--
DXi.A 181	RCE 211 Kc	--	RCE 311 Kc	--
DXi.A 201	RCE 211 Kc	--	RCE 311 Kc	--
DXi.A 251	RCE 311 Kc	--	RCE 421 Kc	--
DXi.A 321	RCE 421 Kc	--	RCE 571 Kc	--
DXi.A 381	RCE 421 Kc	--	RCE 571 Kc	--
DXi.A 392	2 x RCE 211 Kc	RCE 482 Kc	2 x RCE 311 Kc	RCE 602 Kc
DXi.A 472	2 x RCE 311 Kc	RCE 482 Kc	2 x RCE 421 Kc	RCE 752 Kc
DXi.A 491	RCE 571 Kc	--	RCE 991 Kc	--
DXi.A 531	RCE 571 Kc	--	RCE 991 Kc	--
DXi.A 532	2 x RCE 311 Kc	RCE 602 Kc	2 x RCE 421 Kc	RCE 862 Kc
DXi.A 631	RCE 571 Kc	--	RCE 991 Kc	--
DXi.A 652	2 x RCE 421 Kc	RCE 702 Kc	2 x RCE 571 Kc	RCE 1052 Kc
DXi.A 691	RCE 671 Kc	--	RCE 991 Kc	--
DXi.A 742	2 x RCE 421 Kc	RCE 862 Kc	2 x RCE 571 Kc	RCE 1052 Kc
DXi.A 761	RCE 991 Kc	--	RCE 1101 Kc	--
DXi.A 861	RCE 991 Kc	--	RCE 1501 Kc	--
DXi.A 931	RCE 991 Kc	--	RCE 1501 Kc	--
DXi.A 952	2 x RCE 421 Kc	RCE 1052 Kc	2 x RCE 671 Kc	RCE 1602 Kc
DXi.A 1021	RCE 991 Kc	--	RCE 1501 Kc	--
DXi.A 1142	2 x RCE 571 Kc	RCE 1252 Kc	2 x RCE 991 Kc	RCE 1602 Kc

3.8.4 DXi.A - Remote condenser low noise version

	Single circuit	Double circuit	Oversize - Single circuit	Oversize - Double circuit
DXi.A 61	RCE-S 151 Kc	--	RCE-S 151 Kc	--
DXi.A 111	RCE-S 151 Kc	--	RCE-S 151 Kc	--
DXi.A 121	RCE-S 151 Kc	--	RCE-S 261 Kc	--
DXi.A 151	RCE-S 261 Kc	--	RCE-S 261 Kc	--
DXi.A 181	RCE-S 261 Kc	--	RCE-S 351 Kc	--
DXi.A 201	RCE-S 261 Kc	--	RCE-S 351 Kc	--
DXi.A 251	RCE-S 261 Kc	--	RCE-S 501 Kc	--
DXi.A 321	RCE-S 501 Kc	--	RCE-S 571 Kc	--
DXi.A 381	RCE-S 501 Kc	--	RCE-S 571 Kc	--
DXi.A 392	2 x RCE-S 261 Kc	RCE-S 382 Kc	2 x RCE-S 351 Kc	RCE-S 602 Kc
DXi.A 472	2 x RCE-S 261 Kc	RCE-S 482 Kc	2 x RCE-S 501 Kc	RCE-S 752 Kc
DXi.A 491	RCE-S 571 Kc	--	RCE-S 1001 Kc	--
DXi.A 531	RCE-S 571 Kc	--	RCE-S 1001 Kc	--
DXi.A 532	2 x RCE-S 351 Kc	RCE-S 602 Kc	2 x RCE-S 501 Kc	RCE-S 752 Kc
DXi.A 631	RCE-S 651 Kc	--	RCE-S 1101 Kc	--
DXi.A 652	2 x RCE-S 501 Kc	RCE-S 752 Kc	2 x RCE-S 571 Kc	RCE-S 1252 Kc
DXi.A 691	RCE-S 651 Kc	--	RCE-S 1101 Kc	--
DXi.A 742	2 x RCE-S 501 Kc	RCE-S 862 Kc	2 x RCE-S 571 Kc	RCE-S 1252 Kc
DXi.A 761	RCE-S 1001 Kc	--	RCE-S 1101 Kc	--
DXi.A 861	RCE-S 1001 Kc	--	RCE-S 1301 Kc	--
DXi.A 931	RCE-S 1101 Kc	--	RCE-S 1301 Kc	--
DXi.A 952	2 x RCE-S 501 Kc	RCE-S 1052 Kc	2 x RCE-S 651 Kc	RCE-S 1602 Kc
DXi.A 1021	RCE-S 1101 Kc	--	RCE-S 1301 Kc	--
DXi.A 1142	2 x RCE-S 571 Kc	RCE-S 1252 Kc	2 x RCE-S 1001 Kc	RCE-S 1702 Kc

3.5 Operation limits



The unit is designed and built for air conditioning technological environments and must be used exclusively for this purpose within its characteristics. All the other uses are not allowed and dissolve the Manufacturer from any liability for damages caused to the peoples, animals, environment or things.



In case of different uses from the overmentioned please contact the Manufacturer.



The minimum temperature of the ambient to be cooled has to be of 18°C.
The maximum temperature of the ambient to be cooled has to be of 35°C.



The units in standard configuration are not suitable for marine installations.

Operation limits		
Indoor air conditions	Temperature	From 20°C to 35°C
	Relative humidity	From 20% to 60%
Hot water circuit	Water inlet temperature	Max. 85°C
	Water pressure	Max. 8.5 bar
Storage conditions	Temperature	From -20°C to 50°C
	Specific humidity	Maximum relative humidity percentage accepted is 90% to prevent condensation on surfaces
Power supply tolerances		V ± 10%, Hz ± 2



Lower heat load will not ensure precise temperature and humidity control than causing frequent compressor start & stop.
The room heat load cannot be less than 20% of the sensible cooling capacity of the precision air conditioner.

3.5.1 Outdoor temperature limits



Exceeding the lower winter limits, can cause the temporary block of the compressor (s) through the low pressure transducer. The reset of normal operating conditions can be done manually only through unit electronic control.

From -20°C to 42°C	From 15°C to 36°C	Up to 48°C
Standard remote condenser + fan speed controller	Standard remote condenser	Remote condenser special version + fan speed controller



Upper limit: This limit is determined by the size of matched external condenser. To exceed this limit (even caused by insufficient maintenance of the unit) might cause the complete block of compressor trough the activation of high-pressure switch.



To ensure a correct unit functionality, performances and longer life cycle, indoor unit must be connected to a remote condenser approved by the Company. Warranty conditions will immediately cease their use if the indoor unit would be found connected to an equipment not approved by the Company.

3.6 Sound data DXi.A



Here below are the sound data for units with canalized discharge and supply (except U version); the data refer to standard ambient conditions and to design prevalence/air flow (20 Pa).

DXi.A - Configuration D									Lw	Lp1	Lp10
Mod.	63	125	250	500	1K	2K	4K	8K	dB(A)	dB(A)	dB(A)
	dB(A)	dB(A)	dB(A)	dB(A)	dB(A)	dB(A)	dB(A)	dB(A)			
61	44	55	62	66	71	72	67	59	76	56	45
111	41	52	62	67	73	73	69	63	77	57	46
121	41	52	62	67	73	73	69	63	77	57	46
151	41	52	62	67	73	73	69	63	77	57	46
181	45	62	65	70	73	73	71	62	78	58	47
201	46	63	66	71	74	74	72	63	79	59	48
251	46	63	66	73	75	72	70	62	79	59	48
321	48	65	68	74	76	75	72	64	81	61	50
381	41	63	67	75	76	75	74	64	81	61	50
392	40	63	67	73	74	75	73	63	80	60	49
472	42	64	68	76	77	76	74	65	82	62	51
491	43	64	68	76	78	77	74	65	83	63	52
531	51	71	72	76	78	77	75	67	83	62	52
532	50	70	72	76	77	76	74	67	82	61	51
631	66	72	75	79	80	80	76	68	85	64	54
652	66	72	75	79	80	80	76	68	85	64	54
691	66	72	75	79	80	80	76	68	85	64	54
742	57	70	72	79	79	80	77	68	85	64	54
761	57	70	72	79	79	80	77	68	85	64	54
861	56	69	71	78	78	79	76	67	84	63	53
931	57	70	73	79	78	78	77	66	84	63	53
952	57	70	73	79	78	78	77	66	84	63	53
1021	57	70	73	79	78	78	77	66	84	63	53
1142	58	71	73	79	79	79	78	67	85	64	54

Lw: Sound power level according to ISO 3744.

Lp1: Sound pressure level measured at 2 mt from the unit in free field conditions according to ISO 3744.

Lp10: Sound pressure level measured at 10 mt from the unit in free field conditions according to ISO 3744.

DXi.A - Configuration V and B									Lw	Lp1	Lp10
Mod.	63	125	250	500	1K	2K	4K	8K	dB(A)	dB(A)	dB(A)
	dB(A)	dB(A)	dB(A)	dB(A)	dB(A)	dB(A)	dB(A)	dB(A)			
61	41	52	62	67	73	73	69	63	77	57	46
111	42	51	62	67	73	73	70	63	78	58	47
121	42	51	62	67	73	73	70	63	78	58	47
151	42	51	62	67	73	73	70	63	78	58	47
181	46	63	66	71	74	74	72	63	79	59	48
201	47	64	67	72	75	75	73	64	80	60	49
251	47	64	67	74	76	74	71	63	80	60	49
321	50	70	70	76	78	75	73	67	82	62	51
381	42	64	68	76	77	76	74	65	82	62	51
392	41	63	67	75	76	75	74	64	81	61	50
472	43	64	68	76	78	77	74	65	83	63	52
491	47	70	71	79	80	79	77	69	84	64	53
531	51	71	72	77	79	78	75	67	84	63	53
532	51	71	72	76	78	77	75	67	83	62	52
631	66	72	75	79	81	81	76	68	86	65	55
652	66	72	75	79	81	81	76	68	86	65	55
691	66	72	75	79	81	81	76	68	86	65	55
742	59	71	73	81	81	79	78	69	86	65	55
761	59	71	73	81	81	79	78	69	86	65	55
861	57	70	72	79	79	80	77	68	85	64	54
931	58	71	73	79	79	79	78	67	85	64	54
952	58	71	73	79	79	79	78	67	85	64	54
1021	58	71	73	79	79	79	78	67	85	64	54
1142	59	71	73	80	80	81	78	69	86	65	55

DXi.A - Configuration U											
Mod.	63	125	250	500	1K	2K	4K	8K	Lw	Lp1	Lp10
	dB(A)	dB(A)	dB(A)	dB(A)	dB(A)	dB(A)	dB(A)	dB(A)	dB(A)	dB(A)	dB(A)
61	42	51	62	67	73	73	70	63	78	58	47
111	45	57	65	69	74	75	71	63	79	59	48
121	45	57	65	69	74	75	71	63	79	59	48
151	45	57	65	69	74	75	71	63	79	59	48
181	47	64	67	72	75	75	73	64	80	60	49
201	48	64	68	73	76	76	74	65	81	61	50
251	48	65	68	74	76	75	72	64	81	61	50
321	50	70	71	76	78	76	74	67	83	63	52
381	43	64	68	76	78	77	74	65	83	63	52
392	42	64	68	76	77	76	74	65	82	62	51
472	47	70	71	79	80	79	77	69	84	64	53
491	48	67	70	78	80	80	77	67	85	65	54
531	58	73	73	78	80	78	77	70	85	64	54
532	51	71	72	77	79	78	75	67	84	63	53
631	66	72	75	80	83	81	77	68	87	66	56
652	66	72	75	80	83	81	77	68	87	66	56
691	66	72	75	80	83	81	77	68	87	66	56
742	61	72	74	80	82	82	77	69	87	66	56
761	61	72	74	80	82	82	77	69	87	66	56
861	59	71	73	81	81	79	78	69	86	65	55
931	59	71	73	80	80	81	78	69	86	65	55
952	59	71	73	80	80	81	78	69	86	65	55
1021	59	71	73	80	80	81	78	69	86	65	55
1142	60	71	74	80	82	81	77	69	87	66	56

Lw: Sound power level according to ISO 3744.

Lp1: Sound pressure level measured at 2 mt from the unit in free field conditions according to ISO 3744.

Lp10: Sound pressure level measured at 10 mt from the unit in free field conditions according to ISO 3744.

3.7 Sound data DX.A



Here below are the sound data for units with canalized discharge and supply (except U version); the data refer to standard ambient conditions and to design prevalence/air flow (20 Pa).

DX.A - Version D									Lw	Lp1	Lp10
Mod.	63	125	250	500	1K	2K	4K	8K	dB(A)	dB(A)	dB(A)
	dB(A)	dB(A)	dB(A)	dB(A)	dB(A)	dB(A)	dB(A)	dB(A)			
61	36	52	57	62	68	68	64	56	72	52	41
71	36	52	57	62	68	68	64	56	72	52	41
91	38	52	58	63	69	69	65	57	73	53	42
111	39	52	59	64	70	70	67	59	75	55	44
151	44	55	62	66	71	72	67	59	76	56	45
181	38	55	59	64	67	67	63	52	72	52	41
201	39	57	60	65	69	68	64	54	73	53	42
221	39	57	60	65	69	68	64	54	73	53	42
232	39	55	60	66	68	67	63	53	73	53	42
251	39	55	60	66	68	67	63	53	73	53	42
301	42	57	62	68	70	69	66	56	75	55	44
321	42	57	62	68	70	69	66	56	75	55	44
322	40	57	61	68	69	69	65	56	74	54	43
391	39	58	63	71	72	71	68	58	77	57	46
392	39	56	62	70	71	70	66	56	76	56	45
431	39	58	63	71	72	71	68	58	77	57	46
442	39	56	62	70	71	70	66	56	76	56	45
451	43	62	64	70	72	70	67	58	77	56	46
472	42	60	63	69	71	70	66	57	76	55	45
511	43	62	64	70	72	70	67	58	77	56	46
512	42	60	63	69	71	70	66	57	76	55	45
531	45	65	66	72	74	72	70	61	79	58	48
602	45	65	66	72	74	72	70	61	79	58	48
672	45	65	66	72	74	72	70	61	79	58	48
742	45	63	66	72	74	74	71	62	80	59	49
761	40	61	65	73	74	73	70	61	79	58	48
762	40	61	65	73	74	73	70	61	79	58	48
772	39	58	63	71	72	71	68	58	77	56	46
841	40	61	65	73	74	73	70	61	79	58	48
862	39	58	63	71	72	71	68	58	77	56	46
982	39	58	63	71	72	71	68	58	77	56	46
1002	40	62	66	74	75	74	71	62	80	59	49
1102	40	62	66	74	75	74	71	62	80	59	49
1252	40	62	66	74	75	74	71	62	80	59	49

Lw: Sound power level according to ISO 3744.

Lp1: Sound pressure level measured at 2 mt from the unit in free field conditions according to ISO 3744.

Lp10: Sound pressure level measured at 10 mt from the unit in free field conditions according to ISO 3744.

DX.A - Versione									Lw	Lp1	Lp10
Mod.	63	125	250	500	1K	2K	4K	8K	dB(A)	dB(A)	dB(A)
	dB(A)	dB(A)	dB(A)	dB(A)	dB(A)	dB(A)	dB(A)	dB(A)			
61	38	52	58	63	69	69	65	57	73	53	42
71	38	52	58	63	69	69	65	57	73	53	42
91	38	52	58	64	70	70	66	58	74	54	43
111	44	55	62	66	71	72	67	59	76	56	45
151	41	52	62	67	73	73	69	63	77	57	46
181	39	57	60	65	69	68	64	54	73	53	42
201	38	58	61	66	70	68	65	55	74	54	43
221	38	58	61	66	70	68	65	55	74	54	43
232	40	57	61	67	69	68	64	55	74	54	43
251	40	57	61	67	69	68	64	55	74	54	43
301	42	60	63	69	71	70	66	57	76	56	45
321	42	60	63	69	71	70	66	57	76	56	45
322	42	57	62	68	70	69	66	56	75	55	44
391	39	59	64	72	73	72	68	59	78	58	47
392	39	58	63	71	72	71	68	58	77	57	46
431	39	59	64	72	73	72	68	59	78	58	47
442	39	58	63	71	72	71	68	58	77	57	46
451	44	65	65	71	73	72	69	60	78	57	47
472	43	62	64	70	72	70	67	58	77	56	46
511	44	65	65	71	73	72	69	60	78	57	47
512	43	62	64	70	72	70	67	58	77	56	46
531	45	63	66	72	74	74	71	62	80	59	49
602	45	63	66	72	74	74	71	62	80	59	49
672	45	63	66	72	74	74	71	62	80	59	49
742	48	65	68	74	76	75	72	64	81	60	50
761	40	62	66	74	75	74	71	62	80	59	49
762	40	62	66	74	75	74	71	62	80	59	49
772	39	59	64	72	73	72	68	59	78	57	47
841	40	62	66	74	75	74	71	62	80	59	49
862	39	59	64	72	73	72	68	59	78	57	47
982	39	59	64	72	73	72	68	59	78	57	47
1002	42	63	67	75	76	75	73	63	81	60	50
1102	42	63	67	75	76	75	73	63	81	60	50
1252	42	63	67	75	76	75	73	63	81	60	50

Lw: Sound power level according to ISO 3744.

Lp1: Sound pressure level measured at 2 mt from the unit in free field conditions according to ISO 3744.

Lp10: Sound pressure level measured at 10 mt from the unit in free field conditions according to ISO 3744.

DX.A - Versione											
Mod.	63	125	250	500	1K	2K	4K	8K	Lw	Lp1	Lp10
	dB(A)	dB(A)	dB(A)	dB(A)	dB(A)	dB(A)	dB(A)	dB(A)	dB(A)	dB(A)	dB(A)
61	38	52	58	64	70	70	66	58	74	54	43
71	38	52	58	64	70	70	66	58	74	54	43
91	39	52	59	64	70	70	67	59	75	55	44
111	41	52	62	67	73	73	69	63	77	57	46
151	42	51	62	67	73	73	70	63	78	58	47
181	38	58	61	66	70	68	65	55	74	54	43
201	40	58	61	67	70	69	66	57	75	55	44
221	40	58	61	67	70	69	66	57	75	55	44
251	42	57	62	68	70	69	66	56	75	55	44
232	42	57	62	68	70	69	66	56	75	55	44
301	43	62	64	70	72	70	67	58	77	57	46
321	43	62	64	70	72	70	67	58	77	57	46
322	42	60	63	69	71	70	66	57	76	56	45
391	40	61	65	73	74	73	70	61	79	59	48
392	39	59	64	72	73	72	68	59	78	58	47
431	40	61	65	73	74	73	70	61	79	59	48
442	39	59	64	72	73	72	68	59	78	58	47
451	45	65	66	72	74	72	70	61	79	58	48
472	44	65	65	71	73	72	69	60	78	57	47
511	45	65	66	72	74	72	70	61	79	58	48
512	44	65	65	71	73	72	69	60	78	57	47
531	48	65	68	74	76	75	72	64	81	60	50
602	48	65	68	74	76	75	72	64	81	60	50
672	48	65	68	74	76	75	72	64	81	60	50
742	50	68	70	75	77	76	73	66	82	61	51
761	42	63	67	75	76	75	73	63	81	60	50
762	42	63	67	75	76	75	73	63	81	60	50
772	40	61	65	73	74	73	70	61	79	58	48
841	42	63	67	75	76	75	73	63	81	60	50
862	40	61	65	73	74	73	70	61	79	58	48
982	40	61	65	73	74	73	70	61	79	58	48
1002	42	64	68	76	77	76	74	65	82	61	51
1102	42	64	68	76	77	76	74	65	82	61	51
1252	42	64	68	76	77	76	74	65	82	61	51

Lw: Sound power level according to ISO 3744.

Lp1: Sound pressure level measured at 2 mt from the unit in free field conditions according to ISO 3744.

Lp10: Sound pressure level measured at 10 mt from the unit in free field conditions according to ISO 3744.

4. INSTALLATION

4.1 General advices and symbols use



Before to operate any intervention the technicians has to know perfectly the unit functioning and all its components, also for having read the present Manual.



The maintenance operations has to be performed by well trained technicians in compliance with national legislation in the country of destination.



The unit installation and maintenance has to be performed following the regulation and norms in force.



Do not approach or insert any object into moving parts.

4.2. Workers health and safety



The operator's workplace must be kept clean, tidy and free of objects that mas restrict free movement; the workplace must be adequately lit for the intended operations. Inadequate or excessive lighting can pose risks.



Ensure that excellent ventilation of the work rooms is always guaranteed and that the extraction systems are always functional, in excellent condition and in compliance with the provisions of the law.

4.3 Individual protection devices



The technicians in charge for unit installation and maintenance has to wear mandatory, following the laws in force, the below mentioned protection devices.



Protection shoes.



Eyes's protections.



Protection gloves.



Respiratory protection.



Ears protections.

4.4 Receipt and inspection

During the installation or any intervention it is mandatory to follow strictly any norms reported on the present Manual, to follow the onboard indications and apply every precaution in order to avoid any dangerous situation. At the unit receipt it is necessary to make a visual inspection; the unit left the Manufacturer in perfect conditions, damages occurs during transport has to be immediately disputed with the carrier noticing on the delivery sheet before signing in. The Manufacturer has to be informed about the damages within days from receiving of the unit. The unit owner must to complete a written report in the event of significant damage.

Before to accept the delivery check carefully:

- The unit has not be damaged during the transport;;
- The delivered unit corresponds to the ones indicated on the transport document.

If any damage or fault occurs:

- Note immediately the damage on delivery document;
- Inform Manufacturer or supplier, within 8 days from receipt, about the damage type; reports after 8 days from receipt are not valid;
- In case of significant damage, complete a written report.

4.5 Storage and transport

If it was necessary to storage the unit, ensure to leave it in a closed and dry place; if the unit is already unpacked please follow the hereafter indications to avoid a possible corrosion, damage or deterioration:

- Be sure about every opening is well plugged or sealed;
- Dot use steam or aggressive detergents to clean the unit;
- Take out the control cabinet keys (if presents) and entrust them to the site manager.



The unit can be stocked to temperature between -10° to +65°C; during the stops it is recommended to be sure about those temperatures in order to avoid refrigerant's leak from the safety valves.

The transport has to be done by authorized carriers and the truck characteristics must be such by to not damage the units during the load and during the transport. Il trasporto If the road are bumpy, the truck must have suspension suitable to protect the unit from any damage.

4.6 Unpacking



The packaging could create risks for the operators

Is suggest to leave the packaged unit during the handling and remove it just before the installation. Be careful to remove the packaging in order to avoid unit damages and operators dangers.

The materials which compose the packaging could be from different nature (wood, nylon, cardboard, etc.)



The packaging materials has to be separately preserved and delivered for disposal or eventually for recycle to the responsible companies in order to reduce the environmental impact.
Keep out the material of reach of childrens.

4.7 Lifting and handling

When unloading the unit, it is strongly recommended that sudden movements are avoided in order to protect internal components; unit can be lifted by using a forklift (1) or, in alternative using belts (2). Take care that the method of lifting does not damage the side panels or the cover; It is important to keep the unit vertical in order to avoid any risk of damage.



The fins of the coil are sharp; is suggested to use protective gloves.



The weight of some models could be unbalanced, before to start the handling verify the unit stability in order to avoid problems during the operations.



IS forbidden to put one unit over other also if are packed. If the unit is stored after receipt, must be away from the elemets even if packed.



The handling devices, cables, belts has to be in compliance with laws and local norms.

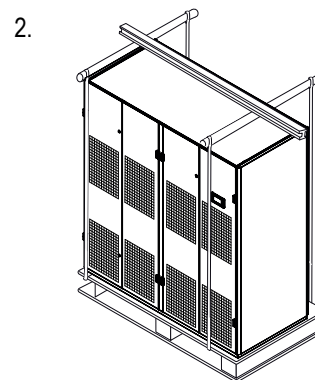
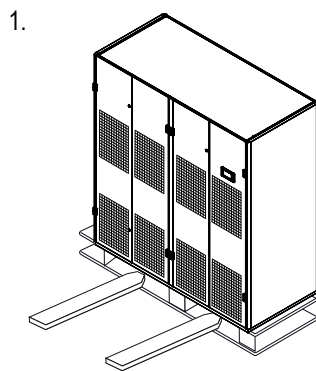

4.8 Location and minimum technical clearances

All models are designed for internal installation; Unit vibration level is very low. It is vital to avoid recirculation from discharge and suction in order to avoid poor performances or even the normal operation stops. For these reason it is necessary to observe the following clearance. The unit doesn't need a special fundations, as it can simply be placed on the installation site to work.



Pay attention to respect the clarences in order to allow ordinary and extraordinary maintenance. The guarantee does not costs related to platforms or handling equipment necessary for any repairs.



The installation site should be chosen in accordance with EN 378-1 and 378-3 standards; when choosing the installation site, all risks caused by accidental refrigerant leakage should be taken into consideration.

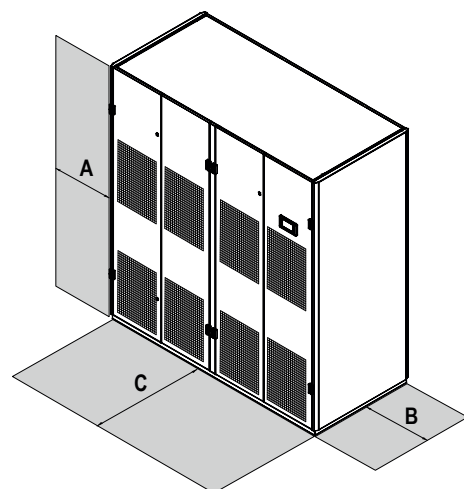

A	B	C
500 mm	500 mm	750 mm

4.9 Hydraulic connections

The units are provided dry-air charged (10bar on freon side); Pay attention during the discharge and make it just before connection of the cooling circuits. The units are designed to operate with air cooling, so the internal unit must be connected to the outside condenser unit through copper pipes.

The pipes installation has to be carried by an expert technician.



The fluid to be cooled has not to contain aggressive substances, or not compatibles with copper, carbon steel, aluminium and every material which unit is composed. For any doubt will be necessary send to Manufacturer a chemical analysis about the fluid in order to find the necessary solutions.

The cooling circuit has to be made by an expert designer and realized by a qualified technicians on behalf of the unit owner following the norms and regulations in force.

Hereafter are mentioned some indications for the cooling circuit realization:

- The pipes path has to be as short as possible in order to prevent the pressure drop on the circuit;
- The gas line must have an inclination of 1% ÷ 3% in the direction of remote condenser
- The pipelines has to be adequately bracketed and posed in order to allow the inspection and maintenance;
- The nominal pressure of the material used for the system has to be at least 45 bar;
- During the circuit realization be careful in order to avoid the dirty and dust entrance in the pipes;
- Along the circuit has to be positioned syphons for the oil entrainment must be installed and must have at least two diameters as radius of curvature..
- Once the connection is made is necessary to wash the circuit using a suitable substances in order to avoid that dirty and dust remain inside which can cause malfunctions, anomalies and damages during operation.
- The minimum distance between gas and liquid line must be 20 mm. Pipes must be also insulated as well indicated in the following table.
- For height difference great than 10 MT, a double pipe ascent is mandatory.

4.9.1 Thermal insulation of pipes

Pipeline type	Pipeline position	Thermal insulation
Gas	Inner	Mandatory
	Outer	For aesthetic or safety reasons only
Liquid	Inner	Not required
	Outer	Mandatory



Although the refrigerant is not classified as toxic, during the charging operation it is necessary to pay attention and operate safely in compliance with Legislative Decree 81/08; for this reason is mandatory to wear individual protective devices necessary to avoid contact, inhalation and ingestion of the fluid.

If one of the aforementioned cases occurs it is advisable to consult the gas safety data sheet for first AID and the emergency management operations; it is also advisable to bring them with the injured if a doctor intervention is needed.

4.9.1 Hydraulic connection areas



The connections are planned on the bottom for all the DXi.A and DX.A series unit; The option **BAS** can be requested in order to raise the unit (lateral connections base frame).

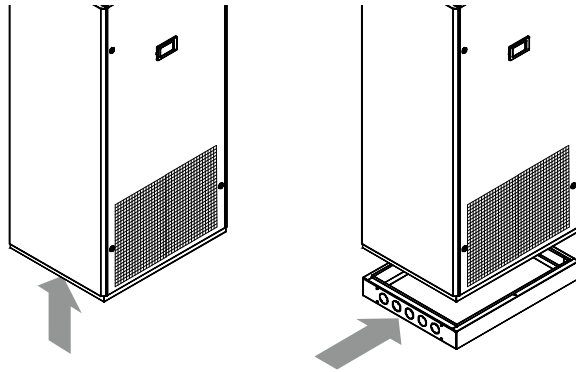

4.9.2 Indoor unit and remote condenser layout

Indoor unit at a higher level than the remote condenser

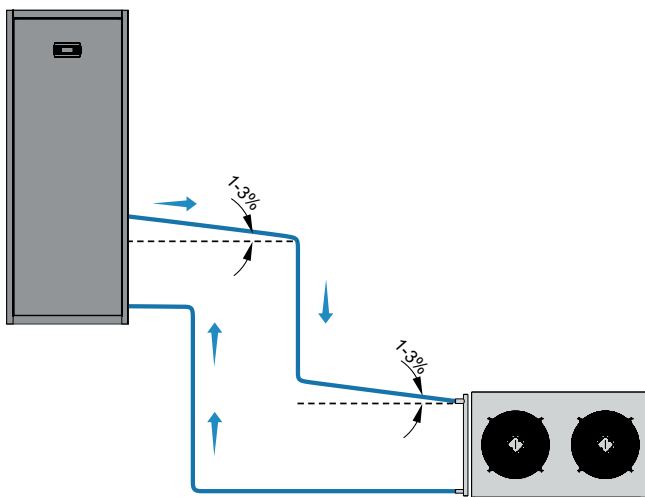

Indoor unit at a lower level than the remote condenser

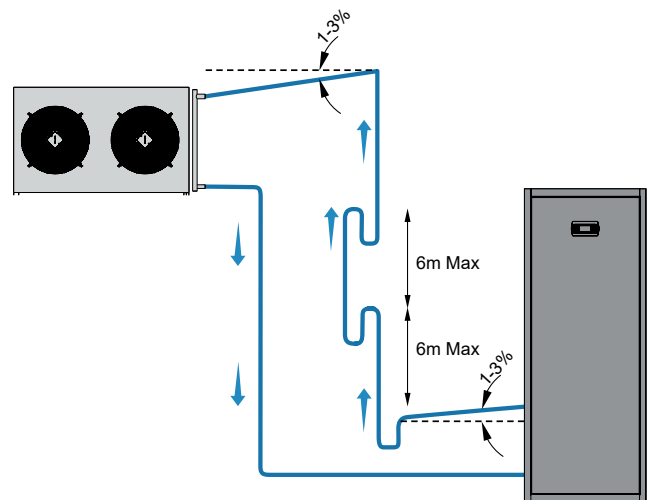

Indoor unit and remote condenser at the same height

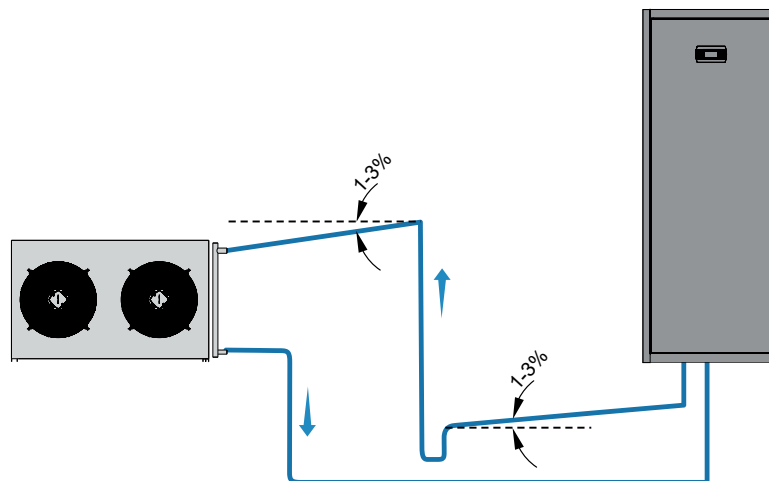

- A check valve must be installed at the condenser outlet. Follow the valve manufacturer's instructions for orientation and position.
- On vertical ascent sections, there must be syphons, at least every 6 metres, to allow the oil to return to the compressor.
- On horizontal sections of the discharge line provide for a 1÷3% gradient to facilitate the return of the oil to the compressor.

4.9.2 Relative position between indoor unit and remote condenser

Maximum distance between indoor unit and remote condenser	Up to 40 equivalent meters			From 40 to 100 equivalent meters
	from 20m to -3m	from -8m to -15m	from 30m to -8m	from 30m to -8m
Max. geodetic height difference between indoor unit and remote condenser ⁽¹⁾	from 20m to -3m	from -8m to -15m	from 30m to -8m	from 30m to -8m
Syphons for oil on the vertical ascent sections of the line	Every 6 m	Every 6 m	Every 6 m	Every 6 m
Remote condenser fan speed control installation	Mandatory	Mandatory	Mandatory	Mandatory
Remote condenser	Standard	Improved by 20% and with built-in liquid receiver	Improved by 20% and with built-in liquid receiver	Improved by 20% and with built-in liquid receiver
Hot gas coil	Allowed	Not Allowed	Not Allowed	Not Allowed
Solenoid valve on the liquid line	Not mandatory up to 20 equivalent meters. Mandatory over 20 metres equivalent.	Mandatory	Mandatory	Mandatory
Pipes *	Double ascent obligatory for height differences > 10 meters	Double ascent obligatory for height differences > 10 meters	Double ascent obligatory for height differences > 10 meters	Double ascent obligatory for height differences > 10 meters
External liquid pipe insulation	Allowed	Mandatory	Mandatory	Mandatory
Horizontal section gas line	Inclination 1÷3% to the remote condenser	Inclination 1÷3% to the remote condenser	Inclination 1÷3% to the remote condenser	Inclination 1÷3% to the remote condenser

(1) Positive values indicate that the remote condenser is higher than the indoor unit; negative levels indicate that the remote condenser is lower than the indoor unit.

(*) Only for DX.A 761-841-772-862-982-1002-1102-1252 e DXi.A 631-691-761-861-931-1021-1142

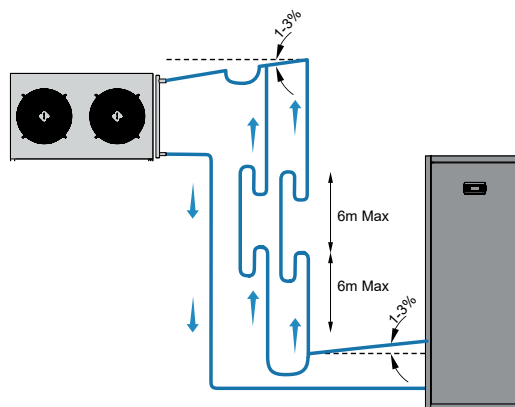

(*) Example of double gas pipe ascent.

4.9.3 Equivalent length of curves, shut-off valves and non-return valve

Nominal diameter (mm)					
12	0,50	0,25	0,75	2,10	1,90
14	0,53	0,26	0,80	2,20	2,00
16	0,55	0,27	0,85	2,40	2,10
18	0,60	0,30	0,95	2,70	2,40
22	0,70	0,35	1,10	3,20	2,80
28	0,80	0,45	1,30	4,00	3,30

4.10 Pipeline diameters

4.10.1 Hydraulic connections diameters

DXi.A	Hot water coil		Humidifier		Drain water outlet		
	IN (inch GAS)	OUT (inch GAS)	IN (inch GAS F)	mm	mm	(*) mm	(**) mm
61	1/2" M	1/2" M	3/4"	22	22	12	-
111	1/2" M	1/2" M	3/4"	22	22	12	-
121	3/4" M	3/4" M	3/4"	22	22	12	-
151	3/4" M	3/4" M	3/4"	22	22	12	-
181	3/4" M	3/4" M	3/4"	22	22	12	-
201	3/4" M	3/4" M	3/4"	22	22	12	-
251	3/4" M	3/4" M	3/4"	22	22	12	10
321	3/4" M	3/4" M	3/4"	22	22	12	10
381	3/4" M	3/4" M	3/4"	22	22	12	10
392	3/4" M	3/4" M	3/4"	22	22	12	10
472	3/4" M	3/4" M	3/4"	22	22	12	10
491	3/4" M	3/4" M	3/4"	22	22	12	10
531	1" GAS F	1" GAS F	3/4"	22	22	12	10
532	1" GAS F	1" GAS F	3/4"	22	22	12	10
631	1" 1/4 GAS F	1" 1/4 GAS F	3/4"	22	22	12	10
652	1" 1/4 GAS F	1" 1/4 GAS F	3/4"	22	22	12	10
691	1" 1/4 GAS F	1" 1/4 GAS F	3/4"	22	22	12	10
742	1" 1/4 GAS F	1" 1/4 GAS F	3/4"	22	22	12	10
761	1" 1/4 GAS F	1" 1/4 GAS F	3/4"	22	22	12	10
861	1" 1/4 GAS F	1" 1/4 GAS F	3/4"	22	22	12	10
931	1" 1/2 GAS F	1" 1/2 GAS F	3/4"	22	22	12	10
952	1" 1/2 GAS F	1" 1/2 GAS F	3/4"	22	22	12	10
1021	1" 1/2 GAS F	1" 1/2 GAS F	3/4"	22	22	12	10
1142	1" 1/2 GAS F	1" 1/2 GAS F	3/4"	22	22	12	10

(*) Option PB

(**) Option PBH

DX.A	Hot water coil		Humidifier		Drain water outlet		
	IN (inch GAS)	OUT (inch GAS)	IN (inch GAS F)	mm	mm	(*) mm	(**) mm
61	1/2" M	1/2" M	3/4"	22	22	12	-
71	1/2" M	1/2" M	3/4"	22	22	12	-
91	1/2" M	1/2" M	3/4"	22	22	12	-
111	3/4" M	3/4" M	3/4"	22	22	12	-
151	3/4" M	3/4" M	3/4"	22	22	12	-
181	3/4" M	3/4" M	3/4"	22	22	12	-
201	3/4" M	3/4" M	3/4"	22	22	12	-
221	3/4" M	3/4" M	3/4"	22	22	12	-
251	3/4" M	3/4" M	3/4"	22	22	12	-
232	3/4" M	3/4" M	3/4"	22	22	12	-
301	3/4" M	3/4" M	3/4"	22	22	12	-
321	3/4" M	3/4" M	3/4"	22	22	12	-
322	3/4" M	3/4" M	3/4"	22	22	12	-
391	3/4" M	3/4" M	3/4"	22	22	12	10
392	3/4" M	3/4" M	3/4"	22	22	12	10
431	3/4" M	3/4" M	3/4"	22	22	12	10
442	3/4" M	3/4" M	3/4"	22	22	12	10
451	1" GAS F	1" GAS F	3/4"	22	22	12	10
472	1" GAS F	1" GAS F	3/4"	22	22	12	10
511	1" GAS F	1" GAS F	3/4"	22	22	12	10
512	1" GAS F	1" GAS F	3/4"	22	22	12	10
531	1" 1/4 GAS F	1" 1/4 GAS F	3/4"	22	22	12	10
602	1" 1/4 GAS F	1" 1/4 GAS F	3/4"	22	22	12	10
672	1" 1/4 GAS F	1" 1/4 GAS F	3/4"	22	22	12	10
742	1" 1/4 GAS F	1" 1/4 GAS F	3/4"	22	22	12	10
761	1" 1/4 GAS F	1" 1/4 GAS F	3/4"	22	22	12	10
762	1" 1/4 GAS F	1" 1/4 GAS F	3/4"	22	22	12	10
772	1" 1/4 GAS F	1" 1/4 GAS F	3/4"	22	22	12	10
841	1" 1/4 GAS F	1" 1/4 GAS F	3/4"	22	22	12	10
862	1" 1/4 GAS F	1" 1/4 GAS F	3/4"	22	22	12	10
982	1" 1/2 GAS F	1" 1/2 GAS F	3/4"	22	22	12	10
1002	1" 1/2 GAS F	1" 1/2 GAS F	3/4"	22	22	12	10
1102	1" 1/2 GAS F	1" 1/2 GAS F	3/4"	22	22	12	10
1252	1" 1/2 GAS F	1" 1/2 GAS F	3/4"	22	22	12	10

(*) Option PB

(**) Option PBH

4.9.4 Refrigerant connections diameters - DX.A single circuit

DX.A	DX.A single circuit	Frame	Circuits / Compressors	Ø Supply connection (mm)	Ø Liquid connection (mm)	Equivalent length in meters							
						≤ 10 m		> 10 ≤ 20 m		> 20 ≤ 40 m		> 40 ≤ 100 m	
						Ø Supply pipe (mm)	Ø Liquid pipe (mm)	Ø Supply pipe (mm)	Ø Liquid pipe (mm)	Ø Supply pipe (mm)	Ø Liquid pipe (mm)	Ø Supply pipe (mm)	Ø Liquid pipe (mm)
61	X	1	1/1	10	10	12	10	12	10	12	10	12	10
71	X	1	1/1	12	10	12	10	12	10	12	10	12	10
91	X	1	1/1	12	10	12	10	12	10	16	10	16	12
111	X	2	1/1	12	12	12	12	16	12	16	12	16	12
151	X	2	1/1	12	12	12	12	16	12	16	12	16	12
181	X	3	1/1	16	12	16	12	18	12	18	16	18	16
201	X	3	1/1	16	12	16	12	18	12	18	16	18	16
221	X	3	1/1	16	16	16	16	18	16	18	16	22	16
251	X	4	1/1	16	16	18	16	18	16	22	16	22	16
301	X	4	1/1	18	16	22	16	22	16	22	16	22	16
321	X	4	1/1	18	16	22	16	22	16	22	16	22	16
391	X	4,5	1/1	22	16	22	16	22	16	22	16	28	18
431	X	4,5	1/1	22	16	22	16	22	16	22	16	28	18
451	X	5	1/1	22	16	22	16	22	16	28	18	28	18
511	X	5	1/1	22	16	22	16	22	16	28	18	28	18
531	X	6	1/1	22	16	22	16	28	18	28	18	28	18
761	X	7	1/2	28	22	28	22	28	22	28	22	35	22
841	X	7	1/2	28	22	28	22	28	22	35	22	35	22

4.9.4.1 Refrigerant connections diameters - DX.A double circuit

DX.A	DX.A single circuit	Frame	Circuits / Compressors	Ø Supply connection (mm)	Ø Liquid connection (mm)	Equivalent length in meters							
						≤ 10 m		> 10 ≤ 20 m		> 20 ≤ 40 m		> 40 ≤ 100 m	
						Ø Supply pipe (mm)	Ø Liquid pipe (mm)	Ø Supply pipe (mm)	Ø Liquid pipe (mm)	Ø Supply pipe (mm)	Ø Liquid pipe (mm)	Ø Supply pipe (mm)	Ø Liquid pipe (mm)
232	X	4	2/2	2x16	2x12	2x16	2x12	2x16	2x12	2x18	2x12	2x18	2x12
322	X	4	2/2	2x16	2x12	2x16	2x12	2x16	2x12	2x18	2x12	2x18	2x12
392	X	4,5	2/2	2x16	2x12	2x16	2x12	2x16	2x12	2x18	2x16	2x18	2x16
442	X	4,5	2/2	2x16	2x16	2x16	2x16	2x22	2x16	2x22	2x16	2x22	2x16
472	X	5	2/2	2x22	2x16	2x22	2x16	2x22	2x16	2x22	2x16	2x22	2x16
512	X	5	2/2	2x22	2x16	2x22	2x16	2x22	2x16	2x22	2x16	2x22	2x16
602	X	6	2/2	2x22	2x16	2x22	2x16	2x22	2x16	2x22	2x16	2x22	2x18
672	X	6	2/2	2x22	2x16	2x22	2x16	2x22	2x16	2x22	2x16	2x22	2x18
742	X	6	2/2	2x22	2x16	2x22	2x16	2x22	2x16	2x22	2x16	2x22	2x18
762	X	7	2/2	2x22	2x16	2x22	2x16	2x22	2x16	2x28	2x18	2x28	2x18
772	X	7	2/4	2x22	2x16	2x22	2x16	2x22	2x16	2x28	2x18	2x28	2x18
862	X	7	2/4	2x22	2x16	2x22	2x16	2x22	2x16	2x28	2x18	2x28	2x12
982	X	8	2/4	2x22	2x16	2x22	2x16	2x22	2x18	2x28	2x18	2x28	2x18
1002	X	8	2/2	2x22	2x16	2x22	2x16	2x28	2x18	2x28	2x18	2x28	2x18
1102	X	8	2/4	2x28	2x22	2x28	2x22	2x28	2x22	2x28	2x22	2x35	2x22
1252	X	8	2/4	2x28	2x22	2x28	2x22	2x28	2x22	2x28	2x22	2x35	2x22

4.10.4 Refrigerant connections diameters - DXi.A single circuit

DXi.A	DXi.A single circuit	DXi.AF single circuit	Frame	Circuits / Compressors	Ø Supply connection (mm)	Ø Liquid connection (mm)	Equivalent length in meters							
							≤ 10 m		> 10 ≤ 20 m		> 20 ≤ 40 m		> 40 ≤ 100 m	
							Ø Supply pipe (mm)	Ø Liquid pipe (mm)	Ø Supply pipe (mm)	Ø Liquid pipe (mm)	Ø Supply pipe (mm)	Ø Liquid pipe (mm)	Ø Supply pipe (mm)	Ø Liquid pipe (mm)
61	X		2	1/1	10	10	12	10	12	10	12	10	12	10
111	X		2	1/1	12	10	12	10	12	10	12	10	16	12
121	X		2	1/1	12	10	12	10	12	10	16	10	16	12
151	X		2	1/1	12	12	12	12	16	12	16	12	16	12
181	X	X	3	1/1	12	12	12	12	16	12	16	12	18	16
201	X		3	1/1	16	16	16	16	18	16	18	16	18	16
251	X	X	4	1/1	16	16	18	16	18	16	22	16	22	16
321	X		4	1/1	16	16	22	16	22	16	22	16	22	16
381	X	X	4,5	1/1	16	16	22	16	22	16	22	16	22	16
491	X		4,5	1/1	22	16	22	16	22	16	28	18	28	18
531	X	X	5	1/1	22	16	22	16	22	16	28	18	28	18
631	X	X	6	1/2	28	22	28	22	28	22	28	22	28	22
691	X		6	1/2	28	22	28	22	28	22	28	22	28	22
761	X	X	7	1/2	28	22	28	22	28	22	28	22	35	22
861	X		7	1/2	35	22	35	22	35	22	35	22	35	22
931	X	X	8	1/2	35	22	35	22	35	22	35	22	35	28
1021	X		8	1/2	35	28	35	28	35	28	35	28	35	28

4.10.5 Refrigerant connections diameters - DXi.A double circuit

DXi.A	DXi.A double circuit	DXi.AF double circuit	Frame	Circuits / Compressors	Ø Supply connection (mm)	Ø Liquid connection (mm)	Equivalent length in meters							
							≤ 10 m		> 10 ≤ 20 m		> 20 ≤ 40 m		> 40 ≤ 100 m	
							Ø Supply pipe (mm)	Ø Liquid pipe (mm)	Ø Supply pipe (mm)	Ø Liquid pipe (mm)	Ø Supply pipe (mm)	Ø Liquid pipe (mm)	Ø Supply pipe (mm)	Ø Liquid pipe (mm)
392	X	X	4,5	2/2	2x16	2x16	2x16	2x16	2x16	2x16	2x18	2x16	2x18	2x16
472	X		4,5	2/2	2x16	2x16	2x16	2x16	2x18	2x16	2x22	2x16	2x22	2x16
532	X	X	5	2/2	2x16	2x16	2x22	2x16	2x22	2x16	2x22	2x16	2x22	2x16
652	X	X	6	2/2	2x16	2x16	2x22	2x16	2x22	2x16	2x22	2x18	2x22	2x18
742	X	X	7	2/2	2x16	2x16	2x22	2x16	2x22	2x16	2x22	2x18	2x22	2x18
952	X	X	8	2/2	2x22	2x16	2x22	2x16	2x22	2x16	2x22	2x18	2x28	2x18
1142	X		8	2/4	2x22	2x16	2x22	2x16	2x22	2x16	2x28	2x18	2x28	2x22

4.13.6 Additional oil charge

The quantity of oil here mentioned in the table, should be added for any syphon and meter of liquid line.

Liquid line diameter [mm]	Additional charge per line meter (g/m)	Additional charge per syphon (g)
35	45	160
28	27	100
22	16	60
18	11	40
16	9	30
12	5	15
10	3	10

The syphon must respect the following dimensions

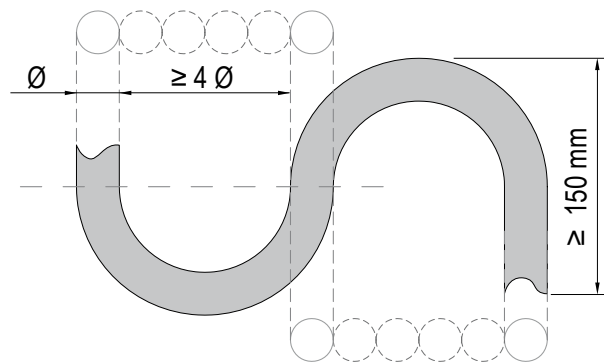

4.11 Tightness test, vacuum and charge



The units are supplied without refrigerant charge and must be subjected to the operations described below.

For a right and reliable operation of the system, once the connection lines between the indoor and the outdoor units are carried out, it is extremely important to clear the circuit of any air, humidity, non-condensable gas and, in general, of any polluting substance before carrying on the refrigerant charge.

The presence of solid particles, such as metal dust, welding debris and very small dirty (hardly to be detected by the mechanical filters), can cause serious damages to the surfaces in motion also involving a reduction of the compressor efficiency and lifetime.



Do not drill the cooling circuit, if the total removal of metal particles produced cannot be granted

The presence of too much humidity inside the cooling circuit can lead to negative consequences. Humidity can freeze inside the thermostatic valve and can even clog it up, stopping the unit for low pressure alarm. A significant amount of humidity can very quickly saturate the drier filters which should be replaced (with consequent system stop).

Humidity chemically interacts with refrigerants and polyester lubricant oils (normally used with refrigerant type R407C, R134a, R404A, R410A, etc.). This interaction creates acid substances that, if present in remarkable amount, can damage the compressor electric motor insulation causing motor burns and oxidizing copper pipes, so generating solid impurities.



Reduce as far as possible the exposure of the circuit and its parts to the atmosphere, especially if used compressors are charged with polyester oil.

If non-condensable gases are not accurately eliminated from the circuit, they can be collected inside the condenser and the liquid receiver. In the first case, they can cause a reduction of the useful thermal exchange surface, therefore a condensing temperature increase with a resulting reduction of the system energy efficiency and reliability. In the worst cases, the unit can be stopped by the high pressure switch activation.

The thermostatic valve, for the presence of high concentration of non-condensable gases in the liquid receiver, could not be suitably fed by just liquid refrigerant, as required, but also by a mixture of refrigerant and non-condensable vapours. This causes a remarkable reduction of the evaporating temperature (up to the activation of the low pressure switch, in worst cases) , that means a reduction of the unit cooling capacity and of the system efficiency and lifetime.

The operations to be carried out are:

- a. Tightness test
- b. Vacuum and dehydration
- c. Refrigerant charge

4.10.1. Leak test

In order to detect any possible leak in the cooling circuit, follow the here below steps:

- a. Charge the cooling circuit with refrigerant gas up to a pressure of 1 bar.
- b. Add dry nitrogen by means of bottles with reducer up to a pressure of 15 bar.
- c. Locate the eventual leaks by means of a leak detector having a calibration (5 gr/year or better) suitable for the employed refrigerant. In particular, check the joints involved in the repairs.
- d. In case a leak is detected, discharge the cooling circuit, repair it and repeat again the leak test.



Do not use oxygen, hydrogen or any other reactive and inflammable gases to pressurise the cooling circuit: use dry nitrogen only.



It is forbidden to charge the circuit and, in particular, the low pressure side, at a pressure higher than 16 bar.

4.10.2 Vacuum execution

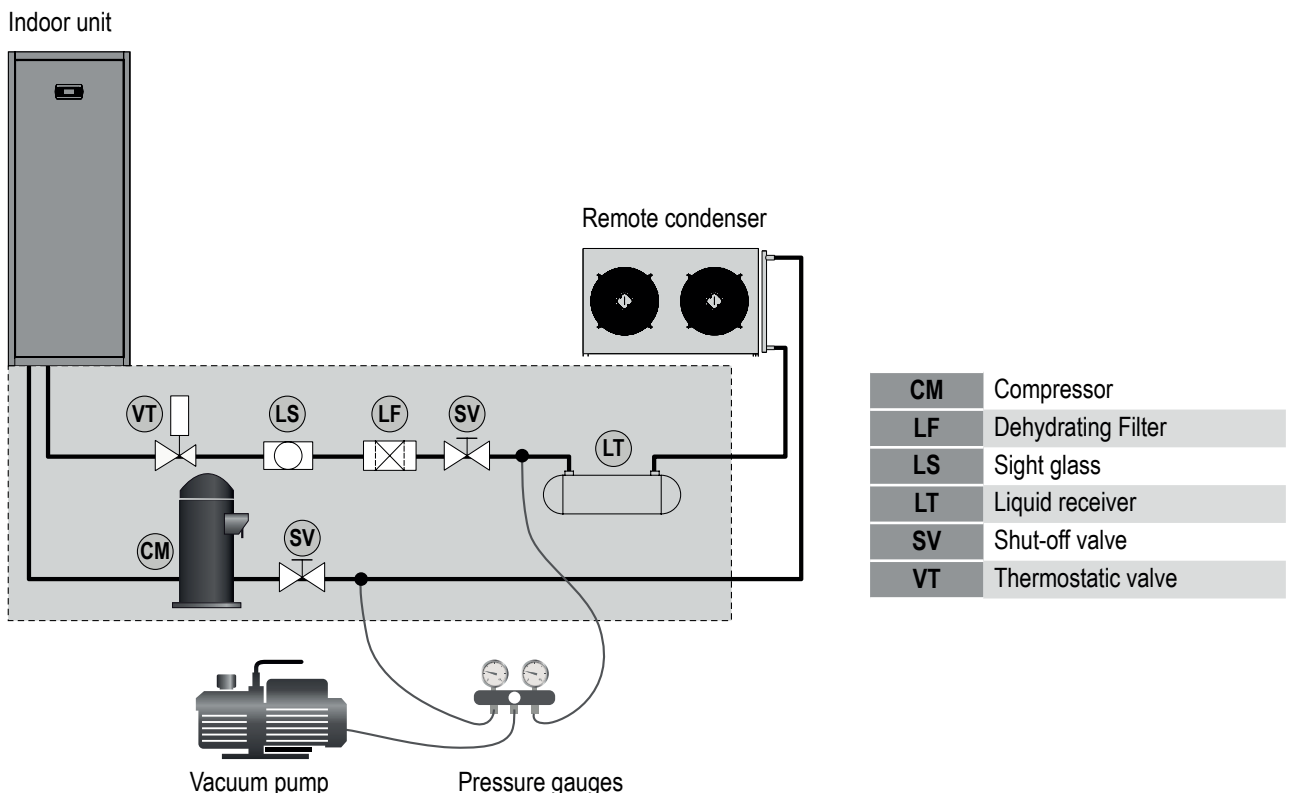



Do not use compressor for cooling circuit vacuum execution.



Check that all the valves are open in order to do not have insulated circuit sections.

To obtain a suitable vacuum, use a two-stage pump with suitable features.

It is normally considered suitable, a vacuum degree able to grant a humidity content in the refrigerant lower than 100 ppm, at unit start; in this way, during the operation, the drier filter can keep this value below 20 ppm.

Once the cooling lines are completed and no leaks detected, realize the system vacuum as here below described:

a. Connect a vacuum pump with a suitable water flow capacity (a two-stage pump able to keep a pressure of 0,02 mbar) to the system, by using the charge connections on discharge side and liquid receiver (if the latter is not present, the charge connection is placed on the suction pipe). The charge/discharge positions are clearly marked by stickers, see figure.

b. Let the vacuum pump work until the pressure shown on the appropriate vacuum meter will be 0,04 mbar at least.



Vacuum degree must be always checked by vacuum manometers on the circuit and not by the instruments on the pump.

c. Isolate the pump from the circuit by means of the special cut-off valves and wait 30 min.

d. If pressure increases during all the pump stop period, or if it is impossible to reach the desired pressure value, it means that there is a leak in the circuit. Detect and repair the leak, then repeat the procedure starting from step b).

e. If pressure increases till a balance value, it means the circuit contains a big amount of humidity. In this case, introduce Anhydrous nitrogen in the circuit (up to about 2 bar) and repeat steps b), c) and e) for at least twice; then proceed with step f).

f. If pressure stabilises after a short increase, it means the circuit is leak proof and reasonably dried. Open the pump shut-off valves once more and, after pressure has returned lower than 10 mbar, let it operate for 2-4 hours according to the circuit size.



During the vacuum, do not let the compressor work and do not carry out any kind of test.



If the cooling circuit has been kept open only for a little while, operations described in steps a), b) and c) are usually enough to obtain a suitable vacuum.

If the suitable equipment is not available or if the circuit has been kept open for long, it could be required to repeat steps b) and c), using the refrigerant instead of the nitrogen to break the vacuum.

4.12 Refrigerant charge execution



Do not use a refrigerant different from the one indicated in the Identification Tag



Avoid any refrigerant gas release in the environment during the charge operations.



If the refrigerant is a mixture of several components, such as R410A, introduce it in the circuit in a liquid state to avoid the components separation. On this purpose, bottles are provided with two different valves: one for vapour and one for liquid.

Once vacuum is completed, the circuit must be charged with the right refrigerant and if required antifreeze oil quantity.

- a. Connect the refrigerant bottle to a 1/4" SAE male (7/16" – 20 UNF) charge connection placed on the liquid refrigerant line.
- b. Let a small quantity of liquid go out in order to remove any air from the connection pipe.
- c. Open the bottle valve and let the refrigerant flow in the cooling circuit for pressure difference; replace the refrigerant bottle once empty.
- d. If pressure inside the circuit reaches a balance value at room temperature, the refrigerant cannot spontaneously flow out from the cylinder any more. Therefore, it should be required to connect the bottle to a charge connection, placed on the suction line.
- e. Let the air vent from the connection pipe as indicated at step b).
- f. Start the compressor and once the max load is reached, open the bottle valve and complete the charge. Replace the bottle when necessary.
- g. Charge small quantities of refrigerant one after the other, checking each time operating pressure and temperatures to avoid a system overload.
- h. The charge must be completed by comparing the quantity of refrigerant introduced with the value indicated on the data sheet.
- i. Check that the charge introduced in the circuit is the right one, by checking the sight glass and measuring the liquid sub-cooling and the suction superheating.

The connection pipes must be as shortest as possible and must be provided with valves in order to reduce the possibility of refrigerant leaks. To make the charge operation easy, the following tables shows, just as an indication, the required refrigerant charges for the different types of indoor units and the corresponding connecting pipes. For a correct calculation of the refrigerant quantity, also consider the volume of the outdoor units cooling circuit and of any other installed component (such as additional liquid receivers, oil separators, etc.).

Use only new refrigerant or recycled one whose composition is known and suitable for use in cooling circuits.

The recovered refrigerant in liquid state can be re-used in the same unit, if in the circuit there is no inert gas or any other pollutants.

Before charging the refrigerant from a tank, check quality and quantity of contained fluid.

The amount of refrigerant charged in the cooling circuit must be measured (by weight or by volume). It is good rule charging the refrigerant in liquid state.

If the refrigeration lines are particularly long or if oil separators are installed on the compressors' discharge, it will be necessary to add an appropriate amount of incongelable oil.



Check the compatibility of the used oil with the oil loaded in the compressor (detectable on the compressor's nameplate).

If oil separators are used, add the amount of lubricant recommended by the Manufacturer.

For refrigerant lines longer than 30 m, charge approx. 0.2 kg of oil every 10 m of additional pipework.

In any case, check the correct oil charge by verifying the oil level in the sight glass of the compressor about 30 minutes after running at full capacity.

It is suggested to charge 1 kg of oil for every 10 kg of refrigerant supplied in the system.



An overload oil charge can cause loss of efficiency of the system and compressor failure.

4.12.1 Line refrigerant charge

External Ø	DISCHARGE Condensing temperature = 48°C Discharge temperature = 73°C	LIQUID Condensing temperature = 48°C SC = 5K
	R410A charge (kg/m)	R410A charge (kg/m)
6	0,0014	0,0133
10	0,0052	0,0508
12	0,0081	0,0786
16	0,0153	0,1481
18	0,0199	0,1935
22	0,0281	0,2729
28	0,0487	0,4724
35	0,0798	0,7740
42	0,1185	1,1496
54	0,1948	1,8896
64	0,2805	2,7211
76	0,4039	3,9183

4.13 DXi.A Refrigerant circuit layout

AC	Air heat exchanger	PRV	Safety valve
BC	Hot water coil	PSH	High pressure switch
BG	Hot gas coil	PSL	Low pressure switch
BW	Low temp. Operation up to -40°C	PT	Pressure transducer
CM	Compressor	RE	Electric heaters
DH	Dehumidifier	RV	Modulating valve
EF	Fan	REM	Oversized electric heaters
EHC	Crank-case heater	SV	Shut-off valve
EV	Solenoid valve on liquid line	TS	Safety thermostatic valve
FSR	Fan speed regulator	TT	Temperature probe
H	Humidifier	TWV	3-Way valve
HG	Hot gas	VP	Evaporator
HT	Humidity probe	VT	Thermostatic expansion valve
LF	Dehydrating filter	WC	Water coil
LS	Sight glass	YVCA	Humidifier fill valve
LT	Liquid receiver	YVSA	Humidifier drain valve
NR	Non-return valve	-----	Optional

4.13.1 DXi.A Refrigerant circuit layout - 1 Circuit / 1 Compressor

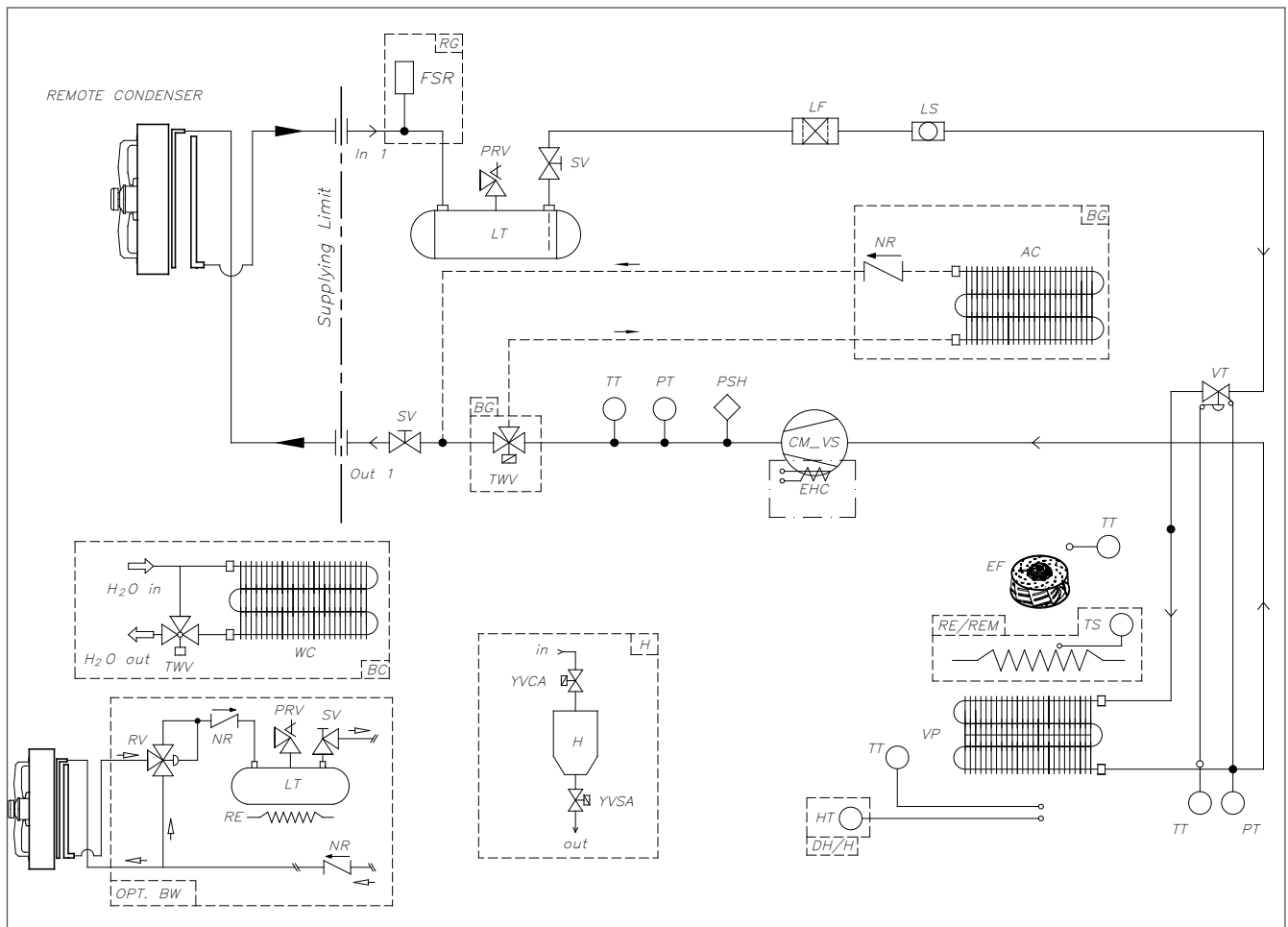

4.13.2 DXi.A Refrigerant circuit layout - 2 Circuits / 2 Compressors

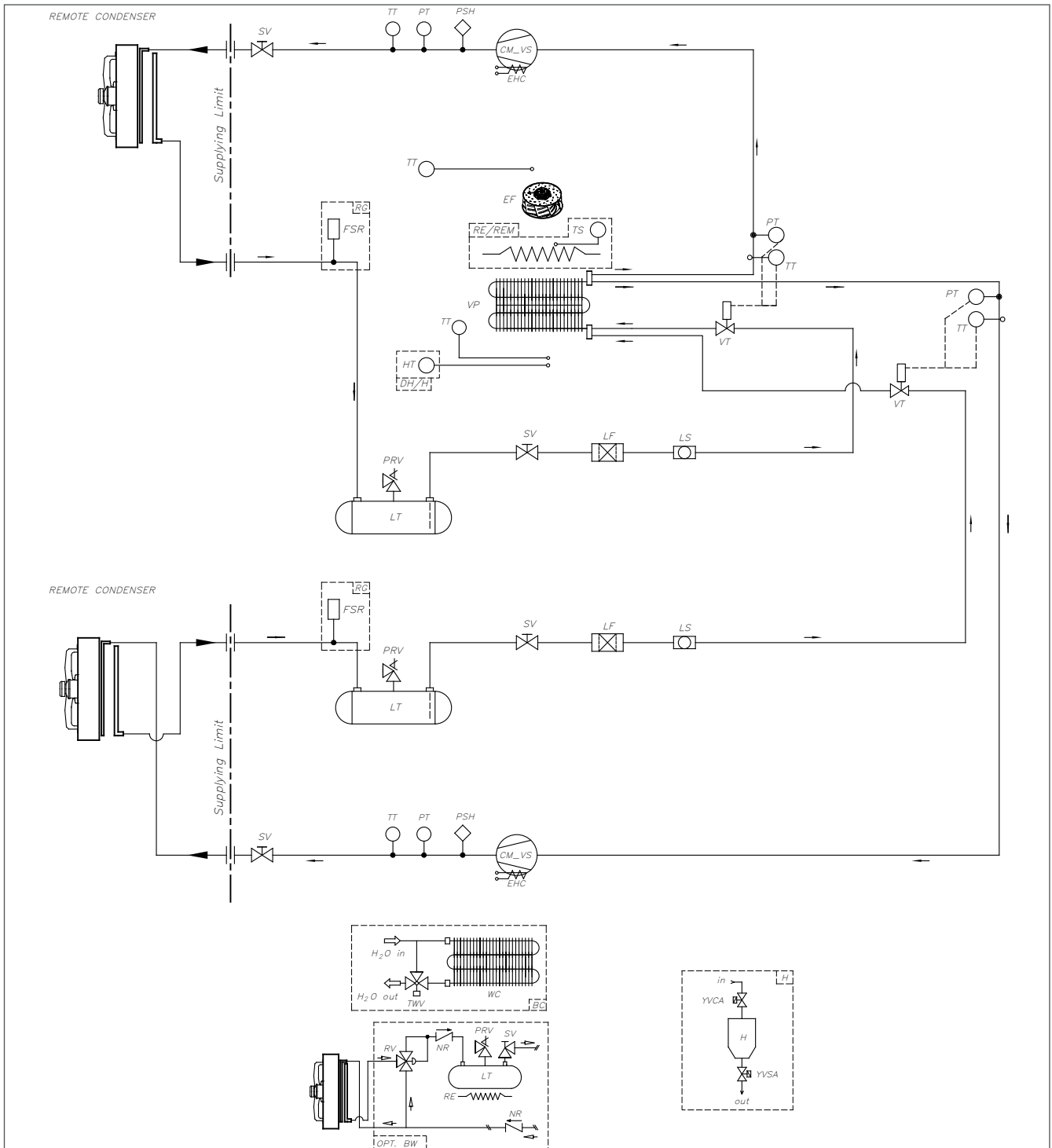

4.13.3 DXi.A Refrigerant circuit layout - 1 Circuit / 2 Compressors

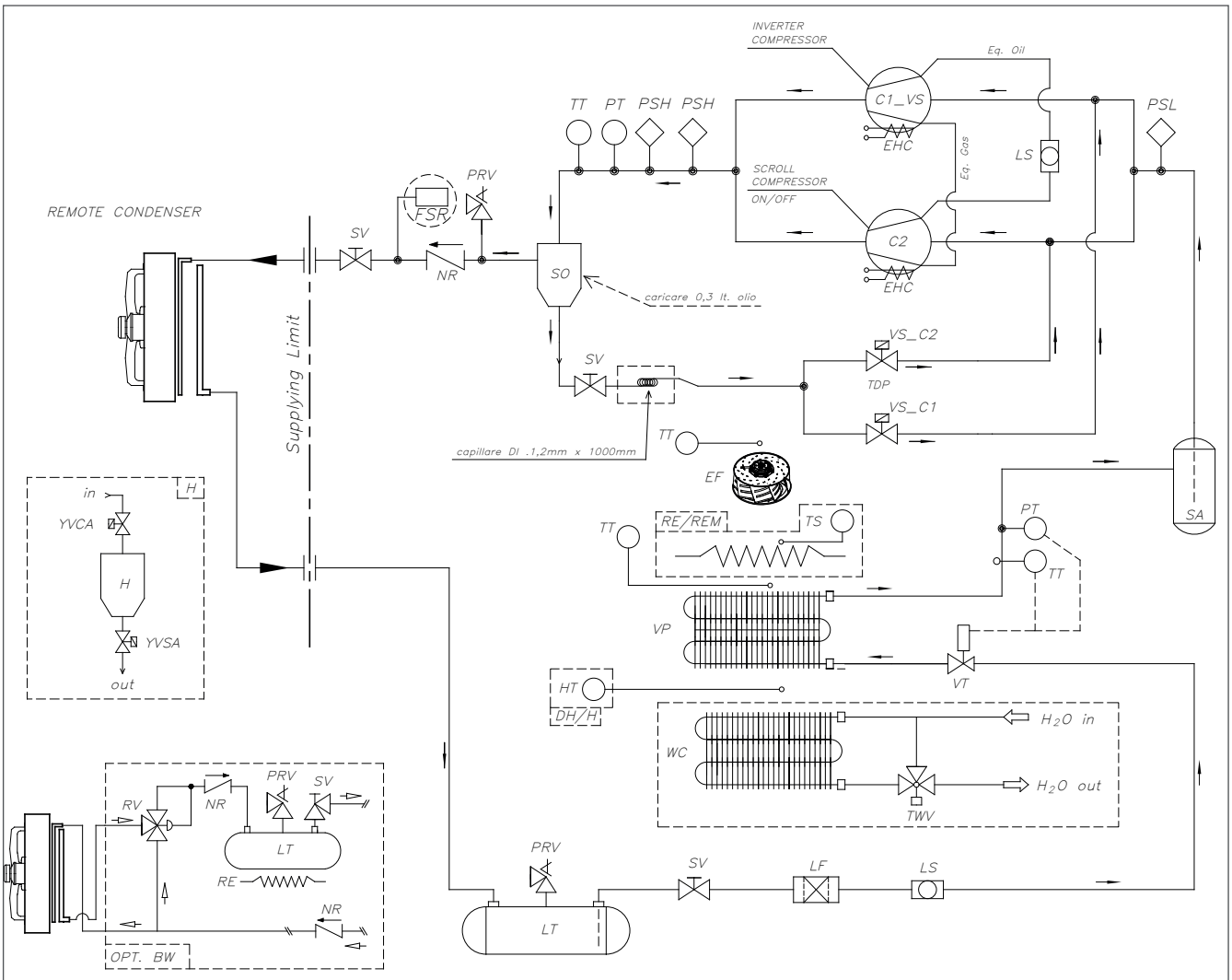

4.13.4 DXi.A Refrigerant circuit layout - 2 Circuits / 4 Compressors

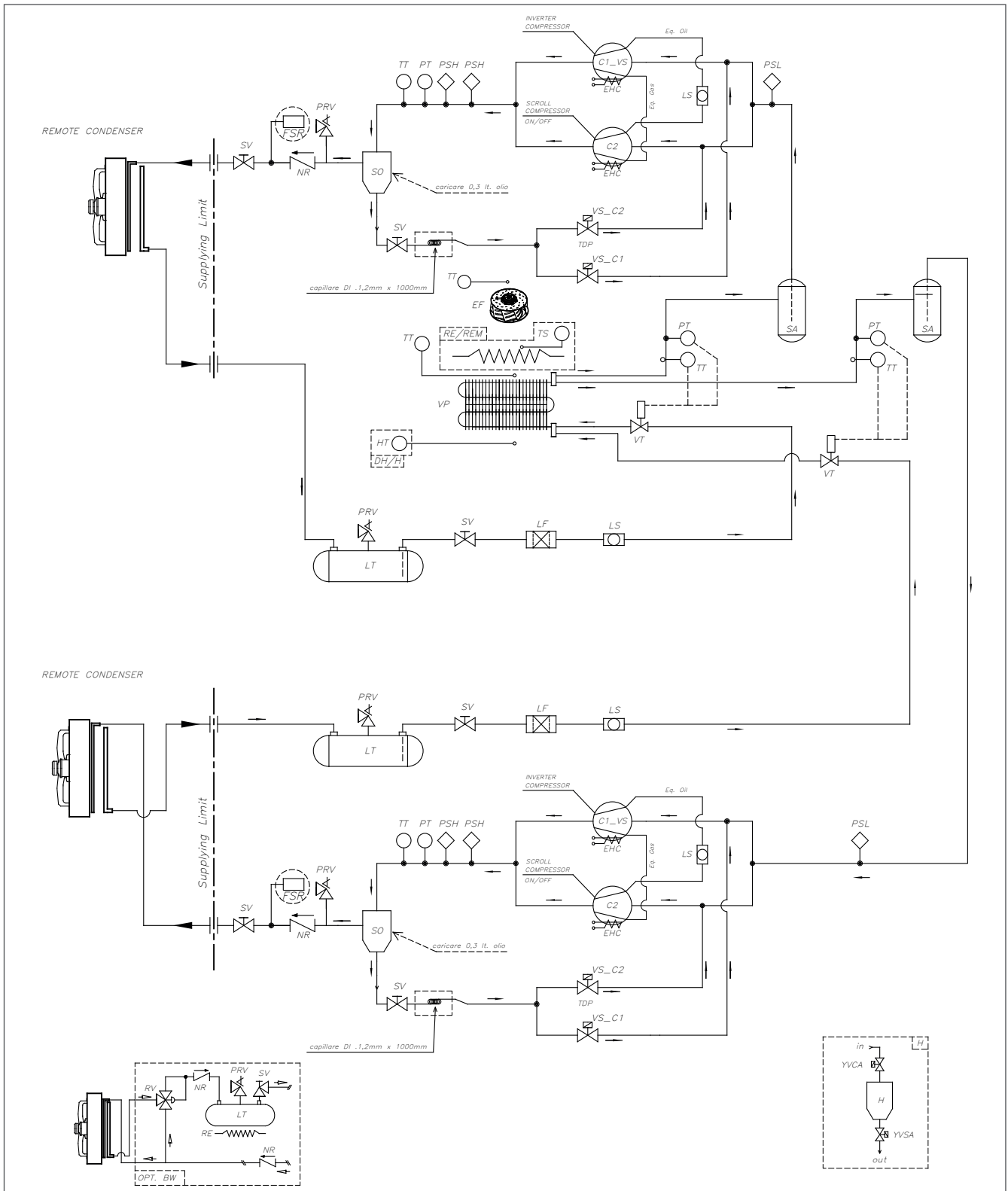

4.14 DX.A Refrigerant circuit layout

AC	Air heat exchanger	PRV	Safety valve
BC	Hot water coil	PSH	High pressure switch
BG	Hot gas coil	PSL	Low pressure switch
BW	Low temp. Operation up to -40°C	PT	Pressure transducer
CM	Compressor	RE	Electric heaters
DH	Dehumidifier	RV	Modulating valve
EF	Fan	REM	Oversized electric heaters
EHC	Crank-case heater	SV	Shut-off valve
EV	Solenoid valve on liquid line	TS	Safety thermostatic valve
FSR	Fan speed regulator	TT	Temperature probe
H	Humidifier	TWV	3-Way valve
HG	Hot gas	VP	Evaporator
HT	Humidity probe	VT	Thermostatic expansion valve
LF	Dehydrating filter	WC	Water coil
LS	Sight glass	YVCA	Humidifier fill valve
LT	Liquid receiver	YVSA	Humidifier drain valve
NR	Non-return valve	-----	Optional

4.14.1 DX.A Refrigerant circuit layout - 1 Circuit / 1 Compressor

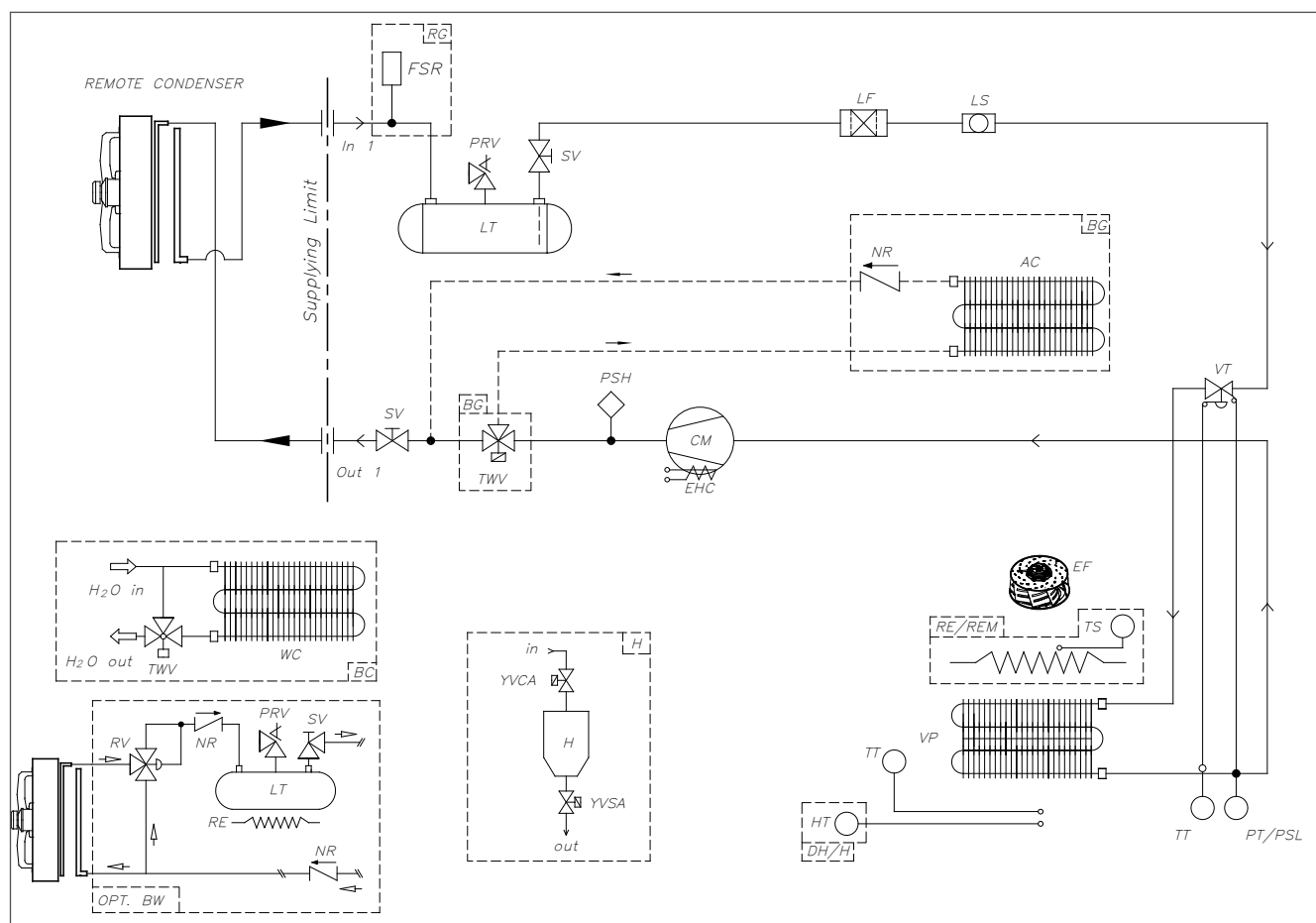

4.14.2 DX.A Refrigerant circuit layout - 2 Circuits / 2 Compressors

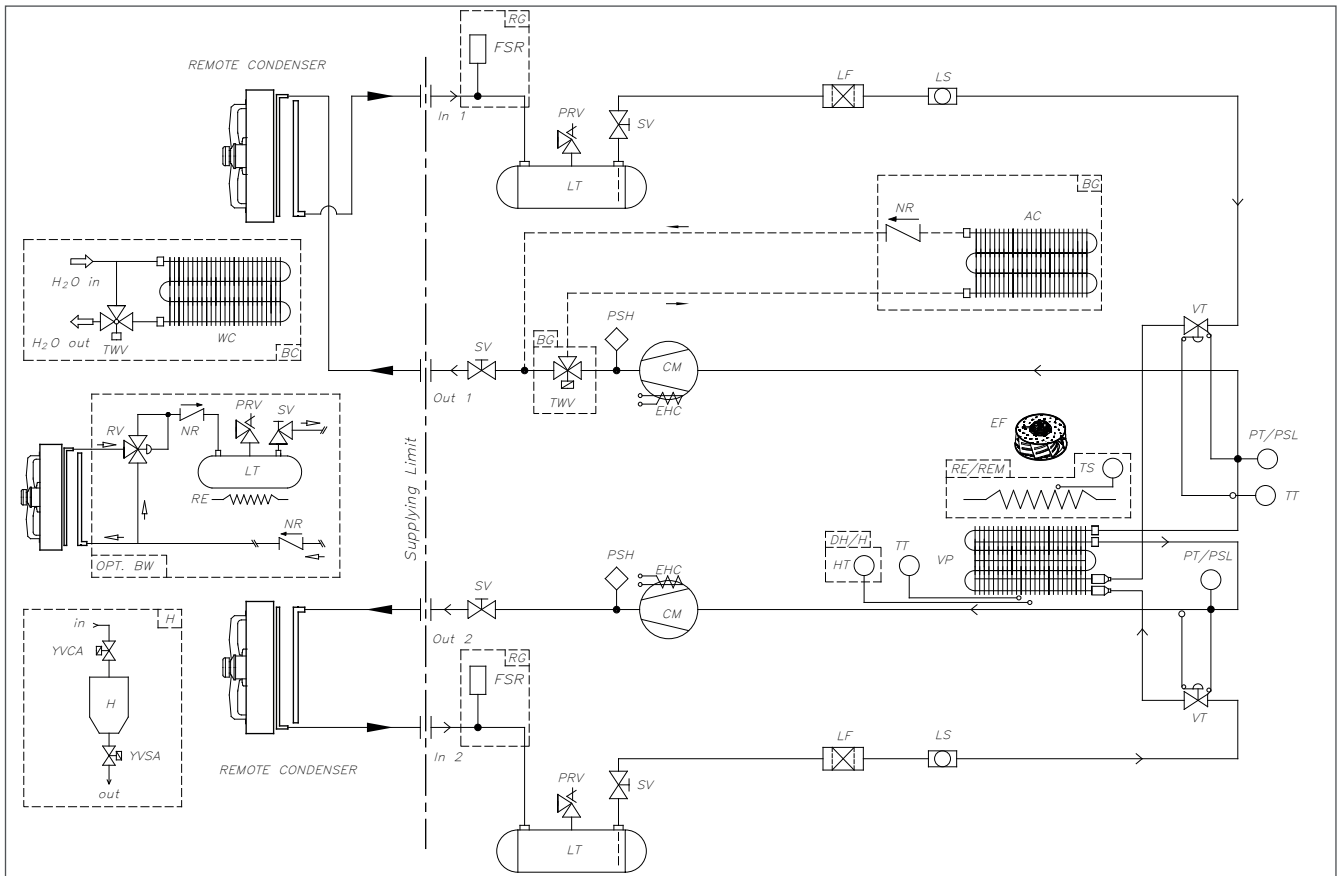

4.14.3 DX.A Refrigerant circuit layout - 1 Circuit / 2 Compressors

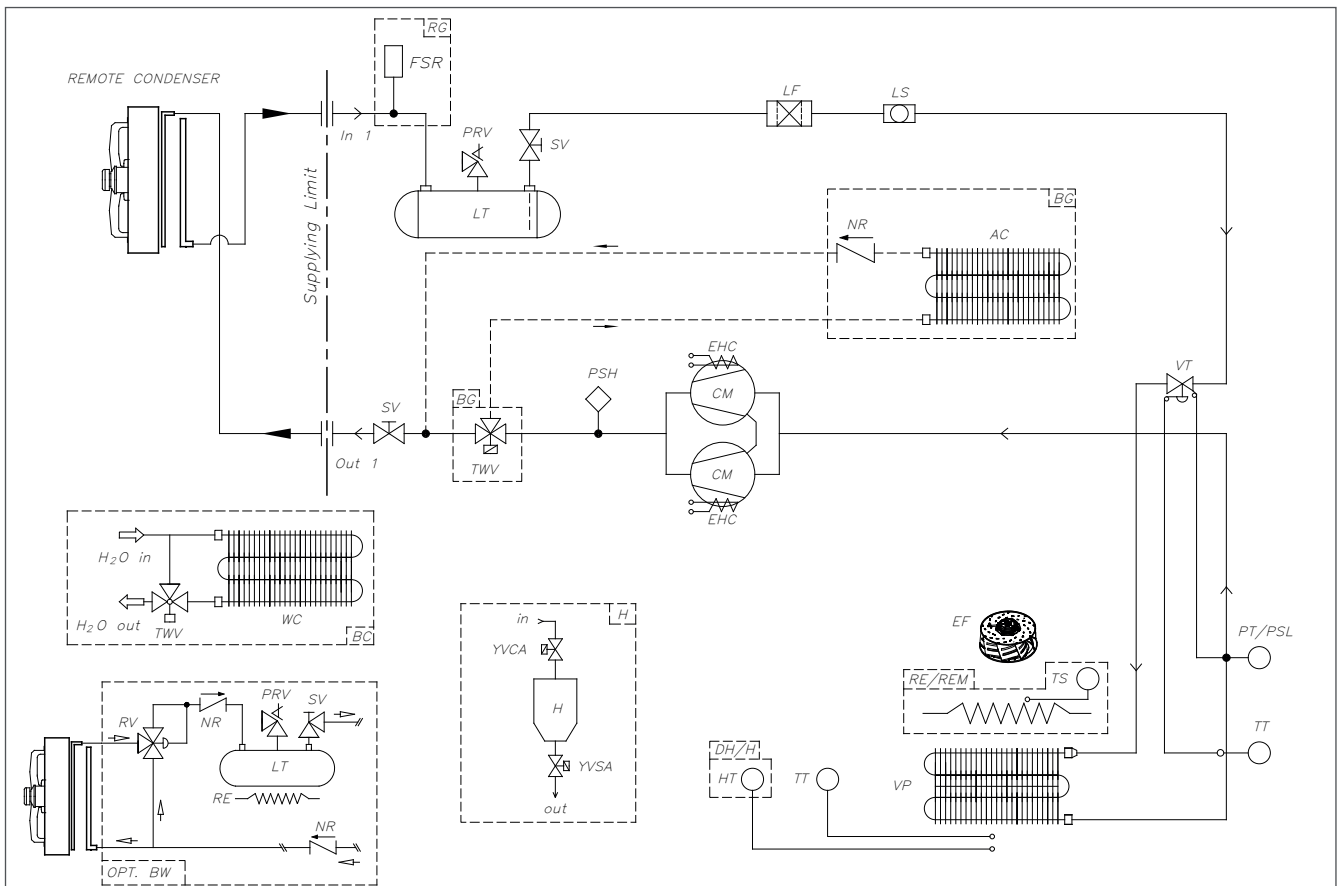

4.14.4 DX.A refrigerant circuit layout - 2 Circuits / 4 Compressors

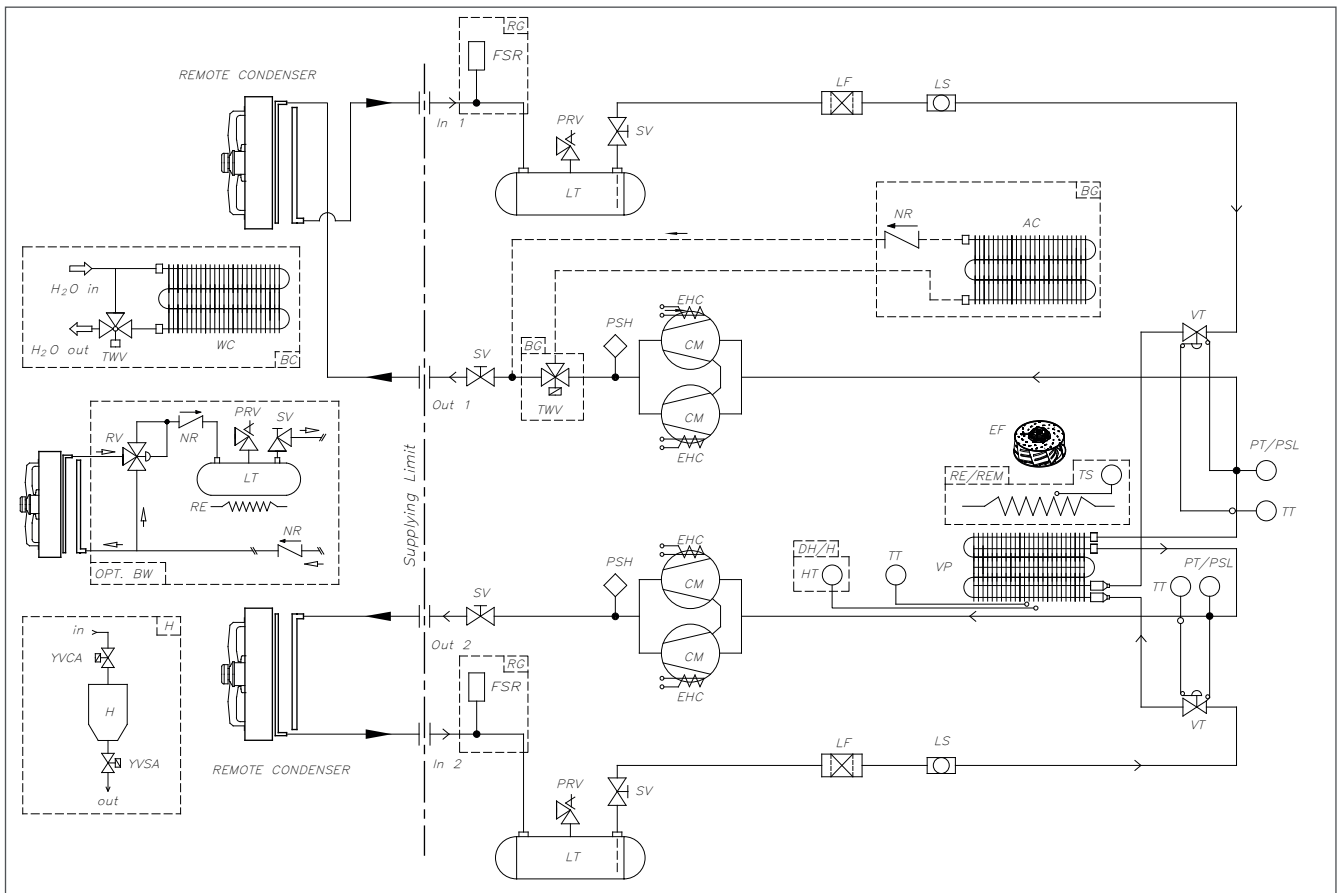

4.15 Condensing water connection

4.15.1 Condensing water connection

The unit is provided with a painted material basin for condensate collection situated under the coil, connected through a flexible plastic tube with syphon (with internal diameter of 19mm) to the drain collector which has to respect a small downward slope (around 1%) to exhaust direction



In the discharge line a siphon must be made with a minimum head equal to the prevalence in fan's suction, in any case never less than 35mm.

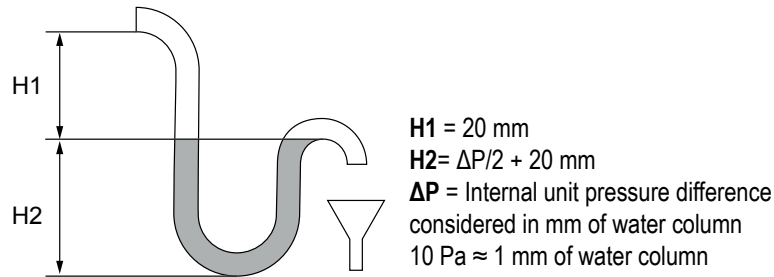

4.16 Renewal air intake connection (Optional) (PR)

This option is installed inside of the unit on the left side, on request on the right one.

The renewal air duct coming from the nearest outlet has to be fixed to the collar located on the unit lateral panel.

The module of this option is provided with a flat filter, easily removable for his cleaning or replacement (moving the special catch).

Vers. U/V/B

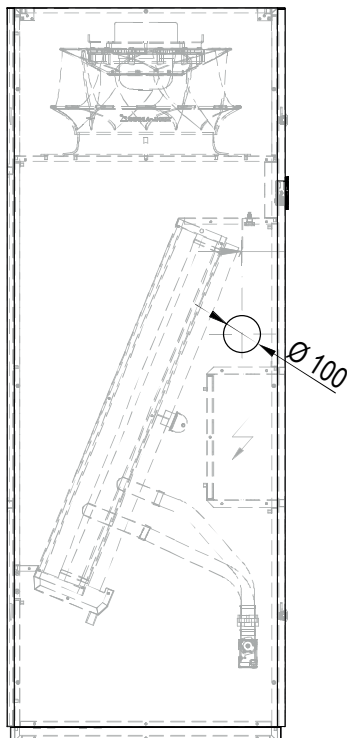

Vers. D

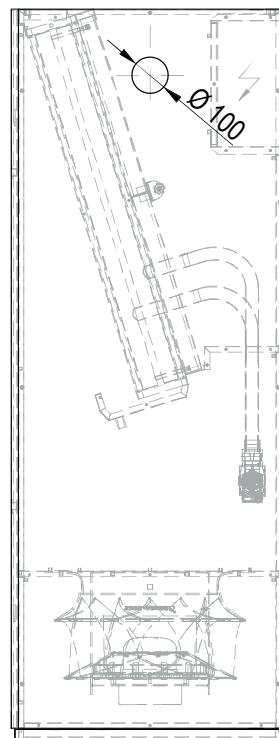

4.17 Humidifier (optional) (H)

4.17.1 Humidifier connection (optional)

The unit is designed to be supplied with water, sanitary preferably, using a suitable conduit provided with a interception shut-off valve, which has to be connected also to drain pipe in order to collect the condensation and excessive water.

Is recommended to use clean water to supply the unit (impurity has to be not bigger than 100micro) even if the humidifier is provided with a filter.

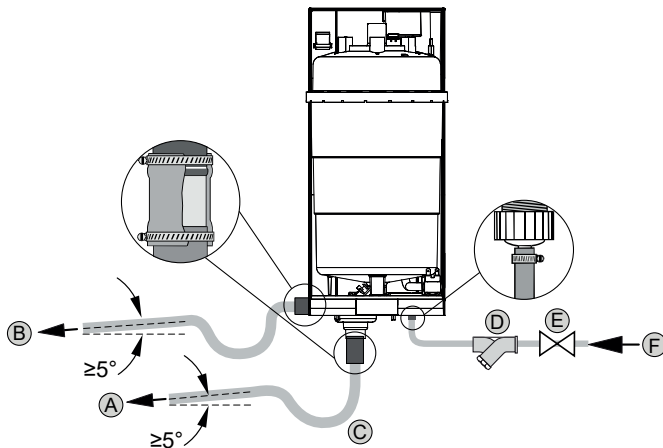

A	Exhaust
B	Steam production exhaust ≥ 25 kg/h
C	Siphon
D	Filter
E	Shut-off valve
F	Power supply



Is recommended to add a mechanical filter and a shut-off valve to hold back solid impurities.



The exhaust pipe has to be free, without backpressure and provided with a siphon immediately under humidifier connection.

4.17.2 Exhaust

Exhaust max. flow	~ 4 l/min
Exhaust water connection	32 mm
Exhaust min. interna \varnothing	45 mm

4.17.3 Power supply

Supply max. flow	~ 4 l/min
Supply water connection	$\frac{3}{4}$ "G M
Charge min. internal \varnothing (rigid or flexible pipe)	45 mm

The connection of drain water is realized using a plastic/rubber pipe (resistant up to 100°C), with internal section suggested of 32 or 40mm (DIN 19535, UNI 8451/8452 compliant).

The discharge junction is suitable for hot blade welder with discharge pipes in Polypropilene



Is suggest to limit to 4mt the steam transport pipe, in order to correct operation. The steam condensate pipe siphon has to be filled with water before start up the humidifier.

4.17.3 Steam production regulation

The steam production must be limited to 60-70% of maximum humidifier capacity to guarantee a longer lifetime of the device. To the access or modify the operating parameters refer to the humidifier manual, attached.

4.18 Electric connections: safety preliminary advices

The electrical cabinet is located inside on the front of the unit where are placed also the cooling circuit components. To access please remove the frontal panel.



The electric connection has to be performed following the electrical diagram attached to the unit following the local and international norms.



Ensure that the power supply line is sectioned upstream of it.
Ensure that the sectioning device is locked and that on the drive handle is positioned the advice to not operate.



Verify the power supply corresponds to the unit nominal datas (tension, phases, frequency) provided on the wiring diagram and on the Identification Tag attached on the unit.



The power supply cables must be protected upstream against the effect of short circuits and overload by a suitable device complying with the regulations and norms in force.



Ensure that the power supply cable section are suitable to the capacity of the unit and safety devices taking into consideration all the factors can influence it (temperature, isolation type, length, etc.)



The electrical power supply has to respect the mentioned limits; otherwise the warranty will be immediately decay.



Make all the ground connections required by the legislation and norms in force.



Before to starts any operation ensure the power supply is disconnected.



The electrical line and unit external safety devices has to be dimensioned in order to guarantee the power supply tension to the maximum operation conditions provided to the wiring diagram.



In presence of IT power supply lines the Manufacturer has to release, after checking, the connection authorization.

4.19 Electrical data



Refer to the electrical data provided on the wiring diagram.



The supply voltage cannot suffer variations higher than $\pm 10\%$ and the unbalance between phases less then 1% (EN 60204 norm). If those tolerances are not respected please contact the technical department of the Manufacturer. The unit use with voltage different that designed will make decay the warranty.

4.19.1 DXi.A electrical data

Model		61	111	121	151	181	201	251	321
Power supply	V/~ /Hz	400/3/50+N+PE							
Control circuit	V/~ /Hz	24/1/50							
Auxiliary circuit	V/~ /Hz	24/1/50							
Compressor's supply	V/~ /Hz	400/3/50							
Line section	mm ²	2,5	2,5	2,5	2,5	4	4	6	6
PE section	mm ²	2,5	2,5	2,5	2,5	4	4	6	6

Model		381	392	472	491	531	532	631	652
Power supply	V/~ /Hz	400/3/50+N+PE							
Control circuit	V/~ /Hz	24/1/50							
Auxiliary circuit	V/~ /Hz	24/1/50							
Compressor's supply	V/~ /Hz	400/3/50							
Line section	mm ²	10	10	10	10	16	16	16	16
PE section	mm ²	10	10	10	10	16	16	16	16

Model		691	742	761	861	931	952	1021	1142
Power supply	V/~ /Hz	400/3/50+N+PE							
Control circuit	V/~ /Hz	24/1/50							
Auxiliary circuit	V/~ /Hz	24/1/50							
Compressor's supply	V/~ /Hz	400/3/50							
Line section	mm ²	16	25	25	25	25	35	25	35
PE section	mm ²	16	25	25	25	25	35	25	35

4.19.2 DX.A electrical data

Model		61	71	91	111	151	181	201	221	232
Power supply	V/~ /Hz	400/3/50+N+PE								
Control circuit	V/~ /Hz	24/1/50								
Auxiliary circuit	V/~ /Hz	24/1/50								
Compressor's supply	V/~ /Hz	400/3/50								
Line section	mm ²	2,5	2,5	2,5	2,5	2,5	4	4	4	6
PE section	mm ²	2,5	2,5	2,5	2,5	2,5	4	4	4	6

Model		251	301	321	322	391	392	431	442	451
Power supply	V/~ /Hz	400/3/50+N+PE								
Control circuit	V/~ /Hz	24/1/50								
Auxiliary circuit	V/~ /Hz	24/1/50								
Compressor's supply	V/~ /Hz	400/3/50								
Line section	mm ²	6	6	6	10	6	10	10	10	10
PE section	mm ²	6	6	6	10	6	10	10	10	10

Model		472	511	512	531	602	672	742	761
Power supply	V/~ /Hz	400/3/50+N+PE							
Control circuit	V/~ /Hz	24/1/50							
Auxiliary circuit	V/~ /Hz	24/1/50							
Compressor's supply	V/~ /Hz	400/3/50							
Line section	mm ²	16	16	16	16	16	25	25	25
PE section	mm ²	16	16	16	16	16	25	25	25

Model		762	772	841	862	982	1002	1102	1252
Power supply	V/~ /Hz	400/3/50+N+PE							
Control circuit	V/~ /Hz	24/1/50							
Auxiliary circuit	V/~ /Hz	24/1/50							
Compressor's supply	V/~ /Hz	400/3/50							
Line section	mm ²	25	25	25	25	35	35	35	35
PE section	mm ²	25	25	25	25	35	35	35	35



The electrical data could change without any advice; It is necessary refers always to the wiring diagram provided with the unit.

4.20 Power supply connection

The unit must be powered with a 5-poles cable (3phases+N+PE) if the power supply is 400V/3ph/50Hz; on request is possible to provide the unit with special power supply (refer to Identification Tag and wiring diagram).

Connect three phases and the neutral to prepared terminals of the main switch and the earth wire to its corresponding terminal; use a power supply cable of adequate section and as short as possible in order to avoid voltage drops.

Protect the power supply cable with an automatic switch of appropriate size and features. The Power supply cable section and the size of automatic switch can be detected on the wiring diagram attached to the present Manual.

The entrance of power supply cable is indicated on the technical drawing of the unit attached to the present Manual, the entrance must be adequately protected in accordance with local norms in force.



If the power supply cable comes from the top of the unit is advisable to make a bend break before plugging it into the connection.

Perform a visual check before to make any intervention on the electric circuit in order to avoid a transport damage; Particularly check every terminal screw, their tightening and the integrity of every cable isolation.

The conductors for the phases of the power supply cable must be connected to the free terminal in input to the general switch of the unit; the earth conductor must be fixed to the corresponding terminal or bar (identified with PE).

4.20.1 User's terminal board connection

A user terminal board is available with free contacts designed for:

- Generic alarm mode;
- Unit remote ON/OFF.

Inside of the electrical board are available a terminal where are available the digital and analogic signals for the unit operation.

The terminal configuration could change unit by unit so refer to the one represented on the wiring diagram attached to the present Manual.

4.20.2 Phases sequence in the power supply check

The unit's device rotation (compressors, fans, pumps, etc.) are checked and harmonized during the factory test performed by the Manufacturer (except for the unit with a special power supply or the units cannot be starts). Once the connection is made it is necessary to check if the phases are rightly connected, on this purpose make sure all electric devices rotation is in right side.
 For three phases units if one component rotation is wrong is must be assumed that every component rotation is wrong, so two phases must be inverted in the main switch terminal.



To avoid connection errors other conductors belonging to the main switch must not be disconnected, in addition to the two involved in the operation.

4.20.3 IT systems compatibility (without ground connection) and TN systems with ground connection (DXi.A series)



Disconnect the internal EMC filter if a IT system converter has to be installed (supply system without ground connection or with ground connection to high resistance [higher then 30ohm]), otherwise the system will be connected to ground potential using the EMC filter condensers; this could be dangerous for the people and unit.
 Disconnect the internal EMC filter if a TN system with a ground connection has to be installed otherwise the converter will be damaged

When the internal EMC filter is disconnected if is not installed an external filter, the frequency converter do not meets the electromagnetic compatibility requirements.

To EMC disconnection remove the EMC screw.

4.20.4 Supply cable connection

- 1) Connect to ground the PE conductor on distribution schede.
- 2) Use an additional ground connection wire if the shielding is inadequate (lower than conductivity of phase conductor) and there is not a simmetric ground conductor inside the wire.

4.21 RS485 Serial interface

Supervision system connection (MODBUS-RS485 only suprevision system available).

This system allows control all the unit operation parameters by remote and allows also the possibility to change them.

It is necessary to respect the wiring polarity how shown below; The polarity inversion could cause a unit malfunction. The supervision system cable should be twisted type and shelded with 2 wire AWG20/22.

Unit is factory settled with serial address 1; if MODBUS protocol is used there is the possibility to ask the variables list to the Manufacturer.

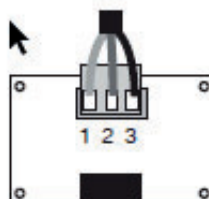
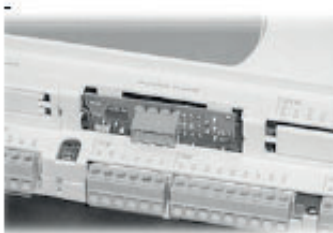

pin	significato meaning
1	GND
2	RX+/TX+
3	RX-/TX-

5. START UP

5.1 Preliminary checks

Before to start up the unit has to be necessary perform some electric, hydraulic and cooling checks.



Commissioning operations has to be performed following the previous mentioned indications.



Do not switch off the unit (temporary stop) using the main switch; this device has to be used only to disconnect the unit when a current is absent, for example when the unit is in OFF. Moreover, when the power supply is off the crankcase heaters are not powered with consequent danger of compressor rupture when the unit will be powered.

5.1.1 Before to start up



Malfunctions or damage can derive also by lack of attention during shipping and installation; before installing or starting up the unit check about refrigerant leak presence caused by capillaries rupture or gauges connections, cooling circuit pipes, transport vibrations, manumission or mistreatments on site.

- Check the right unit installation in accordance with advices in the present Manual;
- Check the electric connection and the terminal screw connections;
- Check the phases voltage (R S T) and the compliance with the Identification Tag;
- Check the unit ground connection;
- Check the refrigerant leaks, eventually using an apposite device;
- Check the oil leaks near the compressors or along the cooling circuit;
- Check the pressure of the cooling circuit using the gauges installed (if presents) or service gauges;
- Check the closing of all service outlets;
- Check the correct supply of the crankcase heaters (if presents);
- Check that all the hydraulic connection are performed correctly and that all the indications on the plates are respected;
- Check that the system has been properly vented;
- Check the unit internal fluid temperature, they must respect the operation limits;
- Before to start up the unit check that every panel is in right position and well closed;
- Check the opening of all the circuit shut-off valve.



Do not modify any unit connection, otherwise the warranty immediately decay.



If present, the crankcase heaters must be switch on at least 12 hours before unit starts (preheating period) closing the main switch (the heaters are automatically supplied when the switch is closed). The heaters are working correctly if after few minutes the carte temperature will be 10/15°C higher than ambient temperature.



In case of crankcase heaters presence, during the preheating period is important to check if on the unit display is present the word OFF or if the unit is in stand-by mode. In case of accidental start (before of preheating time) the compressors could be seriously damaged and the warranty immediately decay.

5.2 First start up

Before the first unit start up or after a long break it is necessary to check the consistency of the microprocessor setting values with the planned operation conditions.

To switch ON the unit rotate the main switch in ON position in order to supply it.



Ensure the unit is Switched OFF from the keyboard.



Wait at least 12 hours before to switch on the unit so as to allow the crankcase heater to heat the oil in the compressors.

Once powered the unit, after a short controller auto-test period, it is necessary to press ON/OFF key switching into ON; after that in accordance with settled parameters and thermally-hygro thermic conditions detected, all the unit devices will switch on.



Check the fans and compressors rotation if the power supply is of three phases; if the rotation is wrong will be necessary to invert two of three phases on the main switch terminals.

Once the unit reaches a nominal operation, the technician in charge must detect the operating parameters. The data must be registered on the First Start Up Report, attached to the present Manual.



A copy of First Start Up report fulfilled has to be transmitted to the Manufacturer in order to make the Warranty valid.



During first start up operations the technician in charge must verify that control and safety devices properly work.



The unit first start up must be performed by an expert cooling technician authorized by the manufacturer.

5.3 Operation checks

Checks the fans rotation; if is wrong turn off immediately the main switch and invert two of three phases of the main switch in order to invert the motor rotation.

After few hours of nominal working check the sight glass, it must be of green color, in case of the glass is yellow humidity could be present inside the circuit; it will be necessary to dehydrating the circuit (operation performed by expert technicians).

Checks also if on the sight glass air bubbles are presents, if yes it means that the refrigerant charge is insufficient; put some refrigerant inside the circuit.

However, the presence of some steam bubble is permitted.

5.4 Safety valves

The external safety valves output connections installed on the unit are provided with a threaded connection in order to be connected to an exhaust duct, when the project or the local regulations and norms expect.

If expected, the valves must be individually conveyed using metallic pipes, up to an area where the discharged refrigerant cannot cause damage to people or things.



The safety valves output refrigerant has high temperature and pressure if fast discharged; the flow could be dangerous for person or thing directly invested.



The valve opening is accompanied by a noise whose intensity could cause damages, also permanent, to the people immediately near the unit.

The tubes must be a diameter not smaller than safety valves discharge connection; the refrigerant pressure drop must be as low as possible to avoid the valves discharge flow reduction.

The valve discharge must be done to an adequate distance from other equipment, systems or ignition sources; the discharged refrigerant must not accidentally enter into buildings.

In any case the safety valve discharge must be done in accordance with regulations and laws in force.

5.5 Safety devices calibration

	OFF (barg)		ON (barg)
High pressure safety valve			43,4 (open)
High pressure gauge	Unit with Rotary compressor	39,1	33
	Unit with Scroll compressor	42	35
Low pressure gauge	4		6

6. USE

6.1 Electronic microprocessor control description and use

The controller is composed by:

- A control electronic card with the terminals for transmission of functioning parameters and the drive of control devices;
- User interface card with programming keys and graphic display to check the operation modes and the alarm messages; the card manages the different devices which are installed in the unit, following the operation variables values; In this way the card cans realizes the following main functions:

- Unit ON/OFF from the keyboard or remote;
- Alarm and risk situation management;

The use interface display of controller cans shows also the folowing information:

- Regulation parameters values settled;
- Operating variables values;
- Analogic and digital inputs and outputs conditions;
- Unit operation mode
- Alarm and risk indication.

Possibility to interfacing with BMS system.

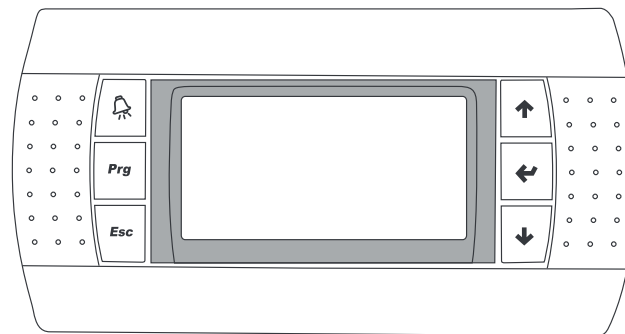

6.2 Remote control description

6.2.1 Dimensions

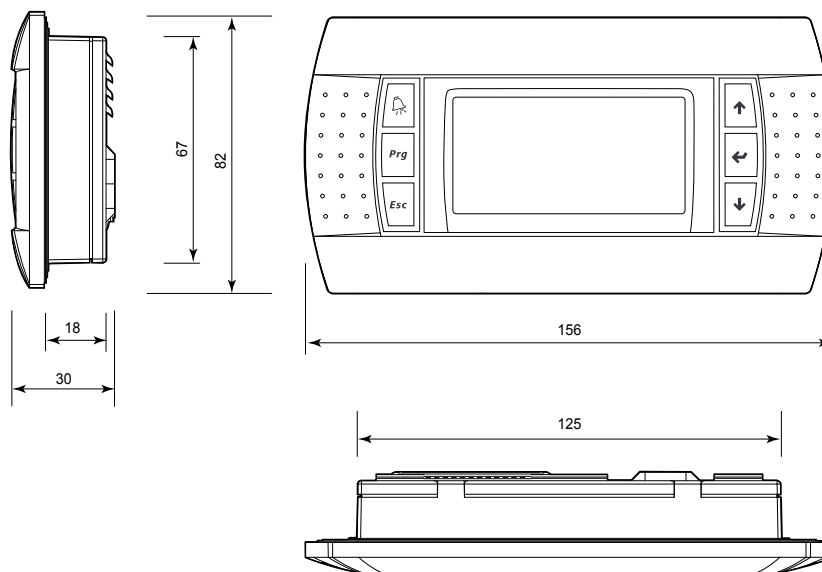

6.2.2 Electrical connection

Connect the phone wire is coming from the card to the back terminal suitable connector.

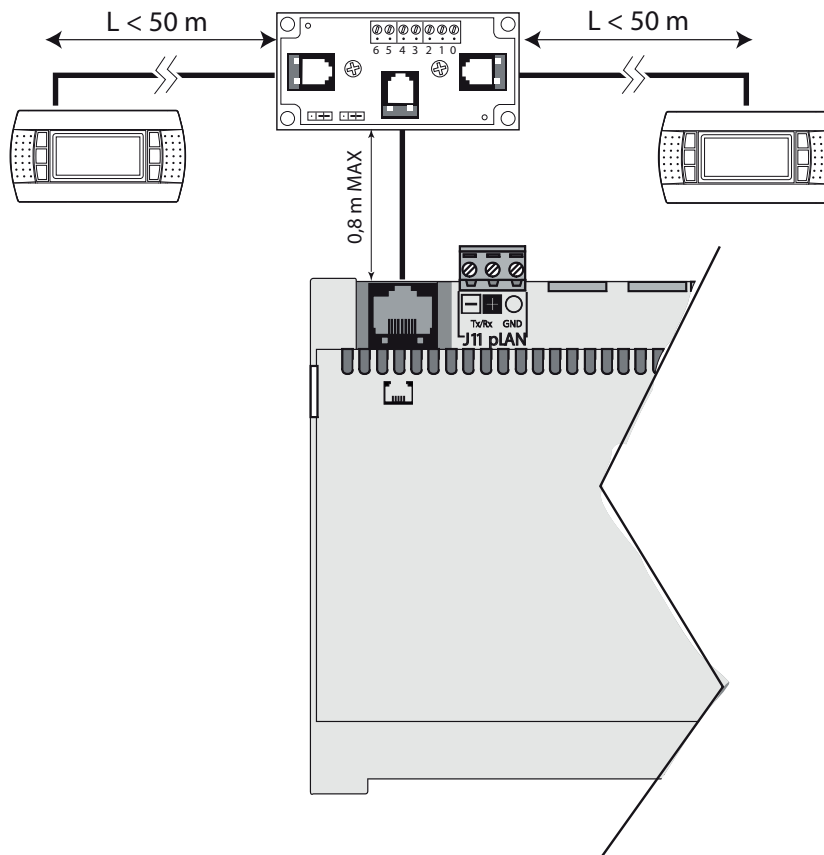

For the control panel electrical connection refer to the wiring diagram provided with the unit.



If a wiring Controller/terminal trouble occurs, the failure communication between the controller and remote terminal will be displayed with “noL” (no Link) error message.

6.3 Keys function

	Allows the entrance to alarm display with manually reset possibility.
Prg	Allows the entrance to main Menu.
Esc	Back to the previous or standby mask.
	Scrolling the Menu or the values to be modified.
	Enter: Allows to enter in the parameter to be modified or the entrance to the selected menu.
	Scrolling the Menu or the values to be modified.

6.4 User interface

The below picture is the standby visualisation.

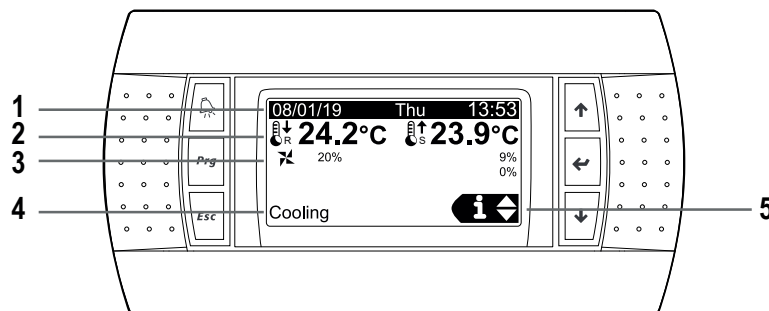

1	Date and hour																																												
2	Regulation probes (SUction air “R” and discharge air “S”). In case of humidity enabled, the temperature value is alternated to humidity one.																																												
3	Compressors mode; thermoregulation request and actual discharge fan speed.																																												
4	<table border="1"> <tr> <td colspan="2">Unit mode:</td> </tr> <tr> <td>Stand by</td> <td>Only fan active, no cooling required.</td> </tr> <tr> <td>Off by alarm</td> <td>Unit OFF for serious alarm</td> </tr> <tr> <td>Off by BMS</td> <td>Unit OFF from supervision control</td> </tr> <tr> <td>Off by sched</td> <td>Off by sched</td> </tr> <tr> <td>Off by DI</td> <td>Unit OFF by digital input</td> </tr> <tr> <td>Off by keyboard</td> <td>Unit OFF by keyboard</td> </tr> <tr> <td>Manual mode</td> <td>Unit with at least one device in manual mode</td> </tr> <tr> <td>Start-up</td> <td>BLDC compressor ON with start-up speed</td> </tr> <tr> <td>Shutdown</td> <td>Power decrease after switch OFF request</td> </tr> <tr> <td>Safety off</td> <td>Off safety</td> </tr> <tr> <td>High Delta P</td> <td>BLDC compressor wait about pressure reduction for start</td> </tr> <tr> <td>Cooling</td> <td>Cooling ON unit</td> </tr> <tr> <td>Restarting</td> <td>BLDC compressor trying to restart</td> </tr> <tr> <td>Wait timings</td> <td>Waiting, compressors OFF for timing</td> </tr> <tr> <td>Oil recovering</td> <td>BLDC oil recovery function enabled</td> </tr> <tr> <td>Off by network</td> <td>Unit OFF by duty-standby function</td> </tr> <tr> <td>Destabilization</td> <td>Oil recovery function enabled using destabilisation system</td> </tr> <tr> <td>Dehumidification</td> <td>Dehumidification enabled</td> </tr> <tr> <td>Pump down</td> <td>Pump down enabled mode</td> </tr> <tr> <td>Heating</td> <td>Heating ON unit</td> </tr> <tr> <td>Freecooling</td> <td>Freecooling ON unit</td> </tr> </table>	Unit mode:		Stand by	Only fan active, no cooling required.	Off by alarm	Unit OFF for serious alarm	Off by BMS	Unit OFF from supervision control	Off by sched	Off by sched	Off by DI	Unit OFF by digital input	Off by keyboard	Unit OFF by keyboard	Manual mode	Unit with at least one device in manual mode	Start-up	BLDC compressor ON with start-up speed	Shutdown	Power decrease after switch OFF request	Safety off	Off safety	High Delta P	BLDC compressor wait about pressure reduction for start	Cooling	Cooling ON unit	Restarting	BLDC compressor trying to restart	Wait timings	Waiting, compressors OFF for timing	Oil recovering	BLDC oil recovery function enabled	Off by network	Unit OFF by duty-standby function	Destabilization	Oil recovery function enabled using destabilisation system	Dehumidification	Dehumidification enabled	Pump down	Pump down enabled mode	Heating	Heating ON unit	Freecooling	Freecooling ON unit
Unit mode:																																													
Stand by	Only fan active, no cooling required.																																												
Off by alarm	Unit OFF for serious alarm																																												
Off by BMS	Unit OFF from supervision control																																												
Off by sched	Off by sched																																												
Off by DI	Unit OFF by digital input																																												
Off by keyboard	Unit OFF by keyboard																																												
Manual mode	Unit with at least one device in manual mode																																												
Start-up	BLDC compressor ON with start-up speed																																												
Shutdown	Power decrease after switch OFF request																																												
Safety off	Off safety																																												
High Delta P	BLDC compressor wait about pressure reduction for start																																												
Cooling	Cooling ON unit																																												
Restarting	BLDC compressor trying to restart																																												
Wait timings	Waiting, compressors OFF for timing																																												
Oil recovering	BLDC oil recovery function enabled																																												
Off by network	Unit OFF by duty-standby function																																												
Destabilization	Oil recovery function enabled using destabilisation system																																												
Dehumidification	Dehumidification enabled																																												
Pump down	Pump down enabled mode																																												
Heating	Heating ON unit																																												
Freecooling	Freecooling ON unit																																												
5	Quick access Menu																																												

6.5 Password settings

There are three different password levels:

- User: allows only to read all the parameters;
- Service: allows to read all the parameters and to modify some;
- Manufacturer: allows to read and modify any parameter.

In this Manual is describe the only user password use.

6.5.1 Masks loop and organization

Inside every menu the masks are arranged in loop; with and keys is possible to switch through them. Every mask is characterized by a 4-digit code to the top right of the screen and it is composed as:

- 1° digit: Main Menu code
- 2° digit: Secondary Menu code
- 3° e 4° digits: Mask code

6.6 Quick access Menu

From main screen, using and keys is it possible to slide the areas of quick access Menu.

PTo enter on the area press key. Is it possible to display the parameters without any password.

The quick menu areas are:

	INFO: Contains the actual unit operating functions in synoptic form, inputs state and outputs, serial devices and software information.
	ON/OFF: Allows to switch ON/OFF the unit.
	SET POINT: Allows to change the temperature, humidity and fan set points.

6.6.1 Menu INFO

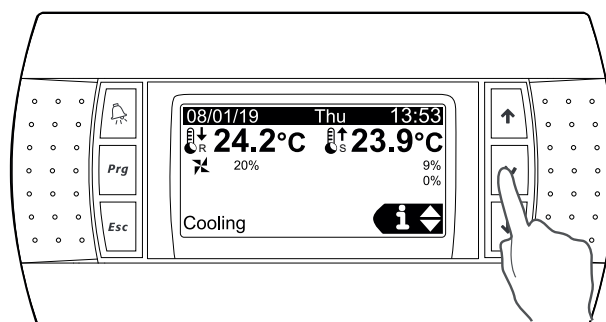

<p>Info - Inv.circl1 Z001</p> <p>Out: 0 0.0 DAR 0.0 T.disp: 0.0 STATUS: DeltaP: 0.0 OFF T.suc: 0.0 0.0 DAR 0.0</p>	<p>Compressor circ.1 condition (with inverter): intake and exhaust temperature, low and high pressure.</p>
<p>Info - Circuit 1 Z002</p> <p>Safety Timing Inverter comp.1 On-On: (0s) Min.On: (0s)</p>	<p>Compressor safety timing circ.1 (inverter).</p>
<p>IIInfo - Inv.circl2 Z003</p> <p>Out: 0 0.0 DAR 0.0 T.disp: 0.0 STATUS: DeltaP: 0.0 OFF T.suc: 0.0 0.0 DAR 0.0</p>	<p>Compressor circ.2 condition (with inverter): intake and exhaust temperature, low and high pressure.</p>
<p>Info - Circuit 2 Z004</p> <p>Safety Timing Inverter comp.2 On-On: (0s) Min.On: (0s)</p>	<p>Compressor safety timing circ.2 (inverter).</p>
<p>Info - EEV 1 Z005</p> <p>0% 0stp STATUS: Set: 0.0°C Suction SH: 0.0°C</p>	<p>Thermostatic valve condition - circ.1</p>
<p>Info - EEV 1 Z006</p> <p>Suct.P.: 0.0 bar Suct.T.: 0.0 °c Suction SH: 0.0 °c Dscg.P.: 0.0 bar Dscg.T.: 0.0 °c</p>	<p>Overheating condition circ.1</p>
<p>Info - EEV 2 Z007</p> <p>0% 0stp STATUS: Set: 0.0°C Suction SH: 0.0°C</p>	<p>Thermostatic valve condition - circ.s</p>
<p>Info - EEV 2 Z008</p> <p>Suct.P.: 0.0 bar Suct.T.: 0.0 °c Suction SH: 0.0 °c Dscg.P.: 0.0 bar Dscg.T.: 0.0 °c</p>	<p>Overheating condition circ.2</p>
<p>Info - Source 2 Z009</p> <p>PREVENT ACTIVE Disc.press: 19.9 bar Setpoint: 18.0 bar Source: 0.0%</p>	<p>Shown when the PREVENT function is activated.</p>
<p>Info - Humid. Z012</p> <p>Curr.request: 0%</p> <p>On/Off: 0</p>	<p>It allows to consult the information on the humidification mode.</p>
<p>Info - Humid. Z013</p> <p>Curr.request: 0%</p> <p>Dehum.Running: 0</p> <p>Rel. Abs. [%] [gH2O/kg]</p> <p>Hum. 21.4 3.32 Set. 5.0 0.92</p>	<p>It allows to consult the information on the dehumidification mode.</p>

<p>Info - Freecool. Z014</p> <p>Damper/valve on: 0 Freec.temp.: 23.1°C Freec.request: 0.0%</p>	Shown when the FREECOOLING function is activated.
<p>Info - Hot Req. Z016</p> <p>Request hot valve: 0% Request heaters: 81%</p>	It allows to consult the information on the heating mode.
<p>Info - Heater. Z018</p> <p>Heater 1: 0 Heater 2: 0</p>	It allows you to check whether the digital outputs of the heaters are active.
<p>Info - Heater. Z019</p> <p>16:32 FRI 23/03/2019</p> <p>Sched. is not running</p>	View only screen; it allows you to check some operating data of the unit.
<p>Info - Fan Z020</p> <p>Curr.speed: 700rpm Curr.request: 0% Min speed: 40.0% Max speed: 70.0% Power out: 4.0W Drive temp.: 40.0°C</p>	Provides information on operating fans. Possibility to choose which ones to activate from the E008 mask.
<p>Info - Fan2 Z024</p> <p>Curr.speed: 0rpm Curr.request: 0% Min speed: 40.0% Max speed: 70.0% Power out: 4.0W Drive temp.: 40.0°C</p>	Provides information on operating fans. Possibility to choose which ones to activate from the E028 mask.
<p>Unit Conf. Z101</p> <p>Return temperature (U01)</p> <p>Value: 24.2°C Offset: 0.0°C Type: NTC</p>	Provides information on the input temperature of the machine.
<p>Unit Conf. Z102</p> <p>Supply temperature (U02)</p> <p>Value: 23.2°C Offset: 0.0°C Type: NTC</p>	Provides information on the output temperature of the machine.
<p>Unit Conf. Z103</p> <p>Return humidity (U04)</p> <p>Value: 48.4% Offset: 0.0% Type: 0-10V Mimum: 10.0% Maximum: 90.0%</p>	Provides information on the input humidity value of the machine. It can be enabled by the Ga10 mask.
<p>Unit Conf. Z105</p> <p>Freecool. temperature (U06)</p> <p>Value: 23.1°C Offset: 0.0°C Type: NTC</p>	Provides information on freecooling settings. It can be enabled by the Ga07 mask.
<p>Unit Conf. Z106</p> <p>Fan diff. press. (U05)</p> <p>Value: 7166.9 m3/h Mimum: 0.0 m3/h Maximum: 7589.5 m3/h</p>	Provides information on the differential pressure level of the fans. It can be enabled by the Ga10 mask.
<p>Unit Conf. Z121</p> <p>External temperature for compensation (U07)</p> <p>Value: 20.8°C Offset: 0.0°C Type: NTC</p>	Provides information on temperature set point compensation settings.

<p>Unit Conf. Z123 Air pressure filter (ID03) Value: Not Active Offset: NC Type: Closed</p>	<p>Provides information on the conditions of the filters.</p>
<p>Info - IO Z201 Start/Stop (ID01) Value: Active Logic: NC HW valve: Closed</p>	<p>On/Off digital input condition</p>
<p>Info - IO Z210 Humidifier Alarm (ID07) Value: Not Active Logic: NC HW valve: Closed</p>	<p>Digital input condition of humidifier alarm.</p>
<p>Info - IO Z211 Heaters overload (ID04) Value: Not Active Logic: NC HW valve: Closed</p>	<p>Thermal state electrical heaters 1 and 2. Possibility to enable them with sigital input from Ga10 mask.</p>
<p>Info - IO Z212 Smoke/Fire detector (ID05) Value: Not Active Logic: NC HW valve: Closed</p>	<p>Display of fire/smoke alarm status (from digital input). It can be enabled by the Ga09 mask and be in a single input together with the flood alarm.</p>
<p>Info - IO Z213 Water flooding switch (ID06) Value: Not Active Logic: NC HW valve: Opened</p>	<p>Dislpay Flood alarm condition (from digital input). It can be enabled by the Ga09 mask.</p>
<p>Info - IO Z223 Air flw./Ovid.main fan (ID02) Value: Not Active Logic: NC HW valve: Closed</p>	<p>Display the condition of the air flow switch & main fan thermostat.</p>
<p>Info - IO Z323 Open hot valve (N002) Value: Not Active Logic: NO HW valve: Opened</p>	<p>Display of the digital outputs condition of the hot valve or the electrical heater.</p>
<p>Info - IO Z324 Close hot valve (N003) Value: Active Logic: NO HW valve: Closed</p>	<p>Display of the condition of the digital outputs of the hot valve or the electrical heater.</p>
<p>Info - IO Z329 Supply fan (N001) Value: Active Logic: NO HW valve: Closed</p>	<p>Display of the condition of the main fan</p>
<p>Info - IO Z330 On/Off analogic hum. (N008) Value: Active Logic: NO HW valve: Closed</p>	<p>Display of the digital output condition for the humidifier on/off</p>
<p>Info - IO Z331 Freecooling (N009) Value: Not Active Logic: NO HW valve: Opened</p>	<p>Display of the freecooling digital output. It can be enabled by the Ga11 mask.</p>

Info - IO Z332 On/Off dehumidifier (NO10) Value: Active Logic: NO HW valve: Closed	Display of On/Off for external dehumidifier output.
Info - IO Z333 On/Off source (NO11) Value: Active Logic: NO HW valve: Closed	Display of On/Off for remote condenser output.
Info - IO Z408 Humidifier (Y02) Value: 100.0% Type: 0-10V	Display the conditions of the analogical humidifier
Info - IO Z409 Hot Valve (Y03) Value: 0.0% Type: 0-10V	Display the conditions of the hot valve
Info - IO Z410 Freecooling (Y03) Value: 0.0% Type: 0-10V	Display analogical freecooling output
Working hours Inv.comp,circ.1 Z500 Hours: 0h Next thresh.: 30000h Reset hours: NO Dev.Status: OFF N.Start: 45 Reset N.start: NO	Compressor counter circuit 1.
Working hours Inv.comp,circ.2 Z503 Hours: 0h Next thresh.: 30000h Reset hours: NO Dev.Status: OFF N.Start: 25 Reset N.start: NO	Compressor counter circuit 2
Working hours Heaters 1 Z506 Hours: 0h Next thresh.: 99000h Reset hours: NO Dev.Status: OFF	Heater 1 hour counter
Working hours Heaters 2 Z507 Hours: 0h Next thresh.: 99000h Reset hours: NO Dev.Status: OFF	Heater 2 hour counter
Working hours Unit working Z512 Hours: 6h Next thresh.: 99000h Reset hours: NO Dev.Status: ON	Unit operation hour counter.

6.6.2 Menu ON/OFF

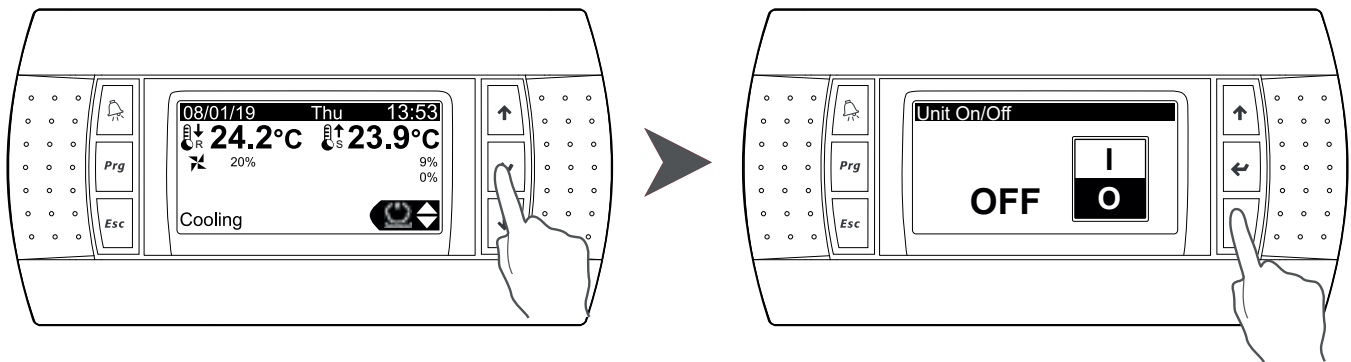

To switch ON/OFF the unit enter to ON/OFF Menu and using **↑** and **↓** keys move the cursor
Press **←** to confirm.

6.6.3 Menu SET

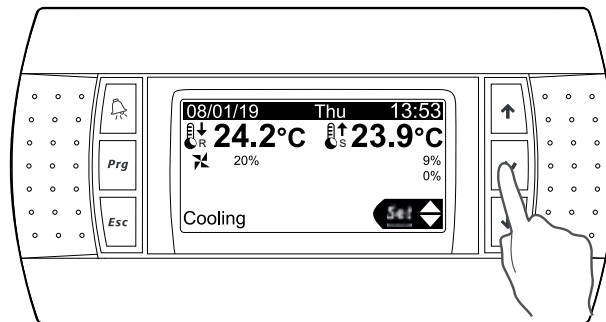

To enter in SET menu use **↑** and **↓** and press **←** key to confirm.
Can be displayed some set-point masks move through the masks using **↑** and **↓** keys.

SCHEDULER ST00 SET POINT ACTIVE Supply : 20.0°C Return : 23.0°C Humidif. : 30.0 % Dehumidif. : 70.0 % Diff.press. : 300.0 Pa	Displaying of scheduler enable set-point.
SCHEDULER ST00a SET POINT ACTIVE Sp. : 13000.0 m3/h Source max speed: 90.0 %	Displaying of condenser speed and scheduler enabled set-point.
Set point ST03 Return regulation Setpoint: 23.0°C	Return temperature set-point setting.
Set point ST04 Supply air low limit Setpoint: 20.0°C	Discharge temperature set-point setting.
Set point ST05 Fan speed: AUTO	Fan speed regulation setting.
Set point ST07 Humidification Setpoint: 30%	Humidity set-point setting.

6.7 Main Menu

Regardless of the mask you are in, pressing **Prg** key is possible to enter to Main menu using the password.

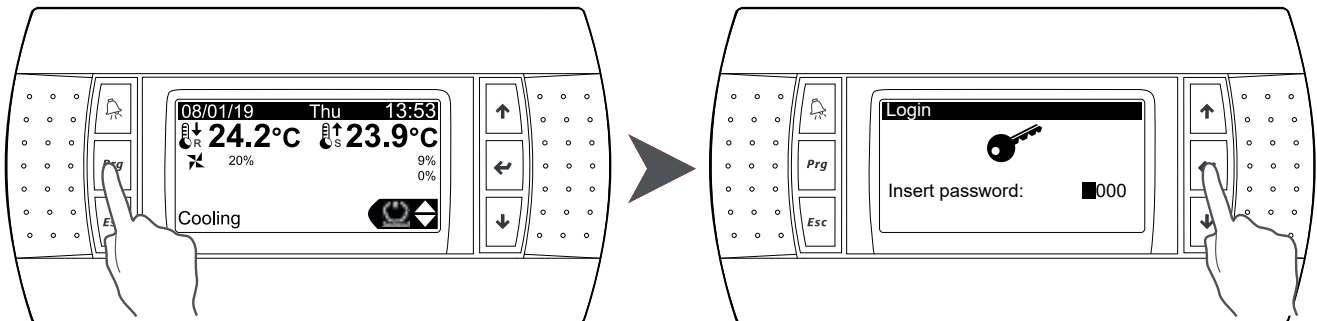

Select the value using **↑** and **↓**, keys than pres **↵** to confirm.

6.7.1 Main menu icons

	A. Compresseur (Not disponible)
	B. ExV (Non disponible)
	C. Power+ (Non disponible)
	D. Source (Not disponible)
	E. Ventilation
	F. CPY
	G. Réglages unités
	<ul style="list-style-type: none"> Configuration Régulation
	H. Alarmes
	I. Autres réglages
	<ul style="list-style-type: none"> Date / heures Langue Réseau Pwd Change Inizialization
	L. Logout

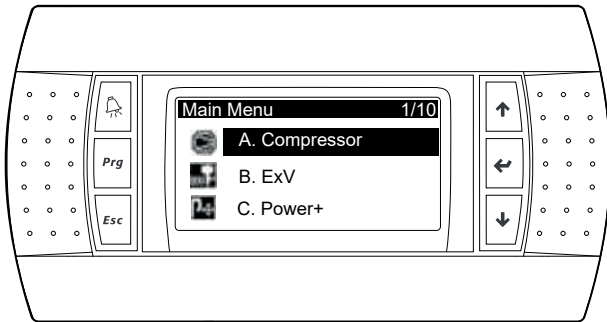

Compressor parameters setting (manufacturer password)

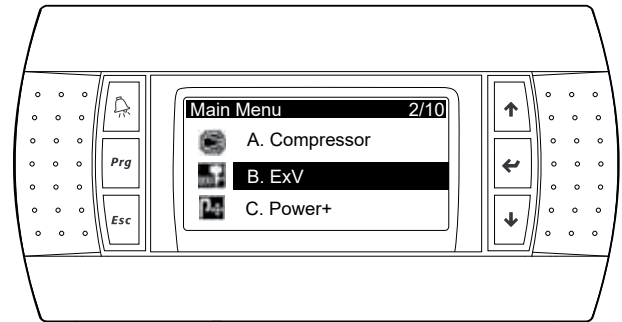

Thermostatic parameters setting (manufacturer password)

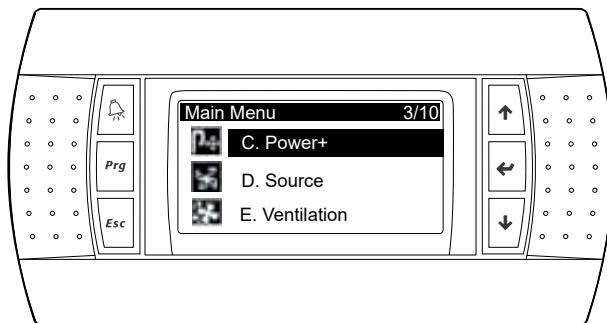

Inverter connected in serial line parameter setting (manufacturer password)

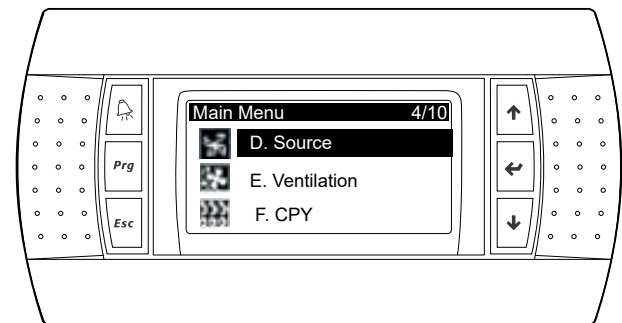

Remote condenser parameters setting (manufacturer password)

6.7.2 Menu Ventilation

To enter in fans menu use **Prg**, than, using **↑** and **↓** s keys is possible to select E.Fans menu, than press **←** to confirm.

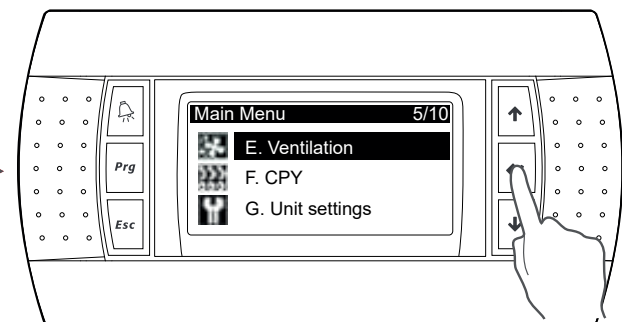
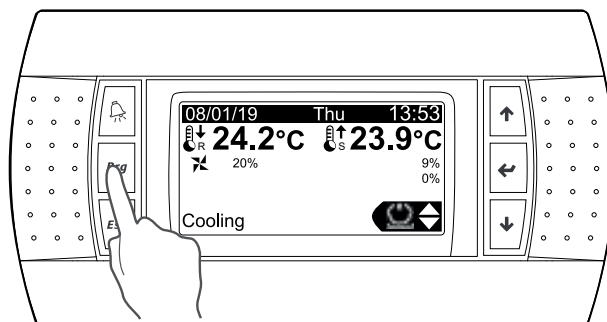

It will be possible the visualization of some masks referred to the fans and their parameters.

Supply fan E001 Type: EC Min speed(%): 40.0% Max speed(%): 70.0% Manual/Dehum.speed: 20.0%	Displaying the fans speed (min e max) and the dehumidification mode.
Supply fan E002 Limit speed Min speed(%): 20.0% Time startup: 60 s Time shutdown: 30 s	During the switch ON and OFF the fans are maintained to a constant speed for a settable time; in this masks is possible to visualize the set time.
Supply fan E003 Fan enabled: [v] Num.of fans: 2 Fan 1 online: [] Fan 1 online: []	Displaying the enabled fans, it is possible to enable to 4 fans in serial mode.

6.7.3 Menu CPY

To enter in CPY menu press **Prg** key, then **↑** and **↓** to select the F.CPY menu and press **←** to confirm.

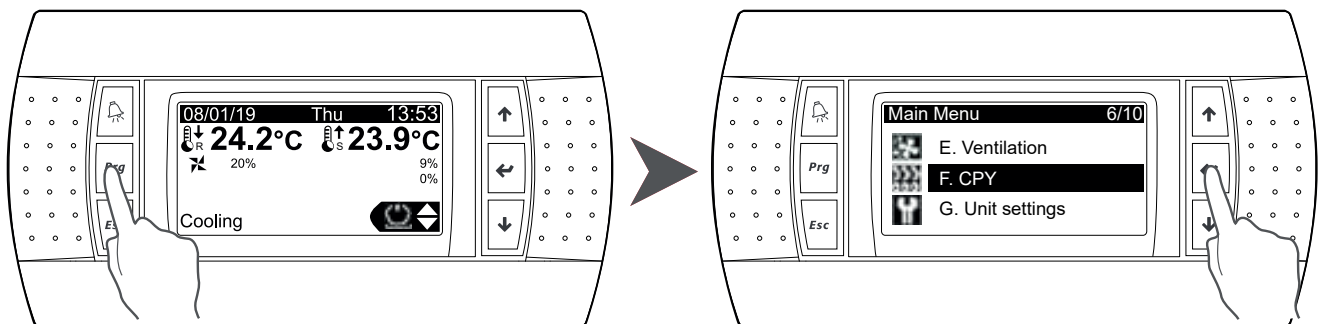

CPY F001 CPY Enable: [] Only if the humidity probe is enabled	Allows the visualization to check if the humidifier management card is enabled.
---	---

6.7.4 Menu Unit settings

Inside of the menu "Unit settings" there are two submenu: "configuration" e "regulation".

To enter in these menus, from "Unit settings" using **↑** and **↓** keys select the desire one than press **←** key to confirm.

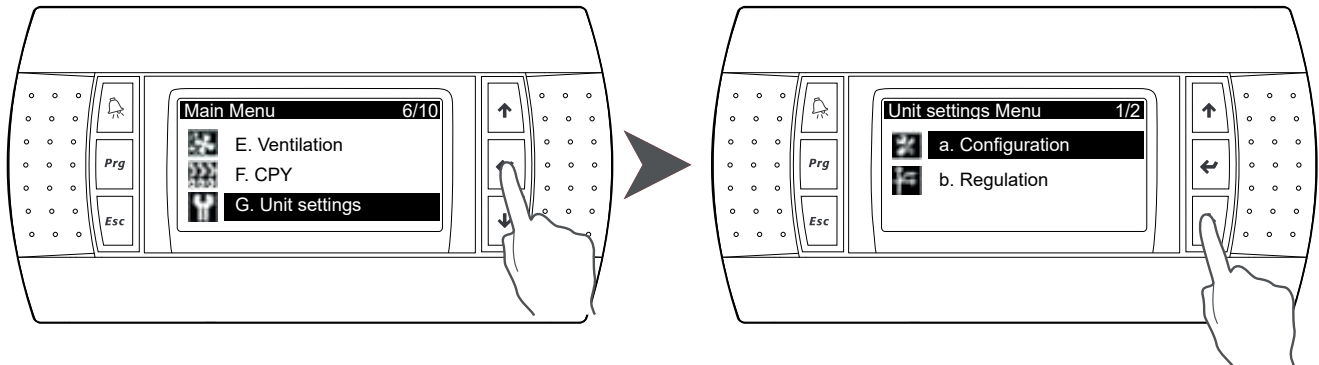

Unit config. Ga00 Unit Configuration: DX		Indicates the cooling type. In this case Chilled Water, water cooled units.
Unit config. Ga01 Compressors/circuits configurations: DX UNIT\MEDIUM TWO CIRCUITS C1: INV*ON/OFF C2: INV*ON/OFF		
Unit conf.funct. Ga07 Freecooling: [] Source: [] Humidification: [v] Dehumidification: [] Heating: REHEAT+INTEGR		Allows some functions enable. Using the user password allows the visualization of those enabled.
Unit conf.funct. Ga08 External setpoint: [] Compensation sp.: [] Control delta T.: []		Allows the visualization of some information of set point compensation.
Unit conf.en.I0 Ga09 External setpoint: [] Return humidity: [v] Diff.pressure: [] Freecooling temp.: [] Overload heater: [v] Al.fire/smoke: [v] Al.water flooding: [v]		Allows to configure the enabled functions management.
Unit conf.en.I0 Ga12 Al. fire/smoke series: [v] Al. w.flooding series: [v]		Allows to enable the digital inputs with the shown functions.
Unit conf.en.I0 Ga13 Open hot vlv./heater1: [v] Close hot vlv./heater2: [v] Type dout heat.: Heater		Heaters digital outputs status configuration.
Unit conf.en.I0 Ga14 Ext.air compens.: [] Warning: [] Freecool.On/Off: [] Hot vlv/Cold vlv/Hum: [v] Type analogic output: Cold valve		Analog or digital outputs enabled configuration.

Unit conf.en.IO (Y03) Hot vlv/Cold vlv/FC Cold valve Unit conf.en.IO Dehumi. On/Off: Unit conf.en.IO Emergency Ventilation Enable: Unit config.	Ga16 [] Ga20 [] Ga23 [] Ga24	Analog outputs configuration as selected function. Digital output enabling as dehumidification. Enabling "emergency ventilation" function.
Main mask info: Supply temp./Ret.Hum. Time change: Unit config. Serial probe Enable serial probe for return air temp. and humidity: Unit config.	7 s Ga25 [] Ga28	Selection the probe type on the main mask. Temperature serial probe configuration. Floating valve opening timing setting (2 or 3 points).
Air filter switch alarm delay: Unit config.	60s Ga44	Filter alarm lag setting.
Enable On/Off by supervisor: Status: Unit config. Import/Export: IMPORT Memory type: INTERNAL FLASH MEMORY File name: EXPORT_00 Confirm:	NO Off Ga99	Supervision ON/OFF enabling. Configuration of parameter file import/export.

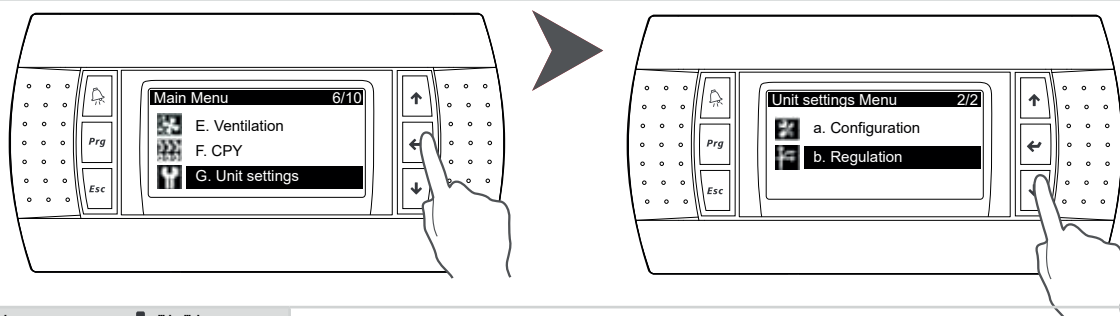

Unit regulation Temp.Regulation: RETURN + SUP.LIM Start unit delay: Unit regulation Return Regulation Min.setpoint: Max.setpoint: Supply Regulation Min.setpoint: Max.setpoint:	Gb01 ↓ 10s Gb02 10.0 °C 40.0 °C 0.0 °C 35.0 °C	Regulation mode setting. Set point min/max limits configuration.
---	---	---

Unit regulation Gb12		
Fan Regulation Kp: 6.0 Ti: 120s		PI fan displaying / settings.
Unit regulation Gb17		
DZ Fan: 0.0°C		PI fans neutral zones displaying / settings.
Unit regulation Gb20		
Comps./cooling coil Kp: 8.0 Ti: 120s		PI cold valve regulator displaying / settings.
Unit regulation Gb21		
DZ Cooling: 0.0°C		PI cooling neutral zones displaying / settings.
Unit regulation Gb22		
Supply air low limit regulation Kp: 6.0 Ti: 80s		PI discharge temperature regulation displaying / settings.
Unit regulation Limit max. dead zone Gb23		
Fan: 0.5°C		PI neutral zones limit settled displaying / settings.
Cooling: 0.5°C		
Unit regulation Gb24		
Humidification Kp: 6.0 Ti: 80s		Allows to display / set the parameters for humidifier function regulation.
Unit regulation Rehating heaters Gb32		
Rehating: Setpoint offset: Current set: Step delay:	2 STEPS 5.0°C Return 60s	Heaters regulation type displaying / settings.
Unit regulation Rehating PID heaters Gb36		
Kp: Ti: Td:	8.0 60s 0s	Heaters PID displaying / settings.
Unit regulation Temperature alarms Gb40		
High return temp: Setpoint: Differential:	30.0°C 1.0°C	High and low suction temperature values displaying / settings.
Low return temp: Setpoint: Differential:	5.0°C 1.0°C	
Unit regulation Temperature alarms Gb44		
High supply temp: Setpoint: Differential:	30.0°C 1.0°C	High and low discharge temperature values displaying / settings.
Low supply temp: Setpoint: Differential:	5.0°C 1.0°C	
Unit regulation Humidity alarms Gb46		
High return hum: Setpoint: Differential:	95.0% 5.0%	High and low suction pressure values displaying / settings.
Low return hum: Setpoint: Differential:	5.0% 5.0%	

Unit regulation Temperature and humidity alarm	Gb48	High and low humidity or temperature delay alarm displaying / settings.
Delay time:	600s	
Unit regulation overload fan	Gb49	Main fans thermal alarm delay displaying / settings.
Delay time:	10s	
Unit regulation Number alarm/hour	Gb50	High or low pressure alarm delay number (per hour) displaying / settings.
LP:	3	
HP/Overload Comp.:	1	
Unit regulation Number alarm/hour	Gb51	Heaters thermal alarm delay number (per hour) displaying / settings.
Overload Heater:	3	
Unit regulation	Gb56	Possibility to set integral time = 0 or not.
Disable Ti:	[√]	
Unit regulation	Gb57	Air flow regulation enabling.
En.Reg.Flow:	[√]	

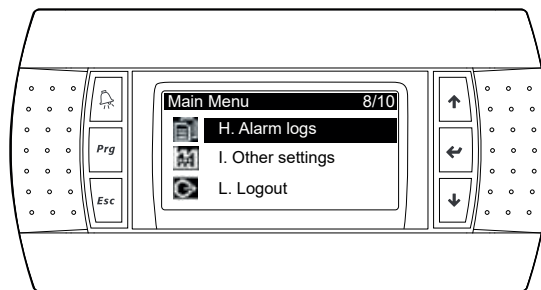

6.7.5 Menu Other settings

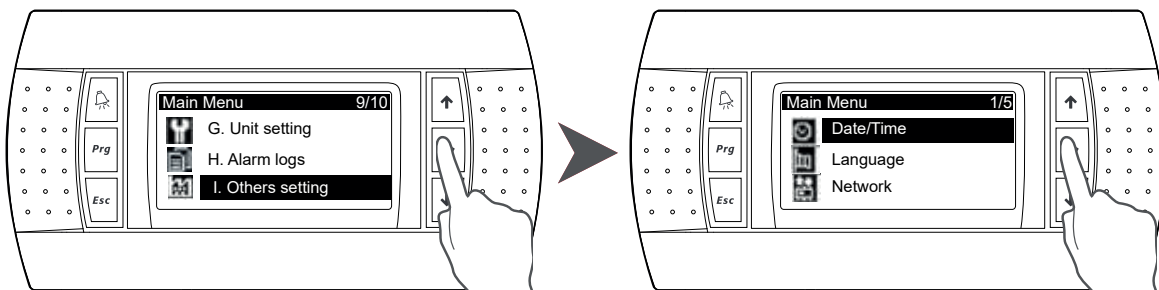

Data/Time

Date/Time change	IA01	Date and hour format settings.
Format:	DD/MM/YY	
Date:	05/04/19	
Hour:	10:52:02	
Day:	Friday	
Timezone	IA02	Time zone activation.
Current timezone:	GMT	
Change to:	GMT	
Update Timezone:	NO	

Emibyte DXi.A/DX.A Direct expansion close control

<p>SCHEDULER IA03</p> <p>Enable? Yes</p> <p>10:55 FRI 05/04/2019</p> <p>Sched. is not running Unit status: COMFORT</p>	Scheduler enablement.
<p>SCHEDULER IA04</p> <p>ECONOMY SETPOINT</p> <p>Supply : 20.0°C</p> <p>Return : 20.0°C</p> <p>Humidif. : 30.0%</p> <p>Dehumidif. : 70.0%</p> <p>Diff.press. : 300 Pa</p>	Economy type set point scheduler setting.
<p>SCHEDULER IA04a</p> <p>ECONOMY SETPOINT</p> <p>Source max speed: 90.0%</p>	Max speed setting of Economy type condenser scheduler.
<p>SCHEDULER IA05</p> <p>PRE-COMF SETPOINT</p> <p>Supply : 20.0°C</p> <p>Return : 23.0°C</p> <p>Humidif. : 30.0%</p> <p>Dehumidif. : 70.0%</p> <p>Diff.press. : 300 Pa</p>	Pre-comfort type set point scheduler setting.
<p>SCHEDULER IA05a</p> <p>PRE-COMF SETPOINT</p> <p>Source max speed: 90.0%</p>	Max speed setting of Pre-comfort type condenser scheduler.
<p>SCHEDULER IA06</p> <p>COMFORT SETPOINT</p> <p>Supply : 20.0°C</p> <p>Return : 23.0°C</p> <p>Humidif. : 30.0%</p> <p>Dehumidif. : 70.0%</p> <p>Diff.press. : 300 Pa</p>	Comfort type set point scheduler setting.
<p>SCHEDULER IA06a</p> <p>COMFORT SETPOINT</p> <p>Source max speed: 90.0%</p>	Max speed setting of Comfort type condenser scheduler.
<p>DAILY EVENTS IA07</p> <p>Day: Sunday</p> <p>Copy to: ALL Ok? No</p> <p>[] 1 --- ---</p> <p>[] 2 --- ---</p> <p>[] 3 --- ---</p> <p>[] 4 --- ---</p> <p>Save data? No</p>	Daily scheduler setting.
<p>VACATIONS PERIOD IA08</p> <p>Start End Status</p> <p>[] --/-- --/-- ---</p> <p>[] --/-- --/-- ---</p> <p>[] --/-- --/-- ---</p>	Vacation scheduler setting.
<p>SPECIAL DAYS IA09</p> <p>[] 1 --- ---</p> <p>[] 2 --- ---</p> <p>[] 3 --- ---</p> <p>[] 4 --- ---</p> <p>[] 5 --- ---</p> <p>[] 6 --- ---</p>	Daily scheduler setting.

Parameters output

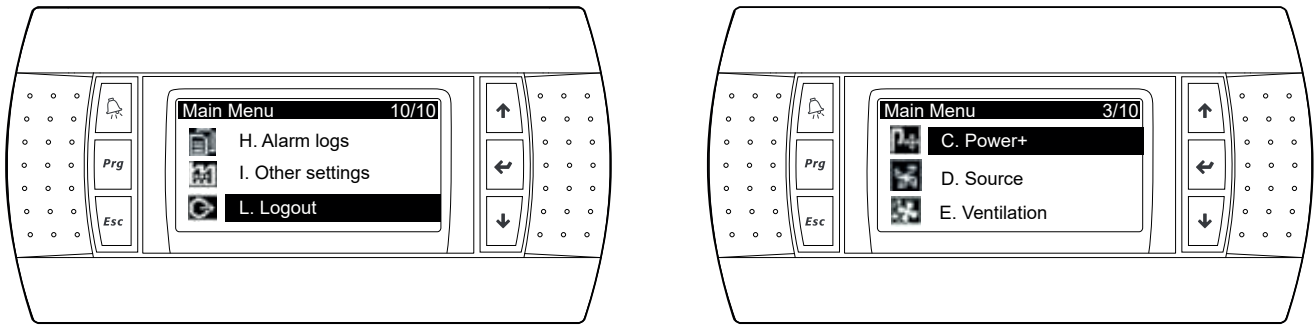

In order to access the menus again, it is necessary to re-enter the password.

Language

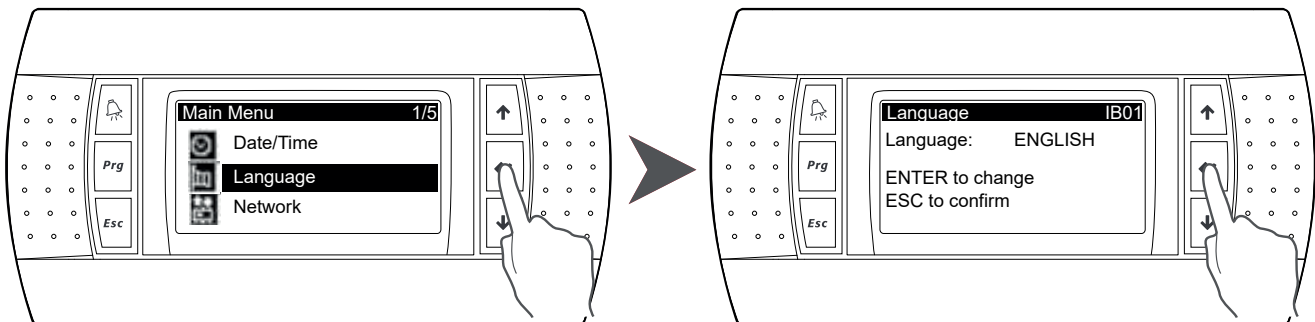

Press  key to select language desired and then press **Esc** to confirm.

Are available the following languages: Italian, English, German, Spanish and French.

Network

Is possible to manage till 16 units using multimaster network; the duty/stand-by rotation allows to exclude some units meanwhile the others are in backup mode, ready to start in case any alarm or issue occurs.

To maintain always operative the stand-by units a planned rotation is performed; the unit with more hours worked will switch OFF meanwhile the one with fewer hour worked switched ON.

Is possible to enable the regulation of all the network units on the master return probe.

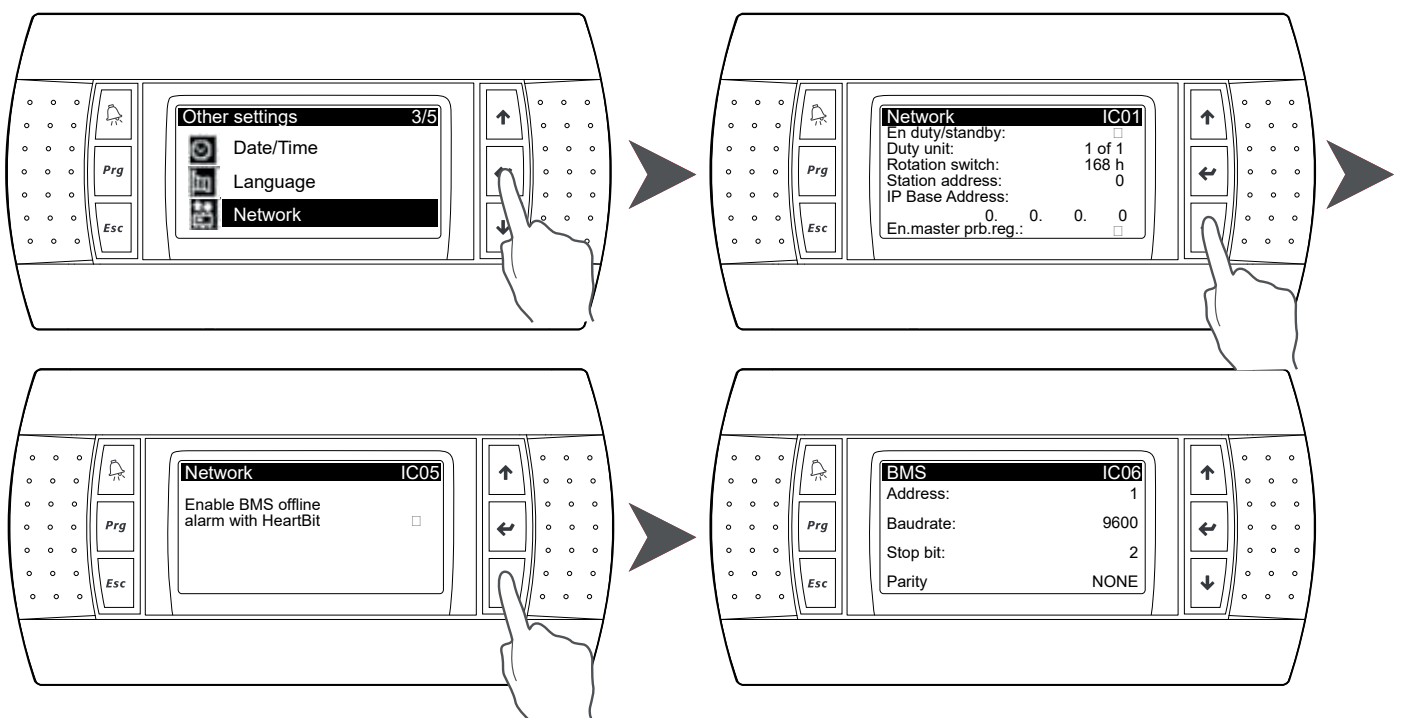

7. UNIT MAINTENANCE

7.1 General advices



Starting from 01/01/2016 the new European Regulation 517_2014, "Obligations concerning the containment, use, recovery and destruction of fluorinated greenhouse gases used in stationary refrigeration, air conditioning and heat pumps", became effective. This unit is subject to the following regulatory obligations, which have to be fulfilled by all operators:

- (a) Keeping the equipment records
- (b) Correct installation, maintenance and repair of equipment
- (c) Leakage control
- (d) Refrigerant recovery and disposal management
- (e) Presentation to the Ministry of the Environment of the annual declaration concerning the atmospheric emissions of fluorinated greenhouse gases.

Maintenance allows to:

- Keep the unit efficient;
- Prevent any failure;
- Extend the unit lifetime.



It is advisable to have a unit booklet with a purpose to sign any intervention performed helping the troubleshooting.



The maintenance operations must be performed in accordance with all the overmentioned prescriptions.



To perform any intervention pay attention to use any individual protection devices in accordance with local norms.



In case of winter stop, the water contained in the circuit can freeze harming the unit; is advisable to remove carefully all the water contained checking that all the circuit, all the internal/external siphons is empty.



Before to perform any electrical intervention is necessary to switch off the power supply turning the main switch to OFF position.

7.2 Unit access

Once the unit is installed, the access is allowed only to trained and expert technicians; the unit owner is the company legal representative, entity or natural person owner of the plants where it is installed. He is responsible to enforce all the safety norms indicated on the present Manual and the local norms

7.3 Scheduled maintenance

The unit owner has to be sure to make an adequate maintenance following the instructions on the present Manual, based on type, size, age of the unit and in accordance with the regulations and local norms.



If are installed leak sensors devices, these must be inspected once a year in order to ensure they work properly.

During his lifetime the unit must be subjected to inspections following the local norms in force; particularly, more strictly specifics don't exists, it is necessary refer to the following table (EN378-4, all.D) paying attention to the situations described.

SITUATION	Visual inspection (par. 4.2, p.ti a - l)	Circuit pressure test	Circuit leaks test
A	X	X	X
B	X	X	X
C	X		X
D	X		X

A	Inspection performed after an intervention, with possible effects on the mechanical resistance, after a change of purpose or after a stop longer than 2 years; all unit components must be replaced. Do not carry on any check with higher pressure than designed one.
B	Inspection performed after an intervention or a relevant system modification (also for it's components); this inspection can be restricted to the involved components, but if a refrigerant leak is detected the control must be performed to the all system
C	Inspection performed after changed a unit position; if there is the chance to have effects on the mechanical resistance refer to point A.
D	Leak test following a founded suspicion of refrigerant leak. The system must be inspected to detect the leak through either direct measures (use of leak detectors) or indirect measures (deduction of the leak presence following the analysis of the operating parameters), concentrating on the most subject parts (i.e. the joints).



If a fault is detected could endangers the reliable unit operation, it's necessary to rectified it before restart the unit.

7.3.1 Leaks test

If more restrictive norms not existing, on the unit a pressure test should be performed generally every 3 months, if during the test there is a leak suspect (for example after a capacity reduce or after a change in overheating / sub-cooling parameters), will be necessary to find the leak using suitable instruments, repair it and perform again the pressure test in accordance with national legislation in force.

Il risultato delle verifiche ed i provvedimenti adottati devono essere riportati sul Registro.

The staff busy in the leak test must not use free flames or ignition sources.

The refrigerant leaks must be find and repaired as soon as possible, any intervention must be performed by authorized personnel in conformity with the law and regulations in force.

7.3.2 Safety pressure switch check

If more restrictive norms not existing, the safety high pressure switches has to be inspected at least every 12 months, to verify the operation, the settings in case of manual restart switch and the correct installation.

7.3.3 Safety check

If more restrictive norms not existing, the external safety valves must be inspected at least every 6months to verify the operation. If a leak is detected the valve must be replaced.

Anyway every 5 years of using must be inspected in order to verify the set pressure s readable (on the valve), the installation and the characteristics in order to guarantee the system safety in accordance with the regulations in force.

7.3.4 Noise and vibration check

It is necessary to verify at least monthly the unit sound emissions and that the piping is not subject to abnormal vibrations can cause a breakage.

7.3.5 Sight glass check

The sight glass, installed on the refrigerant line immediately after the drier filter, allows to verify:

1) Basing on the sensible material color in the indicator is possible to understand if the humidity inside the circuit is acceptable; normally the indicator is light green if the humidity i slow, otherwise the color change into yellow (anyway follow the indication on the sight glass).

If the humidity is higher than expected should be necessary to replace the drier filter, or, in more serious cases all the refrigerant in the circuit.



After a long operation break the sight glass color check must be performed at least after 1 hour of nominal operation in order to allow the drier filter to extract some humidity from the refrigerant.

2) Using the sight glass is also possible to understand if the refrigerant charge is adequate; normally the charge is good if after 10' of nominal functioning there are not steam bubbles on the glass.

7.3.6 Refrigerant overheating check

To measure the refrigerant overheating on the evaporator outlet during the nominal unit operation must be measured:

- Evaporation pressure with a gauge connected to a suitable valve installed on the suction line;
- Suction temperature with a contact thermometer placed on the low pressure line, about 20cm from the evaporator.



If it is necessary to measure the temperature, move partially the isolation material from the suction line; the thermometer must be placed in a horizontal section using a suitable paste if necessary in order to improve the measure.

The refrigerant overheating is the difference between suction temperature, measured using the thermometer and the saturation one (dew value) corresponding to evaporation pressure, measured using the gauge.



All the units are of direct expansion with finned coil. The overheating values are factory settled into controller ($5 \div 7 \text{ }^\circ\text{C}$)

If the overheating value is lower than 5K or higher than 7K will be necessary act on the thermostatic valve parameters (refers to the cap. Dedicated) in order to stabilize the value around a $5 \div 7 \text{ K}$.

7.3.7 Refrigerant sub-cooling check

To measure the refrigerant sub-cooling to the condenser outlet during the nominal unit operation must be measured:

- Condensation pressure using a gauge connected to a suitable valve installed on the liquid line;
- The liquid refrigerant temperature, with a contact thermometer placed to the refrigerant line, on the unit.



The contact between the probe and the surface could be improved using a suitable paste.

The refrigerant sub-cooling is the difference between saturation temperature (bubble value) corresponding to condensation pressure, measured using a gauge, and the temperature of the liquid refrigerant, measured using a thermometer.

Se il valore del sotto-raffreddamento misurato risulta inferiore a 3 K o superiore a 10 K, potrebbe essere necessario modificare la quantità di refrigerante caricato nel circuito per fare in modo che esso si stabilizzi attorno a $5 \div 7 \text{ K}$.

7.3.8 Over currents protection devices check

The protection devices against the overcurrents must be controlled in order to verify their operating and integrity.



It is forbidden to by-pass the fuses on the unit or replace them with more powerful ones.



Fuses can reach very high temperatures and they can cause burns if not handled with the due precautions.



In case of adjustable devices (thermal relays or motor overload protections), the set absorption value must not be higher than the one on the Identification Tag of the component to be protected.

7.3.9 Contactors check

The contactors used to electrical charges drive must be checked to verify the integrity and the spool operating.

Moreover will be necessary verify the electrical cables are correctly fixed to the suitable terminals..

If is necessary the dirty and the dust must be removed because they could cause a noisy and inefficient unit operation.

7.4 Periodical checks



The commissioning operations must be performed following all the overmentioned indications.



All the operation mentioned in this part of the Manual **MUST BE PERFORMED BY QUALIFIED AND TRAINED TECHNICIANS**. Before any unit intervention be sure to disconnect it from the power supply. Pay attention when the operation involves the coil; the aluminium fins are particularly sharp and could cause serious injuries. After the maintenance operations be sure to close well all the panels using the apposite screwa.

7.4.1 Electrical system and control devices

Operations to perform	Timing						
	Daily	Monthly	Every 2 months	Every 6 months	Once year	Every 5 years	If needed
Unit operation and alarm presence check	X						
Unit visual inspection		X					
Unit noise and vibration check		X					
Safety devices and interlocks operation check				X			
Unit performances check				X			
Unit devices electrical absorptio check (fans, etc...)				X			
Unit power supply check				X			
Check every cable is correctly fixed in the correct terminal				X			
Check the insulation integrity of electrical cables					X		
Contactors operation and state check					X		
Controller and display operation check			X				
Check the controller settled parameters and values					X		
Clean all the electrical components from the dust (if present)				X			
Check the operation and the calibration of the probes and transducers					X		

7.4.2 Cooling circuit, coil and fans

Operations to perform	Timing						
	Daily	Monthly	Every 2 months	Every 6 months	Once year	Every 5 years	If needed
Visual inspection of the coil		X					
Cleaning operation of finned coil				X			
Cleaning operation of finned coil of outdoor unit (if present) ⁽¹⁾				X			
Air filter ⁽²⁾ cleaning operation / replacement			X				
Cleaning operation of the condensate tray			X				
Humidifier cylinder ⁽²⁾ cleaning operation			X				
Water flow check (F series)		X					
Fans noise and vibration check		X					
Fans power supply check				X			
Fans electrical connections check					X		
Check the operation and the calibration of the fans speed regulation system					X		
3way valve operation check (if BC option is present)					X		
Check the presence of air inside the hydraulic circuit (F series)		X					

7.4.3 Inverter/Compressors (DXi.A series)

Inverter and compressors visual inspection		X					
Compressors noise and vibration check			X				
Compressors and inverter power supply check				X			
Compressors and inverter electrical connections check					X		
Check the electrical cables of the compressors and inverter and that are regularly fixed to the terminals					X		



⁽¹⁾ If the unit is installed in strongly windy areas, near coasts or deserts or in areas subjects to wind and/or sand storms, or near airports, industries or in places with high levels of air pollution in general inspect the unit more frequently (**every three months or more**) to check the real condition of the surface protection.



⁽¹⁾ The filter and the humidifier cylinder clean situation depending by installation type

7.5 Straordinary maintenance

The unit's repairs must be performed by a qualified personnel informed about the system and equipped with individual protection devices in conformity with regulations and laws in force.

Besides if the interventions also concerning the welding or brazing in refrigerant present the technicians must wear also a mask with a protection filter specific against decomposition material could be created.



The cooling circuit contains refrigerant to an high pressure; It is necessary to discharge completely and with care the pressure before to perform any intervention on the cooling circuit.



If necessary, for the refrigerant transportation should follow the national regulations and laws in force.



It is forbidden to modify the unit or the components without a explicit authorization by the Manufacturer.

The intervention performed by technicians with different qualifications (such as welders, brazers, electricians, programmers, etc.) must be supervised by expert refrigeration technicians.

Welding and brazing operations must be performed by trained and expert technicians, following qualified procedures, only after the refrigerant is totally discharged from the circuit and the same is fluxed with azote.



During the welding and brazing operations all the heat sensitive devices must be removed or covered with wet clothes.



If the intervention requires a shut-off valve or interception valve must be removed, it is suggested to replace the seals with new ones.

If more restrictive norms not existing the intervention on the cooling circuit must be performed following the hereafter indication:

- a) Intervention risk valuation and analysis;
- b) Maintenance team training;
- c) Uninstallation and protection of devices to be repaired;
- d) Refrigerant recovery and vacuum execution;
- e) Cooling circuit fluxing and cleaning with anhydrous hydrogen;
- f) Intervention authorisation;
- g) Intervention execution;
- h) Repaired devices test (pressure test, leak test, functional test);
- i) Devices re-installation, vacuum execution and refrigerant charge;

8. DECOMMISSIONING

8.1 Disconnect the unit



All the disposal operations must be performed by expert technicians following the national legislation (destination county).

- Do not dissipate the refrigerant in the environment.
- Before the unit disconnection recovery (if present):
- All the refrigerant gas;
- All the antifreeze solutions contained in the hydraulic circuit;
- Lubricant oil from the compressors.

Waiting the disposal unit could be storage also to outdoor if all the circuits (electrical, cooling and hydraulic) closed and undamaged.

8.2 Disposal, recovery and recycling

If the frame and devices are unusable must be demolish and divide them for the recycling; particularly attention on the copper and aluminium.

All the materials must be recovered and disposed in accordance with the regulations and norms in force.



Recovery, reusing, recycle, regeneration and disposal of refrigerant must be performed by authorized personnel, expert and well equipped and informed, in accordance with the local regulations.



The refrigerant pressure in the cooling circuit can be high, discharge it with caution.



The refrigerant released in sudden way can cause freezing burns if it comes in contact with the skin.



The refrigerant filters used can contains a residual fluid parts which have to be eliminated before to proceed to disposal.



It is forbidden to release the refrigerant in teh environment.

8.2 RAEE Directive (UE members only)



The barred bin symbol, on the unit label, indicates the correspondence of the unit to electric and electronic device norm about the garbage.
The abandonment of the unit or the abusive disposal are punished by law.

All the unit this Manual refers complying with 2012/19/UE norm concerning the electric and electronic waste management (RAEE).
The unit must not be recycling with home waste because is composed by different material suitable to disposal only to recycling centers.
Ask to authorities where these centers are located in order to delivery all the different material a well recycling.
The system is potentially dangerous for human and animal health and the environment, also if any dangerous substance is contained (as 2011/65/UE (RoHS) Directive) is abandoned could create a serious pollution risk.
Read carefully the instructions before the first use of the system. Any use not clearly mentioned in the present Manual is forbidden, also for electrical shock risk for improper use.

9. DIAGNOSIS AND TROUBLESHOOTING

9.1 Fault finding

The controller manages all the troubles could verifying during the unit operation, segnaling the alarm situations and displaying the inconveniences type.

In the following table are listed the most common troubles could occur to the unit and for each the more probable causes and the possible solutions.

Before any intervention if an alarm occurs verify that:

- The operating conditions are the same of excepted, compatibles with the unit's operation limits;
- All the electrical cables and components are well fixed to their terminals;
- The set values for the involved parameters are coherent with the operative conditions.

Malfunction	Main Causes	Suggested actions
1. The unit doesn't work	a. The electrical panel is not powered	Check the voltage of each phase of the main supply line Check the main switch is closed (I position)
	b. The auxiliary circuit is not powered	Check the fuses of the auxiliary circuit (refer to the attached wiring diagram)
	c. The microprocessor doesn't start the unit	Check the electrical connections of the microprocessor Check the set values of the temperature
	d. The external impulse fails at the unit starting	Check the remote ON/OFF switch is closed (refer to the attached wiring diagram) Enable the external impulse from the user terminal (display) when the unit starts
2. Room temperature too high (high temperature alarm signal)	a. The unit doesn't work	Refer to point 1
	b. The control system setting is incorrect	Check the control system calibration
	c. The air flow is insufficient	Refer to point 6
	d. The compressor doesn't work	Refer to point 10
	e. The compressor capacity is insufficient	Refer to point 13
		Refer to point 14 Refer to point 15
	f. The reheating system doesn't work properly (if present)	Refer to point 7 and 16
	g. The control system doesn't work	Refer to the attached Controller Manual
h. Thermal load higher than estimated	Check the room thermal load	
3. Room temperature too low (low temperature alarm signal)	a. The control system setting is incorrect	Check the control system calibration
	b. The reheating system doesn't work properly (if present)	Refer to point 7 and 8
	c. The control system doesn't work	Refer to the attached Controller Manual
	d. Thermal load higher than estimated	Check the thermal loss value
4. Room humidity too high (high humidity alarm signal)	a. The control system calibration is incorrect	Check the control system calibration
	b. Latent load higher than estimated	Check the room latent load
	c. The compressor doesn't work when the unit is in dehumidification mode	Refer to point 10
	d. The control system doesn't work (if DH option is installed)	Refer to the attached Controller Manual

5. Room humidity too low (low humidity alarm signal)	a. Check the humidifier is present	Install the humidifier if is not present
	b. The humidity set-point is set at too low value	Increase the humidity set-point value
	c. The humidifier doesn't work	Refer to the attached Humidifier Manual
6. Low or no air flow capacity (air flow or fans alarm signal)	a. The fans are not powered	Check the fans electric circuit
	b. Clogged filter	Clean or replace the filters
	c. Obstruction presence in the air duct or pressure drop to high	Check the total pressure drop and compare it with the unit available pressure
	d. The fan thermal protection is active	Check the fans winding resistance (after reset, check the voltage and the electrical absorption)
7. The 3-way valve doesn't work (present in case of BC / BG option installed)	a. The control system doesn't work	Refer to the attached Controller Manual
	b. The valve servomotor doesn't work	Check the electrical connections and eventually replace the servomotor, if defective
	c. The valve is locked mechanically	Try to unlock manually the valve or replace it
8. High pressure switch is enabled	a. The system of condensation pressure control is doesn't work properly (if present)	Check the condensing control system is properly set and is working
	b. One or more condensing fans are not working	Check the intervention of thermal protection fan/s, if necessary replace the fan/s devector
	c. High pressure switch is not properly set	Replace the high pressure switch
	d. Discharge pressure too high	Refer to point 14
9. Low pressure switch is enabled	a. Low pressure switch is not properly set	Replace the low pressure switch
	b. Suction pressure too low	Refer to point 13
10. The compressor doesn't work	a. Automatic switch intervention	Riarmare l'interruttore automatico, verificare la pausa del cortocircuito
	b. Compressor internal protection intervention	Check the compressor winding resistance (after reset, check the voltage and electrical absorption) Check the operational parameters return to the nominal values
	c. The contactor doesn't work	Check the contacts and the contactor coil
11. The compressor is noisy	a. Liquid return to the compressor	Check the operating and the overheating of the expansion valve
	b. Compressor is damaged	Replace the compressor
12. Compressor high suction pressure	a. Thermal load higher than estimated	Check the room thermal load value

	b. Discharge pressure too high	Refer to point 14
	c. Return of liquid refrigerant to compressor's suction	Check that overheating of thermostatic valve is correct Check that the pressure transducer and the temperature probe of the thermostatic valve are well placed, fixed and insulated
13. Compressor suction low pressure (possible frost on the coil)	a. Ambient temperature too low	Refer to point 3
	b. Air flow too low or absent	Refer to point 6
	c. Clogged refrigerant filter	Check the refrigerant filter
	d. The electronic thermostatic valve parameters are not set correctly	Check the setting of the electronic valve parameters, in particular the integrity of the thermostatic device
	e. Insufficient refrigerant charge	Check a possible leak presence, if is detected repair it as soon as possible
	f. Discharge pressure too low	Refer to point 15
14. Compressors high discharge pressure	a. The control system of the condensation pressure is not working properly (if present)	Check the setting and functioning of the condensation control system
	b. Air too hot to the condenser	Check the presence of any condensation air re-cycle
	c. Condensation air flow insufficient	Check about any obstruction to the air flow in the finned exchanger coil
	d. Suction pressure too high	Refer to point 12
	e. Clogged fins of the condenser coil	Remove the clogging material
	f. Too much refrigerant in the circuit; condenser partially flooded	High refrigerant sub-cooling: remove part of refrigerant from the circuit
	g. Non condensable air or gas in the circuit	The flow sight glass presents gas bubbles; the compressor discharge temperature is too high, the cooling circuit must be discharged and re charged after the vacuum execution
15. Compressor discharge low pressure	a. The control system of the condensation pressure is not working properly	Check the setting and functioning of the condensation control system
	b. Suction pressure too low	Refer to point 13
16. Electrical heater doesn't work (if present)	a. Set-point temperature is too low	Increase the set-point temperature
	b. Magnetothermic switch disconnected	Check for any short-circuit; Reset the switch; Check the current absorption
	c. Safety thermostat enabled	Air flow too low, refer to point 5; Check the safety thermostat is working and, if necessary, replace it.
	d. The contactor doesn't work	Check the contact and contactors coil

17. La batteria calda non funziona (se presente optiona BC)	a. Hot water flow is insufficient	Check the hot water source Check the duct and make sure there is no leak or obstructions
	b. Hot water discharge temperature too low	Check the hot water distributor
	c. Set-point temperature too low	Increase the set-point temperature
18. Allarme di una sonda	a. The corresponding probe is defective or disconnected	Check the probe connection and its operation, if necessary replace it
19. Il ventilatore non parte	a. Current interruption / black out	Check the main switch and the power cable
	b. Protection switch open	Reset the protection switch and check the motor current and absorption
	c. Transformer protection activated	Check for any auxiliary short-circuit
	d. Contactor defective	Repair or replace the contactor
	e. The fans are not powered	Check the fans electric power supply
	f. The fan thermal protection block its operation	Check if the rotors are locked or if the power supply is insufficient or if there is a phase loss
	g. Controller not powered (display OFF)	Check for any auxiliary short-circuit
	h. Unit switched off (OFF position)	Turn ON on the keyboard



EMICON AC SPA

Via A. Volta, 49 ▪ cap 47014 ▪ Meldola (FC)
Tel. +39 0543 495611 ▪ Fax +39 0543 495612
emicon@emiconac.it ▪ www.emiconac.it

P.IVA e C.F 03402390409 ▪ R.E.A. 299199

Technical data shown on this booklet are not binding
The Company shall have the right to introduce at any time whatever modifications necessary to the improvement of the product.
The reference languages for the whole documentation are Italian and English. The other languages are to be considered only as guidelines.
