

# SERVICE MANUAL



Indoor unit	Outdoor unit
ARXG24KHTAP	AOYG24KBTB
ARXG30KHTAP	AOYG30KBTB
ARXG36KHTAP	AOYG36KBTB
ARXG45KHTAP	AOYG45KBTB
ARXG54KHTAP	AOYG54KBTB

## CONTENTS

SPECIFICATIONS.....	1
DIMENSIONS.....	8
REFRIGERANT SYSTEM DIAGRAM.....	21
INDOOR PCB CIRCUIT DIAGRAM.....	23
OUTDOOR PCB CIRCUIT DIAGRAM.....	25
ERROR DETECTION.....	28
PARTS (INDOOR UNIT).....	30
PARTS (OUTDOOR UNIT).....	40
ACCESSORIES.....	56

# Specifications ( Indoor unit )

Type				Duct		
				Inverter heat pump		
Model name				ARXG24KHTAP	ARXG30KHTAP	
Power supply				230 V ~ 50 Hz		
Power supply intake				Outdoor unit		
Available voltage range				198—264 V		
Capacity	Cooling	Rated	kW	6.8	8.5	
		Min.—Max.	Btu/h	23,200	29,000	
			kW	0.9—8.0	2.8—10.0	
	Heating	Min.—Max.	Btu/h	3,100—27,300	9,600—34,100	
			kW	7.5	10.0	
		Rated	Btu/h	25,600	34,100	
Input power	Cooling	Rated	kW	1.89	2.65	
		Max.		2.94	3.45	
	Heating	Rated	1.85	2.63		
		Max.	2.57	3.39		
	Fan	HIGH	W	70	150	
				MED	40	100
				LOW	25	75
				QUIET	15	65
	Current	Cooling	Rated	A	8.3	11.7
		Heating			8.1	11.7
	Power factor	Cooling		%	98.7	98.1
		Heating			98.7	97.7
EER	Cooling		kW/kW	3.60	3.21	
COP	Heating			4.06	3.80	
Moisture removal			L/h (pints/h)	1.8 (3.2)	2.3 (4.0)	
Maximum operating current *1		Cooling	A	13.6	22.6	
		Heating		13.6	22.6	
Fan	Airflow rate	Cooling	m <sup>3</sup> /h	HIGH	1,360	1,700
				MED	1,080	1,360
				LOW	880	1,190
				QUIET	680	1,070
		Heating		HIGH	1,360	1,700
				MED	1,080	1,360
				LOW	880	1,190
				QUIET	680	1,070
	Type × Q'ty		Sirocco fan × 2			
	Motor output		W	197	375	
Static pressure range			Pa	30 to 200		
Sound pressure level *2		Cooling	dB (A)	HIGH	32	36
				MED	28	33
				LOW	24	30
				QUIET	21	29
		Heating		HIGH	32	36
				MED	28	33
				LOW	24	30
				QUIET	21	29
Sound power level		Cooling	dB (A)	57	63	
		Heating		57	65	
Heat exchanger type		Dimensions (H × W × D)		420 × 758 × 39.9		
		Fin pitch		1.4		
		Rows × Stages		3 × 20		
		Pipe type		Copper		
		Fin type		Aluminum		
Enclosure		Material		Steel sheet		
		Color		—		
Dimensions (H × W × D)	Net		mm	300 × 1,000 × 700		
	Gross			400 × 1,238 × 875		
Weight	Net		kg	36		
	Gross			43	44	
Connection pipe	Size	Liquid	mm (in)	Ø 6.35 (1/4)	Ø 9.52 (3/8)	
		Gas		Ø 12.70 (1/2)	Ø 15.88 (5/8)	
Drain hose	Method		Flare			
	Material		PVC			
Operation range	Size	mm		Ø 25 (I.D.), Ø 32 (O.D.)		
		°C		18 to 32		
Remote control (Option)	Cooling		°C	18 to 32		
	Heating			80 or less		
				16 to 30		
Remote control (Option)				Wired remote controller, Wireless remote controller, Mobile app*3 (FGLair™)		
<b>NOTES:</b>						
<ul style="list-style-type: none"> <li>Specifications are based on the following conditions: <ul style="list-style-type: none"> <li>Cooling: Indoor temperature of 27 °CDB/19 °CWB, and outdoor temperature of 35 °CDB/24 °CWB.</li> <li>Heating: Indoor temperature of 20 °CDB/15 °CWB, and outdoor temperature of 7 °CDB/6 °CWB.</li> <li>Pipe length: 5 m, Height difference: 0 m. (Between outdoor unit and indoor unit.)</li> <li>Standard static pressure; 24 type: 35 Pa, 30 type: 47 Pa</li> </ul> </li> <li>Protective function might work when using it outside the operation range.</li> <li>*1: Maximum operating current is the total current of the indoor unit and the outdoor unit.</li> <li>*2: Sound pressure level: <ul style="list-style-type: none"> <li>Measured values in manufacturer's anechoic chamber.</li> <li>Because of the surrounding sound environment, the sound levels measured in actual installation conditions might be higher than the specified values here.</li> </ul> </li> <li>*3: Available on Google Play™ store or on App Store®. Optional WLAN adapter is also required. For details, refer to the setting manual.</li> </ul>						

Model name		ARXG24KHTAP	ARXG30KHTAP
Energy efficiency class	Cooling	A <sup>++</sup>	A <sup>++</sup>
	Heating (Average)	A <sup>+</sup>	A <sup>+</sup>
Pdesign	Cooling	6.8 (35°C)	8.5 (35°C)
	Heating (Average)	6.0 (-10°C)	8.0 (-10°C)
SEER	Cooling	6.50	6.23
SCOP	Heating (Average)	4.10	4.00
Annual energy consumption	QCE	366	477
	QHE (Average)	2,048	2,796

Type				Duct		
				Inverter heat pump		
Model name				ARXG36KHTAP	ARXG45KHTAP	ARXG54KHTAP
Power supply				230 V ~ 50 Hz		
Power supply intake				Outdoor unit		
Available voltage range				198—264 V		
Capacity	Cooling	Rated	kW	9.5	12.1	13.4
			Btu/h	32,400	41,300	45,700
		Min.—Max.	kW	2.8—11.2	4.0—14.0	4.5—14.5
	Heating		Btu/h	9,600—38,200	13,600—47,800	15,400—49,500
		Rated	kW	10.8	13.5	15.5
			Btu/h	36,900	46,100	52,900
	Min.—Max.	kW	2.7—12.7	4.2—16.2	4.7—16.5	
		Btu/h	9,200—43,300	14,300—55,300	16,000—56,300	
Input power	Cooling	Rated	kW	2.86	3.53	4.42
		Max.		3.85	4.64	4.81
	Heating	Rated	2.48	3.37	3.89	
		Max.	3.72	4.34	4.63	
	Fan	HIGH	W	150	225	225
		MED		90	135	135
		LOW		60	90	90
		QUIET		45	70	70
Current	Cooling	Rated	A	12.6	15.5	19.4
	Heating			11.0	14.8	17.1
Power factor	Cooling		%	98.4	98.8	99.0
	Heating			98.1	98.9	99.0
EER	Cooling		kW/kW	3.32	3.43	3.03
COP	Heating		kW/kW	4.35	4.01	3.98
Moisture removal			L/h (pints/h)	2.0 (3.5)	2.6 (4.6)	3.7 (6.5)
Maximum operating current *1		Cooling	A	22.6	28.5	
		Heating		22.6	28.5	
Fan	Airflow rate	Cooling	m <sup>3</sup> /h	HIGH	2,050	2,550
				MED	1,640	2,040
				LOW	1,330	1,650
				QUIET	1,070	1,430
		Heating		HIGH	1,850	2,550
				MED	1,640	2,040
				LOW	1,330	1,650
				QUIET	1,070	1,430
	Type × Q'ty		Sirocco fan × 3			
	Motor output		W		375	
Static pressure range			Pa	30 to 200		
Sound pressure level *2	Cooling	HIGH	dB (A)	36	39	
		MED		31	35	
		LOW		28	31	
		QUIET		26	29	
	Heating	HIGH		33	39	
		MED		31	35	
		LOW		28	31	
		QUIET		26	29	
Sound power level	Cooling	dB (A)	64	67		
	Heating		63	69		
Heat exchanger type	Dimensions (H × W × D)		mm	420 × 1,158 × 39.9		
	Fin pitch			1.4		
	Rows × Stages			3 × 20		
	Pipe type			Copper		
	Fin type			Aluminum		
Enclosure	Material		Steel sheet			
	Color		—			
Dimensions (H × W × D)	Net		mm	300 × 1,400 × 700		
	Gross			400 × 1,638 × 875		
Weight	Net		kg	46		
	Gross			56		
Connection pipe	Size	Liquid	mm (in)	Ø 9.52 (3/8)		
		Gas		Ø 15.88 (5/8)		
Drain hose	Method		Flare			
	Material		PVC			
Operation range	Size	mm	Ø 25 (I.D.), Ø 32 (O.D.)			
			Cooling	°C	18 to 32	
	Heating	°C	80 or less			
			16 to 30			
Remote control (Option)				Wired remote controller, Wireless remote controller, Mobile app*3 (FGLair™)		

**NOTES:**

- Specifications are based on the following conditions:
  - Cooling: Indoor temperature of 27 °CDB/19 °CWB, and outdoor temperature of 35 °CDB/24 °CWB.
  - Heating: Indoor temperature of 20 °CDB/15 °CWB, and outdoor temperature of 7 °CDB/6 °CWB.
  - Pipe length: 5 m, Height difference: 0 m. (Between outdoor unit and indoor unit.)
  - Standard static pressure; 36 type: 47 Pa, 45 and 54 types: 60 Pa
- Protective function might work when using it outside the operation range.
- \*1: Maximum operating current is the total current of the indoor unit and the outdoor unit.
- \*2: Sound pressure level:
  - Measured values in manufacturer's anechoic chamber.
  - Because of the surrounding sound environment, the sound levels measured in actual installation conditions might be higher than the specified values here.
- \*3: Available on Google Play™ store or on App Store®. Optional WLAN adapter is also required. For details, refer to the setting manual.

Model name		ARXG36KHTAP	
Energy efficiency class	Cooling		A <sup>++</sup>
	Heating (Average)		A <sup>+</sup>
Pdesign	Cooling	kW	9.5 (35°C)
	Heating (Average)		8.7 (-10°C)
SEER	Cooling	kWh/kWh	6.10
SCOP	Heating (Average)		4.20
Annual energy consumption	QCE	kWh/a	544
	QHE (Average)		2,898

# Specifications ( Outdoor unit )

Type			Inverter heat pump
Model name			AOYG24KBTB
Power supply			230 V ~ 50 Hz
Power supply intake			Outdoor unit
Available voltage range			198—264 V
Starting current			8.3
Fan	Airflow rate	Cooling	2,700
		Heating	2,700
	Type × Q'ty		Propeller × 1
	Motor output		49
Sound pressure level *1	Cooling	dB (A)	53
	Heating		54
Sound power level	Cooling	dB (A)	65
	Heating		66
Heat exchanger type	Dimensions (H × W × D)		Main1: 672 × 881 × 18.2 Main2: 672 × 851 × 18.2
	Fin pitch		1.3
	Rows × Stages		2 × 32
	Pipe type		Copper tube
	Fin	Type (Material)	Aluminum
		Surface treatment	PC fin
Compressor	Type × Q'ty		DC Twin rotary × 1
	Motor output		1,060
Refrigerant	Type (Global warming potential)		R32 (675)
	Factory charge		g
Refrigerant oil	Type		RmM68AF
	Amount		cm <sup>3</sup>
			400
Enclosure	Material		Steel sheet
	Color		Beige Approximate color of Munsell 10YR 7.5/1.0
Dimensions (H × W × D)	Net		716 × 820 × 315
	Gross		776 × 961 × 450
Weight	Net		42
	Gross		46
Connection pipe	Size	Liquid	Ø6.35 (1/4)
		Gas	Ø12.70 (1/2)
	Method		Flare
	Pre-charge length		20
	Max. length		30
	Max. height difference		25
Operation range	Cooling	°C	-15 to 46
	Heating		-15 to 24
Drain hose	Material		PP
	Size		mm
			Ø13.0 (I. D.), Ø16.0 to Ø16.8 (O. D.)

## NOTES:

- Specifications are based on the following conditions:
  - Cooling: Indoor temperature of 27 °CDB/19 °CWB, and outdoor temperature of 35 °CDB/24 °CWB.
  - Heating: Indoor temperature of 20 °CDB/15 °CWB, and outdoor temperature of 7 °CDB/6 °CWB.
  - Pipe length: 5 m, Height difference: 0 m. (Between outdoor unit and indoor unit.)
- Protective function might work when using it outside the operation range.
- \*1: Sound pressure level
  - Measured values in manufacturer's anechoic chamber.
  - Because of the surrounding sound environment, the sound levels measured in actual installation conditions might be higher than the specified values here.

Type				Inverter heat pump	
Model name				AOYG30KBTB	AOYG36KBTB
Power supply				230 V ~ 50 Hz	
Power supply intake				Outdoor unit	
Available voltage range				198–264 V	
Starting current				11.7	12.6
Fan	Airflow rate	Cooling	m <sup>3</sup> /h	3,750	
		Heating		3,750	
	Type × Q'ty			Propeller × 1	
	Motor output			100	
Sound pressure level *1		Cooling	dB (A)	53	55
		Heating		55	55
Sound power level		Cooling	dB (A)	68	70
		Heating		69	70
Heat exchanger type	Dimensions (H × W × D)		mm	Main1: 756 × 905 × 18.2 Main2: 756 × 905 × 18.2	
	Fin pitch			1.45	
	Rows × Stages			1 × 36	
	Pipe type			Copper	
	Fin	Type (Material)		Aluminum	
		Surface treatment		Blue fin	
Compressor	Type × Q'ty		DC Twin rotary × 1		
	Motor output		1,500		
Refrigerant	Type (Global warming potential)		R32 (675)		
	Factory charge	g	1,900		
Refrigerant oil	Type		FW68D		
	Amount	cm <sup>3</sup>	600		
Enclosure	Material			Steel sheet	
	Color			Beige Approximate color of Munsell 10YR 7.5/1.0	
Dimensions (H × W × D)	Net		mm	788 × 940 × 320	
	Gross			966 × 1,027 × 445	
Weight	Net		kg	52	
	Gross			60	
Connection pipe	Size	Liquid	mm (in)	Ø9.52 (3/8)	
		Gas		Ø15.88 (5/8)	
	Method			Flare	
	Pre-charge length			30	
	Max. length			50	
	Max. height difference			30	
Operation range		Cooling	°C	-15 to 46	
		Heating		-15 to 24	
Drain hose	Material			LDPE	
	Size			Ø13.0 (I. D.), Ø16.0 to Ø16.8 (O. D.)	

**NOTES:**

- Specifications are based on the following conditions:
  - Cooling: Indoor temperature of 27 °CDB/19 °CWB, and outdoor temperature of 35 °CDB/24 °CWB.
  - Heating: Indoor temperature of 20 °CDB/15 °CWB, and outdoor temperature of 7 °CDB/6 °CWB.
  - Pipe length: 5 m, Height difference: 0 m. (Between outdoor unit and indoor unit.)
- Protective function might work when using it outside the operation range.
- \*1: Sound pressure level
  - Measured values in manufacturer's anechoic chamber.
  - Because of the surrounding sound environment, the sound levels measured in actual installation conditions might be higher than the specified values here.

Type				Inverter heat pump			
Model name				AOYG45KBTB	AOYG54KBTB		
Power supply				230 V ~ 50 Hz			
Power supply intake				Outdoor unit			
Available voltage range				198–264 V			
Starting current				A			
				15.5	20.9		
Fan	Airflow rate	Cooling	m <sup>3</sup> /h	4,450	4,450		
		Heating		4,450	4,450		
	Type × Q'ty		Propeller × 1				
	Motor output		W	120			
Sound pressure level *1		Cooling	dB (A)	57	57		
		Heating		57	59		
Sound power level		Cooling	dB (A)	71	73		
		Heating		71	73		
Heat exchanger type		Dimensions (H × W × D)	mm	Main1: 966 × 905 × 18.2 Main2: 966 × 905 × 18.2 Sub: 966 × 543 × 18.2			
		Fin pitch		1.45			
		Rows × Stages		1 × 46			
		Pipe type		Copper			
		Fin	Type (Material)		Aluminum		
			Surface treatment		Blue fin		
Compressor		Type × Q'ty	DC Twin rotary × 1				
		Motor output	W				
				2,180			
Refrigerant		Type (Global warming potential)		R32 (675)			
		Factory charge		g			
				2,700			
Refrigerant oil		Type		RmM68AF			
		Amount		cm <sup>3</sup>			
				800			
Enclosure		Material		Steel sheet			
		Color		Beige Approximate color of Munsell 10YR 7.5/1.0			
Dimensions (H × W × D)		Net		mm			
		Gross		998 × 940 × 320			
				1,176 × 1,027 × 445			
Weight		Net		kg			
		Gross		67			
				75			
Connection pipe		Size	Liquid	mm (in)	Ø9.52 (3/8)		
			Gas		Ø15.88 (5/8)		
		Method		Flare			
		Pre-charge length		30			
		Max. length		m			
		Max. height difference		50			
				30			
Operation range		Cooling	°C	-15 to 46			
		Heating		-15 to 24			
Drain hose		Material		LDPE			
		Size		mm			
				Ø13.0 (I. D.), Ø16.0 to Ø16.8 (O. D.)			

**NOTES:**

- Specifications are based on the following conditions:
  - Cooling: Indoor temperature of 27 °CDB/19 °CWB, and outdoor temperature of 35 °CDB/24 °CWB.
  - Heating: Indoor temperature of 20 °CDB/15 °CWB, and outdoor temperature of 7 °CDB/6 °CWB.
  - Pipe length: 5 m, Height difference: 0 m. (Between outdoor unit and indoor unit.)
- Protective function might work when using it outside the operation range.
- \*1: Sound pressure level
  - Measured values in manufacturer's anechoic chamber.
  - Because of the surrounding sound environment, the sound levels measured in actual installation conditions might be higher than the specified values here.



# Dimensions ( Indoor unit )

## Models: ARXG24KHTAP and ARXG30KHTAP

Unit: mm

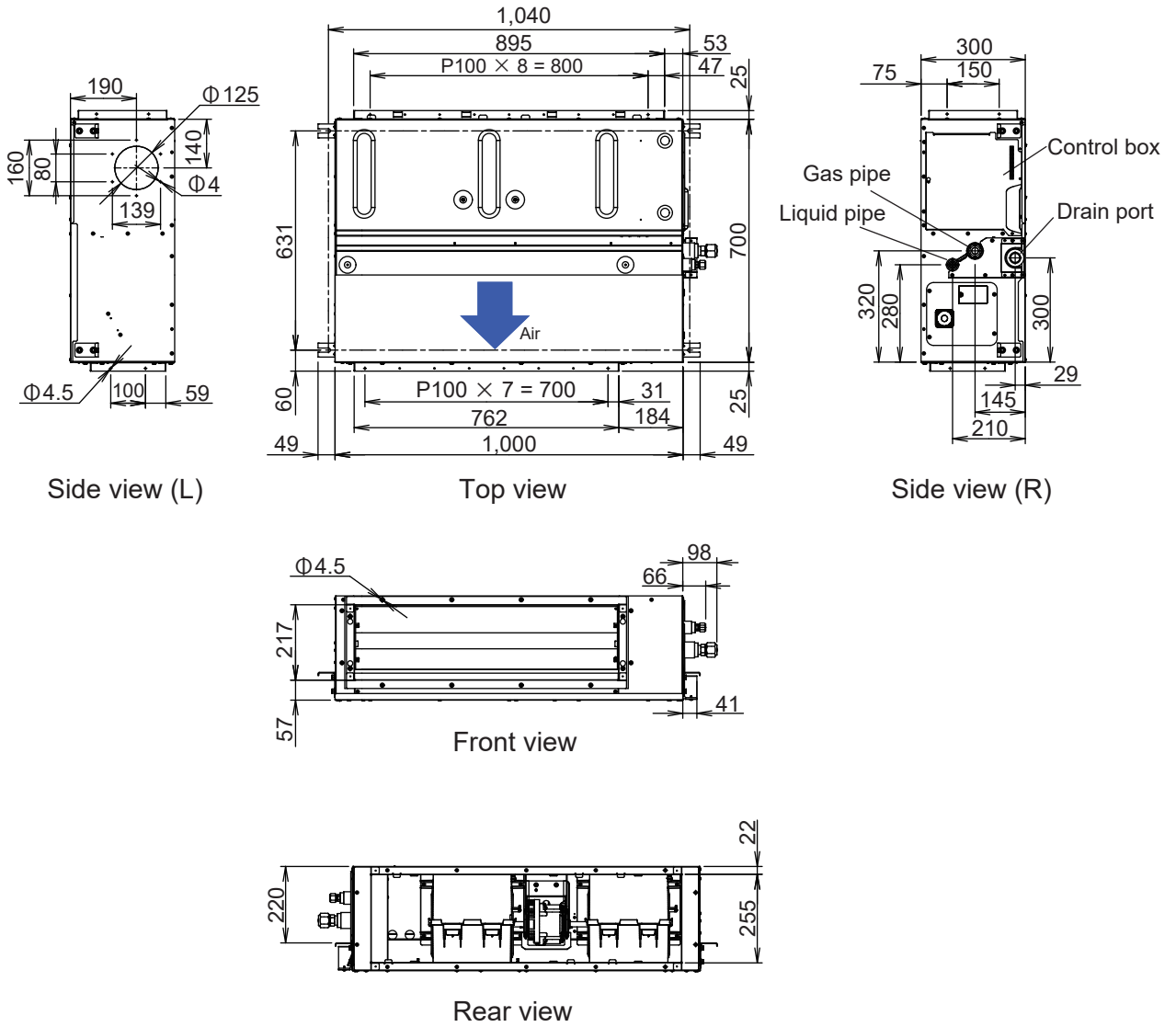

# Models: ARXG36KHTAP, ARXG45KHTAP, and ARXG54KHTAP

Unit: mm

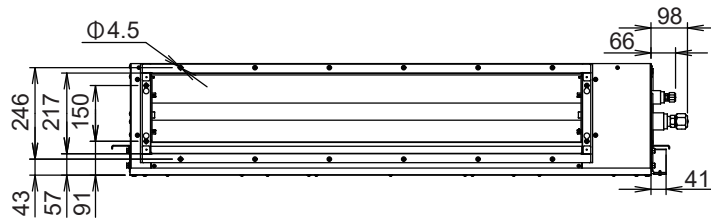
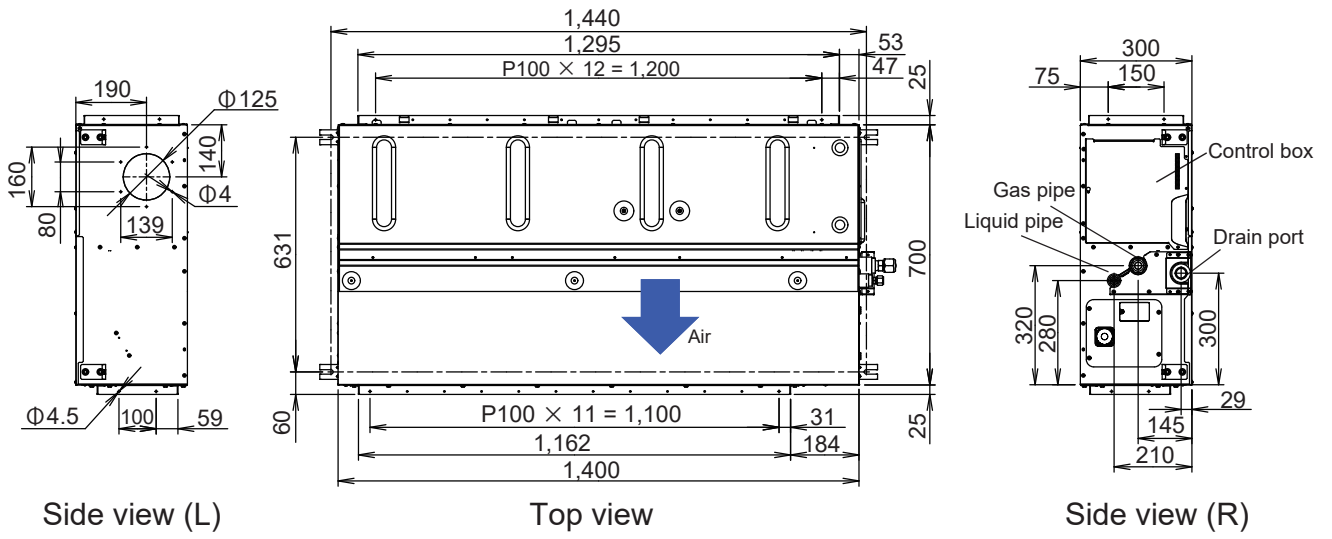

Front view

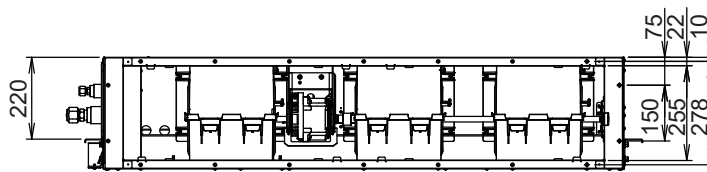

Rear view

# Installation space requirement

Provide sufficient installation space for product safety.

**Models: ARXG24KHTAP, ARXG30KHTAP, ARXG36KHTAP, ARXG45KHTAP, and ARXG54KHTAP**

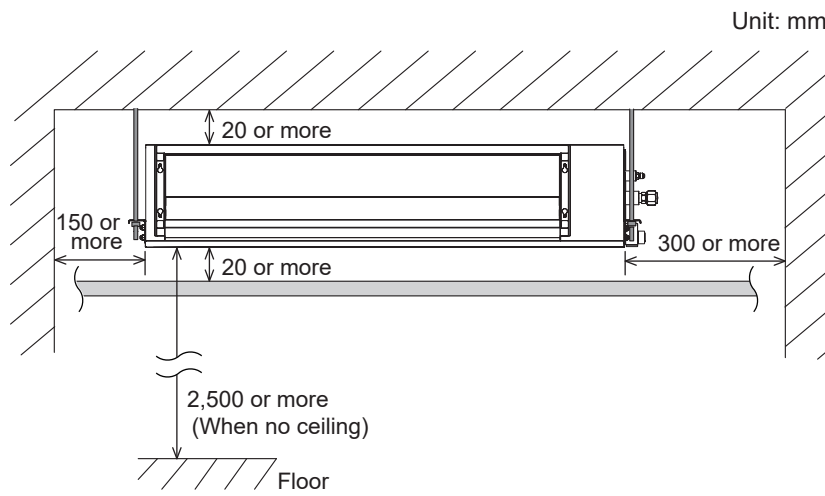

# Maintenance space requirement

For future maintenance and service access, provide sufficient maintenance space.

**NOTE:** Do not place any wiring or illumination in the maintenance space, as they will impede service.

## Models: ARXG24KHTAP, ARXG30KHTAP, ARXG36KHTAP, ARXG45KHTAP, and ARXG54KHTAP

- Provide a service access for maintenance purposes.

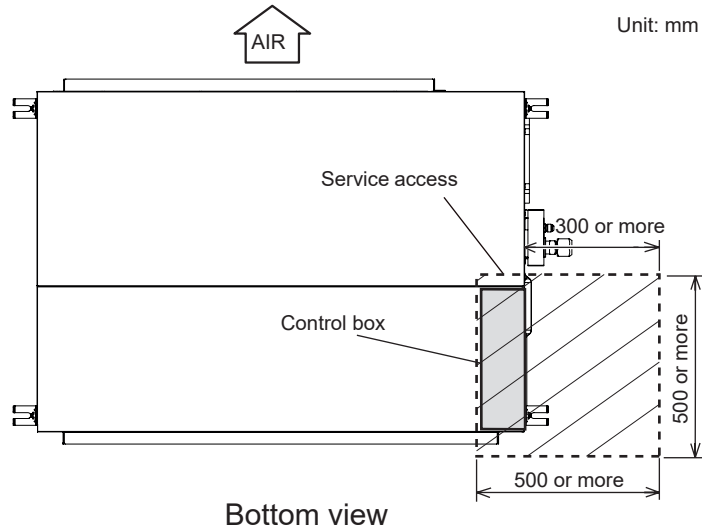

- The service access necessary for fan units and filter maintenance.

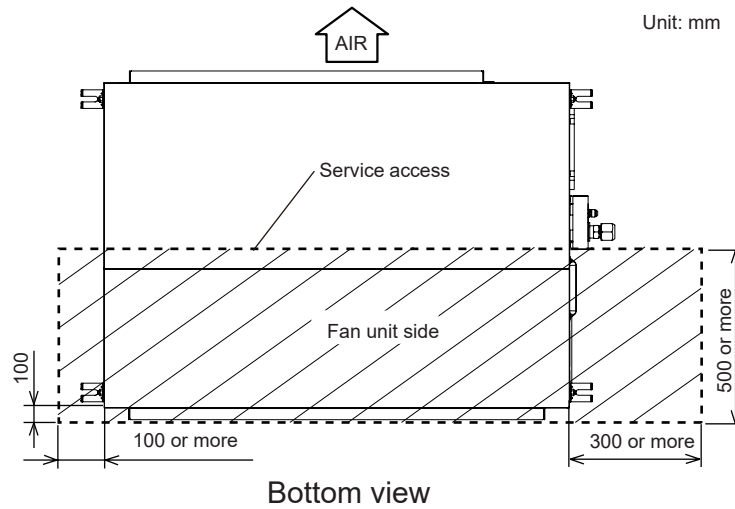

# Dimensions ( Outdoor unit )

## Model: AOYG24KBTB

Unit: mm

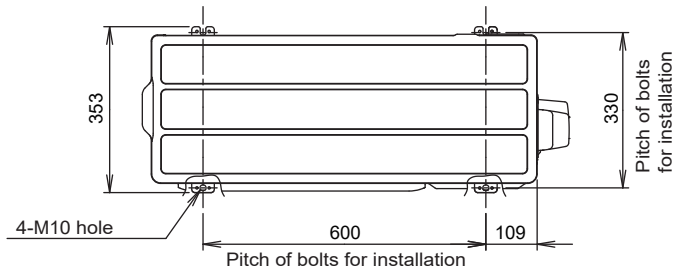

Top view

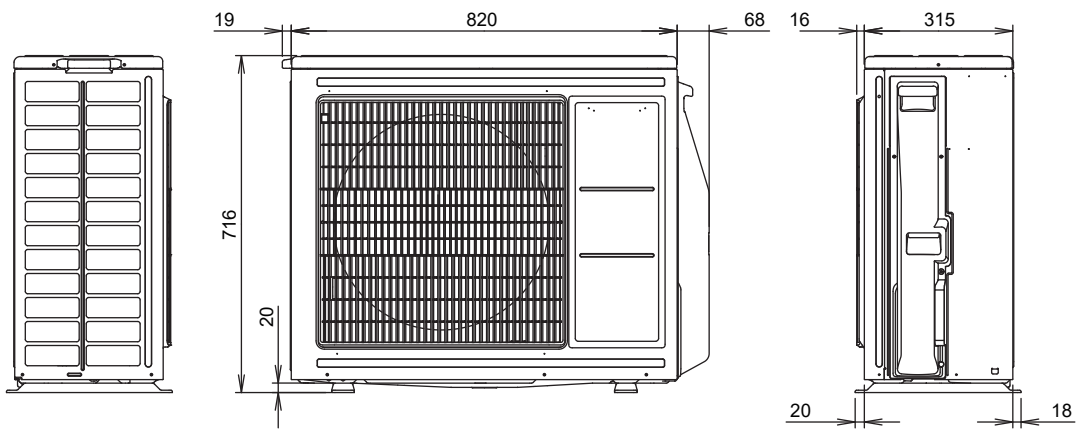

Side view

Front view

Side view

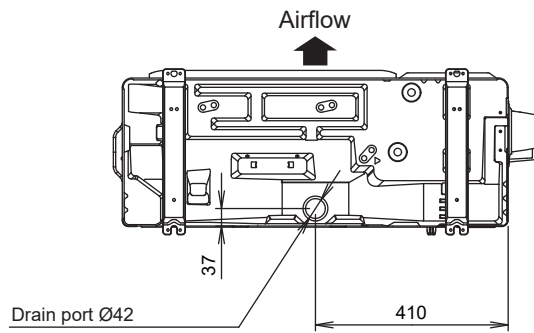

Bottom view

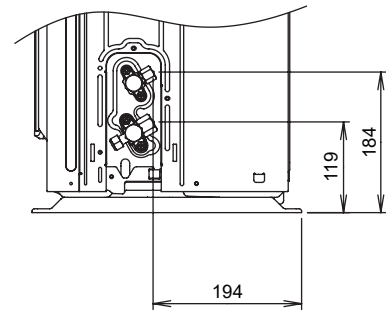

Side view (Valve part)

# Models: AOYG30KBTB and AOYG36KBTB

Unit: mm

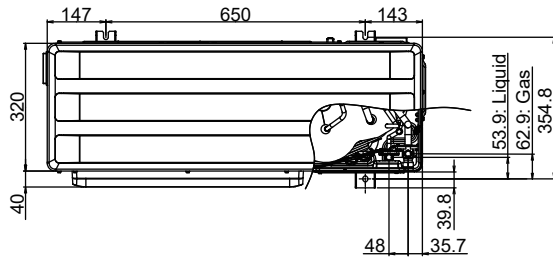

Top view

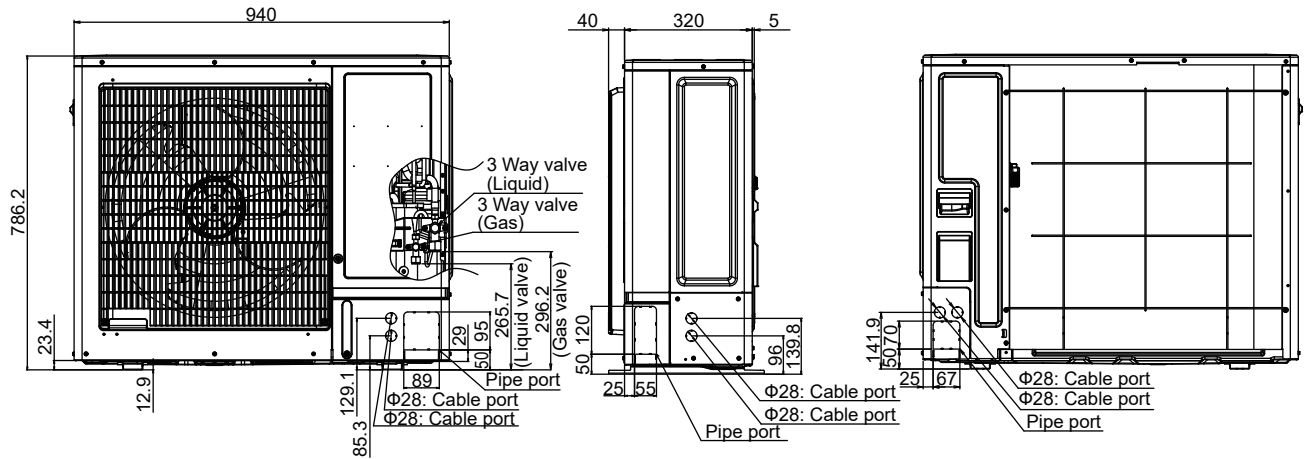

Front view

Side view

Rear view

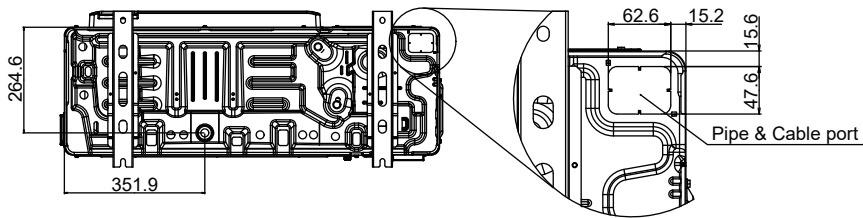

Bottom view

# Models: AOYG45KBTB and AOYG54KBTB

Unit: mm

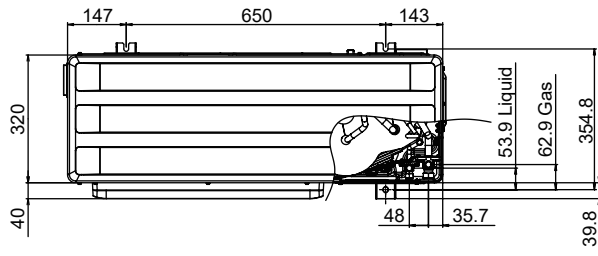

Top view

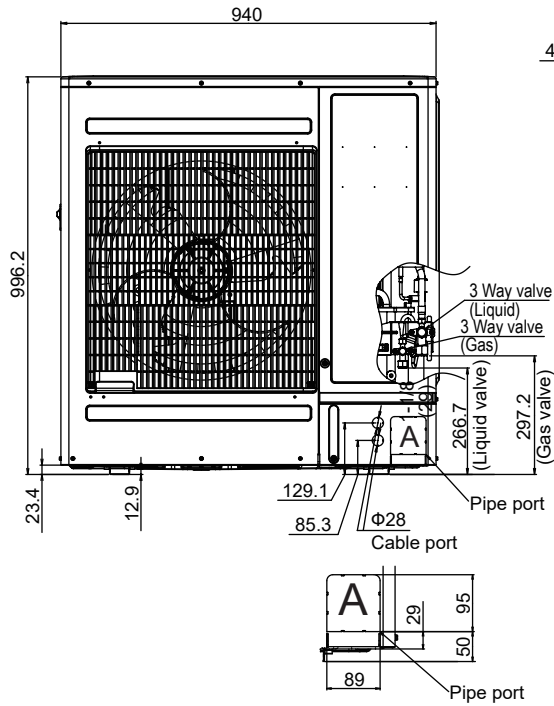

Front view

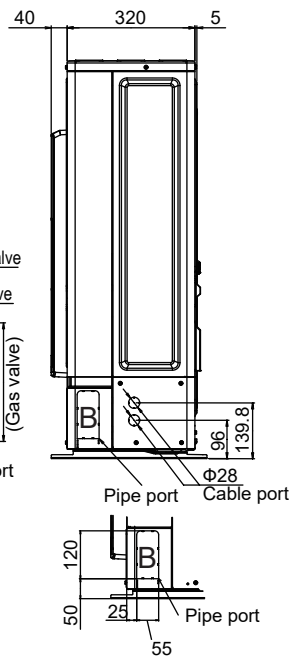

Side view

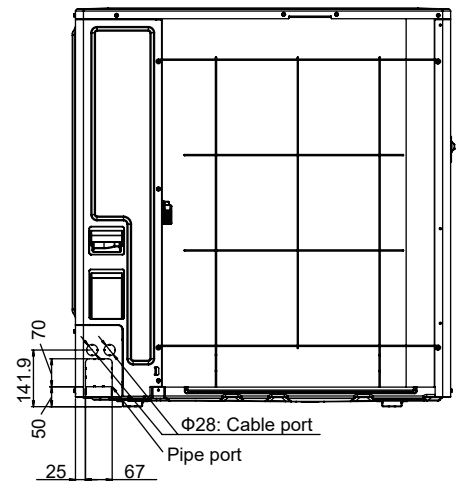

Rear view

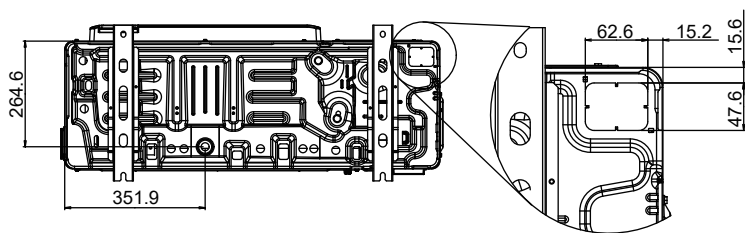

Bottom view

Pipe & Cable port

# Installation space

## Model: AOYG24KBTB

### Space requirement

Provide sufficient installation space for product safety.

#### ⚠ CAUTION

Keep the space shown in the installation examples.

If the installation is not performed accordingly, it could cause a short circuit and result in a lack of operating performance.

### Single outdoor unit installation

- When the upper space is open:

Unit: mm

Obstacles at rear only

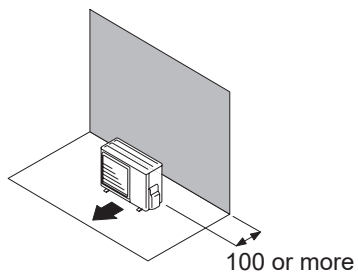

Obstacles at rear and sides

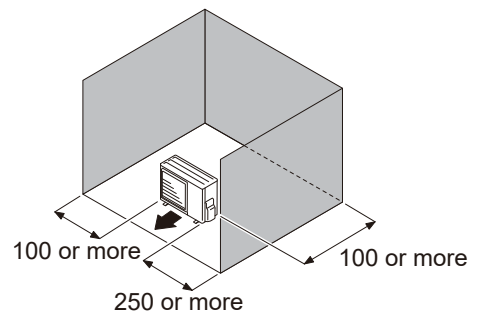

Obstacles at front

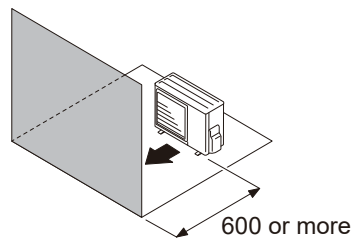

Obstacles at front and rear

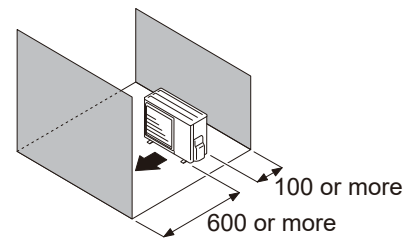

- When there is an obstruction in the upper space:

Unit: mm

Obstacles at rear and above

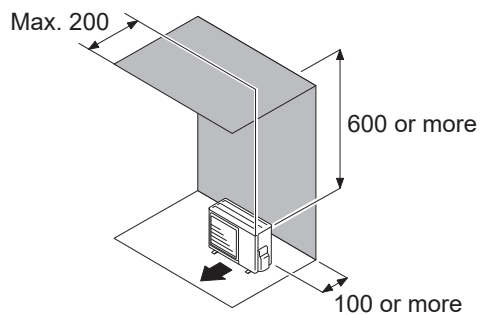

Obstacles at rear, sides, and above

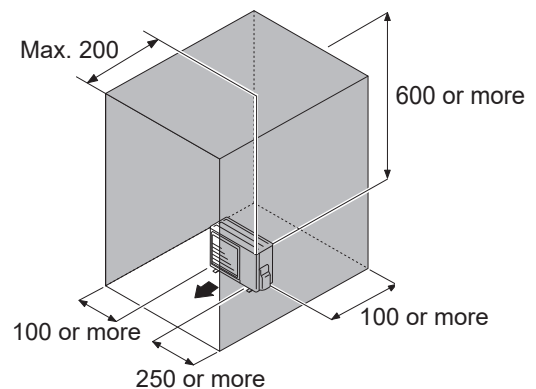



## Multiple outdoor unit installation

- Provide at least 250 mm of space between the outdoor units if multiple units are installed.
- When routing the piping from the side of an outdoor unit, provide space for piping.
- No more than 3 units must be installed side by side.  
When 3 units or more are arranged in a line, provide the space as shown in the following example **“When an obstruction in the upper space:”**.

- **When the upper space is open:**

Unit: mm

Obstacles at rear only

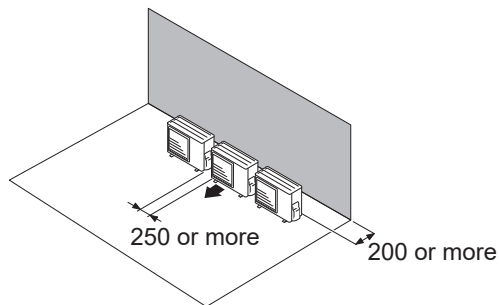

Obstacles at front only

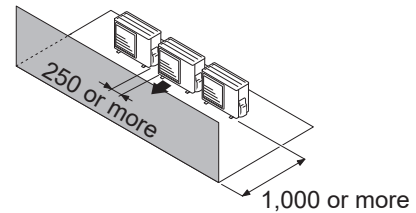

Obstacles at front and rear

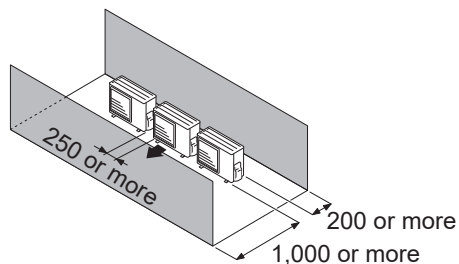

- **When an obstruction in the upper space:**

Unit: mm

Obstacles at rear and above.

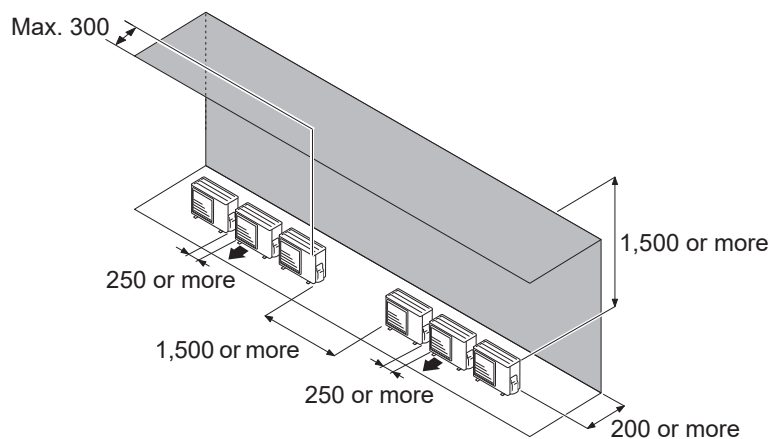

# Outdoor units installation in multi-row

Unit: mm

Single parallel unit arrangement

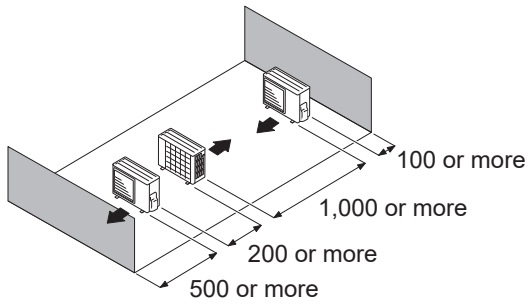

Multiple parallel unit arrangement

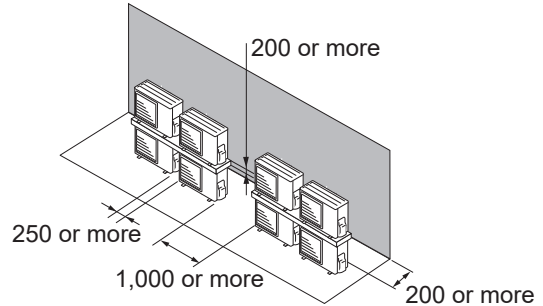
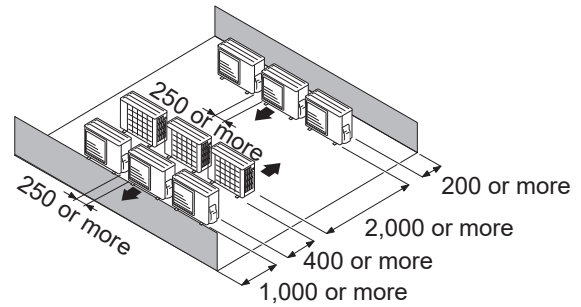

## NOTES:

- If the space is larger than stated above, the condition will be the same as when there is no obstacle.
- When installing the outdoor unit, be sure to open the front and left side to obtain better operation efficiency.

## ⚠ CAUTION

- Do not install the outdoor unit in two-stage where the drain water could freeze. Otherwise the drainage from the upper unit may form ice and cause a malfunction of the lower unit.
- When the outdoor temperature is 0 °C or less, do not use the accessory drain pipe and drain cap. If the drain pipe and drain cap are used, the drain water in the pipe may freeze in extremely cold climate. (For reverse cycle model only.)
- In area with heavy snowfall, if the inlet and outlet of the outdoor unit is blocked with snow, it might become difficult to get warm, and it is likely to cause product malfunction. Construct a canopy and a pedestal, or place the unit on a high stand that is locally installed.

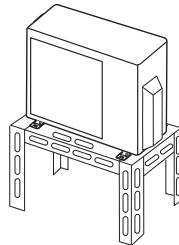

# Models: AOYG30KBTB, AOYG36KBTB, AOYG45KBTB, and AOYG54KBTB

## Space requirement

Provide sufficient installation space for product safety.

### Single outdoor unit installation

- When the upper space is open:

Unit: mm

When there are obstacles at the rear only.

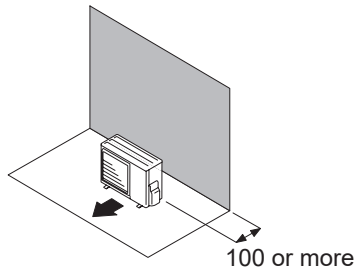

When there are obstacles at the rear and sides.

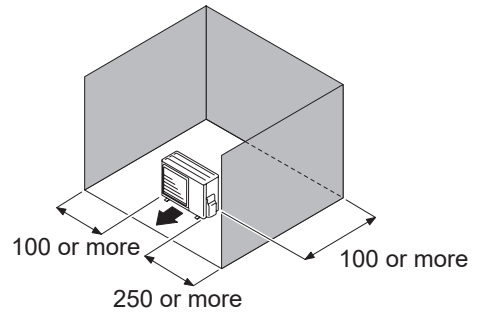

When there are obstacles at the front only.

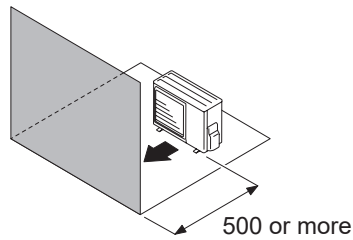

When there are obstacles at the front and rear.

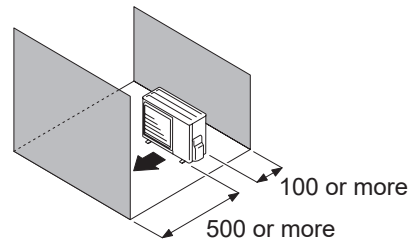

- When there is an obstruction in the upper space:

Unit: mm

When there are obstacles at the rear and above.

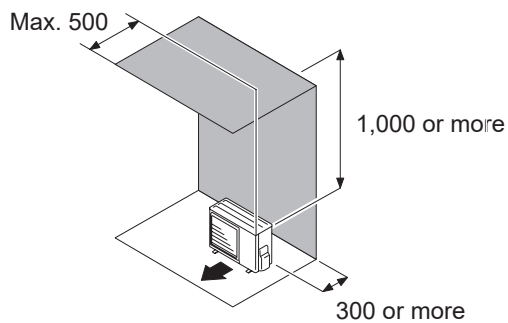

When there are obstacles at the rear, sides, and above.

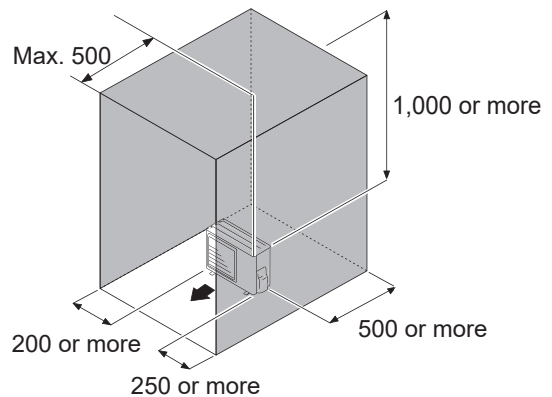

# Multiple outdoor unit installation

- When the upper space is open:

Unit: mm

When there are obstacles at the rear only.

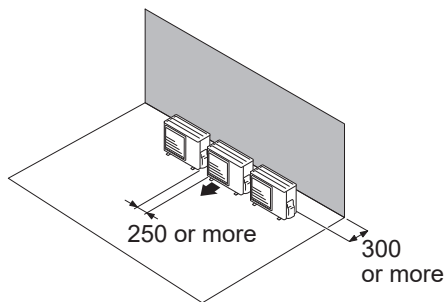

When there are obstacles at the front only.

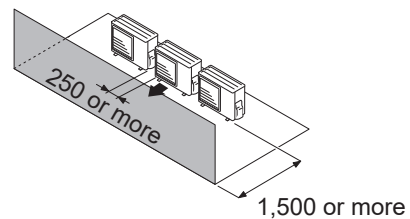

When there are obstacles at the front and rear.

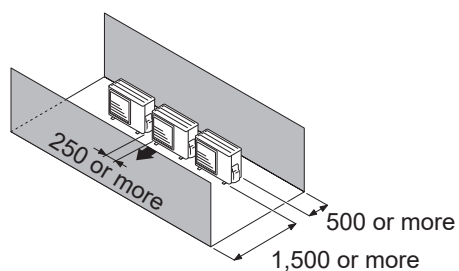

- When there is an obstruction in the upper space:

Unit: mm

When there are obstacles at the rear and above.

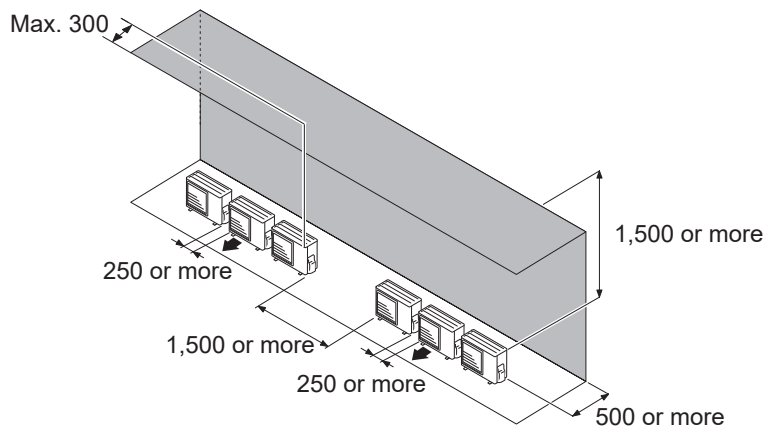

# Outdoor unit installation in multi-row

Unit: mm

Single parallel unit arrangement

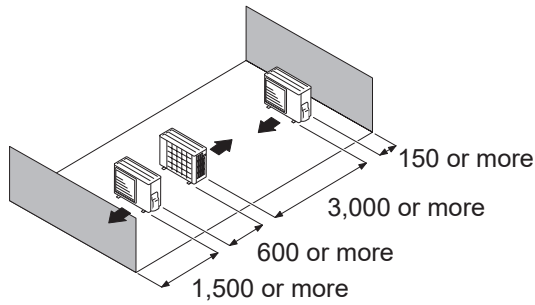

Multiple parallel unit arrangement

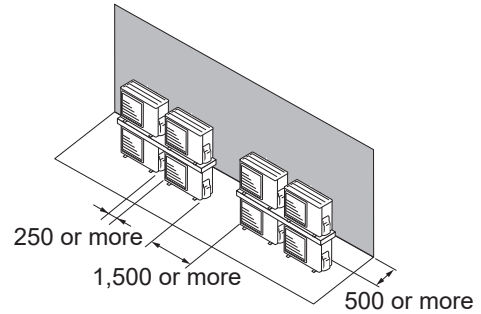
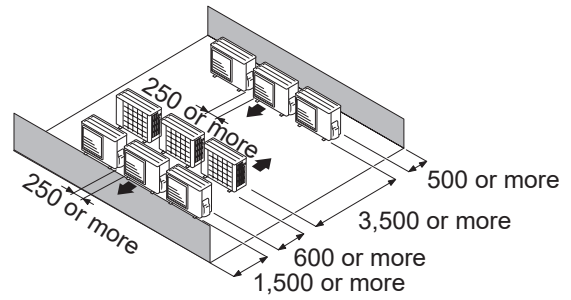

## NOTES:

- If the space is larger than stated above, the condition will be the same as when there is no obstacle.
- Height above the floor level should be 50 mm or more.
- When installing the outdoor unit, be sure to open the front and left side to obtain better operation efficiency.

## ⚠ CAUTION

- Do not install the outdoor unit in two-stage where the drain water could freeze. Otherwise the drainage from the upper unit may form ice and cause a malfunction of the lower unit.
- When the outdoor temperature is 0 °C or less, do not use the accessory drain pipe and drain cap. If the drain pipe and drain cap are used, the drain water in the pipe may freeze in extremely cold climate. (For reverse cycle model only.)
- In area with heavy snowfall, if the inlet and outlet of the outdoor unit is blocked with snow, it might become difficult to get warm, and it is likely to cause product malfunction. Construct a canopy and a pedestal, or place the unit on a high stand that is locally installed.

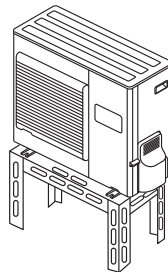

# Refrigerant circuit

## Models: AOYG24KBTB and AOYG30KBTB

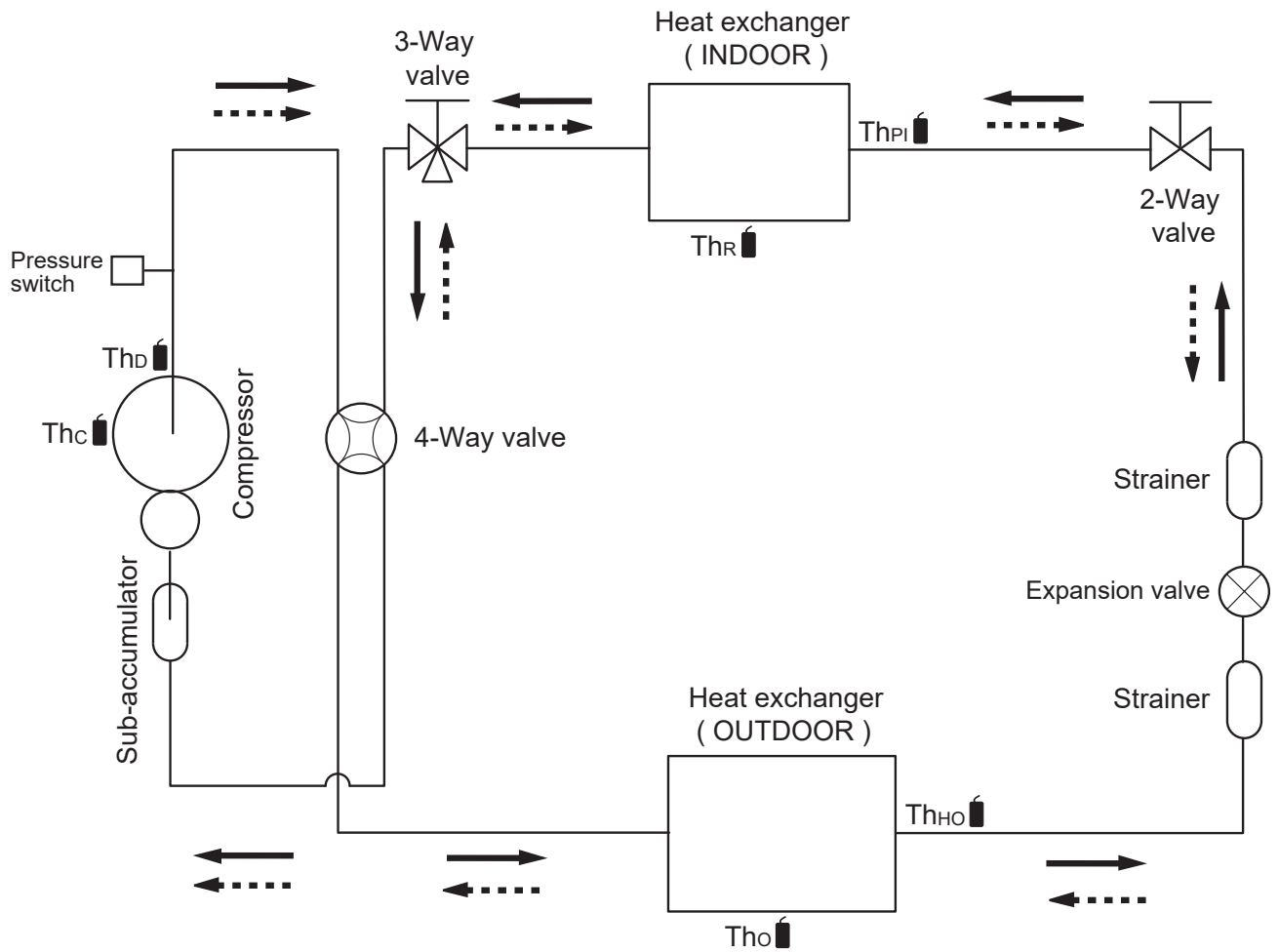

—————> : Cooling  
 .....> : Heating

- $Th_c$  : Thermistor (Compressor temperature)
- $Th_D$  : Thermistor (Discharge temperature)
- $Th_o$  : Thermistor (Outdoor temperature)
- $Th_{HO}$  : Thermistor (Heat Exchanger Out temperature)
- $Th_R$  : Thermistor (Room temperature)
- $Th_{PI}$  : Thermistor (Pipe temperature)

# Models: AOYG36KBTB, AOYG45KBTB, and AOYG54KBTB

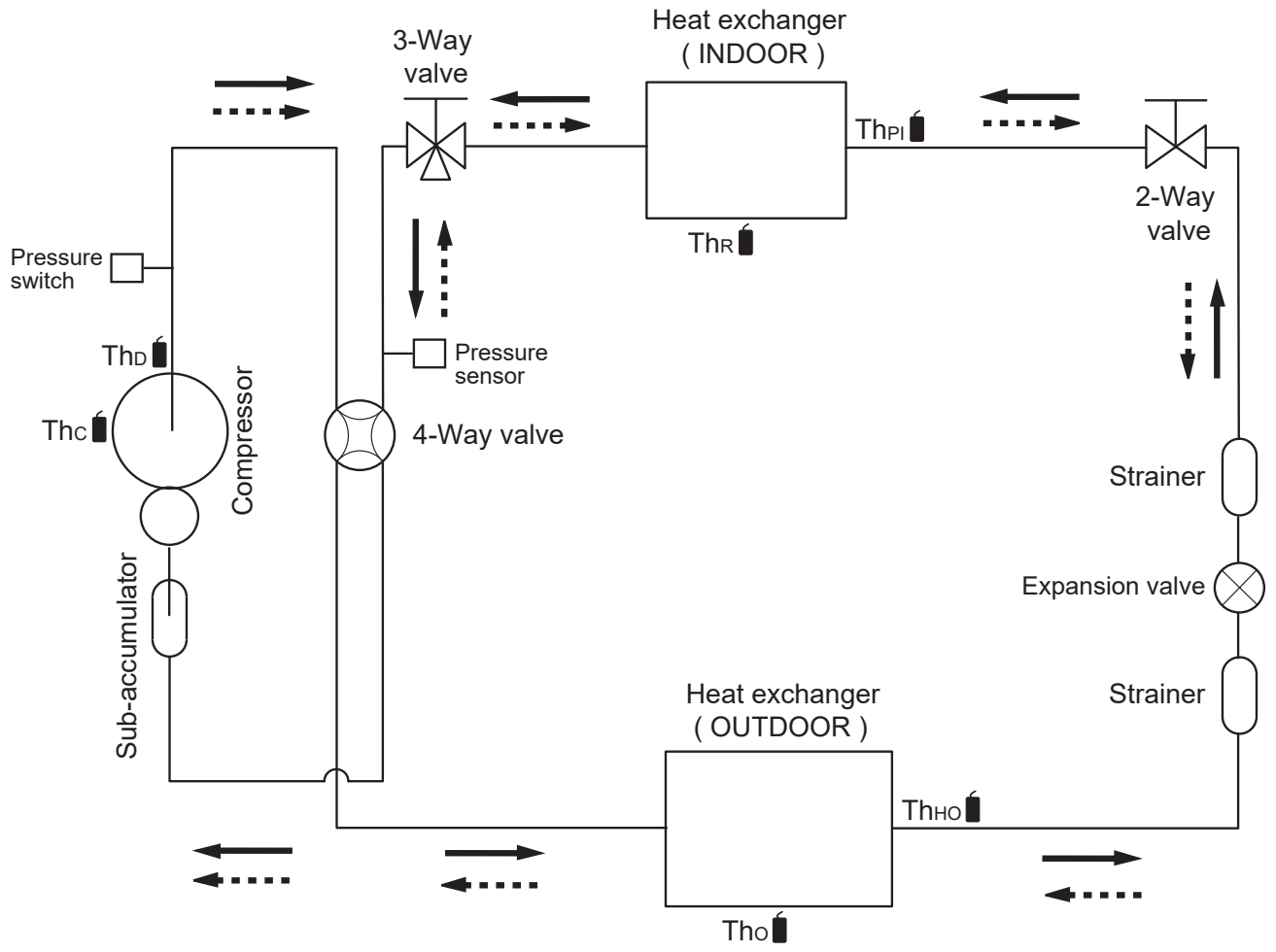

———→ : Cooling  
 .....→ : Heating

- $Th_c$  : Thermistor (Compressor temperature)
- $Th_d$  : Thermistor (Discharge temperature)
- $Th_o$  : Thermistor (Outdoor temperature)
- $Th_{HO}$  : Thermistor (Heat Exchanger Out temperature)
- $Th_R$  : Thermistor (Room temperature)
- $Th_{PI}$  : Thermistor (Pipe temperature)

# INDOOR PRINTED CIRCUIT BOARD CIRCUIT DIAGRAM

Modes : ARXG24KHTAP

## CONTROL UNIT EZ-0182AHSE

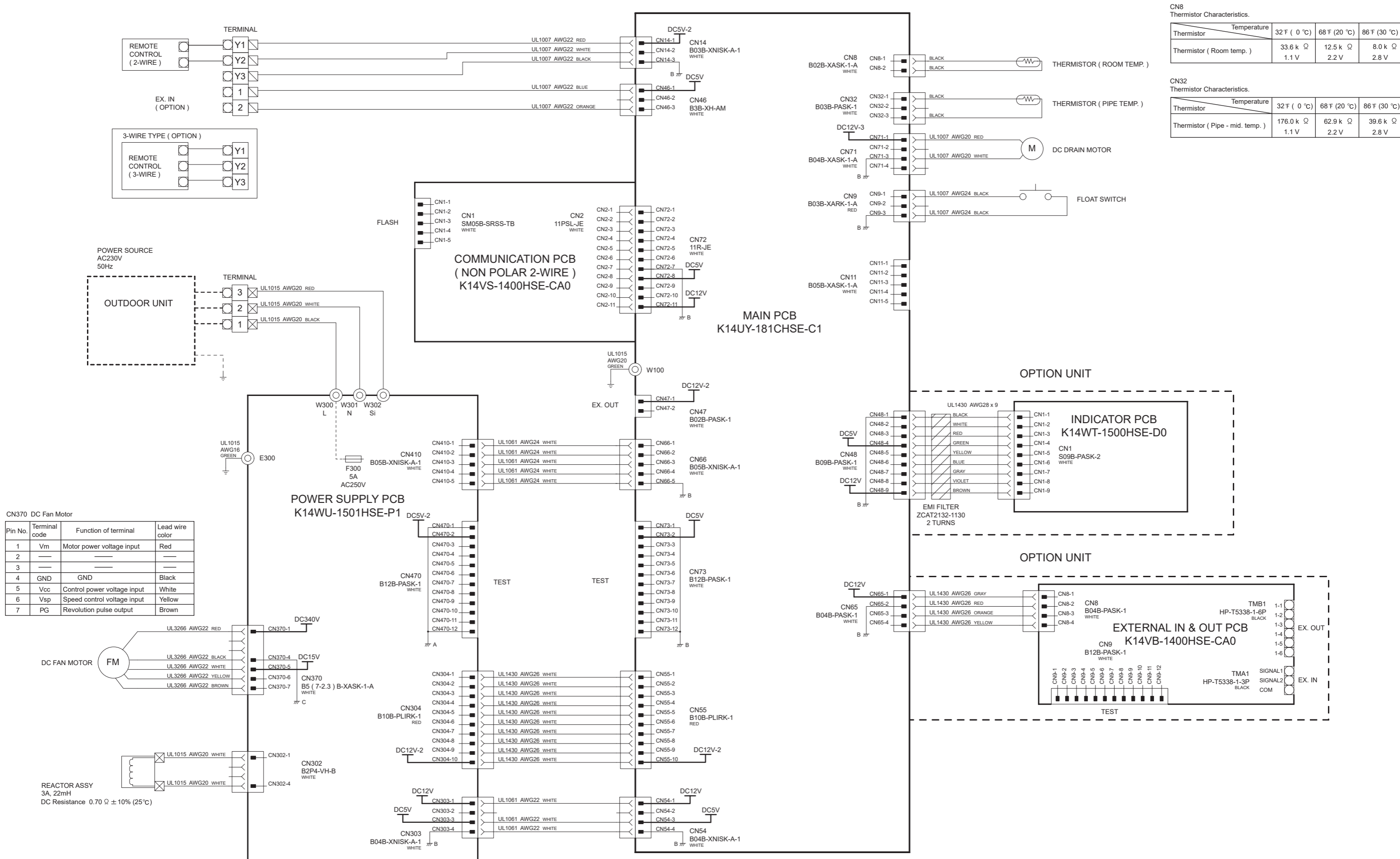

CN8 Thermistor Characteristics.

Thermistor	Temperature	32 F ( 0 °C)	68 F (20 °C)	86 F (30 °C)
Thermistor ( Room temp. )		33.6 k Ω	12.5 k Ω	8.0 k Ω
		1.1 V	2.2 V	2.8 V

CN32 Thermistor Characteristics.

Thermistor	Temperature	32 F ( 0 °C)	68 F (20 °C)	86 F (30 °C)
Thermistor ( Pipe - mid. temp. )		176.0 k Ω	62.9 k Ω	39.6 k Ω
		1.1 V	2.2 V	2.8 V

CN370 DC Fan Motor

Pin No.	Terminal code	Function of terminal	Lead wire color
1	Vm	Motor power voltage input	Red
2	—	—	—
3	—	—	—
4	GND	GND	Black
5	Vcc	Control power voltage input	White
6	Vsp	Speed control voltage input	Yellow
7	PG	Revolution pulse output	Brown

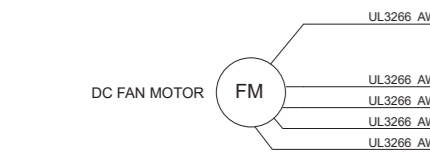

REACTOR ASSY  
3A, 22mH  
DC Resistance 0.70 Ω ± 10% (25°C)



Models : ARXG30KHTAP  
 ARXG36KHTAP  
 ARXG45KHTAP  
 ARXG54KHTAP

CONTROL UNIT  
 ARXG30KHTAP : EZ-0182BHSE  
 ARXG36KHTAP : EZ-0182CHSE  
 ARXG45KHTAP : EZ-0182DHSE  
 ARXG54KHTAP : EZ-0181MHSE

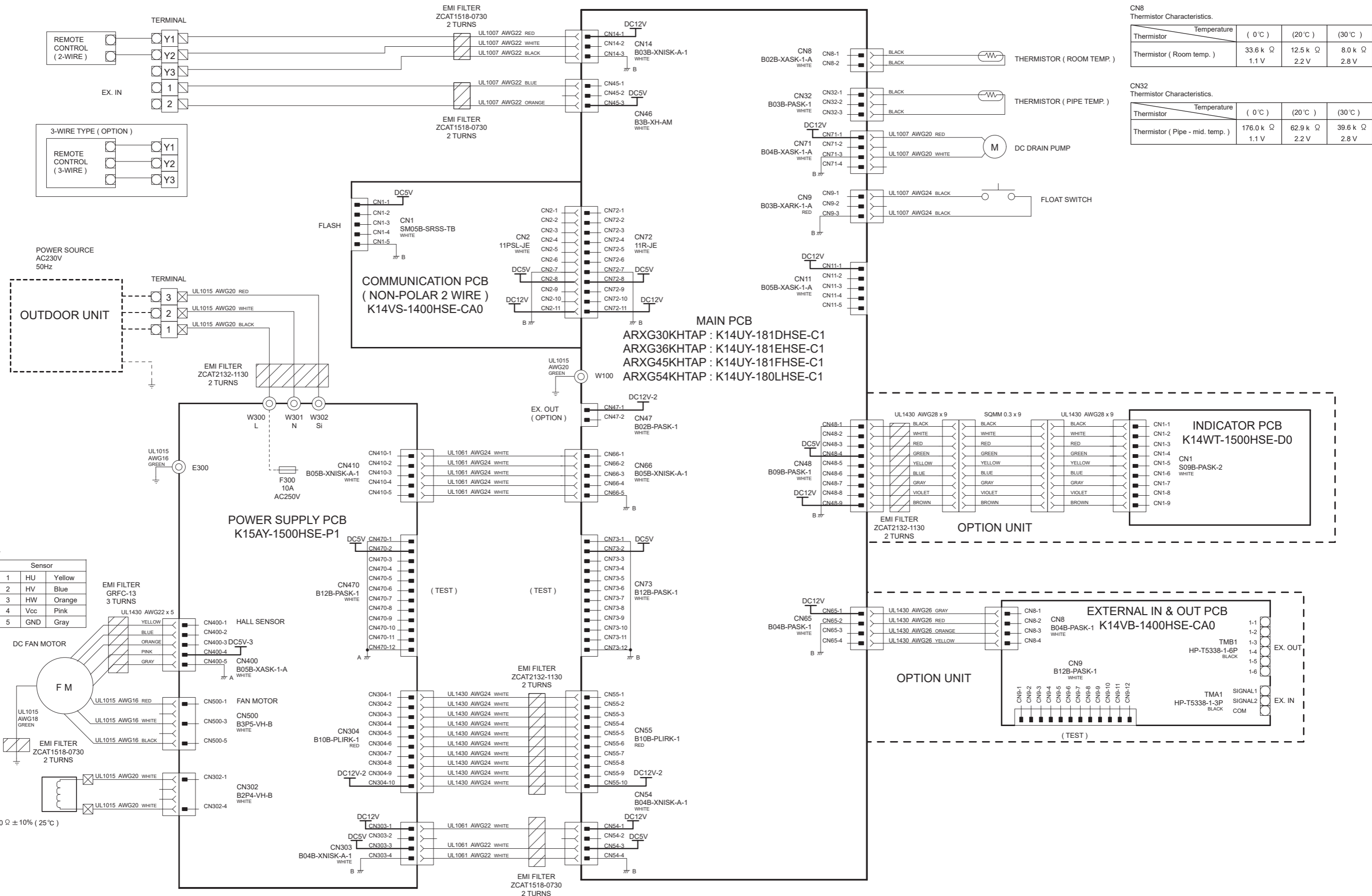

CN8 Thermistor Characteristics.

Thermistor	Temperature ( 0°C )	( 20°C )	( 30°C )
Thermistor ( Room temp. )	33.6 k Ω	12.5 k Ω	8.0 k Ω
	1.1 V	2.2 V	2.8 V

CN32 Thermistor Characteristics.

Thermistor	Temperature ( 0°C )	( 20°C )	( 30°C )
Thermistor ( Pipe - mid. temp. )	176.0 k Ω	62.9 k Ω	39.6 k Ω
	1.1 V	2.2 V	2.8 V

CN400, CN500 DC Fan motor

Power		Sensor			
1	U	Red	1	HU	Yellow
2	-	-	2	HV	Blue
3	V	White	3	HW	Orange
4	-	-	4	Vcc	Pink
5	W	Black	5	GND	Gray

# OUTDOOR PRINTED CIRCUIT BOARD CIRCUIT DIAGRAM

Model : AOYG24KBTB

INVERTER ASSEMBLY  
EZ-01801HUE

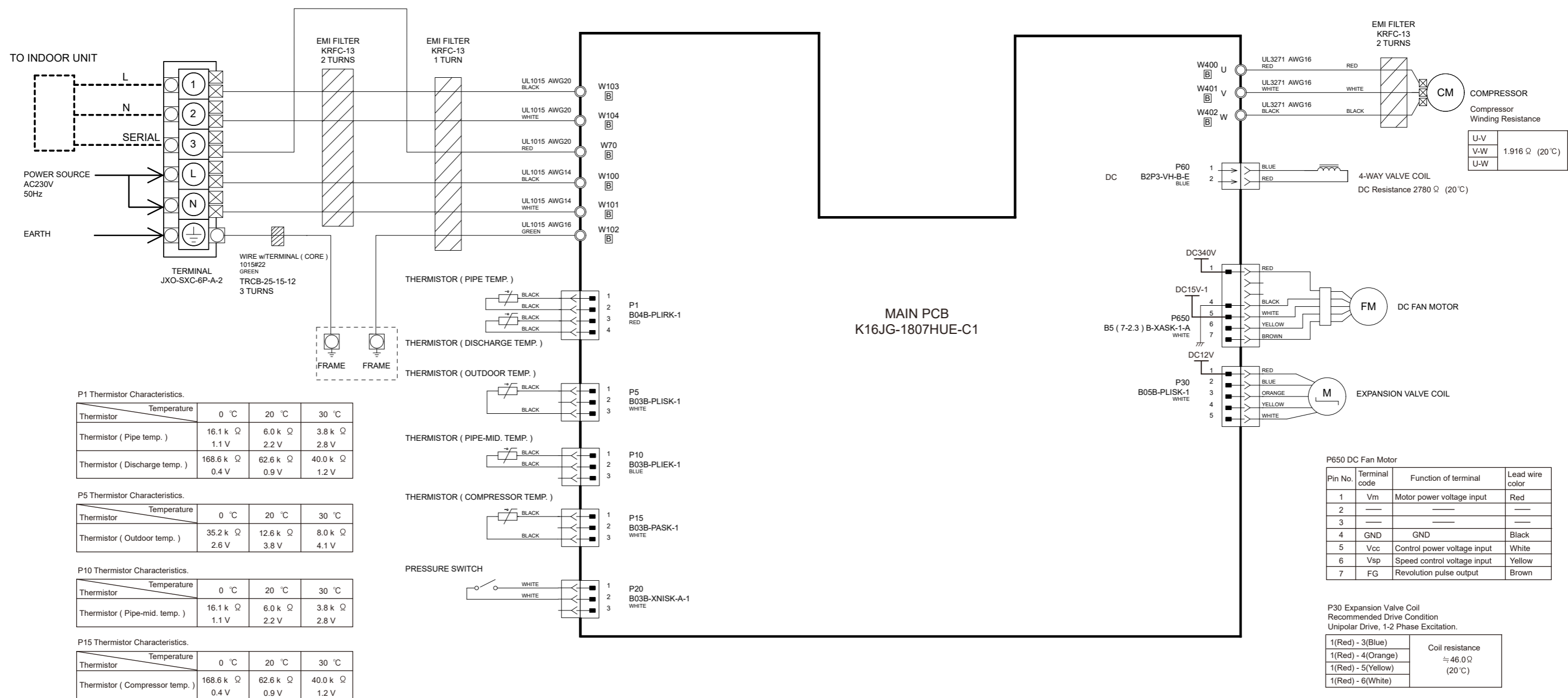

P1 Thermistor Characteristics.

Thermistor	Temperature	0 °C	20 °C	30 °C
Thermistor ( Pipe temp. )		16.1 k Ω	6.0 k Ω	3.8 k Ω
		1.1 V	2.2 V	2.8 V
Thermistor ( Discharge temp. )		168.6 k Ω	62.6 k Ω	40.0 k Ω
		0.4 V	0.9 V	1.2 V

P5 Thermistor Characteristics.

Thermistor	Temperature	0 °C	20 °C	30 °C
Thermistor ( Outdoor temp. )		35.2 k Ω	12.6 k Ω	8.0 k Ω
		2.6 V	3.8 V	4.1 V

P10 Thermistor Characteristics.

Thermistor	Temperature	0 °C	20 °C	30 °C
Thermistor ( Pipe-mid. temp. )		16.1 k Ω	6.0 k Ω	3.8 k Ω
		1.1 V	2.2 V	2.8 V

P15 Thermistor Characteristics.

Thermistor	Temperature	0 °C	20 °C	30 °C
Thermistor ( Compressor temp. )		168.6 k Ω	62.6 k Ω	40.0 k Ω
		0.4 V	0.9 V	1.2 V

P650 DC Fan Motor

Pin No.	Terminal code	Function of terminal	Lead wire color
1	Vm	Motor power voltage input	Red
2	—	—	—
3	—	—	—
4	GND	GND	Black
5	Vcc	Control power voltage input	White
6	Vsp	Speed control voltage input	Yellow
7	FG	Revolution pulse output	Brown

P30 Expansion Valve Coil  
Recommended Drive Condition  
Unipolar Drive, 1-2 Phase Excitation.

1(Red) - 3(Blue)	Coil resistance ≈ 46.0 Ω (20 °C)
1(Red) - 4(Orange)	
1(Red) - 5(Yellow)	
1(Red) - 6(White)	

Compressor Winding Resistance

U-V	1.916 Ω (20 °C)
V-W	
U-W	

P30 Expansion Valve Coil  
Recommended Drive Condition  
Unipolar Drive, 1-2 Phase Excitation.

1(Red) - 3(Blue)	Coil resistance ≈ 46.0 Ω (20 °C)
1(Red) - 4(Orange)	
1(Red) - 5(Yellow)	
1(Red) - 6(White)	

INVERTER ASSEMBLY  
EZ-0182AHUE

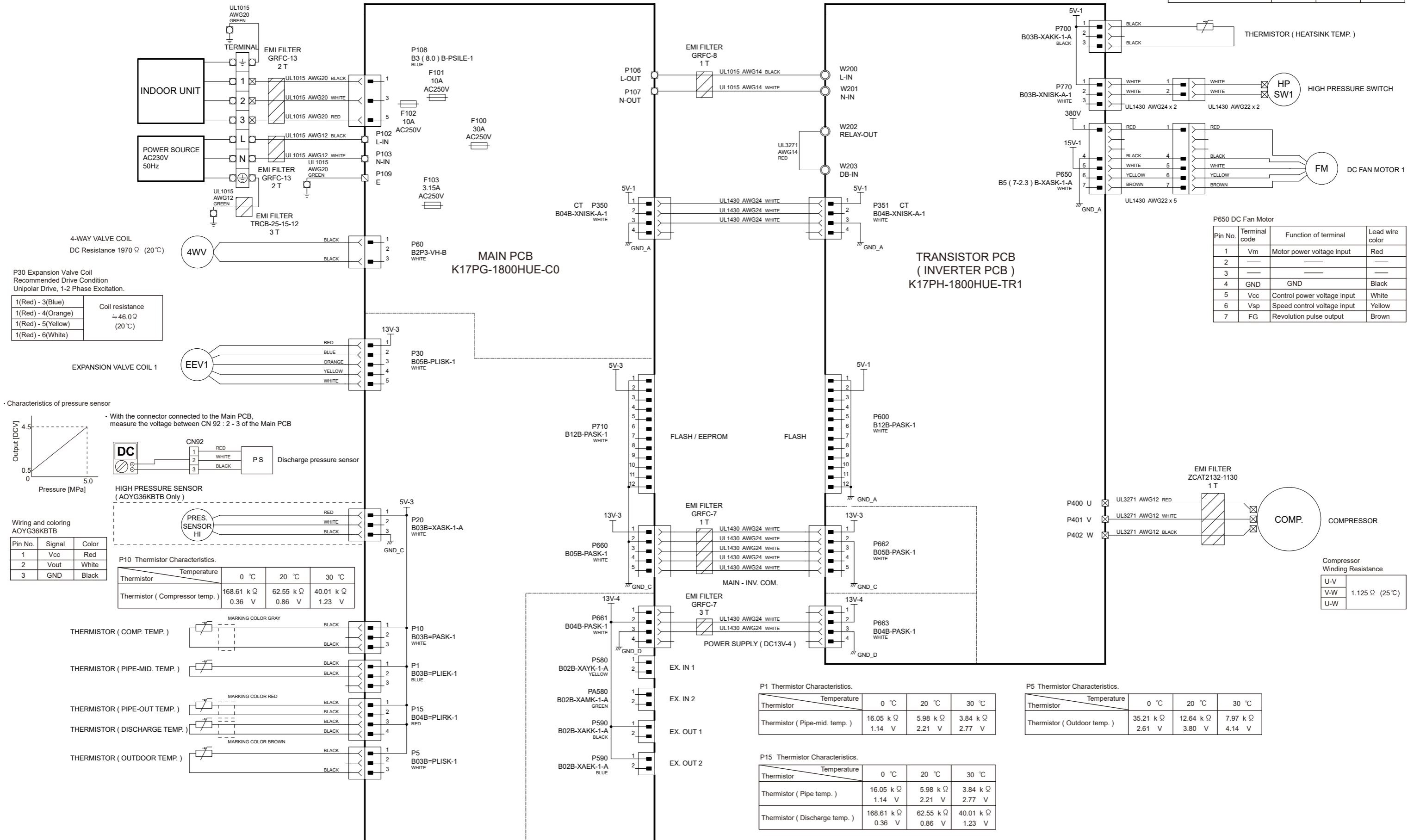

P700 Thermistor Characteristics.

Thermistor	Temperature	0 °C	20 °C	30 °C
Thermistor		0.33 k Ω	0.12 k Ω	0.08 k Ω
Thermistor ( Heatsink temp. )		4.10 V	4.62 V	4.75 V

P650 DC Fan Motor

Pin No.	Terminal code	Function of terminal	Lead wire color
1	Vm	Motor power voltage input	Red
2			
3			
4	GND	GND	Black
5	Vcc	Control power voltage input	White
6	Vsp	Speed control voltage input	Yellow
7	FG	Revolution pulse output	Brown

4-Way Valve Coil Characteristics

Coil resistance	Temperature
≈ 46.0 Ω	(20 °C)

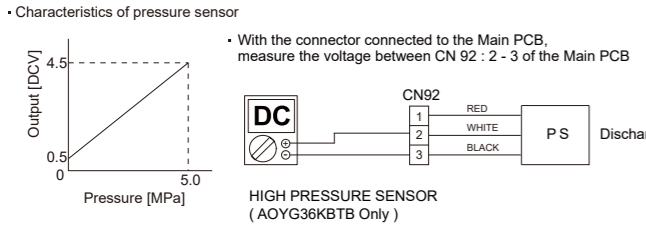

Wiring and coloring AOYG36KBTB

Pin No.	Signal	Color
1	Vcc	Red
2	Vout	White
3	GND	Black

P10 Thermistor Characteristics.

Thermistor	Temperature	0 °C	20 °C	30 °C
Thermistor ( Compressor temp. )		168.61 k Ω	62.55 k Ω	40.01 k Ω
		0.36 V	0.86 V	1.23 V

P1 Thermistor Characteristics.

Thermistor	Temperature	0 °C	20 °C	30 °C
Thermistor ( Pipe-mid. temp. )		16.05 k Ω	5.98 k Ω	3.84 k Ω
		1.14 V	2.21 V	2.77 V

P5 Thermistor Characteristics.

Thermistor	Temperature	0 °C	20 °C	30 °C
Thermistor ( Outdoor temp. )		35.21 k Ω	12.64 k Ω	7.97 k Ω
		2.61 V	3.80 V	4.14 V

P15 Thermistor Characteristics.

Thermistor	Temperature	0 °C	20 °C	30 °C
Thermistor ( Pipe temp. )		16.05 k Ω	5.98 k Ω	3.84 k Ω
		1.14 V	2.21 V	2.77 V
Thermistor ( Discharge temp. )		168.61 k Ω	62.55 k Ω	40.01 k Ω
		0.36 V	0.86 V	1.23 V

Compressor Winding Resistance

U-V	1.125 Ω (25°C)
V-W	
U-W	

INVERTER ASSEMBLY  
EZ-0182BHUE

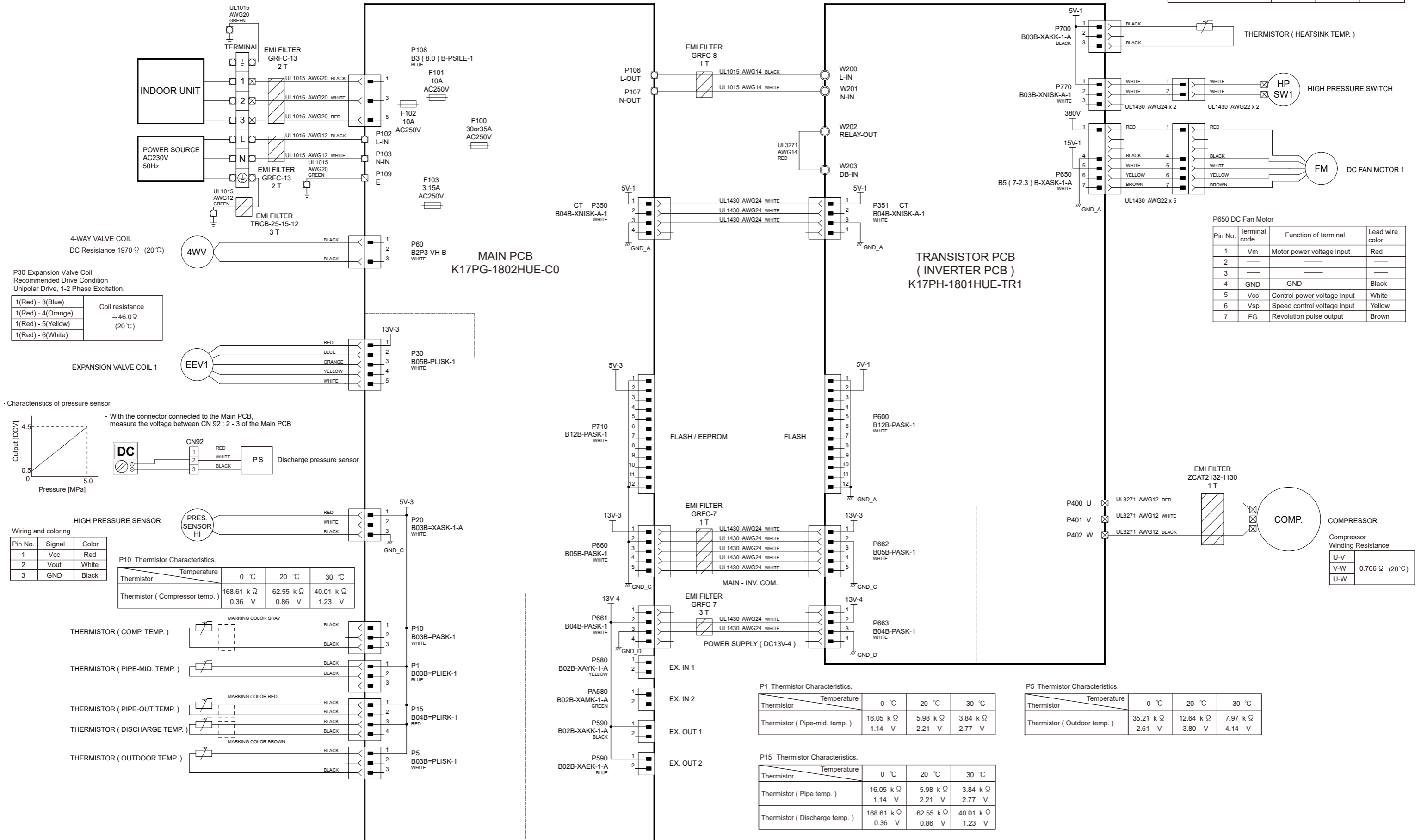

P700 Thermistor Characteristics.

Thermistor	Temperature	0 °C	20 °C	30 °C
Thermistor		0.33 k Ω	0.12 k Ω	0.08 k Ω
Thermistor ( Heatsink temp. )		4.10 V	4.62 V	4.75 V

P650 DC Fan Motor

Pin No.	Terminal code	Function of terminal	Lead wire color
1	Vm	Motor power voltage input	Red
2			
3			
4	GND	GND	Black
5	Vcc	Control power voltage input	White
6	Vsp	Speed control voltage input	Yellow
7	FG	Revolution pulse output	Brown

4-WAY VALVE COIL  
DC Resistance 1970 Ω (20 °C)

Coil resistance	Temperature
1(Red) - 3(Blue)	≈ 46.0 Ω (20 °C)
1(Red) - 4(Orange)	
1(Red) - 5(Yellow)	
1(Red) - 6(White)	

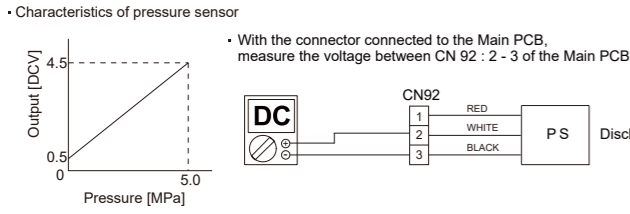

Wiring and coloring

Pin No.	Signal	Color
1	Vcc	Red
2	Vout	White
3	GND	Black

P10 Thermistor Characteristics.

Thermistor	Temperature	0 °C	20 °C	30 °C
Thermistor		168.61 k Ω	62.55 k Ω	40.01 k Ω
Thermistor ( Compressor temp. )		0.36 V	0.86 V	1.23 V

P1 Thermistor Characteristics.

Thermistor	Temperature	0 °C	20 °C	30 °C
Thermistor		16.05 k Ω	5.98 k Ω	3.84 k Ω
Thermistor ( Pipe-mid. temp. )		1.14 V	2.21 V	2.77 V

P5 Thermistor Characteristics.

Thermistor	Temperature	0 °C	20 °C	30 °C
Thermistor		35.21 k Ω	12.64 k Ω	7.97 k Ω
Thermistor ( Outdoor temp. )		2.61 V	3.80 V	4.14 V

P15 Thermistor Characteristics.

Thermistor	Temperature	0 °C	20 °C	30 °C
Thermistor		16.05 k Ω	5.98 k Ω	3.84 k Ω
Thermistor ( Pipe temp. )		1.14 V	2.21 V	2.77 V
Thermistor ( Discharge temp. )		168.61 k Ω	62.55 k Ω	40.01 k Ω
		0.36 V	0.86 V	1.23 V

Compressor Winding Resistance

U-V	
V-W	0.766 Ω (20 °C)
U-W	

# Error codes ( Indoor unit )

## [Error displays at the remote controller LCD]

This is possible only on the wired remote controller.

### [Self-diagnosis]

If an error occurs, the following display will be shown. ("Er" will appear in the set room temperature display.)

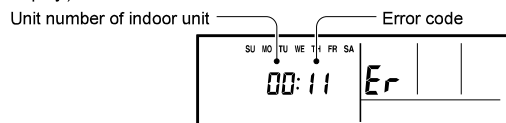

EX. Self-diagnosis

Wired remote controller Error code	Description
11	Serial communication error
12	Wired remote controller communication error
15	Check run unfinished
21	Unit number or Refrigerant circuit address setting error [Simultaneous Multi]
22	Indoor unit capacity error
23	Combination error
24	<ul style="list-style-type: none"> <li>• Connection unit number error (indoor secondary unit) [Simultaneous Multi]</li> <li>• Connection unit number error (indoor unit or branch unit) [Flexible Multi]</li> </ul>
27	Primary unit, secondary unit set-up error [Simultaneous Multi]
31	Power supply interruption error
32	Indoor unit PCB model information error
35	Manual auto switch error
41	Room temp. sensor error
42	Indoor unit Heat Ex. Middle temp. sensor error
51	Indoor unit fan motor error
53	Drain pump error
57	Damper error
5U	Indoor unit error
62	Outdoor unit main PCB model information error or communication error
63	Inverter error
64	Active filter error, PFC circuit error
65	Trip terminal L error
6A	Display PCB microcomputers communication error

Wired remote controller Error code	Description
71	Discharge temp. sensor error
72	Compressor temp. sensor error
73	Outdoor unit Heat Ex. liquid temp. sensor error
74	Outdoor temp. sensor error
75	Suction Gas temp. sensor error
76	<ul style="list-style-type: none"> <li>• 2-way valve temp. sensor error</li> <li>• 3-way valve temp. sensor error</li> </ul>
77	Heat sink temp. sensor error
82	<ul style="list-style-type: none"> <li>• Sub-cool Heat Ex. gas inlet temp. sensor error</li> <li>• Sub-cool Heat Ex. gas outlet temp. sensor error</li> </ul>
83	Liquid pipe temp. sensor error
84	Current sensor error
86	<ul style="list-style-type: none"> <li>• Discharge pressure sensor error</li> <li>• Suction pressure sensor error</li> <li>• High pressure switch error</li> </ul>
94	Trip detection
95	Compressor rotor position detection error (permanent stop)
97	Outdoor unit fan motor 1 error
98	Outdoor unit fan motor 2 error
99	4-way valve error
9A	Coil (expansion valve) error
A1	Discharge temp. error
A3	Compressor temp. error
A4	High pressure error
A5	Low pressure error
J2	Branch boxes error [Flexible Multi]

# Error codes ( Outdoor unit )

## AOHG30,36,45,54KBTB

You can determine the operating status by the lighting on and blinking of the LED display.

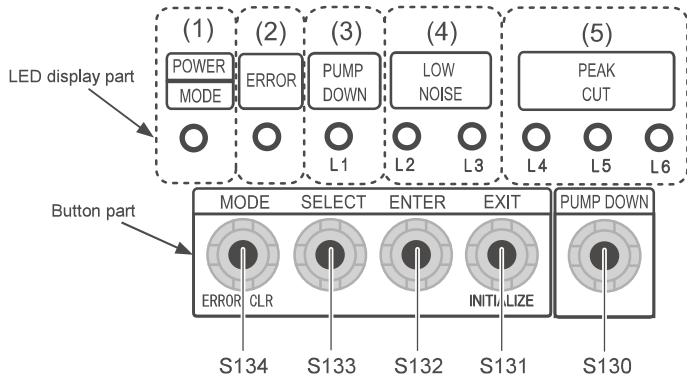

## Error display mode

Display when an error occurs.

POWER/ MODE	ERROR	PUMP DOWN (L1)	LOW NOISE		PEAK CUT		
			(L2)	(L3)	(L4)	(L5)	(L6)
●	Blink (Hi speed)	○	○	○	○	○	○

Sign "○": Lights off, "●": Lights on

- Check that the "ERROR" LED blinks, then press the [ENTER] button (S132) once.

## 10.2. Error code check table

DESCRIPTION	REMARK	LED display							
		POWER/ MODE	ERROR	PUMP DOWN (L1)	LOW NOISE		PEAK CUT		
					(L2)	(L3)	(L4)	(L5)	(L6)
Serial communication error	Serial forward transmission error immediately after operation	Blink (2 times)	●	Blink (1 time)	Blink (1 time)	○	○	●	●
	Serial forward transmission error during operation	Blink (2 times)	●	Blink (1 time)	Blink (1 time)	○	●	○	○
Indoor unit capacity error	Indoor unit capacity error	Blink (2 times)	●	Blink (2 times)	Blink (2 times)	○	○	○	●
Indoor unit error	Indoor unit error	Blink (2 times)	●	Blink (5 times)	Blink (15 times)	○	○	○	●
Outdoor unit main PCB error	Outdoor unit PCB model information error	Blink (2 times)	●	Blink (6 times)	Blink (2 times)	○	○	○	●
Inverter PCB error	Inverter error	Blink (2 times)	●	Blink (6 times)	Blink (3 times)	○	○	○	●
IPM error	Trip terminal L error	Blink (2 times)	●	Blink (6 times)	Blink (5 times)	○	○	●	●
Discharge temp. sensor error	Discharge temp. sensor 1 error	Blink (2 times)	●	Blink (7 times)	Blink (1 time)	○	○	○	●
Compressor temp. sensor error	Compressor temp. sensor 1 error	Blink (2 times)	●	Blink (7 times)	Blink (2 times)	○	○	○	●
Outdoor unit Heat Ex. sensor error	Heat Ex. center temp. sensor error	Blink (2 times)	●	Blink (7 times)	Blink (3 times)	○	○	●	○
	Outdoor unit Heat Ex. liquid temp. sensor error	Blink (2 times)	●	Blink (7 times)	Blink (3 times)	○	○	●	●
Outdoor temp. sensor error	Outdoor temp. sensor error	Blink (2 times)	●	Blink (7 times)	Blink (4 times)	○	○	○	●
Heat sink temp. sensor error	Heat sink temp. sensor error	Blink (2 times)	●	Blink (7 times)	Blink (7 times)	○	○	○	●
Current sensor error	Current sensor 1 error (stoppage permanently)	Blink (2 times)	●	Blink (8 times)	Blink (4 times)	○	○	○	●
Pressure sensor error	High pressure switch 1 error	Blink (2 times)	●	Blink (8 times)	Blink (6 times)	○	●	○	○
	Pressure sensor error	Blink (2 times)	●	Blink (8 times)	Blink (6 times)	○	●	●	○
Trip detection	Trip detection	Blink (2 times)	●	Blink (9 times)	Blink (4 times)	○	○	○	●
Compressor motor control error	Rotor position detection error (stoppage permanently)	Blink (2 times)	●	Blink (9 times)	Blink (5 times)	○	○	○	●
Outdoor unit fan motor 1 error	Duty abnormal	Blink (2 times)	●	Blink (9 times)	Blink (7 times)	○	○	●	●
Outdoor unit fan motor 2 error	Duty abnormal	Blink (2 times)	●	Blink (9 times)	Blink (8 times)	○	○	●	●
4-way valve error	4-way valve error	Blink (2 times)	●	Blink (9 times)	Blink (9 times)	○	○	○	●
Discharge temp. 1 error	Discharge temp. 1 error	Blink (2 times)	●	Blink (10 times)	Blink (1 time)	○	○	○	●
Compressor temp. error	Compressor 1 temp. error	Blink (2 times)	●	Blink (10 times)	Blink (3 times)	○	○	○	●
Pressure error 2	Low pressure error	Blink (2 times)	●	Blink (10 times)	Blink (5 times)	○	○	○	●
IPM error	Temp. error	Blink (2 times)	●	Blink (6 times)	Blink (5 times)	○	○	○	●
Heat sink temp. error	Heat sink temp. error	Blink (2 times)	●	Blink (10 times)	Blink (12 times)	○	○	●	●

# Parts

INDOOR UNIT  
ARXG24KHTAP  
ARXG30KHTAP

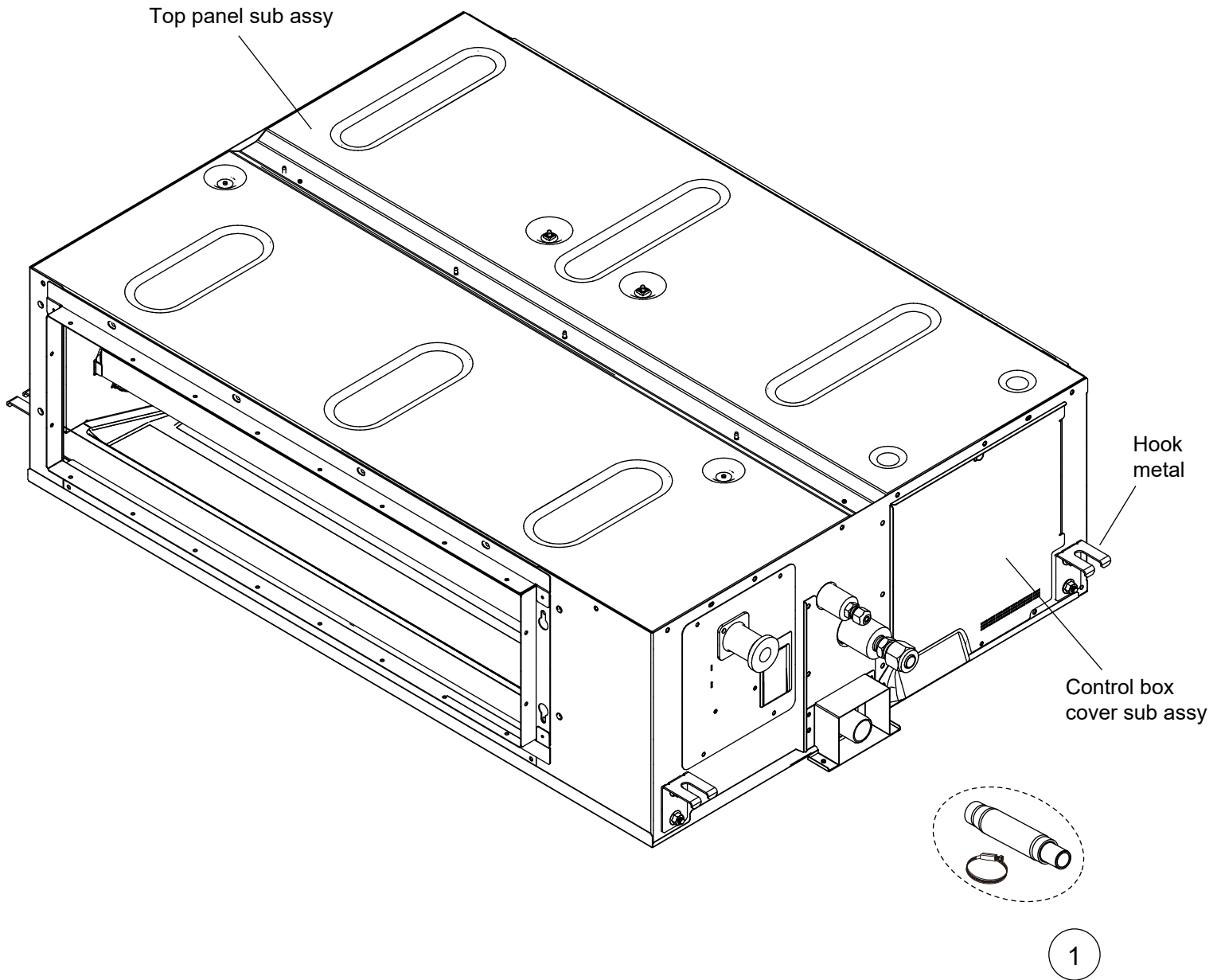

Ref.	Description	Part number
1	Hose sub assy	9378450196
2	Room thermistor	9703299278
3	Pipe thermistor	9900892005

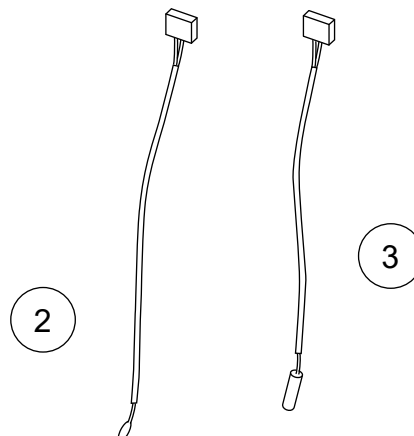

INDOOR UNIT  
ARXG24KHTAP  
ARXG30KHTAP

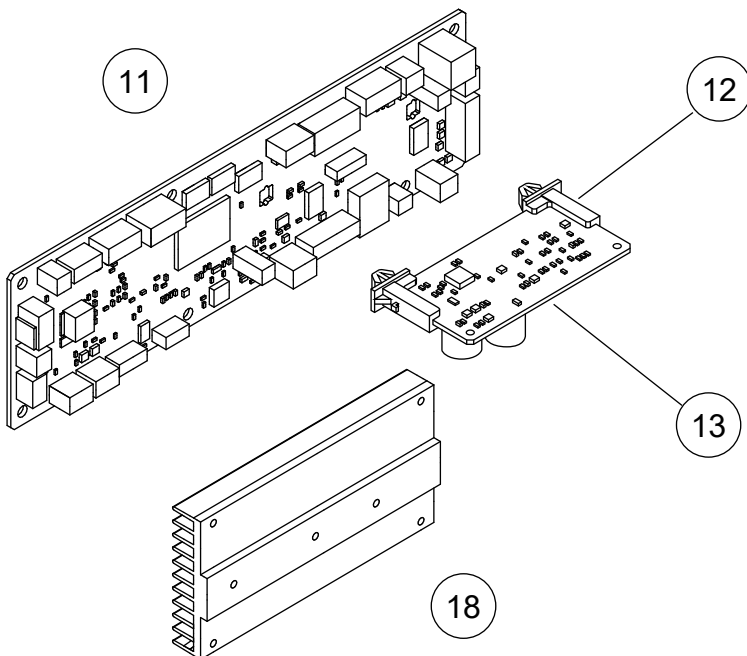
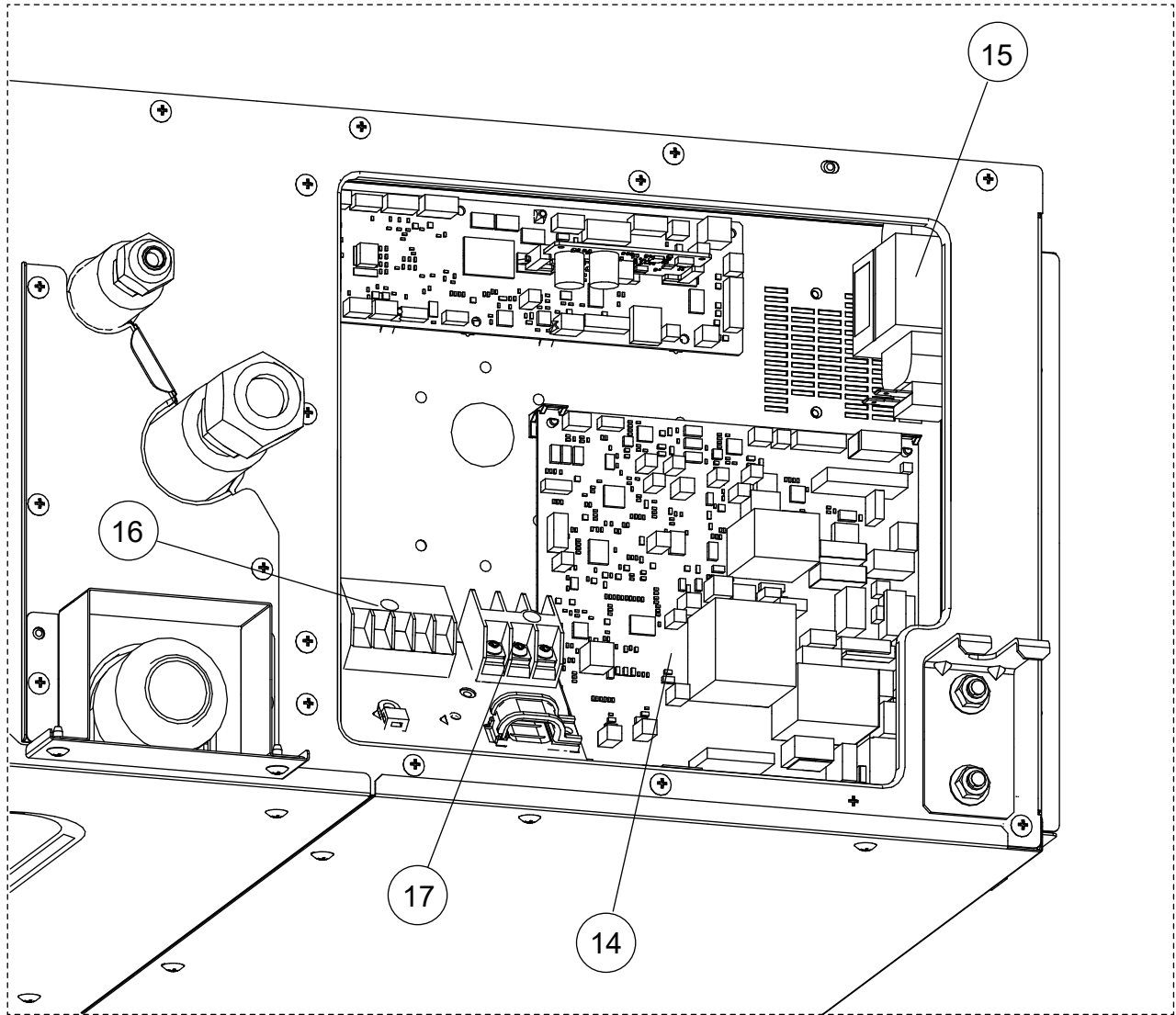

Ref.	Description	Part number
11	Main PCB (24KHTAP)	9710995927
11	Main PCB (30KHTAP)	9710995934
12	Holder	0600063023
13	Communication PCB	9710019005
14	Power Supply PCB (24)	9710032011
14	Power Supply PCB (30)	9710261008
15	Reactor Assy	9900898014
16	Terminal (Remote)	9900896003
17	Terminal (Power)	9900568009
18	Heatsink (30KHTAP)	9381518005



INDOOR UNIT  
ARXG24KHTAP  
ARXG30KHTAP

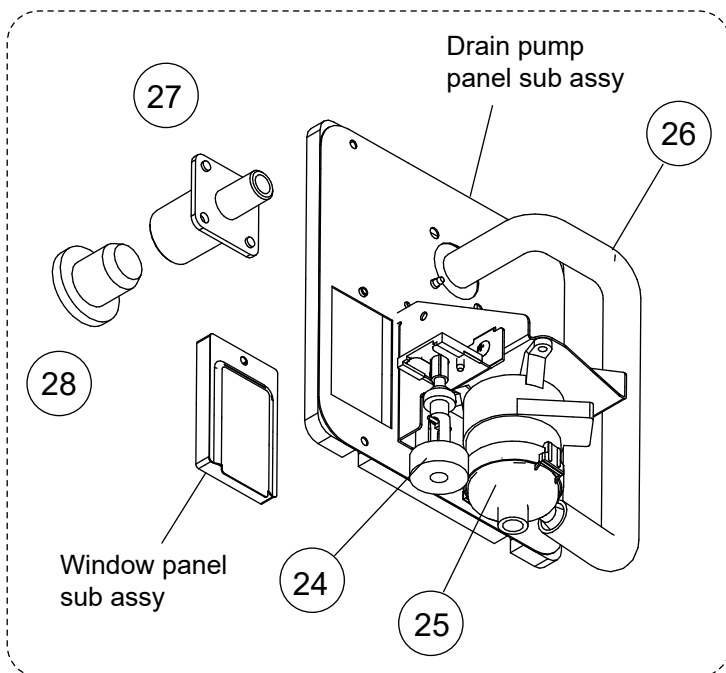
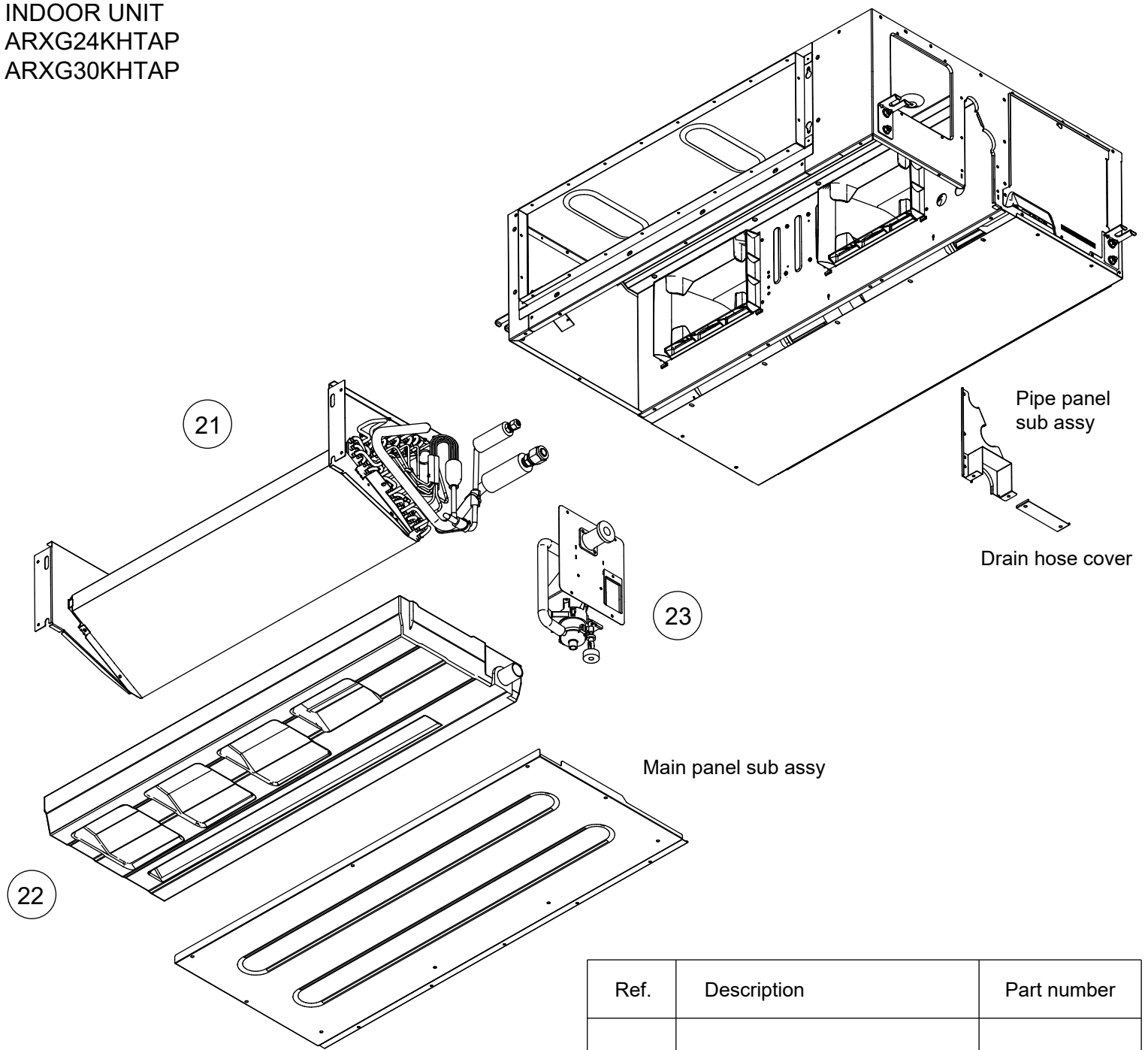

Ref.	Description	Part number
21	Evaporator Total Assy (24)	9383816062
21	Evaporator Total Assy (30)	9383816055
22	Drain Pan Sub Assy	9381752027
23	Drain Pump Sub Assy	9381766017
24	Float Switch	9900465070
25	Pump Assy	9900890018
26	Drain Hose	9381576005
27	Drain Port	9381565009
28	Drain Cap	9381578009

INDOOR UNIT  
ARXG24KHTAP  
ARXG30KHTAP

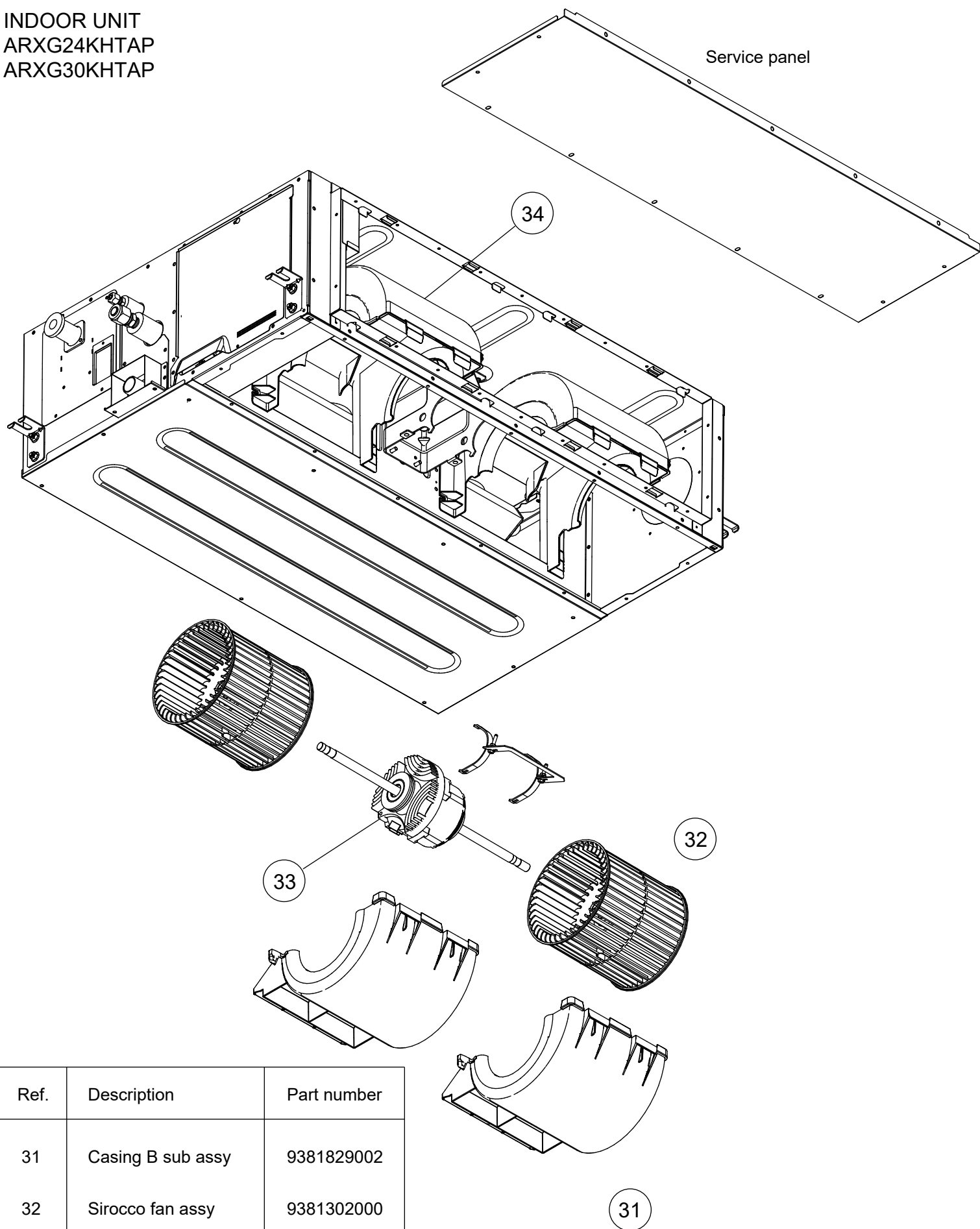

Ref.	Description	Part number
31	Casing B sub assy	9381829002
32	Sirocco fan assy	9381302000
33	Fan motor (24KHTAP)	9603479015
33	Fan motor (30KHTAP)	9603481018
34	Casing A	9381587001

INDOOR UNIT  
ARXG24KHTAP  
ARXG30KHTAP

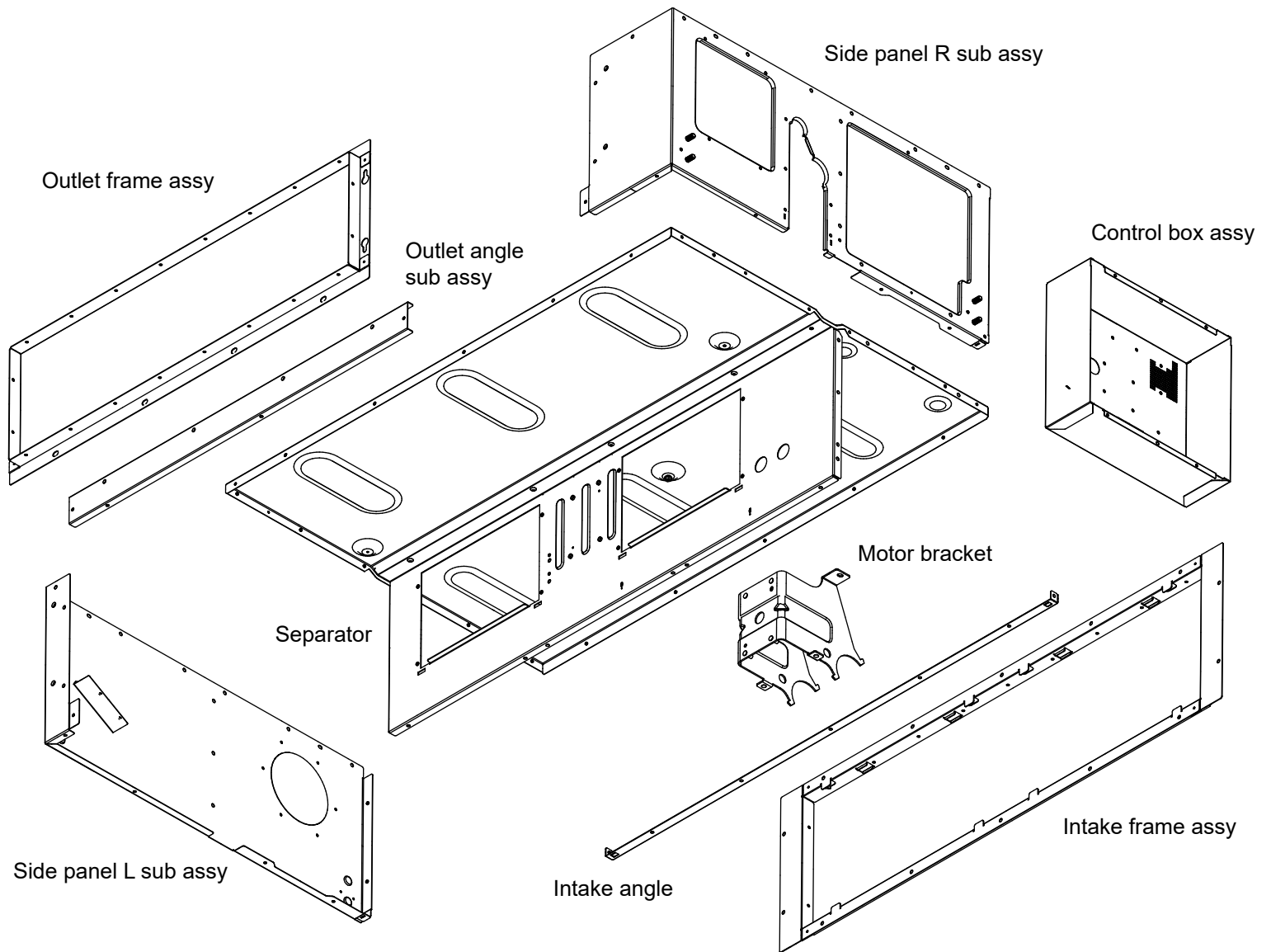

# PARTS

INDOOR UNIT  
 ARXG36KHTAP  
 ARXG45KHTAP  
 ARXG54KHTAP

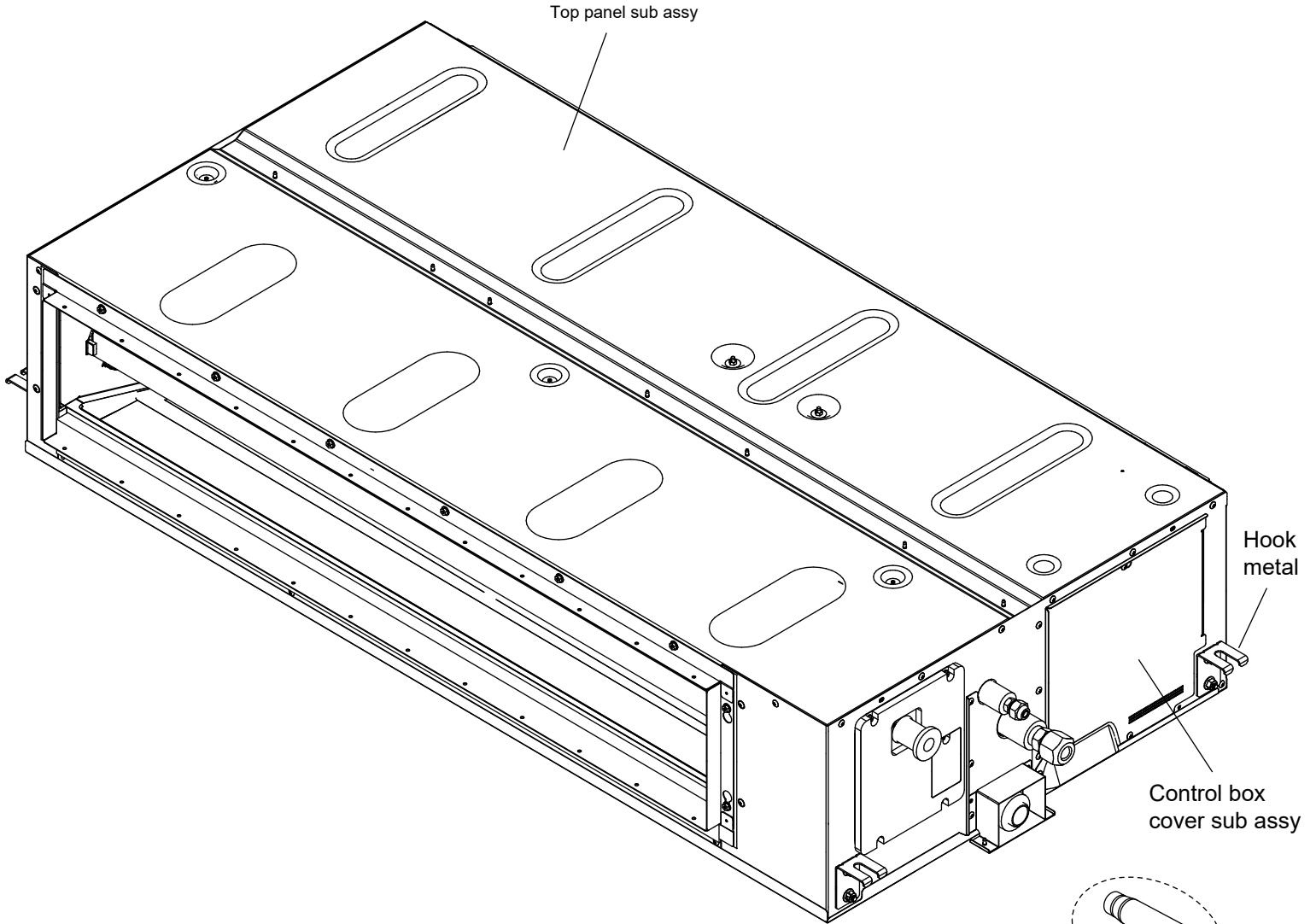

Ref.	Description	Part number
1	Hose sub assy	9378450196
2	Room thermistor	9703299278
3	Pipe thermistor	9900892005

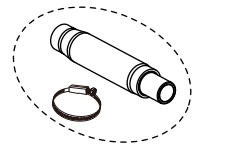

1

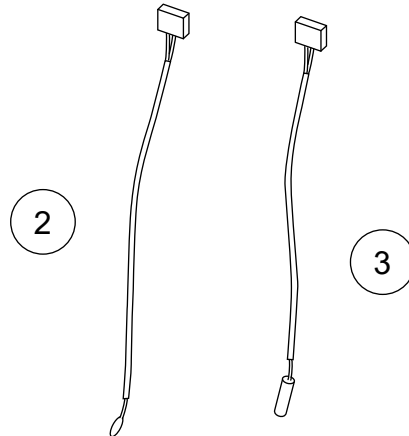

2

3

INDOOR UNIT  
 ARXG36KHTAP  
 ARXG45KHTAP  
 ARXG54KHTAP

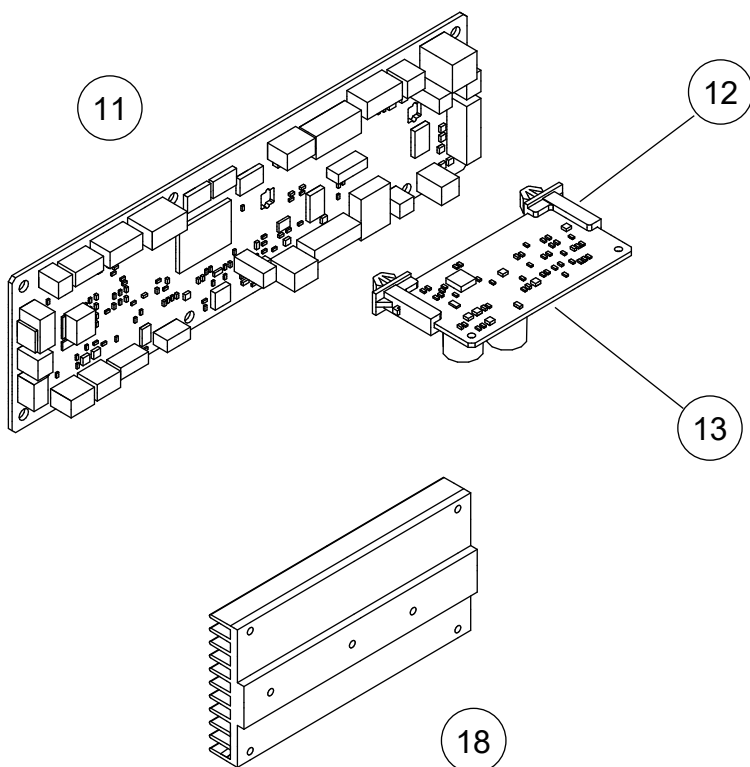
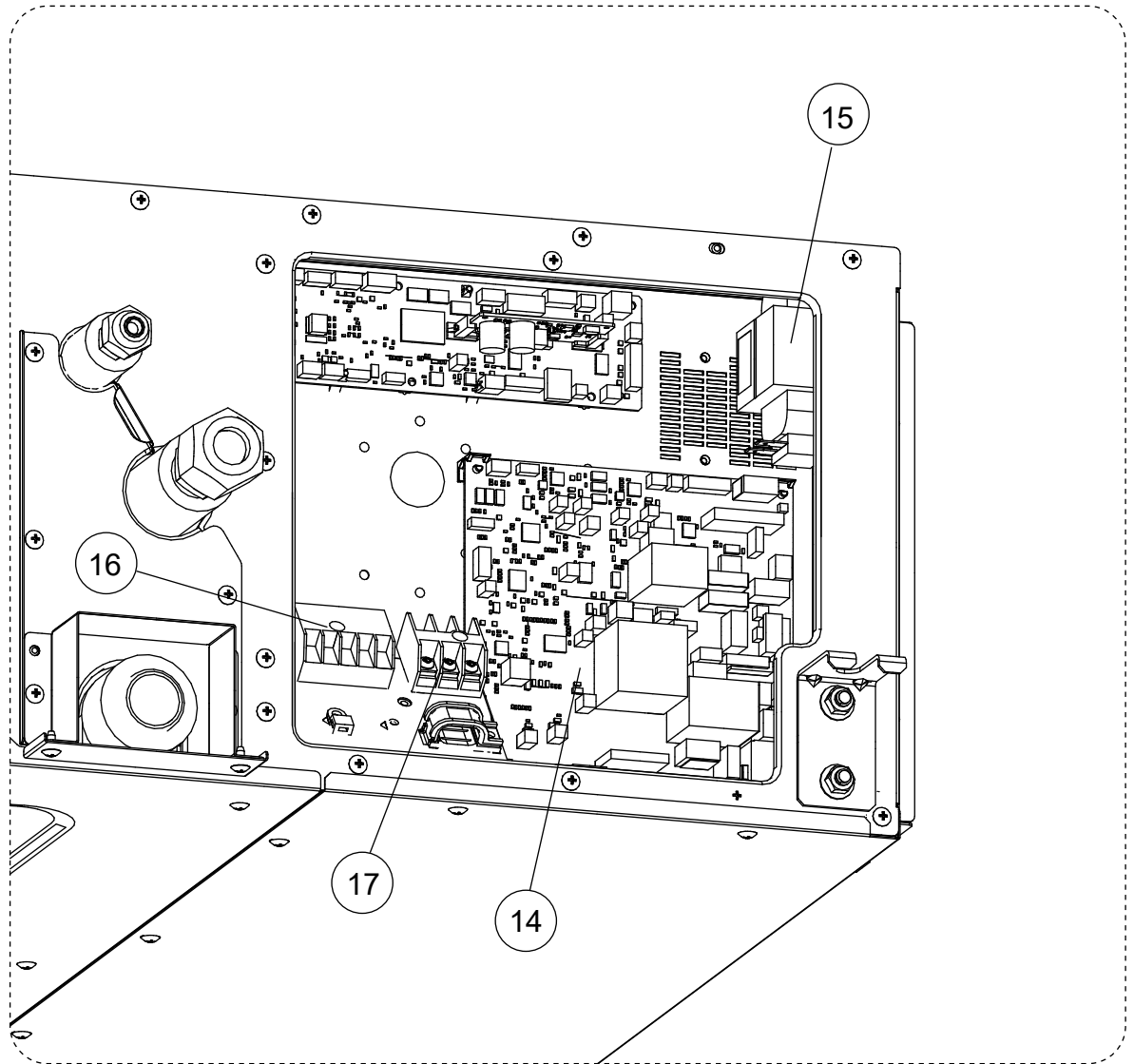

Ref.	Description	Part number
11	Main PCB (36KHTAP)	9710995941
11	Main PCB (45KHTAP)	9710995958
11	Main PCB (54KHTAP)	9710995729
12	Holder	0600063023
13	Communication PCB	9710019005
14	Power Supply PCB	9710261008
15	Reactor Assy	9900898014
16	Terminal (Remote)	9900896003
17	Terminal (Power)	9900568009
18	Heatsink	9381518005

INDOOR UNIT  
 ARXG36KHTAP  
 ARXG45KHTAP  
 ARXG54KHTAP

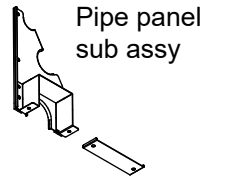
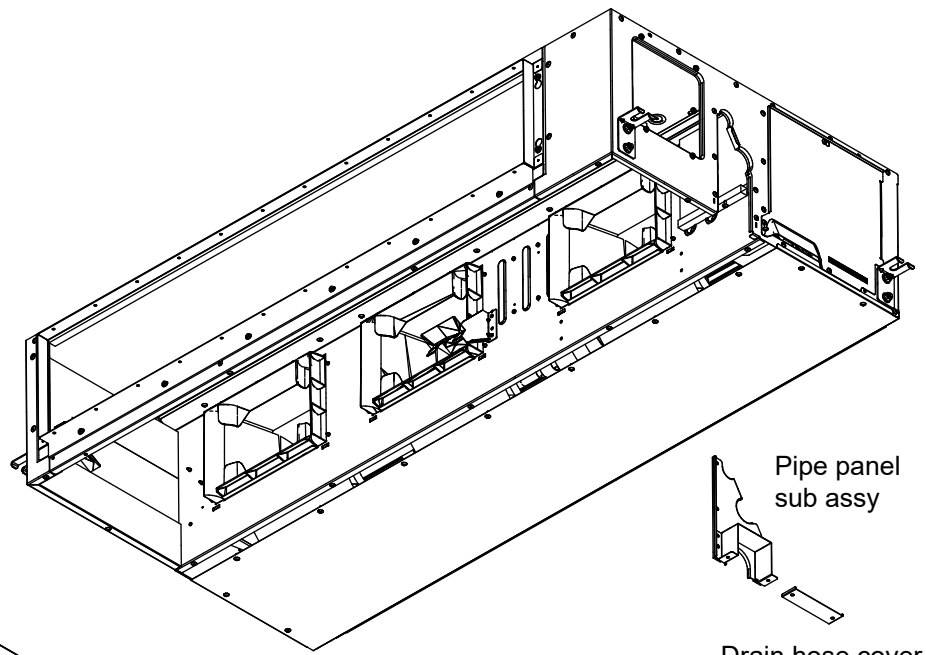

Drain hose cover

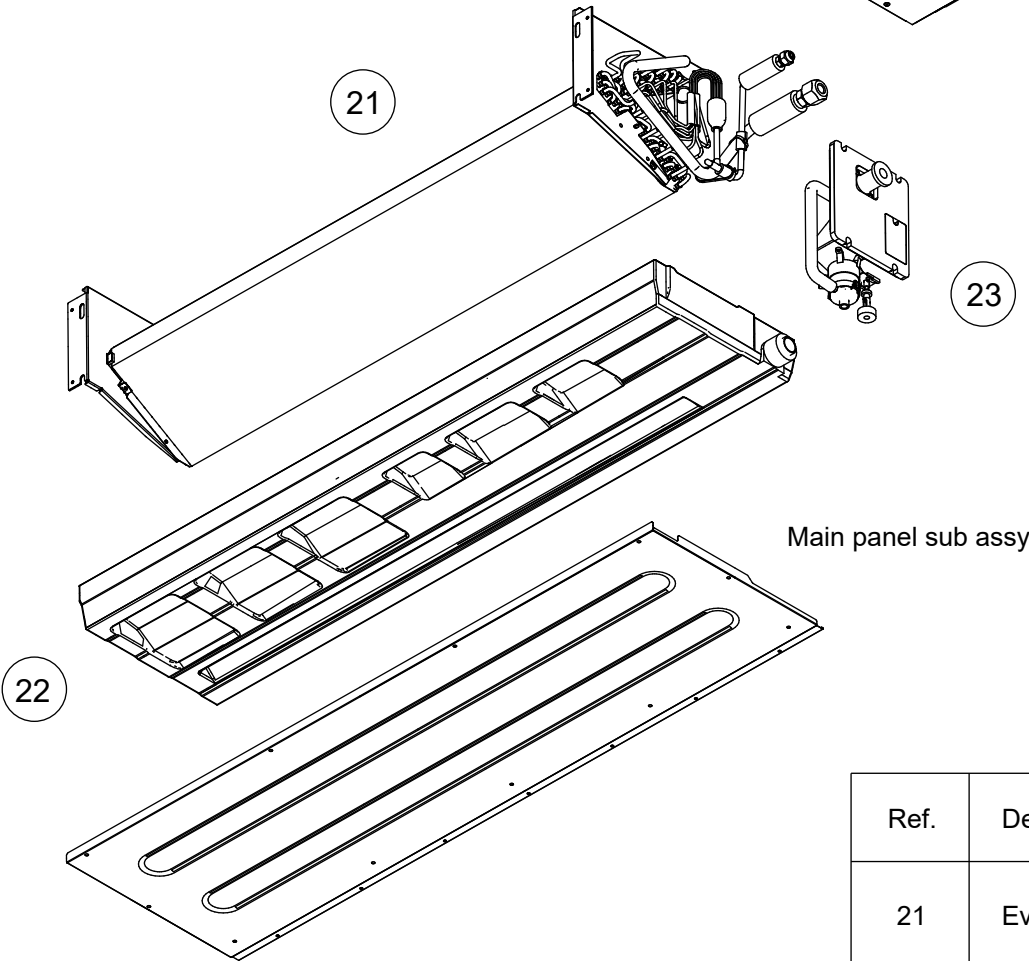

Main panel sub assy

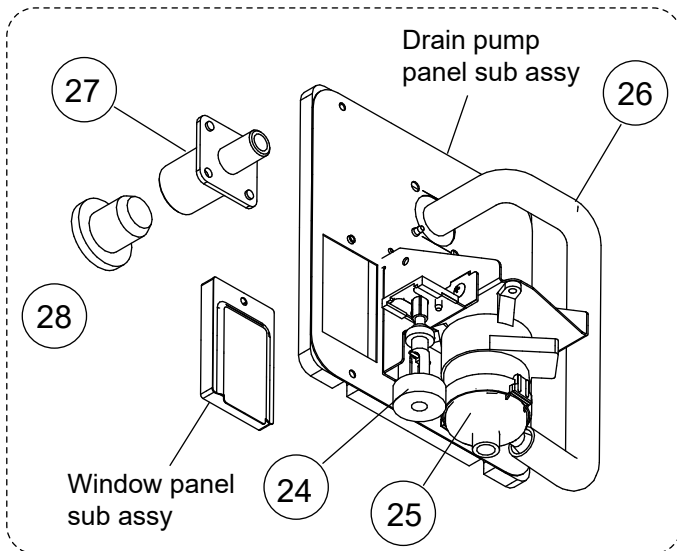

Ref.	Description	Part number
21	Evaporator total assy	9379349000
22	Drain Pan Sub Assy	9381752003
23	Drain Pump Sub Assy	9381766017
24	Float Switch	9900465070
25	Pump Assy	9900890018
26	Drain Hose	9381576005
27	Drain Port	9381565009
28	Drain Cap	9381578009

INDOOR UNIT  
 ARXG36KHTAP  
 ARXG45KHTAP  
 ARXG54KHTAP

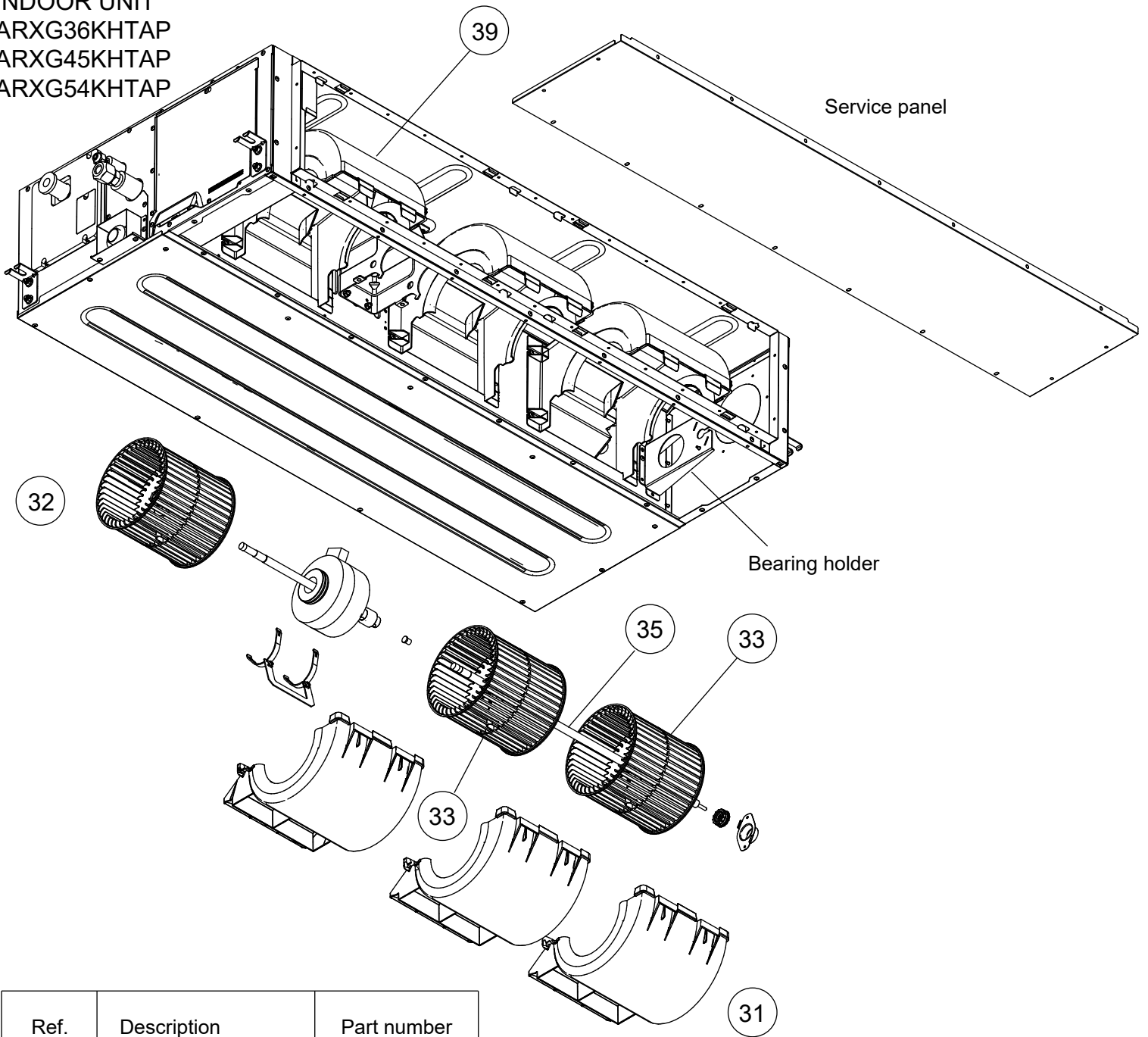

Ref.	Description	Part number
31	Casing B Sub Assy	9381829002
32	Sirocco Fan Assy	9381302000
33	Sirocco Fan Assy	9381302017
34	Bearing B Assy	9357921006
35	Shaft Assy	9381052028
36	Shaft Cap	9381814015
37	Joint Assy	9378038035
38	Fan motor	9603480011
39	Casing A	9381587001

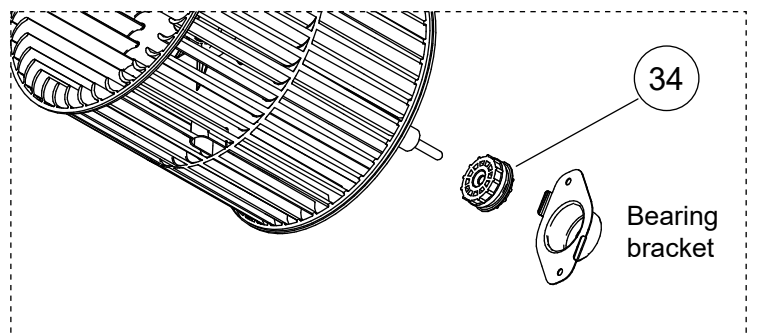
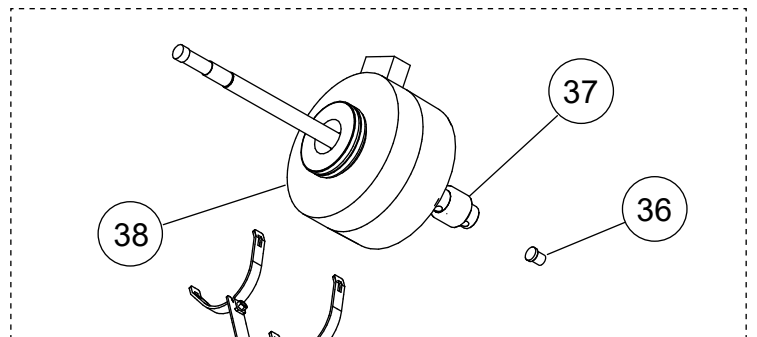

INDOOR UNIT  
ARXG36KHTAP  
ARXG45KHTAP  
ARXG54KHTAP

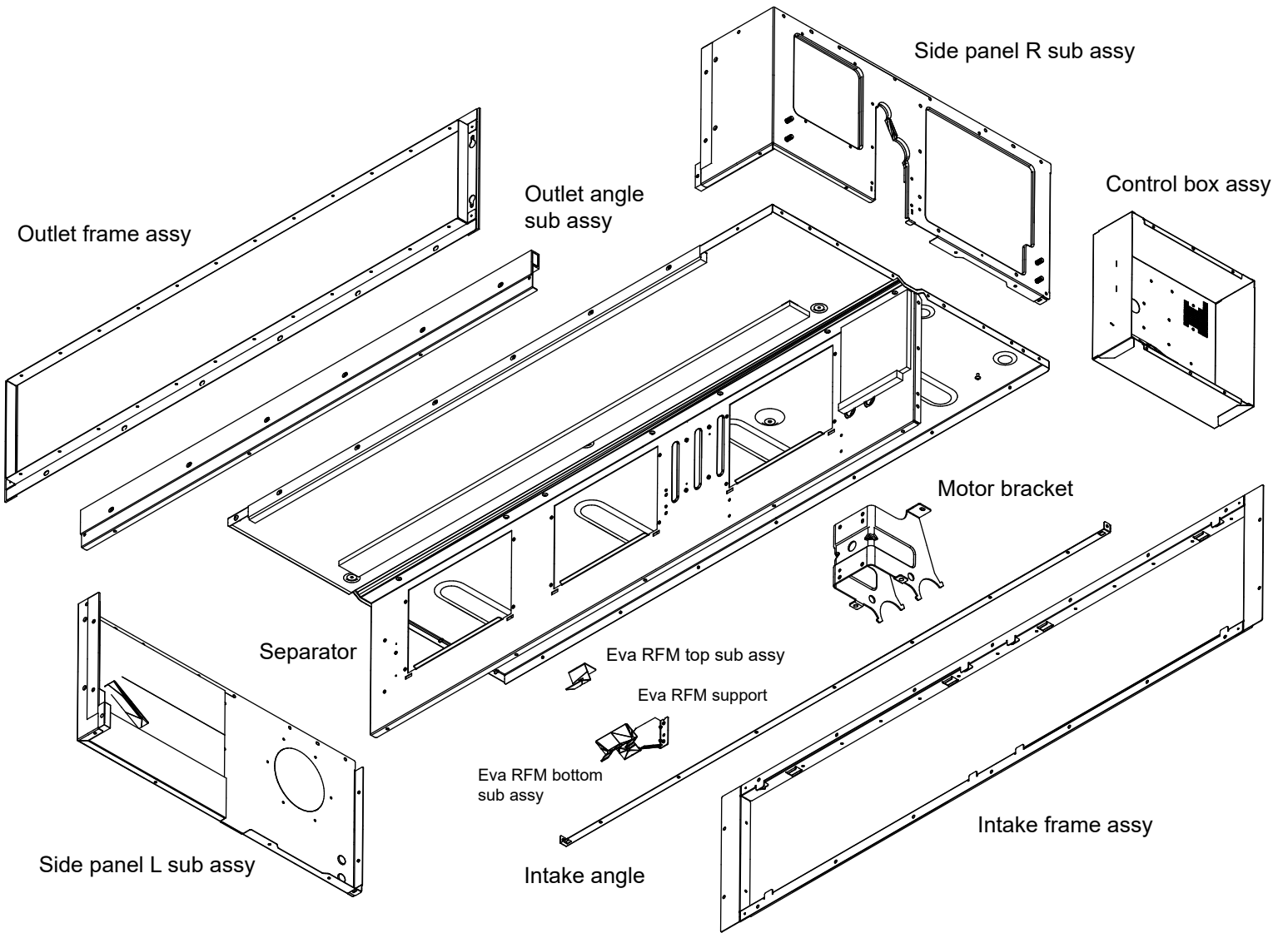



OUTDOOR UNIT  
AOYG24KBTB

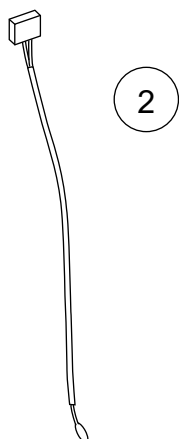
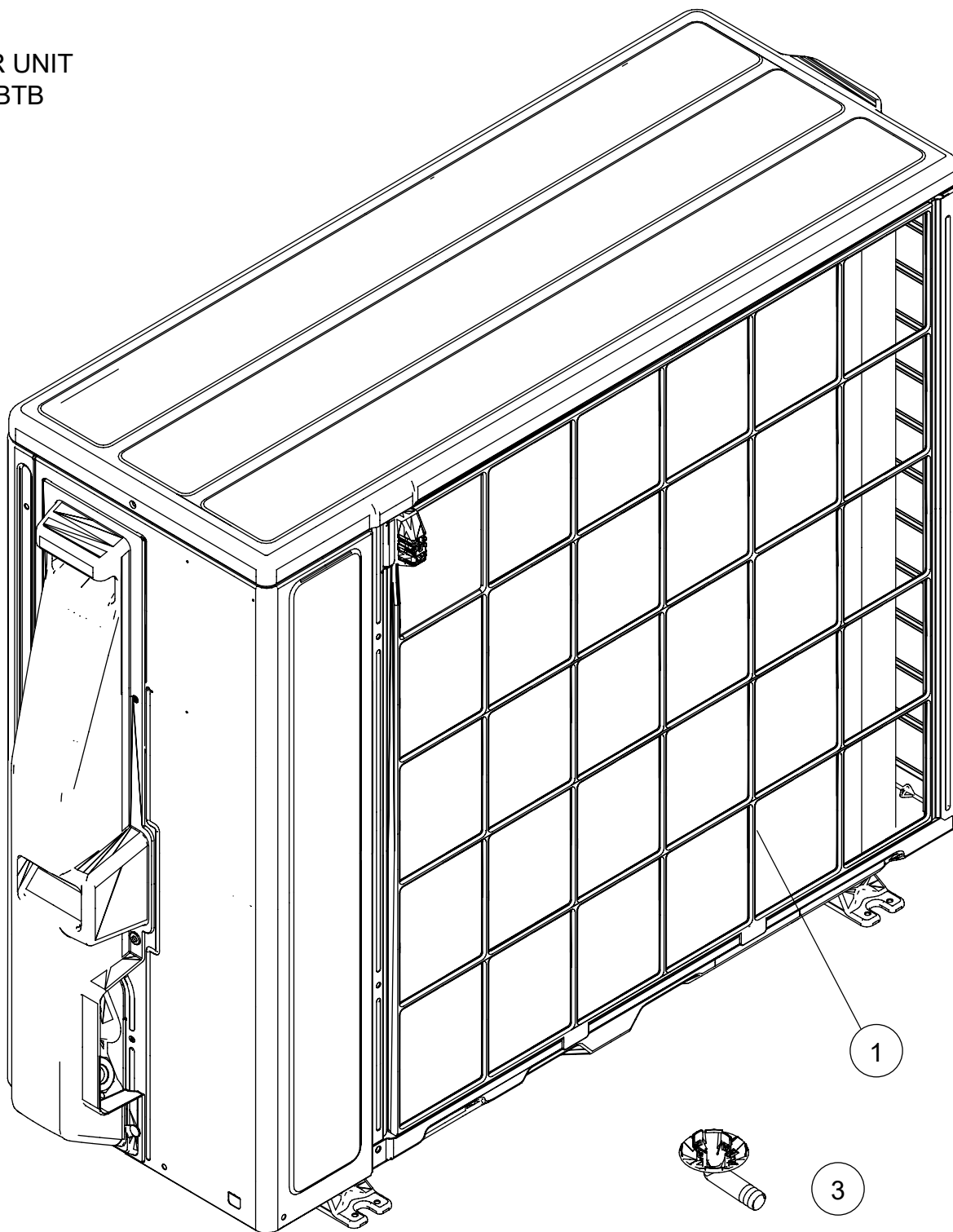

Ref.	Description	Part number
1	Protective net assy	9322811042
2	Outdoor thermistor	9900585060
3	Drain pipe	9322144003

OUTDOOR UNIT  
AOYG24KBTB

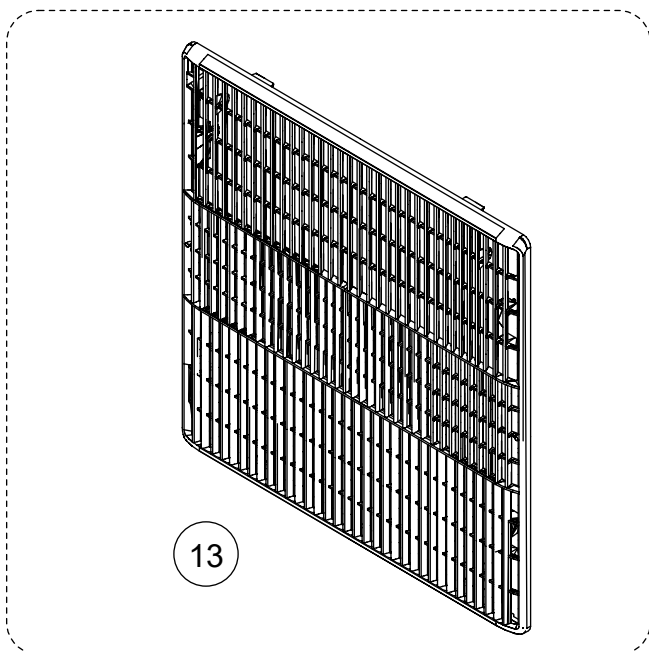
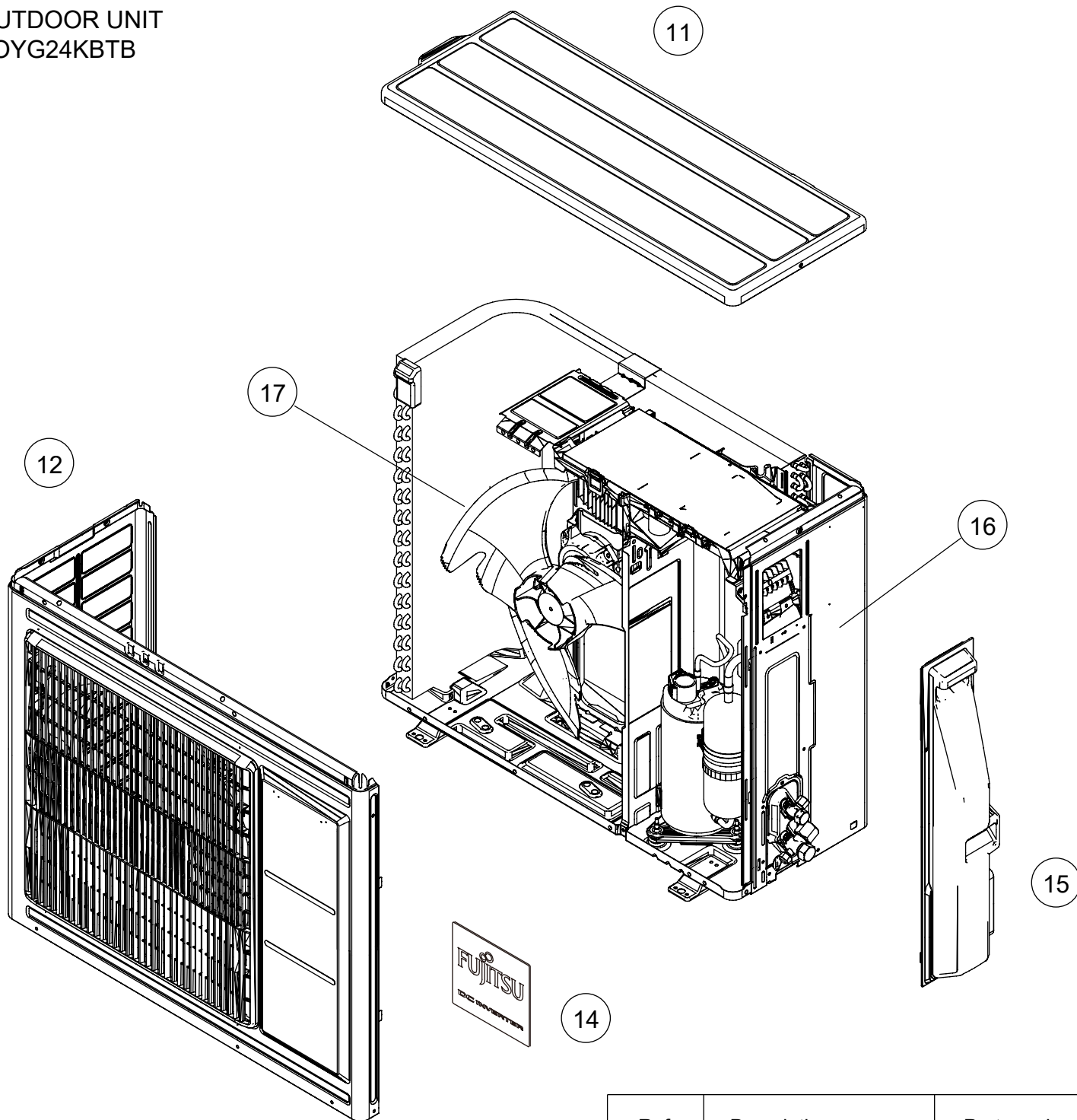

Ref.	Description	Part number
11	Top panel assy	9322556073
12	Front panel assy	9322555038
13	Blow grille	9322149008
14	Emblem	9319151007
15	Switch cover assy	9322570031
16	Cabinet right Assy	9322552150
17	Propeller fan	9322150004

OUTDOOR UNIT  
AOYG24KBTB

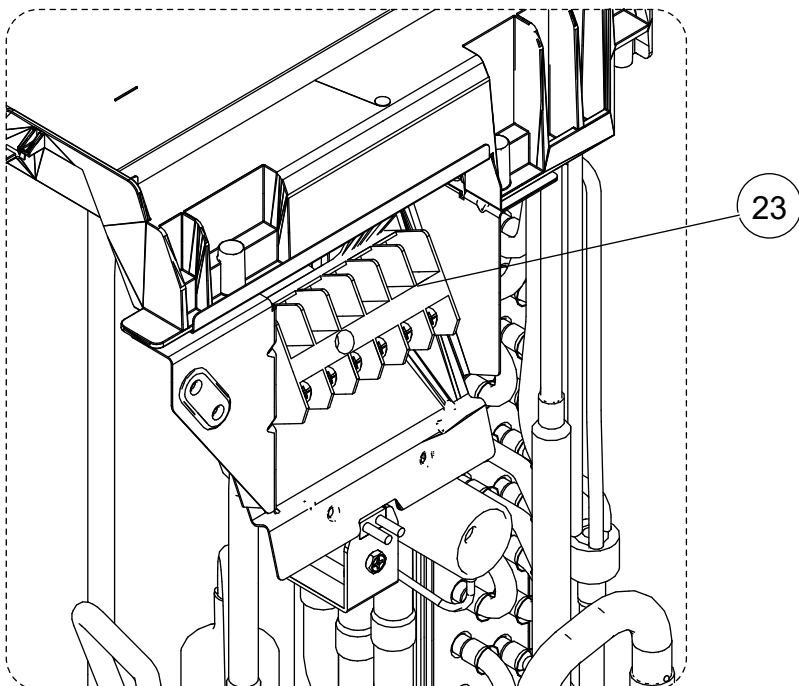
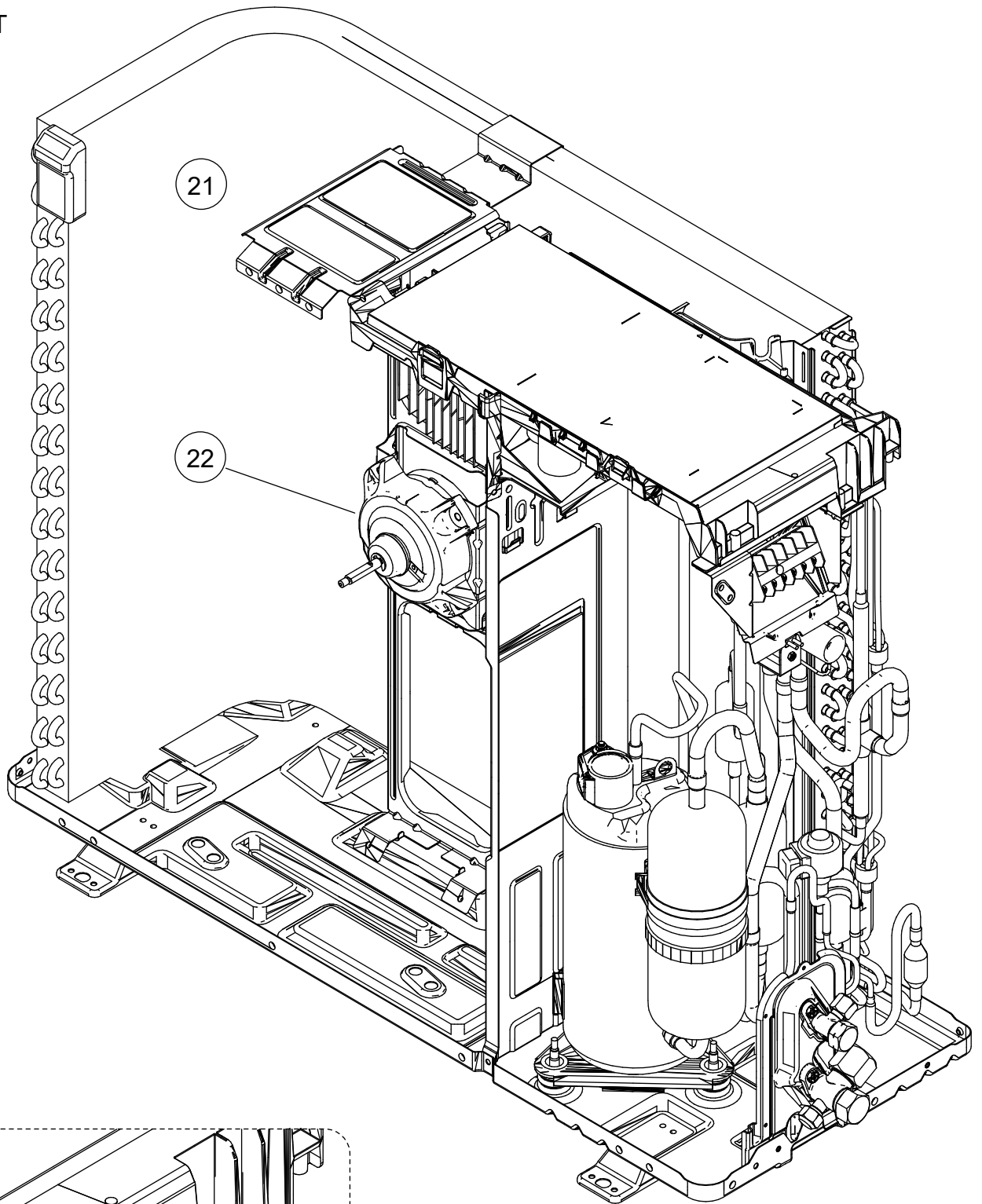

Ref.	Description	Part number
21	Motor bracket assy	9322553034
22	Brushless motor	9603601003
23	Terminal	9900435028

OUTDOOR UNIT  
AOYG24KBTB

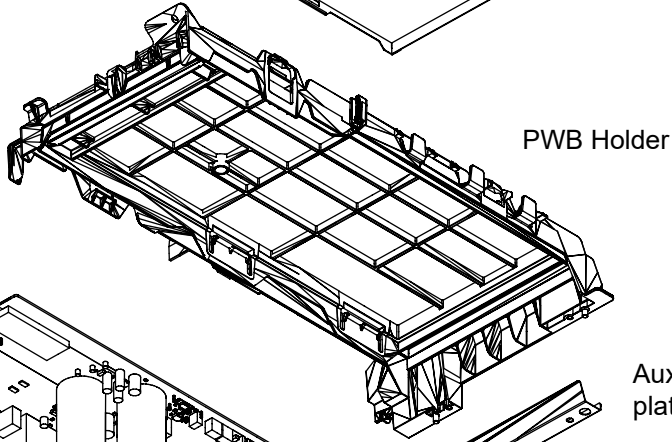
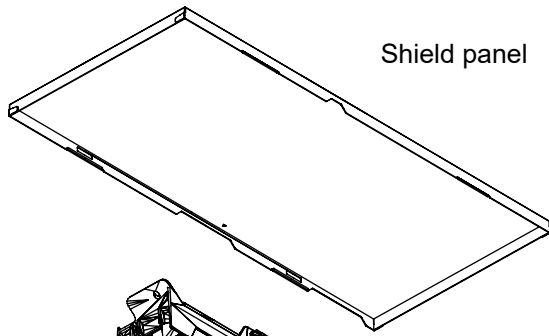

31

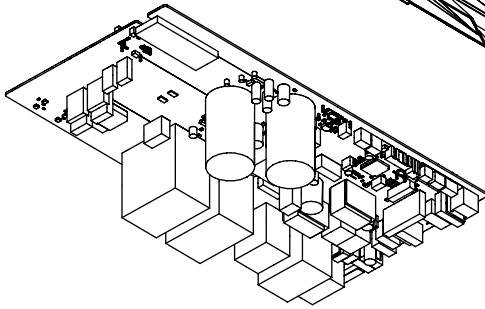

Auxiliary plate

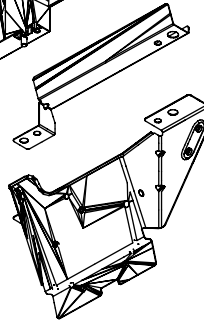

Terminal bracket assy

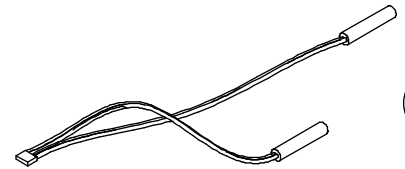
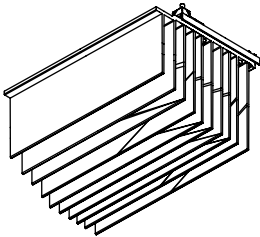

33

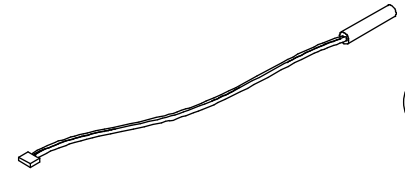

34

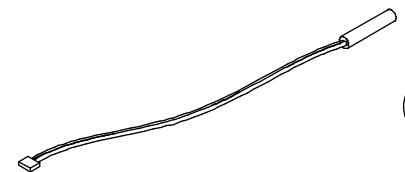

35

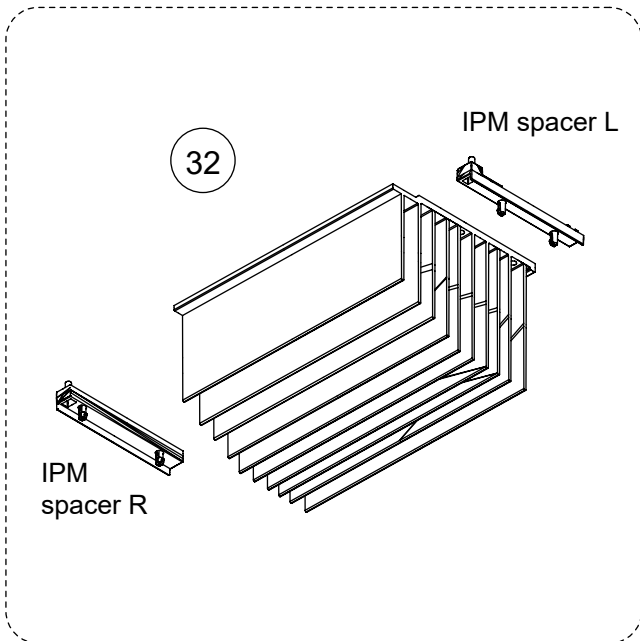
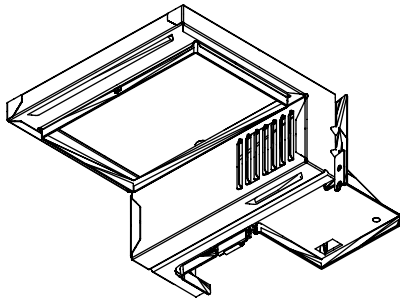

Ref.	Description	Part number
31	Main PCB, Service unit	9709683408
32	Heatsink	9322421043
33	Thermistor assy	9900727116
34	Heat exchanger thermistor	9900984014
35	Compressor thermistor	9900985011

OUTDOOR UNIT  
AOYG24KBTB

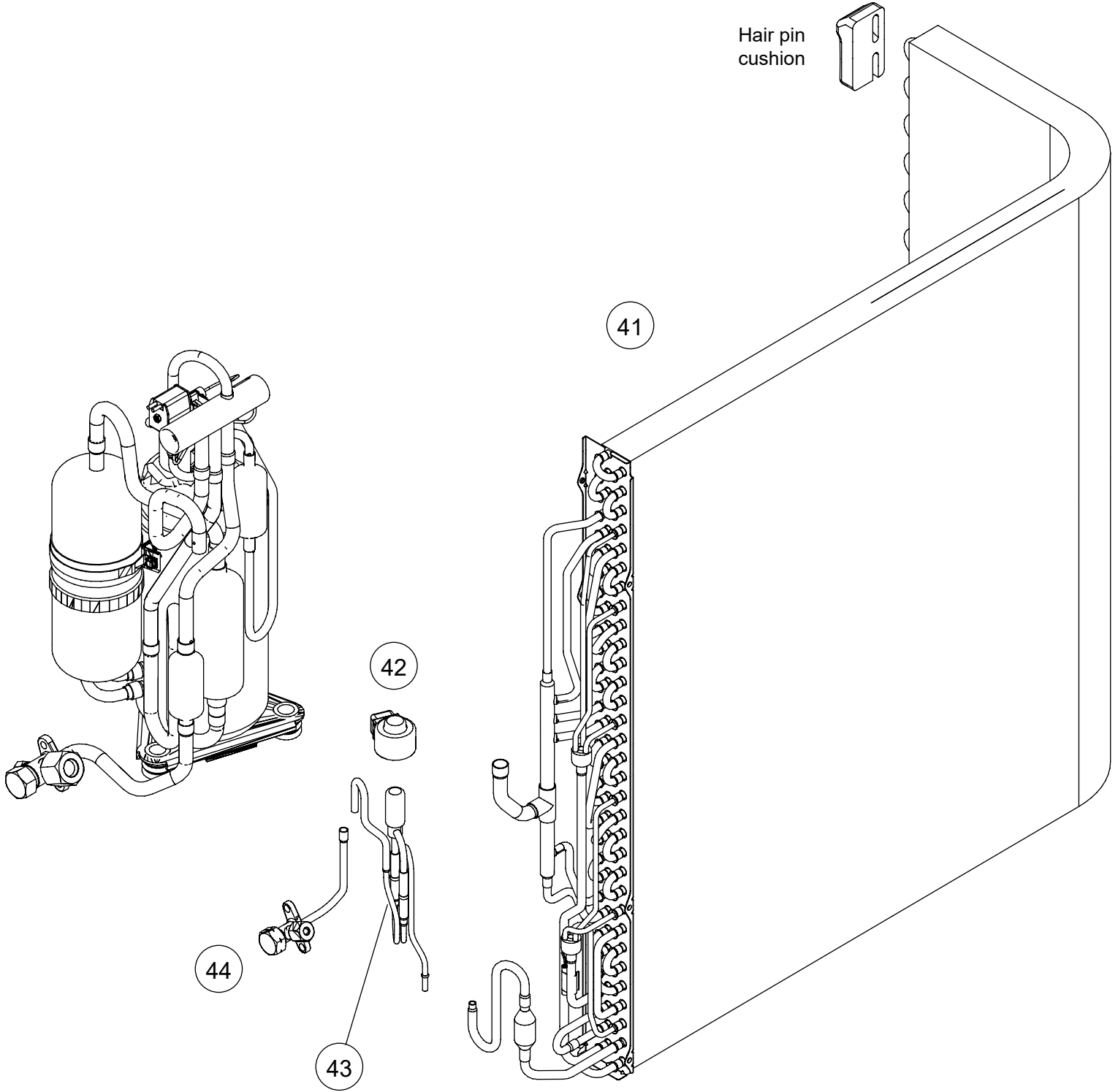

Ref.	Description	Part number
41	Condenser total assy	9317089630
42	Expansion valve coil	9970173028
43	Pulse motor valve assy	9322463029
44	2-way valve assy	9322474001

OUTDOOR UNIT  
AOYG24KBTB

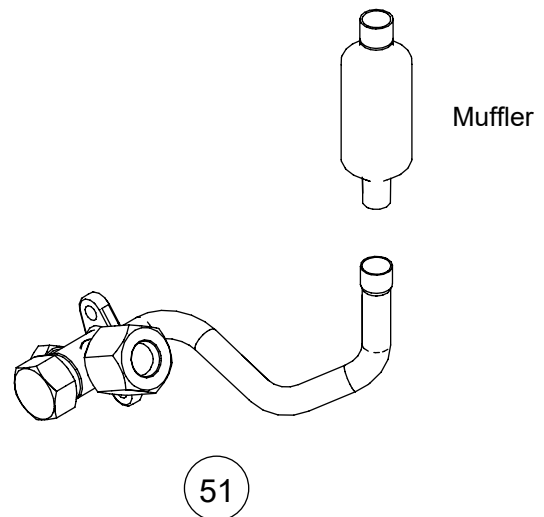
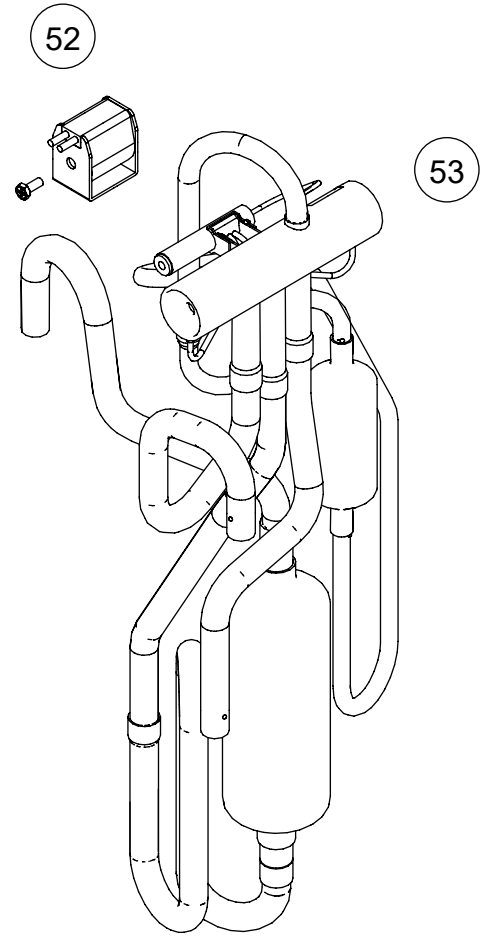
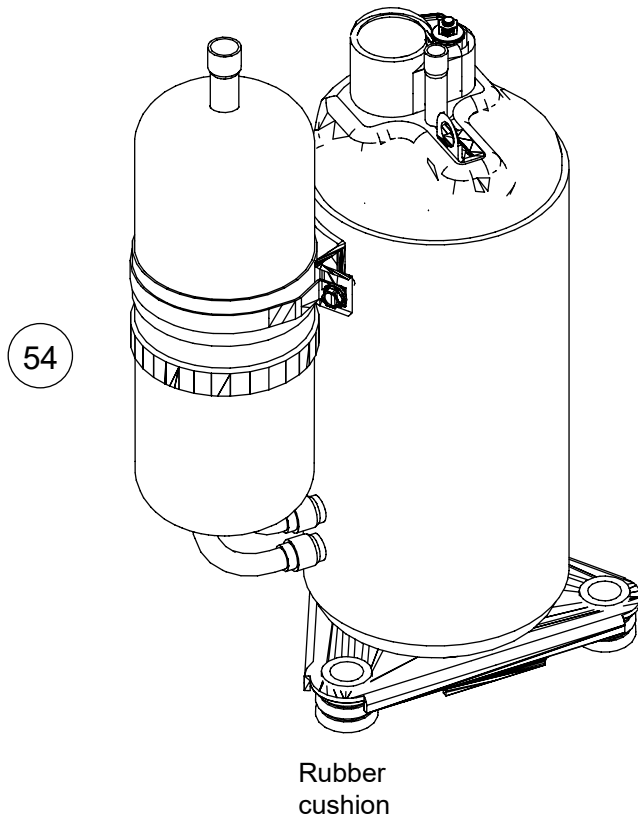

Ref.	Description	Part number
51	3-way valve assy	9387831016
52	Solenoid	9970206009
53	4-way valve assy	9383129025
54	Compressor	9810521002
-	S-insulator B	9322503008
-	S-insulator F	9322529008
-	S-insulator H	9322501004
-	S-insulator V	9323045002
-	S-insulator K	9322824004

OUTDOOR UNIT  
AOYG30KBTB  
AOYG36KBTB

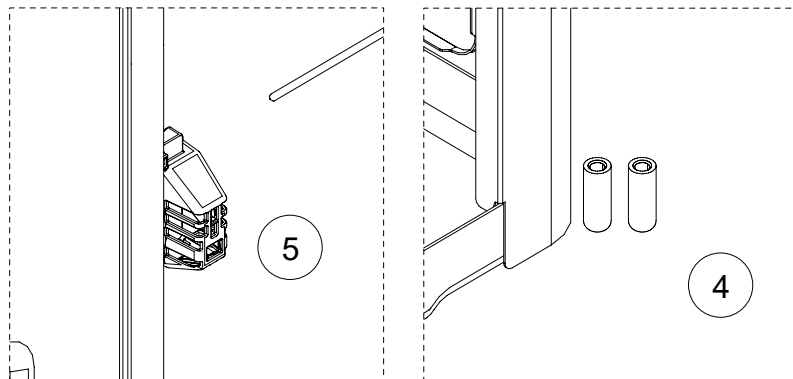
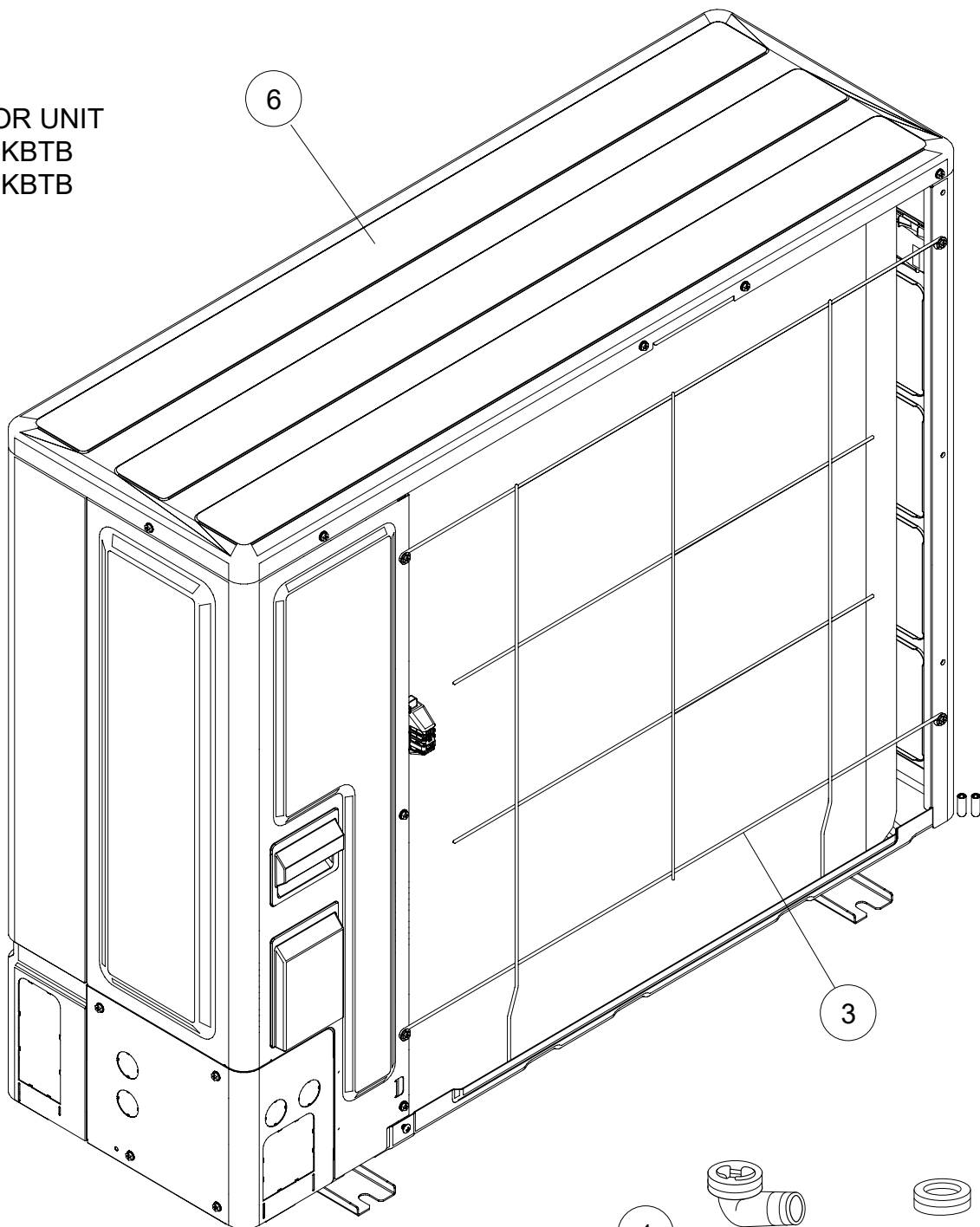

Ref.	Description	Parts number
1	Drain assy	9303029015
2	Drain cap	313166024302
3	Protective net rear	9383779008
4	Rubber (net)	9375361013
5	Thermo holder	9383607004
6	Top panel sub assy	9383880001
13	Outdoor Thermistor	9900565091

OUTDOOR UNIT  
 AOYG30KBTB  
 AOYG36KBTB

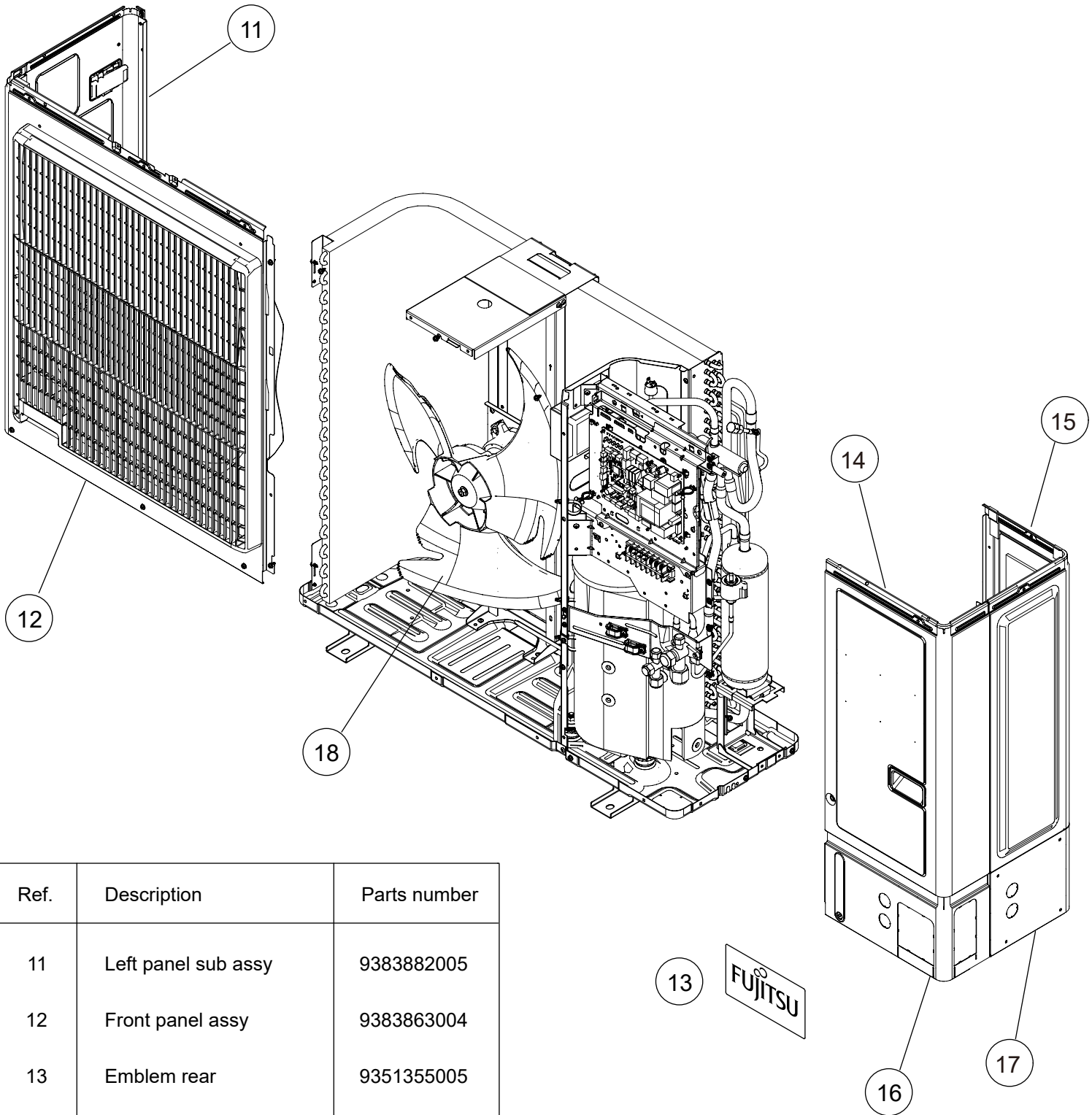

Ref.	Description	Parts number
11	Left panel sub assy	9383882005
12	Front panel assy	9383863004
13	Emblem rear	9351355005
14	Sevice panel sub assy	9383876004
15	Right panel sub assy	9383874000
16	Pipe cover front	9383878008
17	Pipe cover rear	9383879005
18	Propeller fan	9383336003



OUTDOOR UNIT  
 AOYG30KBTB  
 AOYG36KBTB

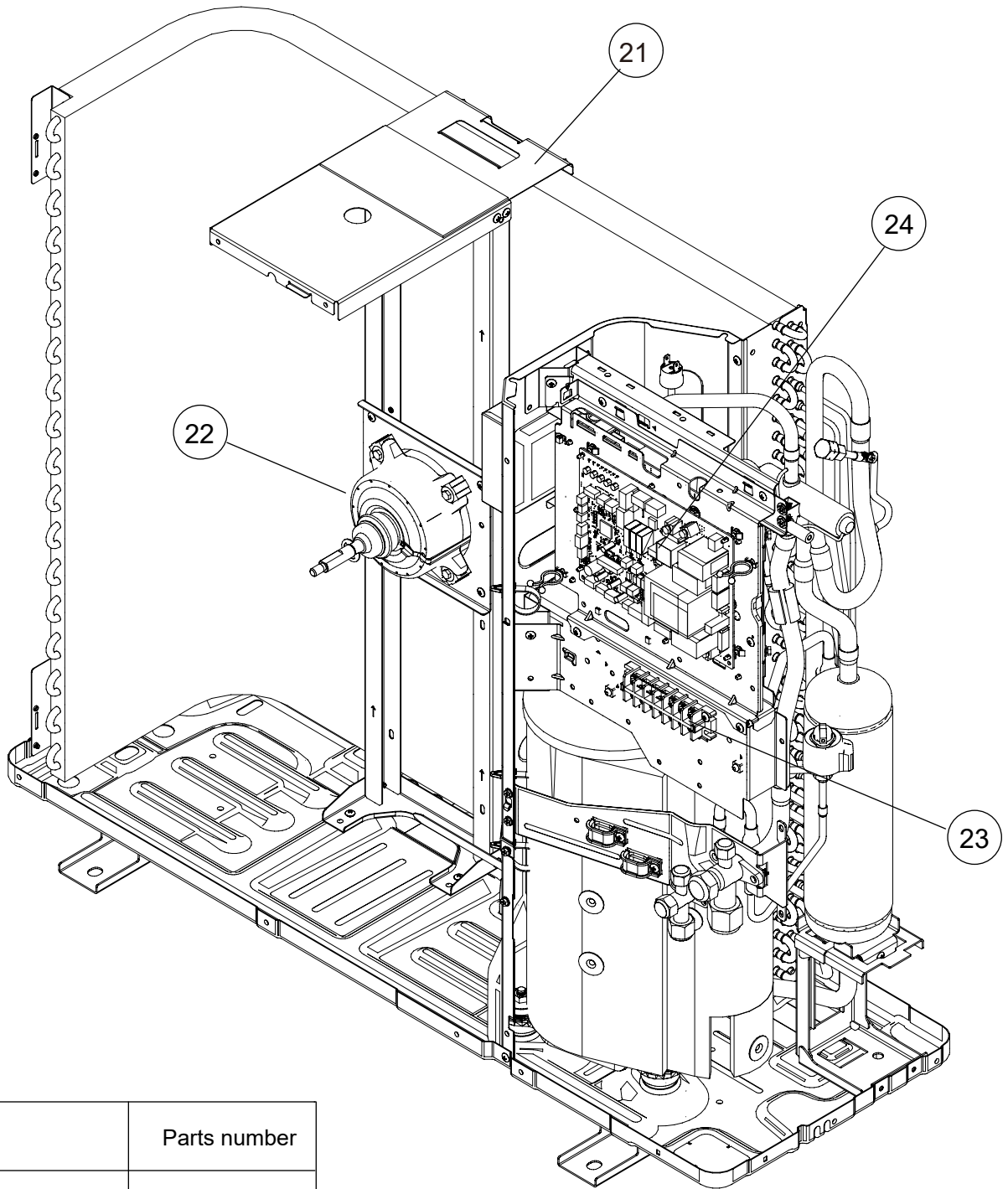

Ref.	Description	Parts number
21	Motor bracket assy	9383862007
22	Motor, DC Brushless	9603732011
23	Terminal 7P	9900203061
24	Main PCB (Service) (30)	9711431004
24	Main PCB (Service) (36)	9711431011
25	Inverter PCB	9711233004
--	Heat ex. thermistor	9900984038
--	Thermistor assy	9900727154
--	Compressor thermistor	9900985035

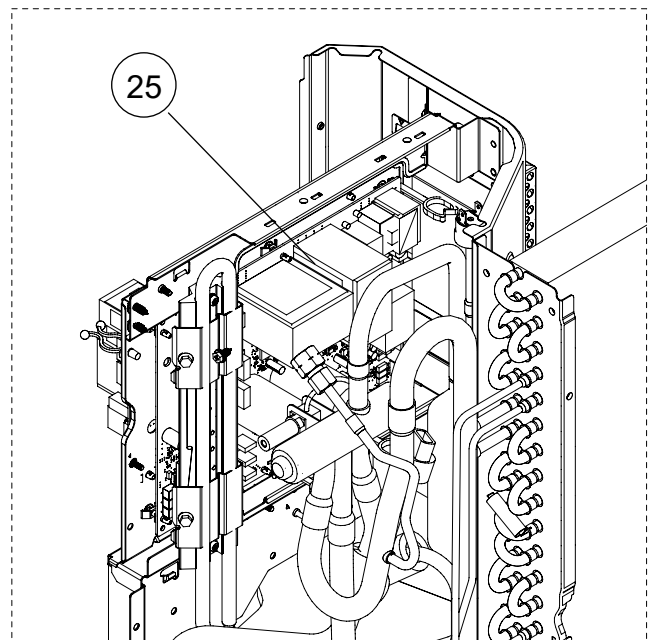

OUTDOOR UNIT  
 AOYG30KBTB  
 AOYG36KBTB

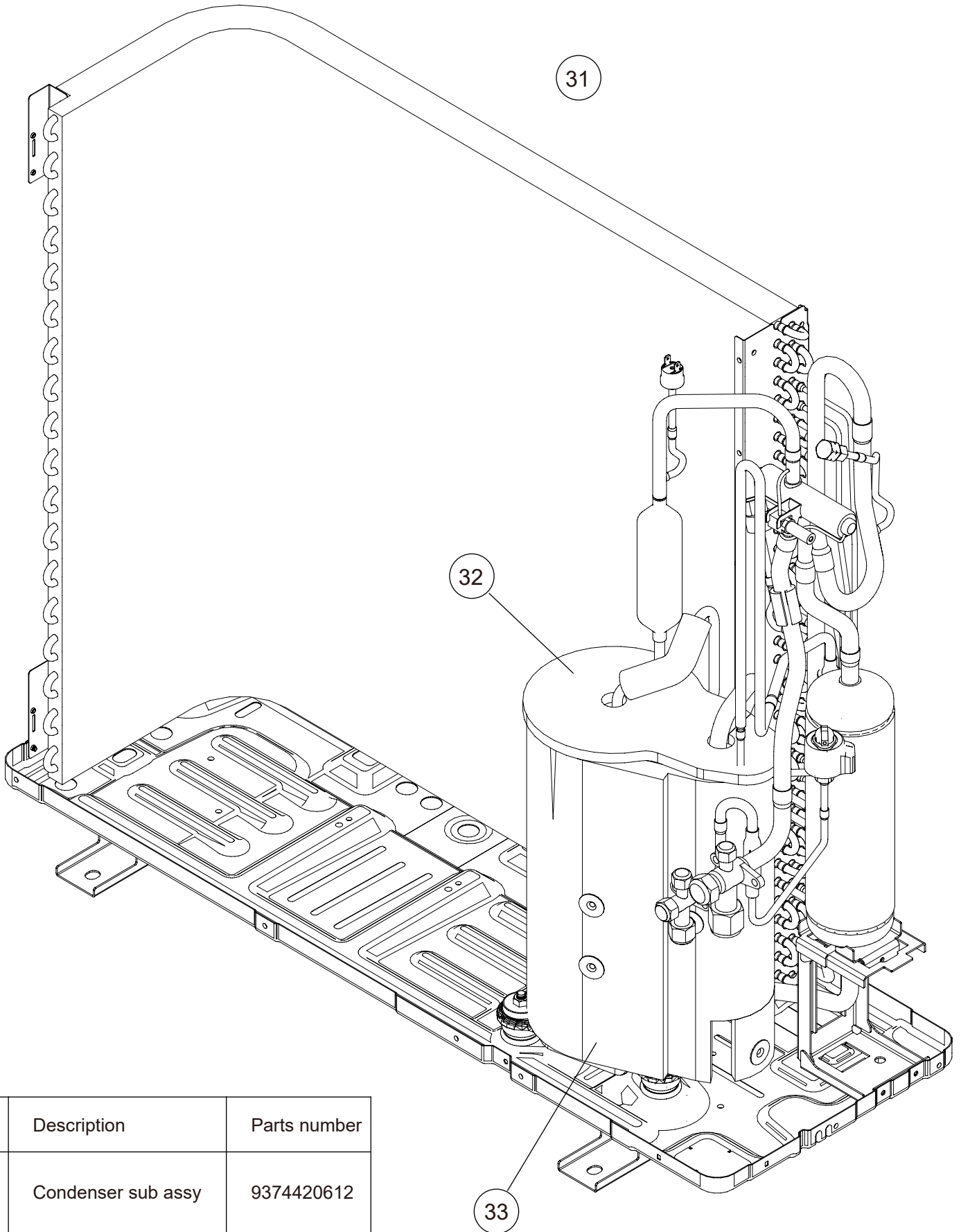

Ref.	Description	Parts number
31	Condenser sub assy	9374420612
32	S-ABS (top)	9380516064
33	S-ABS (body)	9379647168

OUTDOOR UNIT  
 AOYG30KBTB  
 AOYG36KBTB

Ref.	Description	Parts number
41	Compressor assy	9383821004
42	Accumulator assy	9375250140
43	Solenoid	9970194016
44	4-way valve assy (30)	9374425648
44	4-way valve assy (36)	9374425631
45	pressure switch	9900186029
46	Sensor (36)	9970158018
47	Expansion valve coil	9970209000
48	Expansion valve assy	9370947328
49	3-way valve assy	9377958037
50	3-way valve assy	9379079013

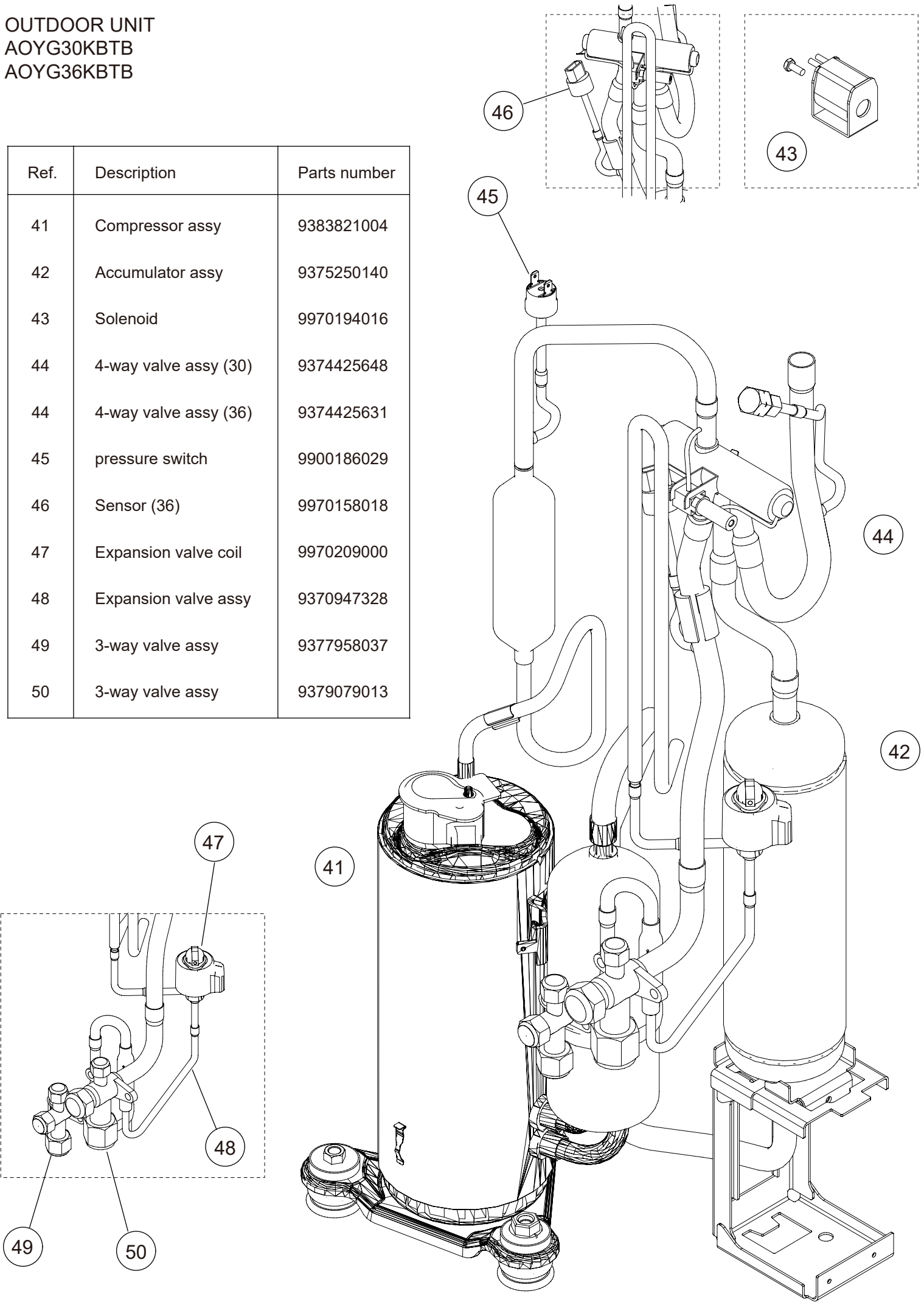

OUTDOOR UNIT  
AOYG45KBTB  
AOYG54KBTB

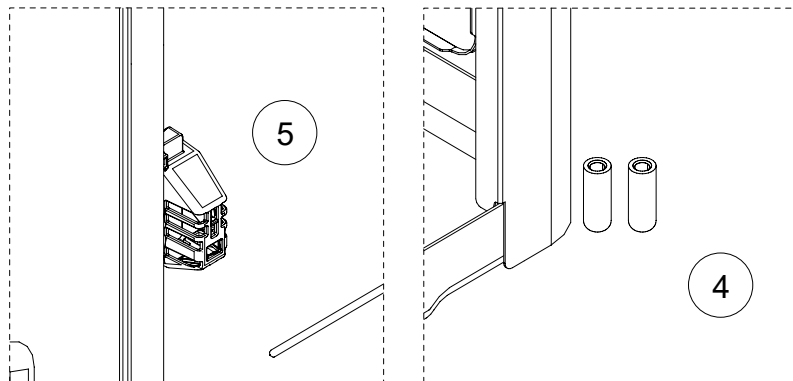
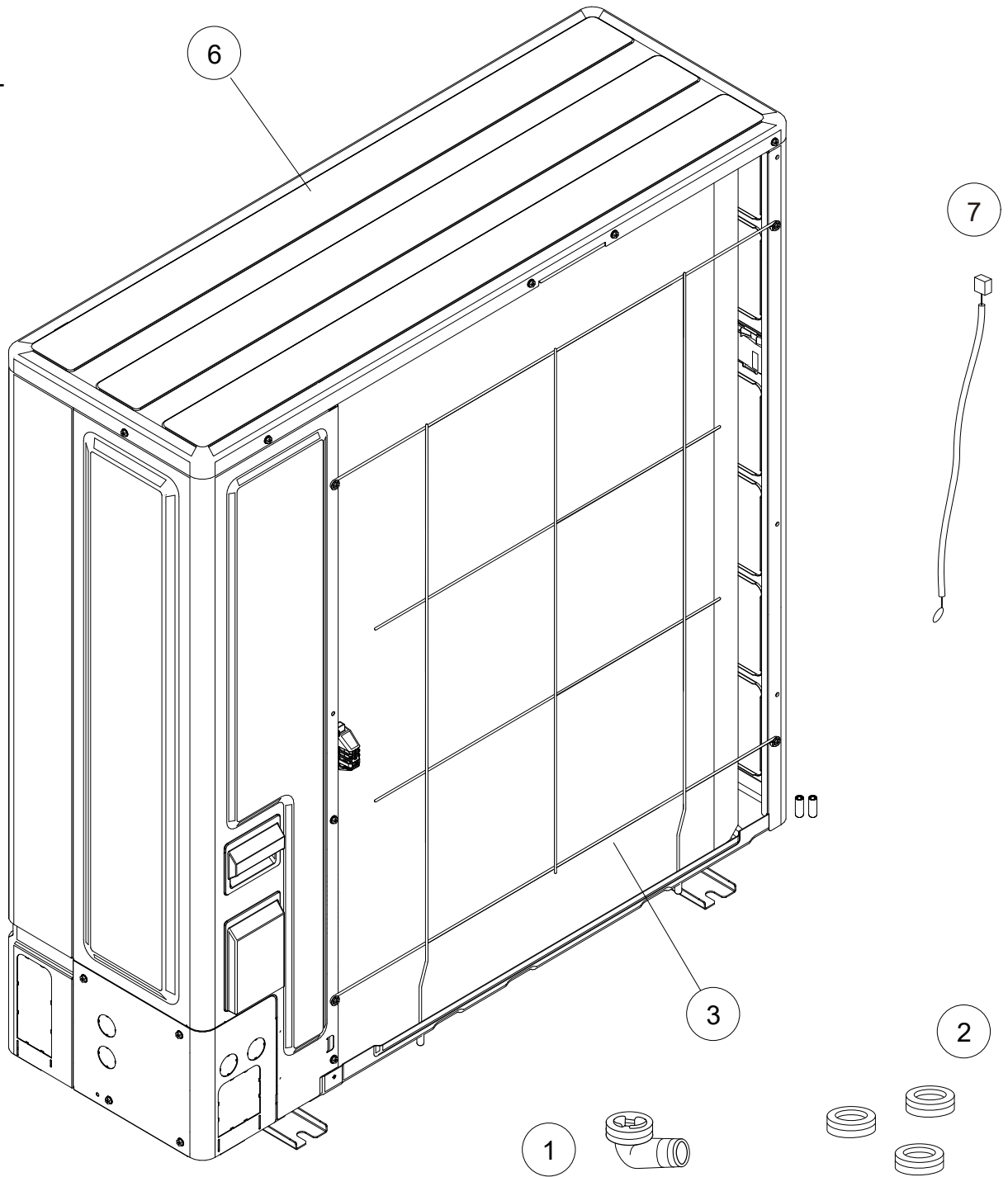

Ref.	Description	Parts number
1	Drain assy	9303029015
2	Drain cap	313166024302
3	Protective net rear	9381013005
4	Rubber (net)	9375361013
5	Thermo holder	9383607004
6	Top panel sub assy	9383880001
7	Outdoor Thermistor	9900565091

OUTDOOR UNIT  
 AOYG45KBTB  
 AOYG54KBTB

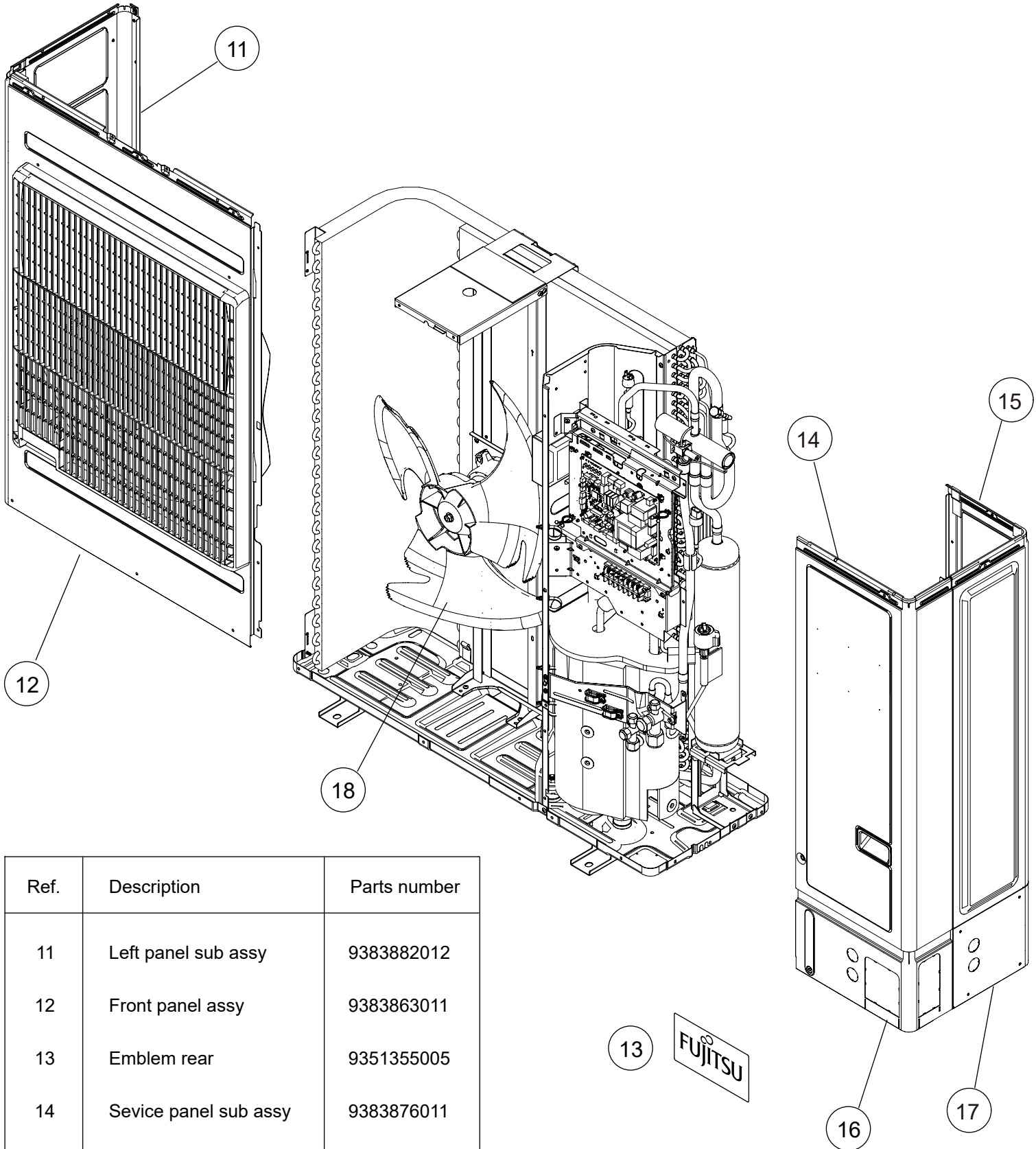

Ref.	Description	Parts number
11	Left panel sub assy	9383882012
12	Front panel assy	9383863011
13	Emblem rear	9351355005
14	Sevice panel sub assy	9383876011
15	Right panel sub assy	9383874017
16	Pipe cover front	9383878008
17	Pipe cover rear	9383879005
18	Propeller fan	9383336003

OUTDOOR UNIT  
 AOYG45KBTB  
 AOYG54KBTB

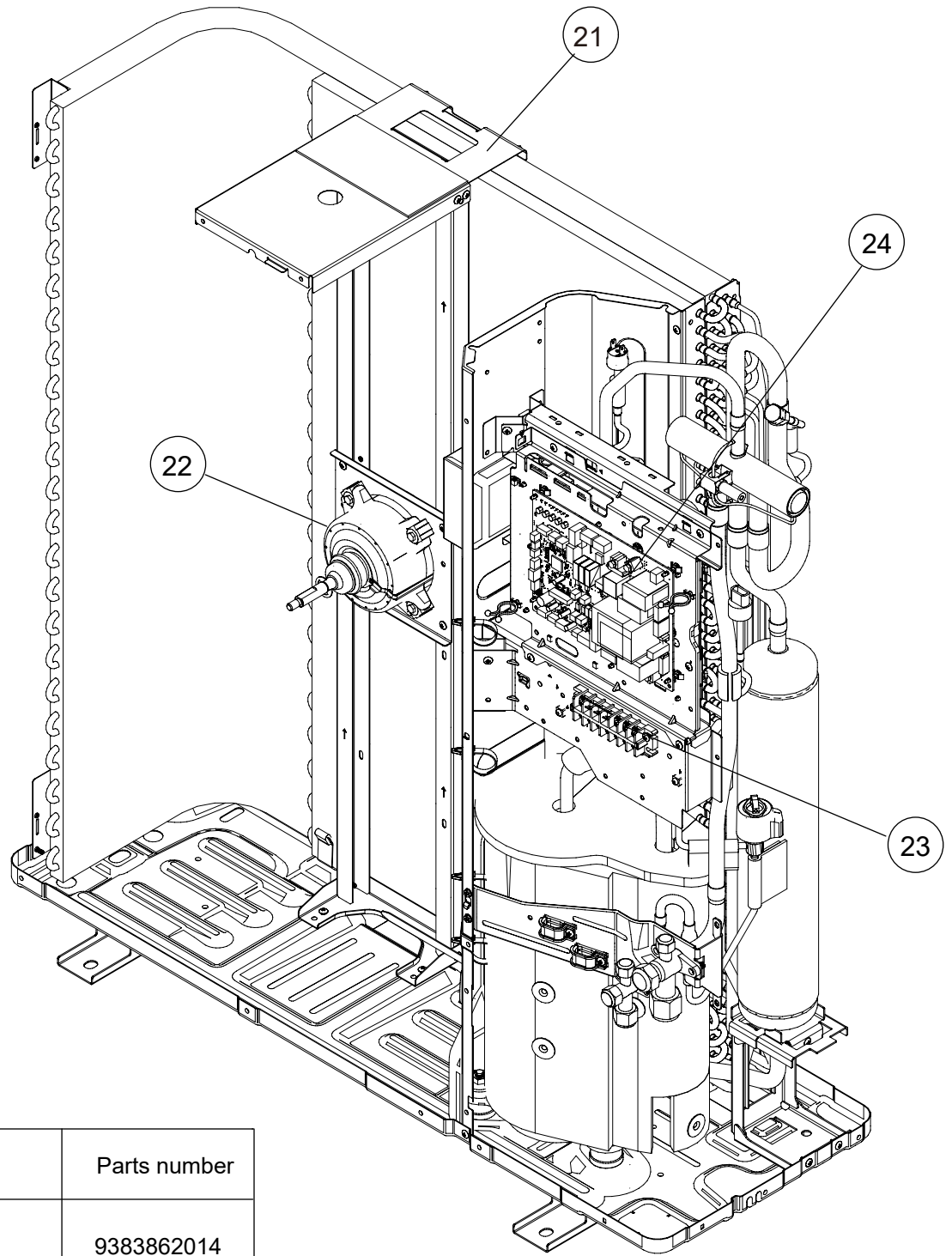

Ref.	Description	Parts number
21	Motor bracket assy	9383862014
22	Motor, DC Brushless	9603733018
23	Terminal 7P	9900203061
24	Main PCB (Service) (45)	9711431028
24	Main PCB (Service) (54)	9711431035
25	Inverter PCB	9711233011
--	Heat ex. thermistor	9900984038
--	Thermistor assy	9900727154
--	Compressor thermistor	9900985028

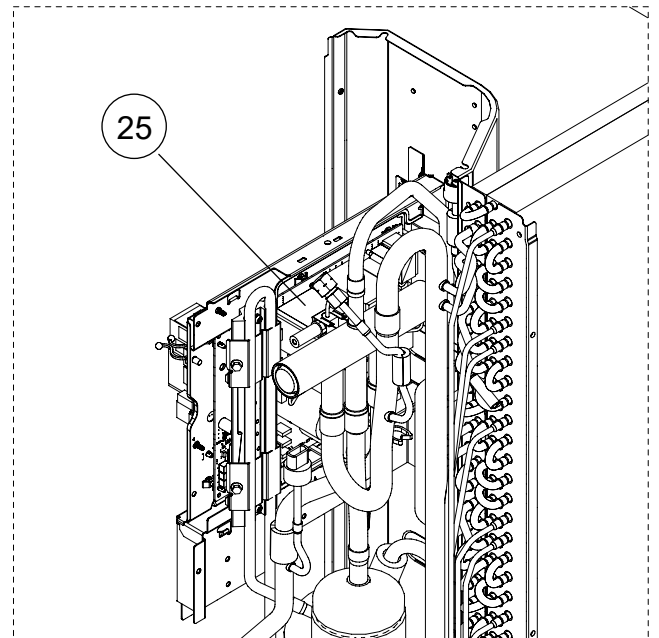

OUTDOOR UNIT  
 AOYG45KBTB  
 AOYG54KBTB

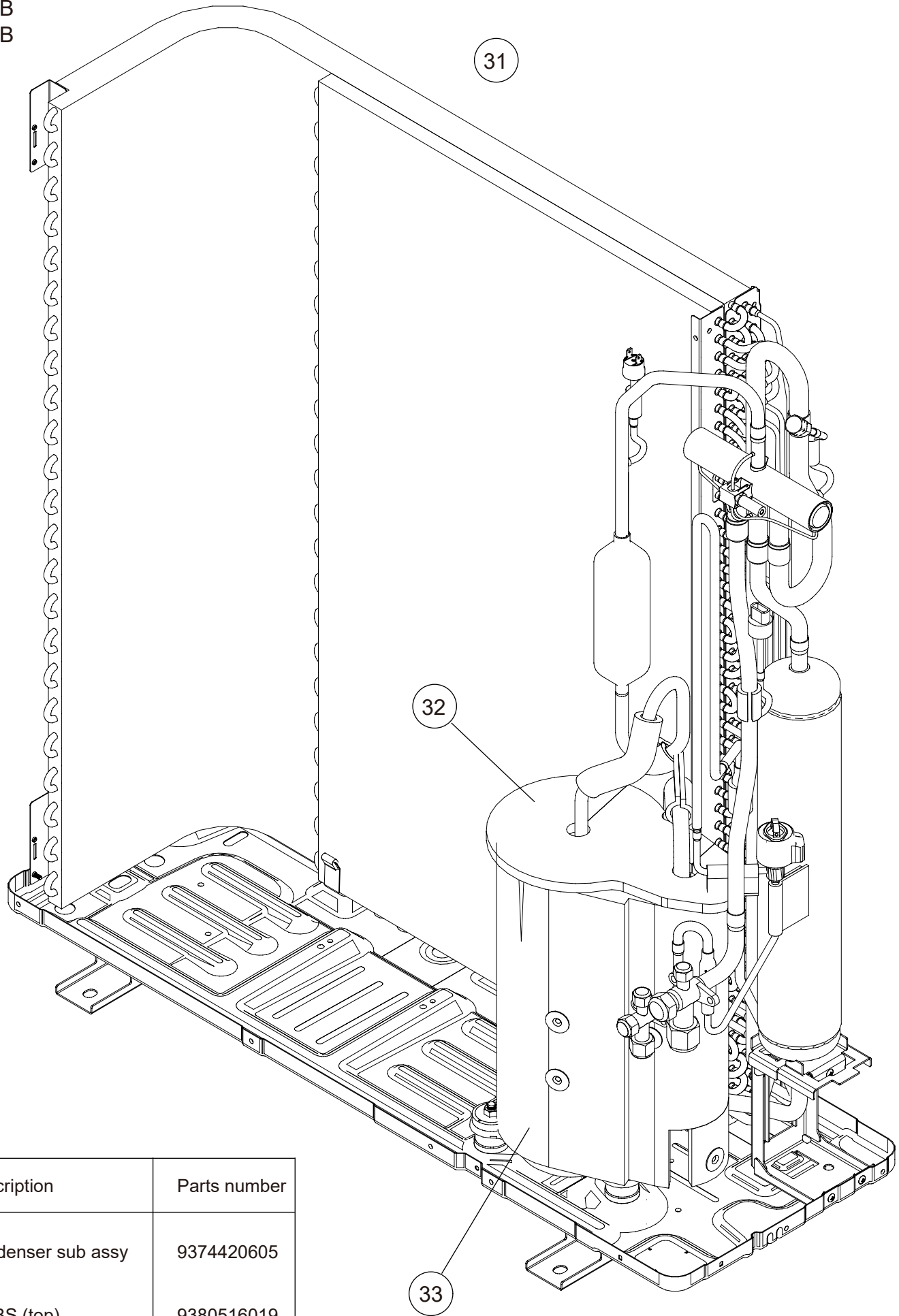

Ref.	Description	Parts number
31	Condenser sub assy	9374420605
32	S-ABS (top)	9380516019
33	S-ABS (body)	9379647168

OUTDOOR UNIT  
 AOYG45KBTB  
 AOYG54KBTB



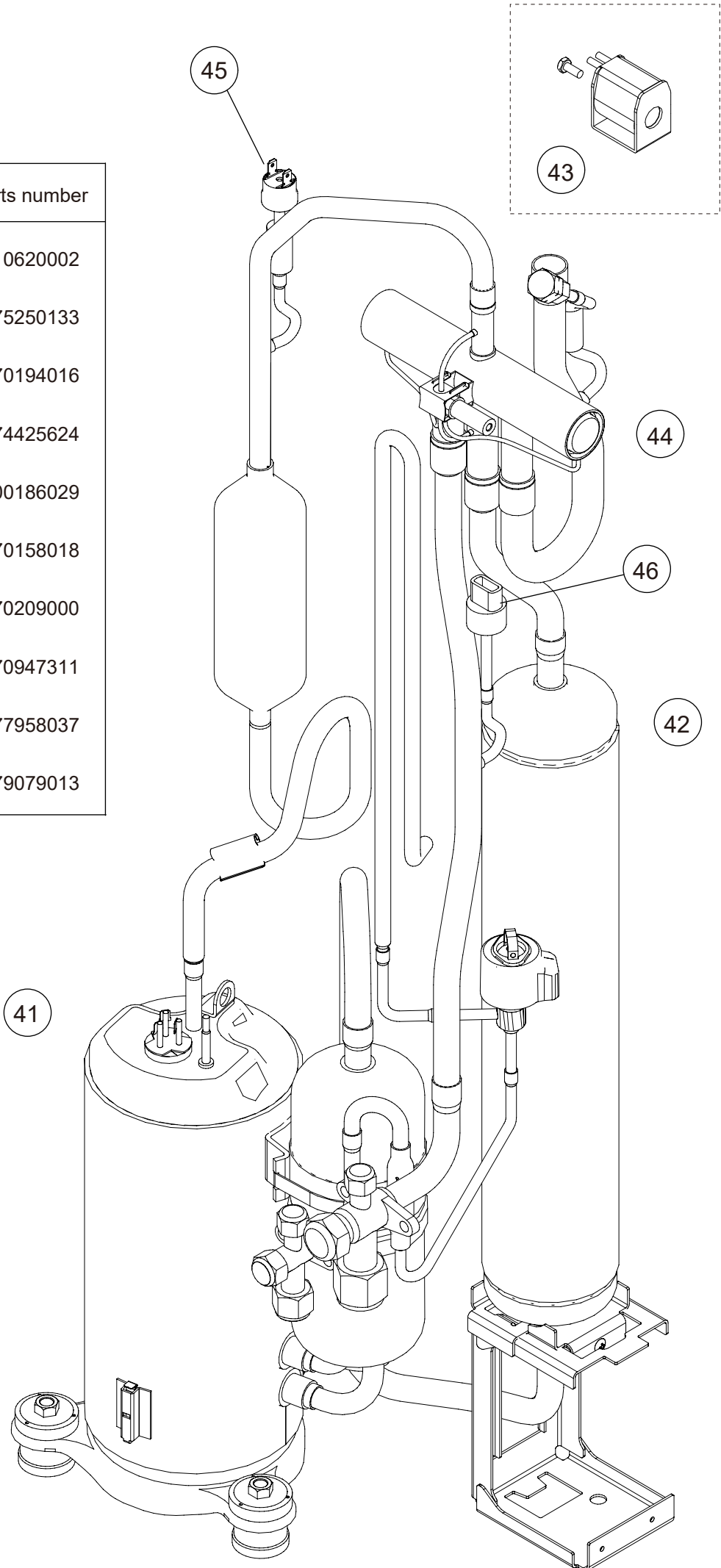
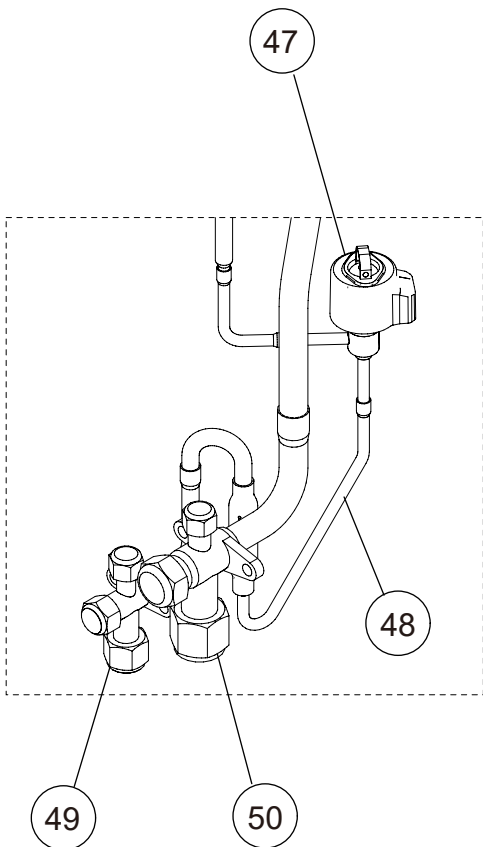





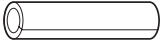
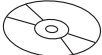
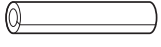

Ref.	Description	Parts number
41	Compressor	9810620002
42	Accumulator assy	9375250133
43	Solenoid	9970194016
44	4-way valve assy	9374425624
45	pressure switch	9900186029
46	Sensor	9970158018
47	Expansion valve coil	9970209000
48	Expansion valve assy	9370947311
49	3-way valve assy	9377958037
50	3-way valve assy	9379079013







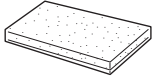

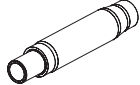
## Accessories ( Indoor unit )

**Models: ARXG24KHTAP, ARXG30KHTAP, ARXG36KHTAP, ARXG45KHTAP, and ARXG54KHTAP**

Part name	Exterior	Q'ty	Part name	Exterior	Q'ty
Operating manual		1	Coupler heat insulation (large)		1
Operating manual (CD-ROM)		1	Coupler heat insulation (small)		1
Installation manual		1	Cable tie (large)		4
M10 nut A (with flange)		4	Cable tie (medium)		1
M10 nut B (with spring lock washer)		4	Cable tie (small)		1
Washer		8	Drain hose insulation		1
Hose band		1	Drain hose		1

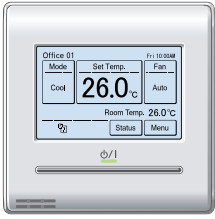
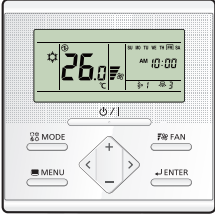
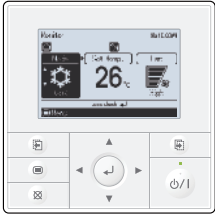
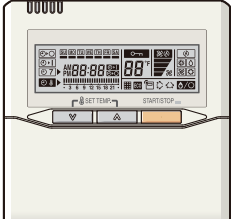
# Optional parts

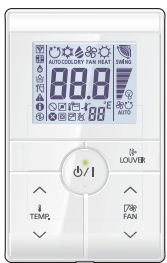
## 1. Controllers



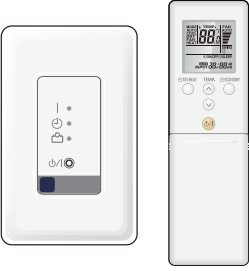

Exterior	Part name	Model name	Summary
	Wired remote controller	UTY-RNRYZ*	Easy finger touch operation with LCD panel. Backlit LCD enables easy operation in a dark room. Wire type: Non-polar 2-wire
	Wired remote controller	UTY-RLRY	High visibility and easy operation. Room temperature can be accurately controlled using the built-in thermo sensor. Wire type: Non-polar 2-wire
	Wired remote controller	UTY-RVNYM	Large and full-dot liquid crystal screen, wide and large keys easy to press, user-intuitive arrow key. Wire type: Polar 3-wire
	Wired remote controller	UTY-RNNYM	Room temperature can be controlled by detecting the temperature accurately with built-in thermo sensor. Wire type: Polar 3-wire
	Simple remote controller	UTY-RSRY	Compact remote controller concentrates on the basic functions such as Start/Stop, fan control, temperature setting, and operation mode. Wire type: Non-polar 2-wire
	Simple remote controller	UTY-RHRY	Compact remote controller concentrates on the basic functions such as Start/Stop, fan control, and temperature setting. Wire type: Non-polar 2-wire
	Simple remote controller	UTY-RSNYM	Compact remote controller concentrates on the basic functions such as Start/Stop, fan control, temperature setting, and operation mode. Wire type: Polar 3-wire

Exterior	Part name	Model name	Summary
	IR receiver kit with wireless remote controller	UTY-LBTYM	Unit control is performed by wireless remote controller.

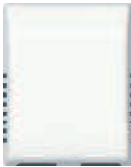
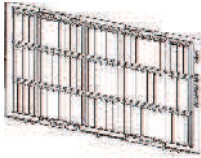
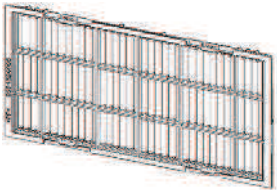
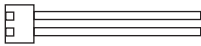
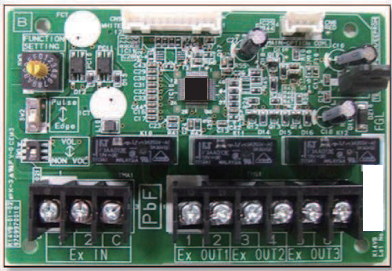
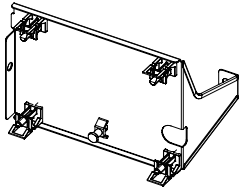
**NOTE:** Available functions may differ by the remote controller. For details, refer to the operation manual.



## 2. Others

Exterior	Part name	Model name	Summary
	Remote sensor unit	UTY-XSZX	Thermo-sensor for sensing the temperature of arbitrary place in the room.
	Long-life filter	UTD-LFNB	Long-life filter can be mounted to the indoor unit. (For 24 and 30 models)
	Long-life filter	UTD-LFNA	Long-life filter can be mounted to the indoor unit. (For 36, 45, and 54 models)
	External connect kit	UTY-XWZXZG	Use to connect with various peripheral devices and air conditioner PCB. For control output port.
	External input and output PCB	UTY-XCSX	Use to connect with external devices and air conditioner PCB.
	External input and output PCB bracket	UTZ-GXNA	For installing the External input and output PCB.





Exterior	Part name	Model name	Summary
	Wireless LAN adapter	UTY-TFNXZ1	Remotely manage an air conditioning system using mobile devices such as smartphones and tablets.
	Modbus converter	UTY-VMSX	For connection between indoor unit with UART interface and a Modbus open network.
	KNX converter	UTY-VKSX	For connection between indoor unit with UART interface and a KNX open network.
	External switch controller	UTY-TERX	Air conditioner switching can be controlled by connecting other external sensor switches.

## Accessories ( Outdoor unit )

### Model: AOYG24KBTB

Part name	Exterior	Q'ty	Part name	Exterior	Q'ty
Installation manual		1	Drain pipe		1

### Models: AOYG30KBTB, AOYG36KBTB, AOYG45KBTB, and AOYG54KBTB

Part name	Exterior	Q'ty	Part name	Exterior	Q'ty
Installation manual		1	Drain cap		3
Drain pipe		1	One-touch bush		2

## Optional parts

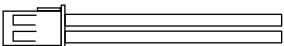
Exterior	Part name	Model name	Summary
	External connect kit	UTY-XWZXZ3	Use to operate the external input and output functions of outdoor unit. (For 30-54 models)

1907G4857