



## Assembly and Operating Manual

# Roof fan with constant pressure control

**ARU-S 190 EC CP**

**ARU-S 220 EC CP**

**ARU-S 250 EC CP**

English

The data specified above only serve to describe the product. No statements concerning a certain condition or suitability for a certain application can be derived from our information. The information given does not release the user from the obligation of own judgment and verification. It must be remembered that our products are subject to a natural process of wear and aging.

This document, as well as the data, specifications and other information set forth in it, are the exclusive property of **Cairox**. It may not be reproduced or given to third parties without its consent.

The picture on the cover shows an example configuration. The product supplied may therefore differ from the illustration.

The original manual has been produced in the German language.

Information updated: print 04.07.2018  
We reserve the right to make changes

## Assembly and Operating Manual

# Contents

<b>1. Important information</b>	<b>4</b>
1.1. Rules and regulations	5
1.2. Guarantee and liability	5
<b>2. General safety instructions</b>	<b>5</b>
2.1. Intended use	5
2.2. Improper use	5
2.3. Personnel qualifications	5
2.4. Safety instructions in this manual	6
2.5. Adhere to the following instructions	6
2.5.1. General instructions	6
2.5.2. During installation	6
2.5.3. During commissioning	6
2.5.4. During operation	7
2.5.5. During maintenance and repair	7
2.5.6. Disposal	7
<b>3. Delivery contents</b>	<b>7</b>
<b>4. Product and Performance description</b>	<b>7</b>
4.1. Device description	7
<b>5. Transport and storage</b>	<b>8</b>
<b>6. Assembly</b>	<b>8</b>
<b>7. Electrical connection</b>	<b>9</b>
<b>8. Commissioning</b>	<b>10</b>
<b>9. Operation</b>	<b>10</b>
9.1. Operation without a control unit	10
9.2. Operation with a control unit	11
9.2.1. Adjustment of the control unit parameter	11
9.2.2. Menu functions	12
9.2.3. Parameter settings Menu	12
<b>10. Maintenance and repair</b>	<b>13</b>
10.1. Important notes	13
10.2. Cleaning and care	13
<b>11. Expansion and reconfiguration</b>	<b>13</b>
<b>12. Dismantling and disposal</b>	<b>13</b>
12.1. Disposal	13
<b>13. Troubleshooting</b>	<b>14</b>
13.1. Possible operating faults.	14
<b>14. Technical data</b>	<b>14</b>
<b>15. Wiring diagrams</b>	<b>15</b>

# EC Declaration of Conformity

As required by EC Directive



## Electromagnetic Compatibility (EMC) Directive 2004/108/EC

### CAIROX BELGIUM

Hoogstraat 180  
1930 Zaventem  
Belgium

declares herewith that the following partly completed machines in their conception and design, and in the versions marketed by us comply with the requirements of the named EC directives. In the event of any changes to the partly completed machine not approved by us, this declaration loses its validity.

**Product designation:** Roof fan with constant pressure control  
**Type designation:** ARU-S 190 EC CP; ARU-S 220 EC CP; ARU-S 250 EC CP

The following harmonised standards were used:

DIN EN 61000-6-2: 2005 Electromagnetic Compatibility (EMC) - Part 6-2: Generic standards: Immunity for industrial environments.

DIN EN 61000-6-3: 2007 Electromagnetic Compatibility (EMC) - Part 6-3: Generic standards: Emission standard for residential, commercial and light-industrial environments.

Responsibility for this declaration rests with:

**CAIROX**  
Marcel Pullens (Category Manager Air Improvement)  
Hoogstraat 180  
1930 Zaventem  
Belgium

Zaventem, 01.01.2018

Marcel Pullens  
(Category Manager Air Improvement)

## 1. Important information

This manual contains important information on the safe and appropriate assembly, transport, commissioning, operation, maintenance, disassembly and simple troubleshooting of the product. The product has been manufactured according to the accepted rules of current technology. There is, however, still a danger of personal injury or damage to equipment if the following general safety instructions and the warnings before the steps contained in these instructions are not complied with.

- **Read these instructions completely and thoroughly before working with the product.**
- **Keep these instructions in a location where they are accessible to all users at all times.**
- **Always include the operating instructions when you pass the product on to third parties.**



### 1.1. Rules and regulations

Also observe the generally applicable, legal or otherwise binding regulations of the European or national legislation and the rules for the prevention of accidents and for environmental protection applicable in your country.

### 1.2. Guarantee and liability

**Cairox** products are made to the highest technical standards in accordance with the generally recognized rules of the profession. They are subject to constant quality control and meet the relevant requirements when delivered. Because the products are being constantly developed, we reserve the right to make changes to the products at any time and without prior announcement. We do not accept any liability for the correctness or completeness of this installation and operating manual.

The warranty only applies to the delivered configuration. The warranty will not apply if the product is incorrectly assembled or handled or not used as intended.



## 2. General safety instructions

Planners, plant engineers and operators are responsible for ensuring that the product is installed and operated correctly.

- Exclusively use **Cairox** Ventilatoren in good technical order and condition.
- Check the product for visible defects, for example cracks in the housing or missing rivet, screws and covers.
- Only use the product within the performance range provided in the technical data.
- Protection against contact and being sucked in and safety distances should be provided in accordance with DIN EN 13857.
- Generally prescribed electrical and mechanical protection devices are to be provided by the client.
- Safety components must not be bypassed or put out of operation.
- The product may be operated by personnel with limited physical, sensory or mental capacities only if they are supervised or have been instructed by responsible personnel.
- Children must be kept away from the product.

### 2.1. Intended use

**Cairox** ARU-S...EC CP has been designed and developed to comply with the requirements of the EU Low Voltage Directive 2006/95/EU. Use the ARU-S...EC CP only according to the described and related conditions of the EU Low Voltage Directive.

The device may only be taken into operation when it is correctly connected.

**Observe the operating conditions and performance limits specified in the technical data.**

**Intended use includes having read and understood these instructions, especially chapter 2 “General safety instructions”.**



### 2.2. Improper use

Any use of the product other than described in chapter “Intended use” is considered as improper. Also note the following points, which are improper and dangerous:

- Operation in a potentially explosive atmosphere.

### 2.3. Personnel qualifications

Assembly, commissioning and operation, disassembly and service (including maintenance and repair) require basic mechanical and electrical knowledge, as well as knowledge of the appropriate technical terms. In order to ensure operating safety, these activities may therefore only be carried out by qualified technical personnel or a person under the direction and supervision of qualified personnel. Qualified personnel are those who can recognize possible hazards and institute the appropriate safety measures due to their professional training, knowledge, and experience, as well as their understanding of the relevant conditions pertaining to the work to be done. Qualified personnel must observe the rules relevant to the subject area.





## 2.4. Safety instructions in this manual

In this manual, there are safety instructions before the steps whenever there is a danger of personal injury or damage to the equipment. The measures described to avoid these hazards must be observed.

Safety instructions are set out as follows:

**Safety sign (warning triangle)** - Draws attention to the risk

- **Type of risk** - Identifies the type or source of the hazard.
- » **Consequences** - Describes what occurs when the safety instructions are not complied with.
- **Precautions** - States how the hazard can be avoided.

Safety sign (warning triangle)	Denotation
	<b>General warning!</b> Indicates possible hazardous situations. Failure to observe the warnings may result in personal injury and / or damage to property.
	<b>Electricity warning (hazardous voltage)!</b> Indicates possible hazards due to electricity. Failure to observe the warnings may result in death, injury and/or damage to property.
	<b>Important instructions follow!</b> Instructions for safe, optimum use of the product.



## 2.5. Adhere to the following instructions

### 2.5.1. General instructions

- Observe the provisions for accident prevention and environmental protection for the country where the product is used and at the workplace.
- Persons who assemble, operate, disassemble or maintain **Cairox** products must not consume any alcohol, drugs or pharmaceuticals that may affect their ability to respond.
- Responsibilities for the operation, maintenance and regulation of the product should be clearly determined and observed so that there can be no unclear areas of responsibility with regard to safety.
- Never overload the product. Do not place anything on it.
- The warranty only applies to the delivered configuration.
- The warranty will not apply if the product is incorrectly assembled or handled or not used as intended.

### 2.5.2. During installation

- Disconnect all of the product's poles from the mains before installing the product or connecting or removing plugs. Make sure that the product cannot be switched back on again.
- Lay cables and lines so that they cannot be damaged and no one can trip over them.
- Before commissioning, make sure that all gaskets and seals in the plug-in connections are correctly fitted and undamaged in order to prevent fluids and foreign matter getting into the product.
- Information signs must not be changed or removed.

### 2.5.3. During commissioning

- Make sure that all electrical connections are either used or covered. Commission the product only if it is installed completely.

### 2.5.4. During operation

- In an emergency, or if there is a fault, or other irregularities, switch the equipment off and make sure it cannot be switched back on again.
- The technical data given on the rating plate must not be exceeded.

### 2.5.5. During maintenance and repair

- If operated correctly, **Cairox** products only require a minimum amount of maintenance. Please follow all of the instructions given in section 10 in this respect.
- Make sure that no connections or components are loosened unless the device is disconnected from the mains. Make sure that the equipment cannot be switched back on again.
- Individual components must not be interchanged. For example, the components intended for one product may not be used for other products.
- After removing fastening screws (6) (see Section 1), the housing of the air handling unit can be opened for cleaning and maintenance.

### 2.5.6. Disposal

- Dispose the product in accordance with the currently applicable national regulations in your country.

## 3. Delivery contents

Included in delivery depending on model type:

- 1 x roof fan with constant pressure control
- 1 x installation and operating manual

## 4. Product and Performance description

The **Cairox** roof fan ARU-S...EC CP with constant pressure control is used in ventilation plants to maintain a constant pressure level.

The constant pressure control is integrated in the air handling unit housing. It controls the fan speed to reach and keep the set-point of the differential pressure constant.

### 4.1. Device description

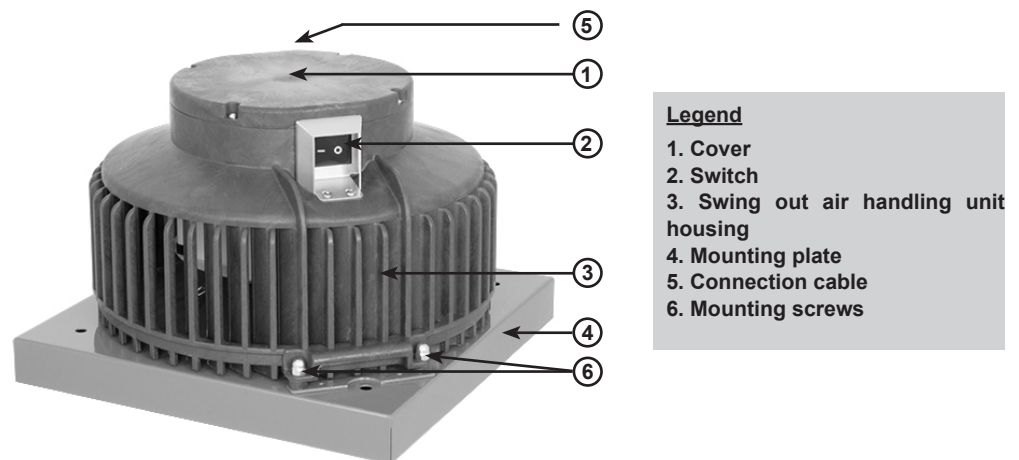

**Fig. 1:**  
Roof fan



## 5. Transport and storage

Transport and storage should only be performed by specialist personnel in accordance with the installation and operating manual and regulations in force.

The following points should be noted and followed:

- Check the delivery according to the delivery note to ensure it is complete and correct and check for any damage. Any missing quantities or damage incurred during transport should be confirmed by the carrier. No liability is accepted if this is not observed.
- Avoid damage or deformation of the housing.
- The product must be stored in a dry area and protected from the weather in the original packaging. Even weatherproof modules should be covered because their weather resistance is only guaranteed after complete installation.
- Storage temperature between  $-20\text{ }^{\circ}\text{C}$  and  $+40\text{ }^{\circ}\text{C}$ . Avoid severe temperature fluctuations.



## 6. Assembly

Assembly work may only be performed by specialist personnel in accordance with the installation and operating manual and the regulations and standards in force.

The following points should be noted and followed:

- Installation accessories should be provided by the client.
- Only suitable installation aids, in accordance with regulations, should be used.
- The installation should be easily accessible for maintenance and cleaning and should be easy to dismantle.
- The unit should only be installed with authorized and suitable fastening materials at all fastening points.
- Do not distort the unit when installing.
- No holes should be made in the housing, or any screws screwed into it.



- **The shorter pressure measurement hose must stay connected to fresh air. Install the hose in a way to prevent ingress of water.**
- **The longer pressure measurement hose has to be installed inside the duct that has to be regulated (negative pressure). Check leak tightness while installing.**

### Legend

1. Cover
2. Constant pressure control
3. Mounting screws
4. Roof fan
5. Connection cable
6. Pressure measurement hose
7. Roof socket (Accessories)

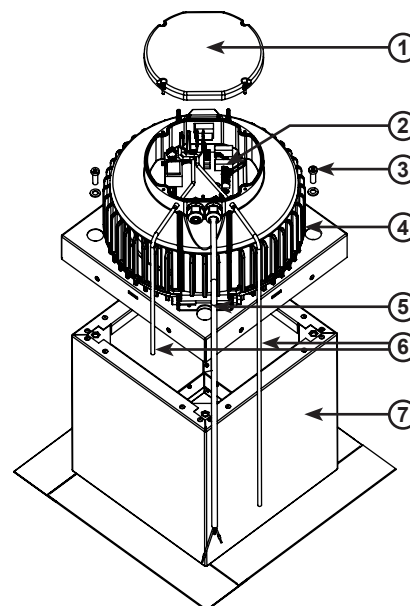

**Fig. 2:**  
Assembly size ARU-S...EC CP



## 7. Electrical connection



- **Electricity warning (hazardous voltage)!**
- » **Failure to observe the hazard may result in death, injury or damage to property.**
- **Before performing any work on conductive parts, always disconnect the unit completely from the electricity supply and make sure that it cannot be switched back on again.**

Electrical installation may only be performed by qualified electricians in accordance with the installation and operating manual and the national regulations, standards and guidelines in force:

- EN, DIN and VDE specifications, including all safety requirements.
- Technical connection conditions
- Safety at work and accident prevention requirements.

**This list does not claim to be complete. Requirements should be applied under one's own personal responsibility.**

The following points should be noted and followed:

- The electrical connections must be made as shown in the corresponding wiring diagrams and terminal diagrams.
- The type of cable, size of cable and method of laying should be determined by an authorized electrician.
- Low and extra-low voltage cables should be laid separately.
- An all-pole mains disconnection device with at least 3 mm contact gap must be provided in the supply line.
- Any cable inlets that are not used must be sealed so that it is airtight.
- All cable inlets must have strain relief.
- Check all protective measures after the electrical connection work (earthing resistance, etc.).

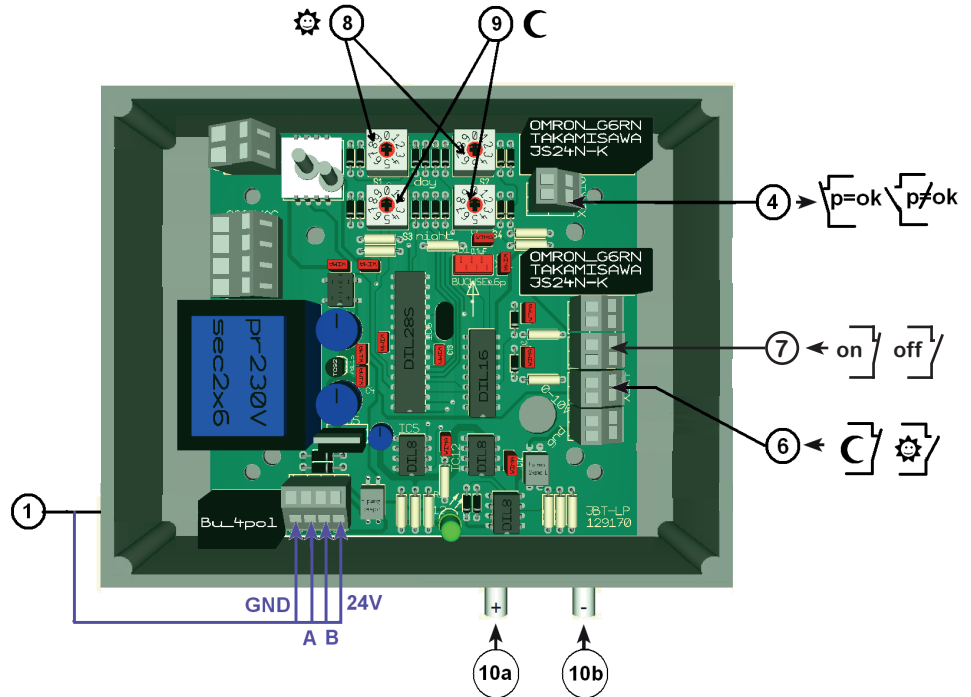

**Fig. 3:**  
Connection terminals in the regulator

- |   |  |
|---|--|
| <ul style="list-style-type: none"> <li>1. <b>Socket for control unit</b> (optionally)</li> <li>4. <b>X9, X10</b> Potential-free contact (set-point reached). <math>I_{max} = 1A</math><br/><math>U = 24V</math></li> <li>6. <b>X3, X4</b> Open: day-time operation<br/>Closed: night-time operation</li> <li>7. <b>X5, X6</b> Open: regulator OFF<br/>Closed: regulator ON</li> </ul> | <ul style="list-style-type: none"> <li>8. <b>Set-point: day</b> 10-990 Pa</li> <li>9. <b>Set-point: night</b> 10-990 Pa</li> <li>10a. <b>Pressure +</b> Pressure measurement connection for 3-6 mm internal diameter hose.</li> <li>10b. <b>Pressure -</b> Pressure measurement connection for 3-6 mm internal diameter hose.</li> </ul> |
|---|--|



Only potential-free contacts may be connected at terminals X3 and X4, and X5 and X6. Applying an external voltage can seriously damage the regulator. The regulations for safety extra-low voltages must be observed.

The maximum pressure in a ventilation plant must not exceed 5000 Pa. This would result in severe damage to the regulator.

Low voltage control leads must be installed so that they are separated from mains leads.

## 8. Commissioning



- Electricity warning (hazardous voltage)!
  - » Failure to observe the hazard may result in death, injury or damage to property.
  - Before performing any work on conductive parts, always disconnect the unit completely from the electricity supply and make sure that it cannot be switched back on again.

Commissioning by trained technical personnel may only be performed when any risk has been ruled out. The following checks should be performed in accordance with the installation and operating manual and the regulations in force:

- Check all mechanical and electrical protection measures (e.g. earthing).
- Voltage, frequency and type of current must correspond with the rating plate.
- Check all electrical connections and wiring.
- Check any electrical, switching, safety and control devices connected.
- The pressure measuring tube will be laid in the duct.
- Setting of the desired differential pressure see 9. Operation
- After checking and connecting to the electrical grid, put the switch (2) (see Fig. 1) in position „I“. The fan is starting.



## 9. Operation

### 9.1. Operation without a control unit

**CAUTION! Isolate electrical installation!** (see 8. Commissioning!)

#### Adjust set-point

After removing the cover (1) (see Fig. 1), you have free access to the pressure regulation circuit board.

Adjust set-point for the desired differential pressure at the two upper decade switches (8).

#### Switching the regulator on and off

Bridging terminals X5 and X6 switches the constant pressure regulator CON P1000 on, and removing the bridge switches it off again.

#### Turning the night mode ON and OFF

By bridging the terminals X3 and X4 the night mode is switched on, by removing the bridge, it is switched off.

#### Changing day-time set-point

Adjust set-point Day with the decade switches (8).

e.g.  $\boxed{3} \boxed{2} = 32 \times 10 = 320 \text{ Pa}$

#### Adjusting the night-time set-point

Adjust set-point Night with the decade switches (9).

e.g.  $\boxed{4} \boxed{1} = 41 \times 10 = 410 \text{ Pa}$

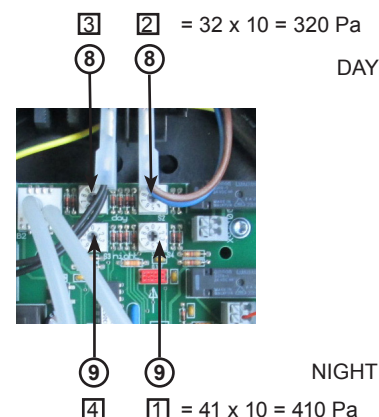
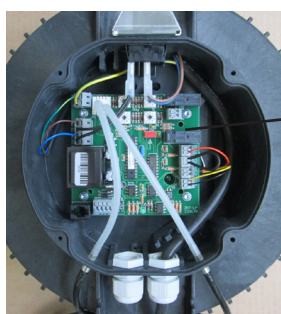

Fig. 4:  
Setting of differential pressure  
at the decade switches

## 9.2. Operation with a control unit (optionally)



**ATTENTION: When disconnecting the control unit from the unit after programming, the adjusted setpoints will be deleted. The manually adjusted setpoints by the rotary switch will then apply.**

The control unit is used for controlling and entering various functions. The display shows the various operating parameters and error messages. You can select individual menu points or change values with the various buttons.

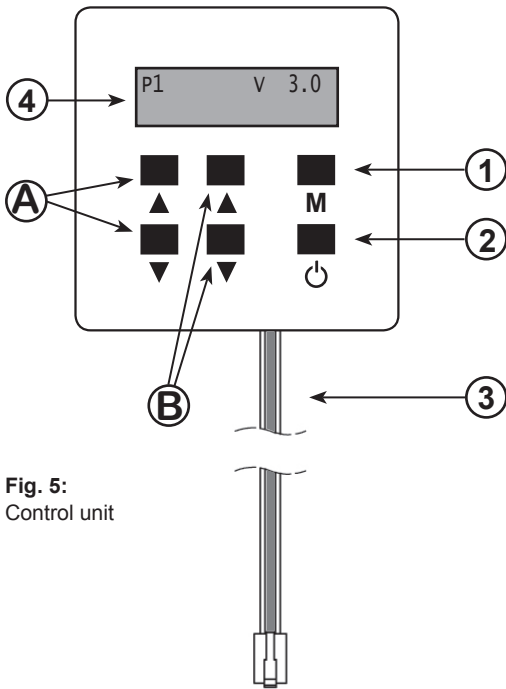

Fig. 5: Control unit

- 1) Mode Button Switches to the control unit parameter menu.
- 2) ON/OFF Button Button for switching the unit on or off or switching to menu management.
- A) Button A Buttons for increasing and decreasing the set-point for "DAY"
- B) Button B Buttons for increasing and decreasing the set-point for "NIGHT"
- 3) Control cable
- 4) Display

	150	50	PA	0
OFF				

when regulator on  
when regulator off

### 9.2.1. Adjustment of the control unit parameter

To be able to make changes to the control unit parameter, you must press the „Mode button“ (M) for at least 5 seconds. P 1 will appear on the display. Use button A (▲) to change to your desired parameter.

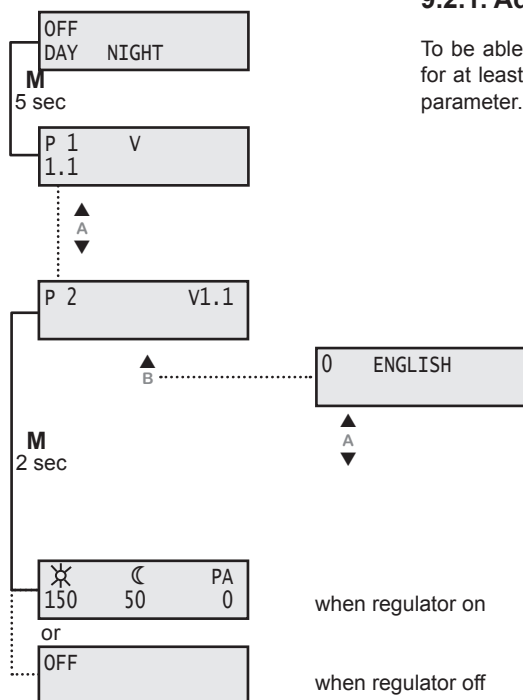

#### P 2 Language setting

Use button A (▲) to change to language setting P 2. Now press button B (▲) and the control unit will change to input mode. You can now use buttons A (▲ and ▼) to select the language required. Press button B (▲) again to accept the language selected. Then press the „Mode button“ (M) for at least 2 seconds. The parameters will be saved and the menu will close. The Display switches into operating mode.

#### P 2 Language setting

Range of values	Factory setting
0 DEUTSCH	0 DEUTSCH
1 ENGLISH	
2 FRANCAIS	
3 DANSK	
4 ESPAÑOL	
5 NEDERLANDS	
6 PORTUGUÉS	
7 POLSKI	
8	
9	

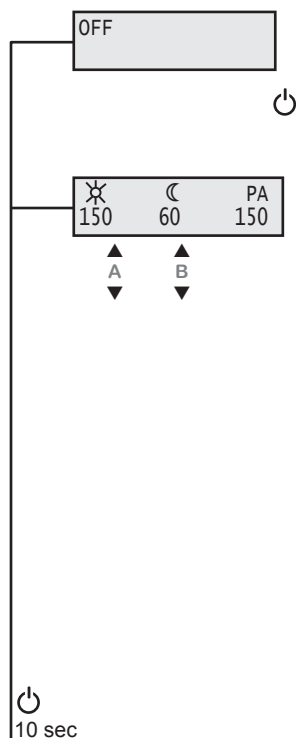

10 sec  
Parameter settings Menu  
see Section 9.2.3

### 9.2.2. Menu functions (see Fig. 5)

#### Status ON / OFF

##### Switching the unit on/off on the control unit.

Press the ON/OFF button (1) to switch the unit on or off.  
The unit's status now appears on the display with the current values.

#### Status display



##### DAY – Changing the setting

Use the A buttons on the control unit to increase (▲) or reduce (▼) the set-point.  
(The setting range is limited by parameters P01 and P02.)  
The DAY set-point is retained in memory after a power failure.



##### NIGHT - Changing the setting

Use the B buttons on the control unit to increase (▲) or reduce (▼) the set-point.  
(The setting range is limited by parameters P01 and P02.)  
The NIGHT set-point is retained in memory after a power failure.



##### Current display

Pressure difference

### 9.2.3. Parameter settings Menu

You move to the parameter settings menu menu P by pressing the ON/OFF button, which must be held down for approx. 10 seconds.

Parameter P01 is displayed on the screen. With the A (▲ and ▼) buttons on the control unit, the individual P parameters can be called up. Press the „mode button“ (M) once to return to the starting function.

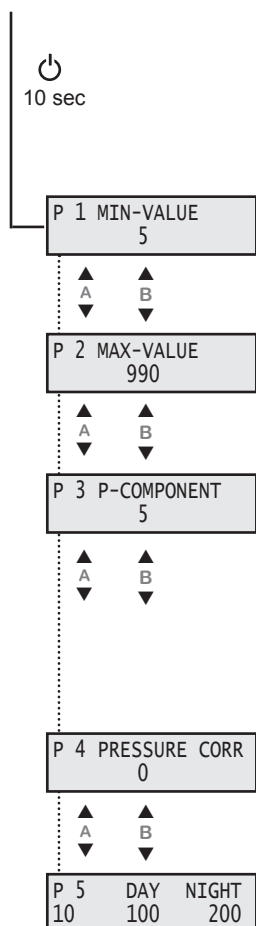

#### P 1 Minimum set-point on control unit

Parameter for display and setting of the minimum set-point.

The setting range is from 10 Pa to 500 Pa.  
The parameters can be changed with the buttons B (▲ and ▼).

#### P 2 Maximum set-point on control unit

Parameter for display and setting of the maximum set-point.

The setting range is from 100 Pa to 990 Pa.  
The parameters can be changed with the buttons B (▲ and ▼).

#### P 3 P - component

The setting range is from 5 to 15.

05 = no gain  
10 = average gain  
15 = high gain

The parameters can be changed with the buttons B (▲ and ▼).

The works setting is 5.

The regulation tends to pulsate at high gain.

#### P 4 Pressure correction

The works setting is "0".

The parameters can be changed with the buttons B (▲ and ▼).  
Settings between -20 Pa and +20 Pa are possible.

#### P 5

Control of the decade switches for Day and Night.  
The current program version is listed below „P05“.

## 10. Maintenance and repair

### 10.1. Important notes



- **Electricity warning (hazardous voltage)!**
- » Failure to observe the hazard may result in death, injury or damage to property.
- Before performing any work on conductive parts, always disconnect the unit completely from the electricity supply and make sure that it cannot be switched back on again.



Maintenance and repairs may only be performed by specialist personnel in accordance with this installation and operating manual and the regulations in force.

Do not repair defective or damaged units yourself, but report the damage or faults to the manufacturer in writing.



- **Unauthorized repairs may cause personal injury and / or damage to property, in which case the manufacturer's guarantee or warranty will not apply.**

### 10.2. Cleaning and care

**Servicing, troubleshooting and cleaning may only be performed by specialist personnel in accordance with this installation and operating manual and the regulations in force.**

If operated correctly, **Cairox** products only require a small amount of maintenance.

The following work should be performed at regular intervals, in accordance with health and safety regulations:

- Check the operation of the control system and safety devices.
- Check electrical connections and wiring for damage.
- Pressure fittings and hoses should be checked regularly for impurities and, if necessary, they should be cleaned, respectively the pressure hoses should be replaced.



**Before putting back into service after care and maintenance work, carry out a safety check as described in Sections 7 + 8!**

## 11. Expansion and reconfiguration

The unit must not be reconfigured.

**Cairox Ventilatoren's warranty only applies for the configuration delivered. The warranty will cease to apply after any reconfiguration or expansion.**



## 12. Dismantling and disposal



- **Risk of injury if dismantled under hazardous voltage!**
- » If you do not switch off the voltage before starting to dismantle the unit you may injure yourself and damage the product or parts of the installation.
- Make sure that the relevant parts of the installation have been disconnected from the voltage supply.

### 12.1. Disposal

Careless disposal of the unit may cause pollution.

Please therefore dispose of the unit in accordance with the national requirements that apply in your country.



### 13. Troubleshooting

**Please note the following instructions:**

- Proceed systematically and purposefully when troubleshooting, even when under the pressure of time.  
In the worst case, randomly and indiscriminately dismantling and changing settings may result in it no longer being possible to determine the original cause of the fault.
- Get an overview of the unit's operation in conjunction with the overall installation.
- Try to clarify whether the unit provided the required function in the overall installation before the fault occurred.
- Try to find any changes to the overall installation in which the unit is installed:
  - » Have the unit's operating conditions or operating range been changed?
  - » Have any changes (e.g. reconfigurations) or repairs been performed on the overall system (installation, electrics, control) or to the unit? If yes: what?
  - » Has the unit been operated correctly?
  - » How does the fault appear?
- Form a clear idea of the cause of the fault. If necessary, question the immediate operator or the installation operator.

**If you have not been able to remove the fault, please contact the manufacturer. The contact address can be found at [www.airtradecentre.com](http://www.airtradecentre.com) or on the back cover of this operating and installation manual.**

#### 13.1. Possible operating faults.

Further faults may occur before and during operation of the unit which are not indicated by an error message on the display.

Fault	Possible causes	Fault correction
Fan does not run.	<ul style="list-style-type: none"> <li>• Unit is not connected.</li> <li>• Unit is not in position „I“.</li> <li>• No electricity supply</li> <li>• Supply lead not connected.</li> </ul>	<ul style="list-style-type: none"> <li>• Connect unit.</li> <li>• Start unit.</li> <li>• Check fuse / power supply.</li> <li>• Have electrical power supply connected by an authorised electrician.</li> </ul>
	<ul style="list-style-type: none"> <li>• Set-point value differential pressure is set to 0 Pa.</li> </ul>	<ul style="list-style-type: none"> <li>• Adjust set-point value differential pressure.</li> </ul>
No regulation!	<ul style="list-style-type: none"> <li>• Pressure measured in the wrong place</li> </ul>	<ul style="list-style-type: none"> <li>• Connect the longer pressure measurement hose to a suitable point in the ventilation duct</li> </ul>

### 14. Technical data

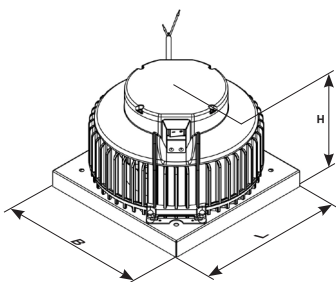

**Fig. 6:**  
Dimensions of the supply air unit

<i>Technische Daten</i>				
Gerätetyp		ARU-S 190 EC CP 20	ARU-S 220 EC CP 20	ARU-S 250 EC CP 20
		129643	129689	129703
Länge	L mm	321	321	321
Breite	B mm	321	321	321
Höhe	H mm	223,4	223	241,6
Betriebsspannung U	V	230V ~	230V ~	230V ~
Frequenz f	Hz	50	50	50
Leistungsaufnahme P	W	103	120	204
Stromaufnahme I	A	0,9	1	1,6
Max. Stromaufnahme I <sub>max</sub>	A	0,9	1,0	1,7
Max. Umgebungstemp. t <sub>A</sub>	°C	60	60	60
Max. Fördermitteltemp. t <sub>M</sub>	°C	60	60	60
Schaltplan Nr.		130426	130426	125223

Data in accordance with ErP Directive 327/2011 of the European Parliament				
Units / Model		ARU-S 190 EC-CP 20	ARU-S 220 EC-CP 20	ARU-S 250 EC-CP 20
ID-number		129643	129689	129703
ErP-conformity		2015 **	2015 **	2015
Overall efficiency	$\eta_{es}$ [%]			58,9
Measurement category				A
Efficiency category				statisch
Efficiency grade at optimum energy efficiency point	$N$			76,7
Variable speed drive				VSD integrated
Year of manufacture		see nameplate		
Commercial registration number		Local District Court Rotterdam, 22061213		
Site of manufacturer		Cairox		
Nominal motor power input at optimum energy efficiency point	$P_e$ [kW]			0,204
Volumetric flow at optimum energy efficiency point	$q_v$ [m <sup>3</sup> /h]			920
Static pressure at optimum energy efficiency point	$p_{st}$ [Pa]			452
Rotations per minute at the optimum energy efficiency point	$n$ [1/min]			2813
The specific ratio		The specific ratio is close to 1 and significantly below 1.11.		
Information on dismantling, recycling and disposal		Observe the user manual of this product.		
Optimal life		Observe the user manual of this product.		
Description of additional items used when determining the fan energy efficiency, such as ducts, that are not described in the measurement category and not supplied with the fan.		No special items have been used for determining the fan energy efficiency, except the required connection components according to the measurement category.		

\* Not ErP compliant, can be sold only as a spare part for identical fans defined by the regulation (EC) 327/2011 or outside the E.C..

\*\* Compliant to the ErP-regulation (EC) 327/2011, the power consumption at optimum efficiency is < 125W.

\*\*\* Compliant to the ErP-regulation (EC) 327/2011, the maximum power consumption of the kitchen hood is < 280W.

### 15. Wiring diagrams

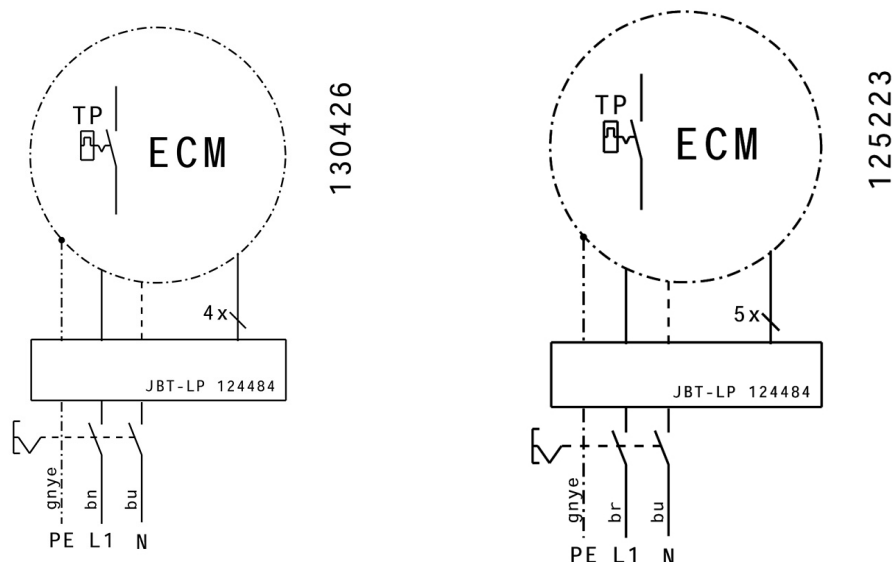

## **CAIROX**

Hoogstraat 180  
1930 ZAventem  
Belgium

[www.cairox.be](http://www.cairox.be)

The data specified above only serve to describe the product. No statements concerning a certain condition or suitability for a certain application can be derived from our information.

The information given does not release the user from the obligation of own judgment and verification.

It must be remembered that our products are subject to a natural process of wear and aging.

This document, as well as the data, specifications and other information set forth in it, are the exclusive property of **Cairox**.

It may not be reproduced or given to third parties without its consent.

Information updated:  
print 04.07.2018  
mdar\_pb\_13d\_k10031

We reserve the right to make changes

Language:  
English