

AIR CONDITIONER

**Simultaneous multi**

## SERVICE MANUAL

---

INDOOR



AUXG18KVLA × 2  
AUXG22KVLA × 2  
AUXG24KVLA × 2  
AUXG18KVLA × 3



ARXG18KLLAP × 2  
ARXG18KLLAP × 3



ARXG22KMLA × 2  
ARXG24KMLA × 2

OUTDOOR



AOYG36KRTA



AOYG45KRTA  
AOYG54KRTA

**Notices:**

- Product specifications and design are subject to change without notice for future improvement.
- For further details, please check with our authorized dealer.

**Trademarks**

FGLair™ is trademark of Fujitsu General Limited in the United States, other countries or both.

Google Play™ is trademark of Google Inc.

App Store® is a service mark of Apple Inc., registered in the U.S. and other countries.

# CONTENTS

## 1. GENERAL INFORMATION

## 2. TECHNICAL DATA AND PARTS LIST













## **1. GENERAL INFORMATION**

# CONTENTS

## 1. GENERAL INFORMATION

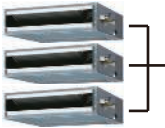
<b>1. Model lineup</b> .....	<b>01-1</b>
<b>2. Specifications</b> .....	<b>01-2</b>
2-1. Compact cassette type .....	01-2
2-2. Slim duct type .....	01-3
2-3. Medium static pressure duct type .....	01-4
2-4. Outdoor unit .....	01-5
<b>3. Dimensions</b> .....	<b>01-8</b>
3-1. Compact cassette type .....	01-8
3-2. Slim duct type .....	01-10
3-3. Duct type .....	01-12
3-4. Outdoor unit .....	01-14

# 1. Model lineup

<b>Indoor unit</b>		<b>Outdoor unit</b>
<b>Twin</b>		
<b>18 kBtu/h × 2</b>		
 ARXG18KLLAP		 AOYG36KRTA
 AUXG18KVLA		
<b>Indoor unit</b>		<b>Outdoor unit</b>
<b>Twin</b>		
<b>22 kBtu/h × 2</b>		
 ARXG22KMLA		 AOYG45KRTA
 AUXG22KVLA		
<b>Indoor unit</b>		<b>Outdoor unit</b>
<b>Twin</b>	<b>Triple</b>	
<b>24 kBtu/h × 2</b>	<b>18 kBtu/h × 3</b>	
 ARXG24KMLA	 ARXG18KLLAP	 AOYG54KRTA
 AUXG24KVLA	 AUXG18KVLA	

## 2. Specifications

### 2-1. Compact cassette type

Model name				AUXG18KVLA	AUXG22KVLA	AUXG24KVLA
Power supply				3N 400 V ~50 Hz		
Power supply intake				Outdoor unit		
Available voltage range				342—457 V		
Fan	Airflow rate	Cooling	HIGH	680	830	930
			MED	580	740	830
			LOW	490	600	600
			QUIET	410		450
		Heating	HIGH	800	860	930
			MED	680	760	860
			LOW	580		700
			QUIET	450		530
	Type × Q'ty		Turbo fan × 1			
	Motor output		W			
		54				
Sound pressure level*1	Cooling	HIGH	38	44	49	
		MED	34	42	44	
		LOW	30	36	36	
		QUIET	26	30	30	
	Heating	HIGH	43	45	49	
		MED	38	43	45	
		LOW	34		40	
		QUIET	30		33	
Heat exchanger type	Dimensions (H × W × D)		mm	210 × 1,310 × 13.3 210 × 1,250 × 13.3		
	Fin pitch		mm	1.20		
	Rows × Stages			2 × 10		
	Pipe type			Copper tube		
	Fin type			Aluminum		
Dimensions (H × W × D)	Net		mm	245 × 570 × 570		
	Gross			265 × 730 × 625		
Weight	Net		kg	15		
	Gross			19		
Connection pipe	Size	Liquid	mm (in)	Ø 6.35 (1/4)		
		Gas		Ø 12.70 (1/2)		
	Method			Flare		
Operation range	Cooling		°C	18 to 32		
			%RH	80 or less		
	Heating		°C	16 to 30		
Drain hose	Material			PVC		
	Size		mm	Ø 25 (I.D.), Ø 32 (O.D.)		
Cassette grille (Option)	Model name			UTG-UFYF-W		
	Material			PS		
	Color			White		
				Approximate color of Munsell 9PB 9.1/0.2		
	Dimensions (H × W × D)	Net		mm	49 × 620 × 620	
		Gross			120 × 765 × 755	
Weight	Net		kg	2.3		
	Gross			4.5		
Remote controller type (option)				Wired remote controller, Wireless remote controller, Mobile app*2 (FGLair™)		
<b>NOTES:</b> <ul style="list-style-type: none"> <li>The protective function might work when using it outside the operation range.</li> <li>*1: Sound pressure level: <ul style="list-style-type: none"> <li>These are the measured values in the manufacturer's anechoic chamber.</li> <li>Because of the surrounding sound environment, the sound levels measured in actual installation conditions might be higher than the specified values here.</li> </ul> </li> <li>*2: Available on Google Play™ store or on App Store®. Optional WLAN adapter is also required. For details, refer to the setting manual.</li> </ul>						



## 2-2. Slim duct type

Model name				ARXG18KLLAP
Power supply				3N 400 V ~50 Hz
Power supply intake				Outdoor unit
Available voltage range				342–457 V
Fan	Airflow rate	Cooling	HIGH	940
			MED	880
			LOW	820
			QUIET	750
		Heating	HIGH	940
			MED	880
			LOW	820
			QUIET	750
	Type × Q'ty			Sirocco fan × 3
	Motor output			W 96
Recommended static pressure			Pa 0 to 90	
Sound pressure level*1	Cooling	HIGH	32	
		MED	30	
		LOW	29	
		QUIET	27	
	Heating	HIGH	32	
		MED	30	
		LOW	29	
		QUIET	27	
Heat exchanger type	Dimensions (H × W × D)		mm 294 × 700 × 39.9	
	Fin pitch		mm 1.30	
	Rows × Stages		3 × 14	
	Pipe type		Copper tube	
	Fin type		Aluminum	
Enclosure	Material			Steel sheet
	Color			—
Dimensions (H × W × D)	Net		mm 198 × 900 × 620	
	Gross		mm 276 × 1,168 × 772	
Weight	Net		kg 20	
	Gross		kg 26	
Connection pipe	Size	Liquid	mm (in) Ø 6.35 (1/4)	
		Gas	mm (in) Ø 12.70 (1/2)	
	Method		Flare	
Operation range	Cooling	°C	18 to 32	
		%RH	80 or less	
	Heating	°C	16 to 30	
Drain hose	Material			PVC
	Size		mm	Ø 25 (I.D.), Ø 32 (O.D.)
Remote controller type (option)				Wired remote controller, Wireless remote controller, Mobile app*2 (FGLair™)
<b>NOTES:</b>				
<ul style="list-style-type: none"> <li>• Values mentioned in the table are based on the following conditions: <ul style="list-style-type: none"> <li>– Static pressure: 25 Pa</li> </ul> </li> <li>• The protective function might work when using it outside the operation range.</li> <li>• *1: Sound pressure level: <ul style="list-style-type: none"> <li>– These are the measured values in the manufacturer's anechoic chamber.</li> <li>– Because of the surrounding sound environment, the sound levels measured in actual installation conditions might be higher than the specified values here.</li> </ul> </li> <li>• *2: Available on Google Play™ store or on App Store®. Optional WLAN adapter is also required. For details, refer to the setting manual.</li> </ul>				

## 2-3. Medium static pressure duct type

Model name				ARXG22KMLA	ARXG24KMLA	
Power supply				3N 400 V ~50 Hz		
Power supply intake				Outdoor unit		
Available voltage range				342—457 V		
Fan	Airflow rate	Cooling	HIGH	m <sup>3</sup> /h	1,100	
			MED		910	
			LOW		750	
			QUIET		580	
		Heating	HIGH		1,100	
			MED		910	
			LOW		750	
			QUIET		580	
	Type × Q'ty				Sirocco fan × 2	
	Motor output				W	
Recommended static pressure				Pa		
Sound pressure level <sup>*1</sup>	Cooling	HIGH	dB (A)	31		
		MED		29		
		LOW		27		
		QUIET		25		
	Heating	HIGH		31		
		MED		29		
		LOW		27		
		QUIET		25		
Heat exchanger type	Dimensions (H × W × D)		mm	294 × 1,000 × 39.9		
	Fin pitch		mm	1.40		
	Rows × Stages			3 × 14		
	Pipe type			Copper		
	Fin type			Aluminum		
Enclosure	Material			Steel sheet		
	Color			—		
Dimensions (H × W × D)	Net		mm	270 × 1,135 × 700		
	Gross			300 × 1,320 × 790		
Weight	Net		kg	35		
	Gross			43		
Connection pipe	Size	Liquid	mm (in)	Ø 6.35 (1/4)		
		Gas		Ø 12.70 (1/2)		
	Method			Flare		
Operation range	Cooling		°C	18 to 32		
			%RH	80 or less		
	Heating		°C	16 to 30		
Drain port	Material			Steel		
	Size		mm	Ø 35.7 (I.D.), Ø 38.1 (O.D.)		
Remote controller type (option)				Wired remote controller, Wireless remote controller, Mobile app <sup>*2</sup> (FGLair™)		
<b>NOTES:</b> <ul style="list-style-type: none"> <li>• Values mentioned in the table are based on the following conditions: <ul style="list-style-type: none"> <li>– Static pressure: 35 Pa</li> </ul> </li> <li>• The protective function might work when using it outside the operation range.</li> <li>• <sup>*1</sup>: Sound pressure level: <ul style="list-style-type: none"> <li>– These are the measured values in the manufacturer's anechoic chamber.</li> <li>– Because of the surrounding sound environment, the sound levels measured in actual installation conditions might be higher than the specified values here.</li> </ul> </li> <li>• <sup>*2</sup>: Available on Google Play™ store or on App Store®. Optional WLAN adapter is also required. For details, refer to the setting manual.</li> </ul>						

## 2-4. Outdoor unit

Type				Inverter heat pump		
Model name				AOYG36KRTA	AOYG45KRTA	AOYG54KRTA
Power supply				3N 400 V ~ 50 Hz		
Power supply intake				Outdoor unit		
Available voltage range				342—457 V		
Indoor unit combination				AUXG18KVLA × 2 ARXG18KLLAP × 2	AUXG22KVLA × 2 ARXG22KMLA × 2	AUXG24KVLA × 2 ARXG24KMLA × 2 AUXG18KVLA × 3 ARXG18KLLAP × 3
Capacity	Cooling	Rated	kW	9.5	12.1	13.4
			Btu/h	32,400	41,300	45,700
		Min.—Max.	kW	2.8—11.2	4.0—13.0	4.5—14.5
	Heating	Rated	Btu/h	9,500—38,200	13,700—44,300	15,300—49,400
			kW	10.8	13.5	15.5
		Min.—Max.	Btu/h	36,800	46,000	52,900
Input power	Cooling	Rated	kW	2.97	4.22	4.42
			Max.	4.29	5.03	5.39
		Heating	Rated	2.88	3.84	4.16
	Heating	Rated	kW	4.66	4.79	4.88
			Max.	5.7	7.7	8.0
		Current	Cooling	Max.	10.5	14.0
Heating	Rated	A	5.6	7.1	7.6	
		Max.	10.5	14.0	14.0	
	EER	Cooling		3.20	2.87	3.03
COP	Heating		3.75	3.52	3.73	
Power factor	Cooling		75.4	79.6	80.4	
	Heating		75.1	78.2	79.4	
Starting current			A	5.7	7.7	5.7
Maximum operating current*1			A	10.5	14.0	10.5
Fan	Airflow rate	Cooling	m <sup>3</sup> /h	3,750	4,450	3,750
		Heating		3,750	4,450	3,750
	Type × Q'ty		Propeller × 1			
	Motor output		W	100	120	120
Sound pressure level*2	Cooling	Heating	dB (A)	55	57	59
				70	71	73
Sound power level	Cooling	Heating	dB (A)	70	71	73
				70	71	73
Heat exchanger type	Dimensions (H × W × D)	mm	Main1: 756 × 905 × 18.19 Main2: 756 × 905 × 18.19	Main1: 966 × 905 × 18.19 Main2: 966 × 905 × 18.19 Sub: 966 × 543 × 18.19		
			Fin pitch	Main1: 1.45 Main2: 1.45	Main1: 1.45 Main2: 1.45 Sub: 1.45	
	Rows × Stages		Main1: 1 × 36 Main2: 1 × 36	Main1: 1 × 46 Main2: 1 × 46 Sub: 1 × 46		
	Pipe type		Copper			
	Fin	Type (Material)		Aluminum		
		Surface treatment		Blue fin		
Compressor	Type × Q'ty		DC Twin rotary × 1			
	Motor output		W	1,500	2,180	2,180
Refrigerant	Type (Global warming potential)		R32 (675)			
	Factory charge		g	1,900	2,700	2,700
Refrigerant oil	Type		FW68D	RmM68AF		
	Amount		cm <sup>3</sup>	600	800	800
Enclosure	Material		Steel sheet			
	Color		Beige			
Dimensions (H × W × D)	Net		788 × 940 × 320	998 × 940 × 320		
	Gross		966 × 1,027 × 445	1,176 × 1,027 × 445		
Weight	Net		53	67		
	Gross		62	77		
Connection pipe	Size	Liquid	mm (in)	Ø9.52 (3/8)		
		Gas		Ø15.88 (5/8)		
	Method		Flare			
	Pre-charge length		Total	30		
	Max. length (Total)			50		
	Max. length (From the 1st separation tube)	To the farthest indoor unit		20		
		To the farthest indoor unit—To the nearest indoor unit		8		
	Max. height difference between outdoor unit and each indoor units		30			
Max. height difference between indoor units		0.5				
Operation range	Cooling		-15 to 46			
	Heating		-15 to 24			
Drain hose	Material		LDPE			
	Size		Ø13.0 (I. D.), Ø16.0 to Ø16.8 (O. D.)			

Type	Inverter heat pump		
Model name	AOYG36KRTA	AOYG45KRTA	AOYG54KRTA
<b>NOTES:</b> <ul style="list-style-type: none"> <li>• Specifications are based on the following conditions: <ul style="list-style-type: none"> <li>– Cooling: Indoor temperature of 27 °CDB/19 °CWB, and outdoor temperature of 35 °CDB/24 °CWB.</li> <li>– Heating: Indoor temperature of 20 °CDB/15 °CWB, and outdoor temperature of 7 °CDB/6 °CWB.</li> <li>– Pipe length: 5.0 m, Height difference: 0 m. (Between outdoor unit and indoor unit.)</li> </ul> </li> <li>• Protective function might work when using it outside the operation range.</li> <li>• *1: Maximum operating current is the total current of the indoor unit and the outdoor unit.</li> <li>• *2: Sound pressure level <ul style="list-style-type: none"> <li>– Measured values in manufacturer's anechoic chamber.</li> <li>– Because of the surrounding sound environment, the sound levels measured in actual installation conditions might be higher than the specified values here.</li> </ul> </li> </ul>			

Specifications for ErP Lot10				
Model name			AOYG36KRTA	
Energy efficiency class	Cooling		A++	
	Heating (Average)		A+	
Pdesign	Cooling	kW	9.5 (35°C)	
	Heating (Average)		8.7 (-10°C)	
SEER	Cooling	kWh/kWh	6.1	
SCOP	Heating (Average)		4.0	
Annual energy consumption	QCE		545	
	QHE (Average)		3,044	
Sound power level	Cooling	HIGH	dB (A)	70
	Heating			70

### 3. Dimensions

#### 3-1. Compact cassette type

##### ■ Models: AUXG18KVLA, AUXG22KVLA, and AUXG24KVLA

Unit: mm

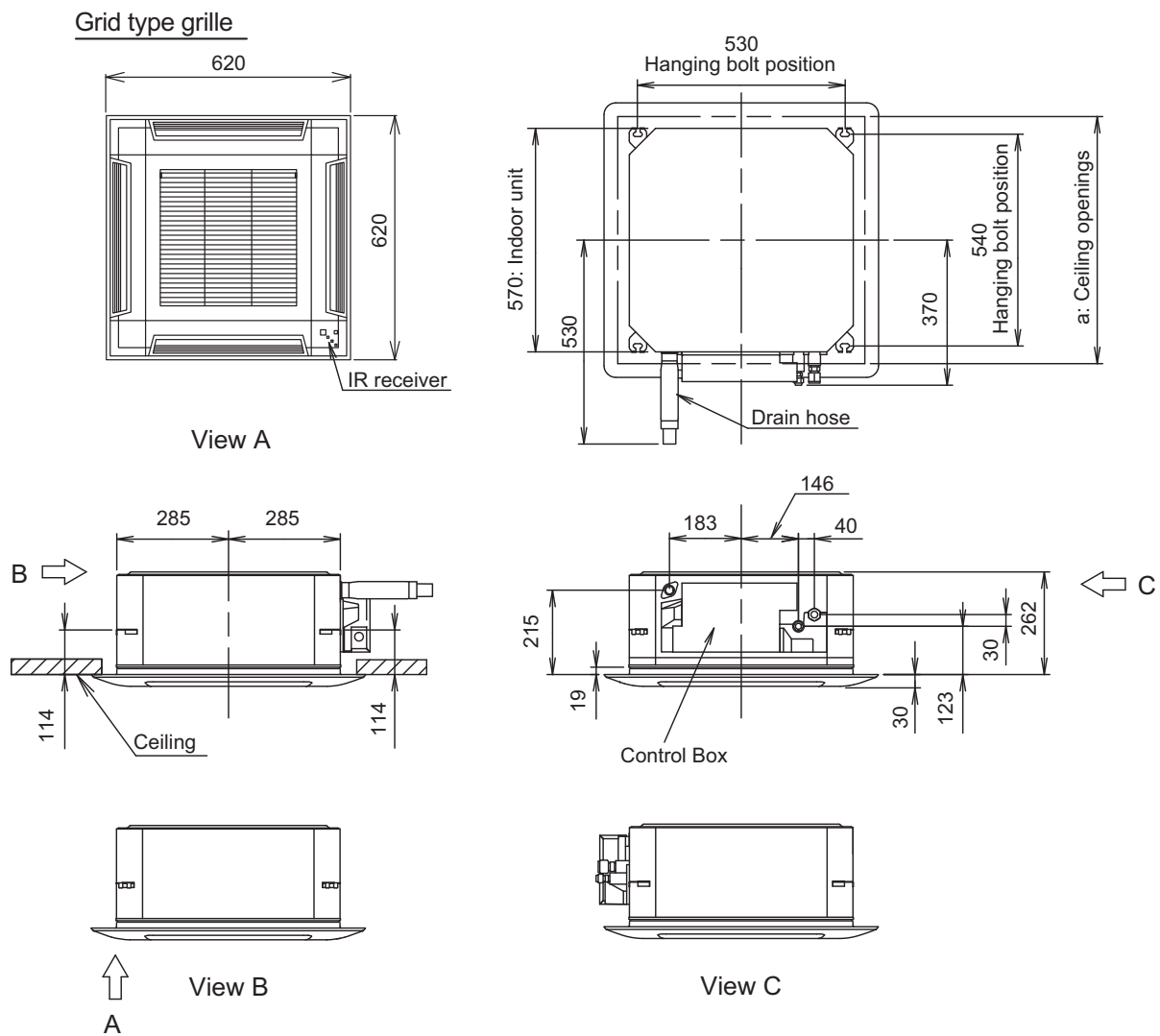

a: Ceiling openings		
Cassette grille (Option [Grid type])	mm	580 to 610

## ■ Installation space requirement

Unit: mm

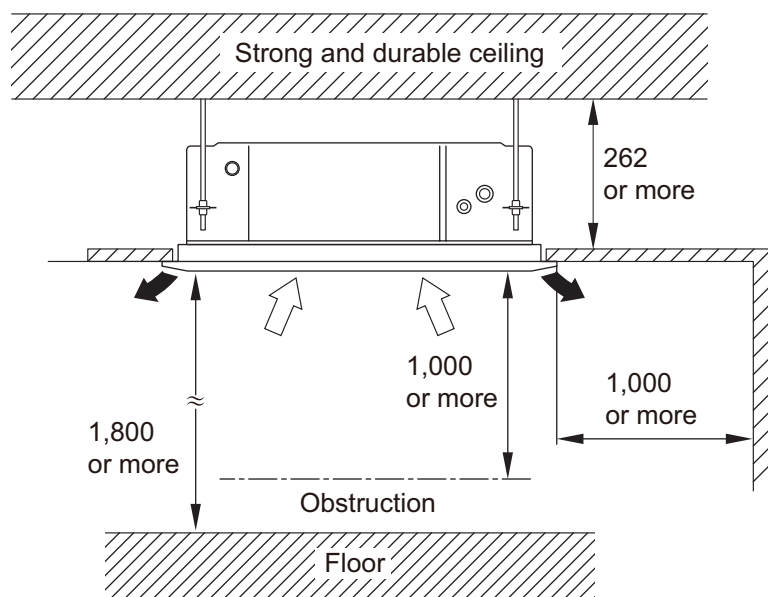

Maximum height from floor to ceiling (Unit: mm)	
Standard	2,700
High ceiling	3,000

### 3-way direction setting:

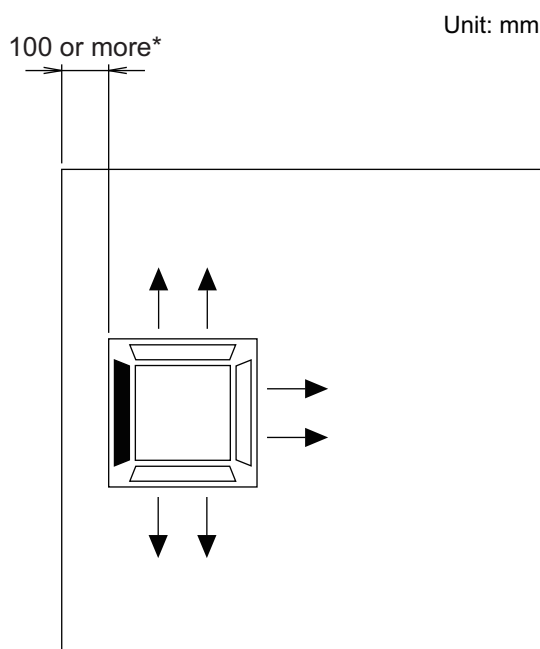

### NOTES:

- To set "3-direction", optional Air outlet shutter plate (UTR-YDZB) must be installed, and the "outlet-direction" need to be switched to "3-way" by remote controller.  
\*When installing the indoor unit, be careful about the maintenance space.
- In 3-way outlet mode, changing of ceiling height setting by function setting 20 is prohibited.  
(Ceiling height setting [function setting 20] is allowed to be changed only in 4-way outlet mode.)

### 3-2. Slim duct type

#### ■ Model: ARXG18KLLAP

Unit: mm

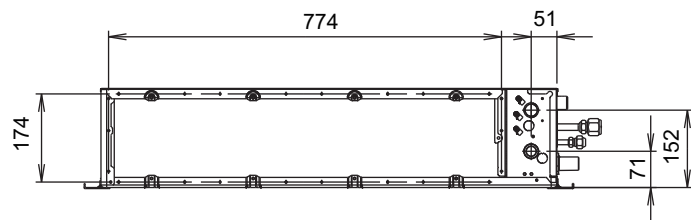

Rear view

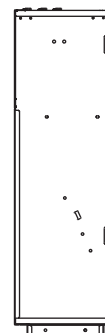

View A

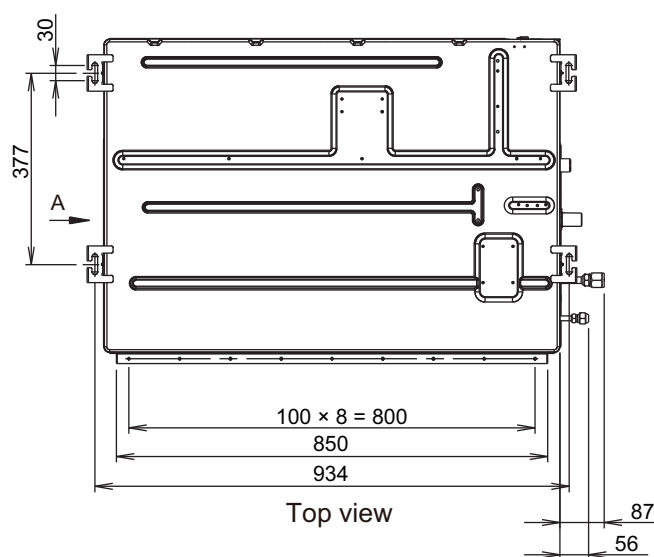

Top view

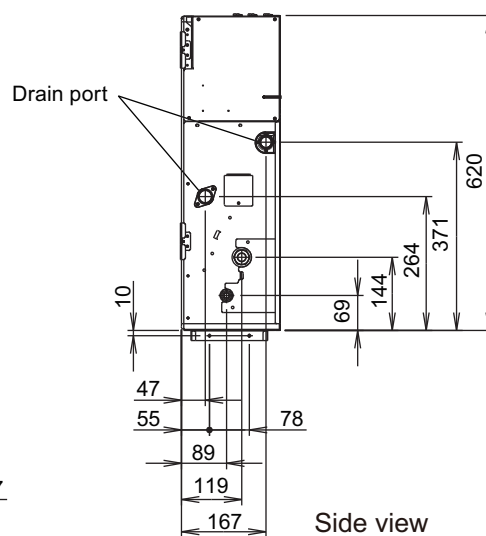

Side view

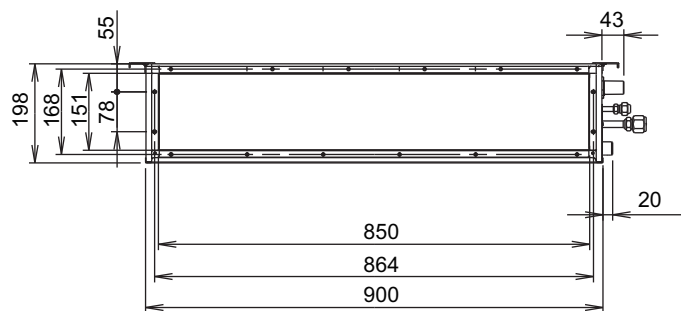

Front view

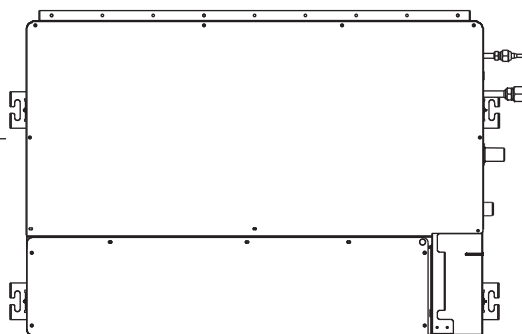

Bottom view



## ■ Installation space requirement

Provide sufficient installation space for product safety.

### In ceiling-concealed installations:

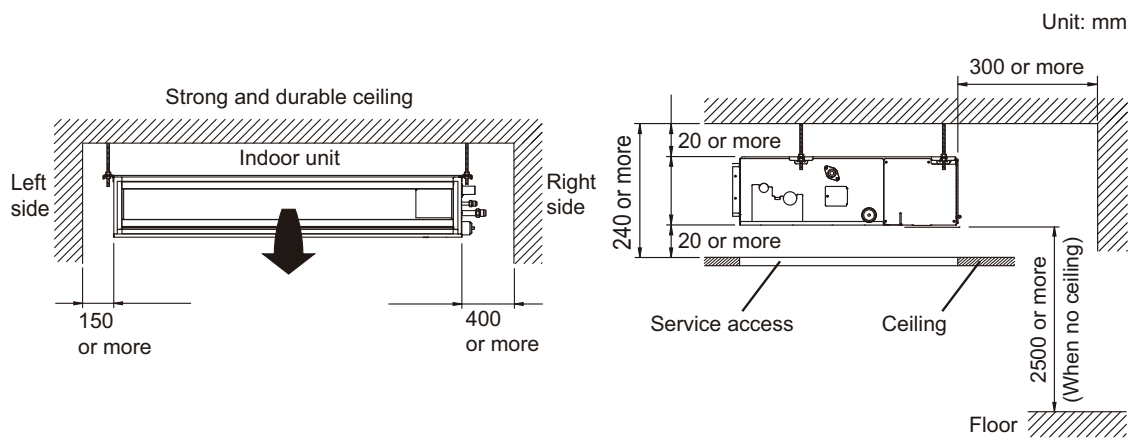



- Bottom air intake hole

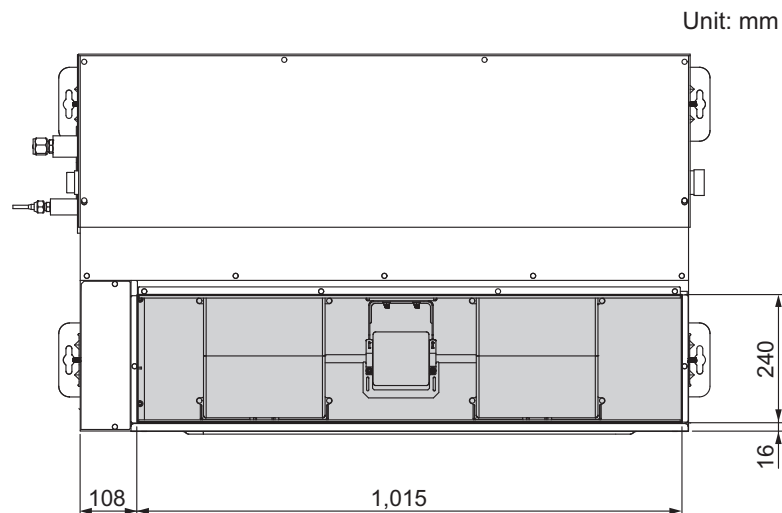

## ■ Installation space requirement

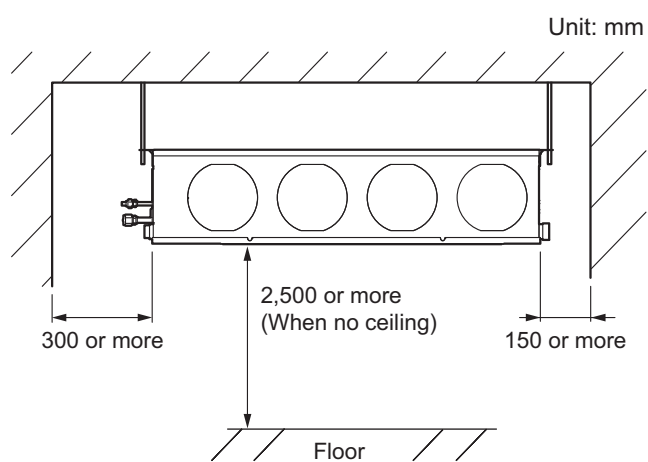

### 3-4. Outdoor unit

#### Model: AOYG36KRTA

Unit: mm

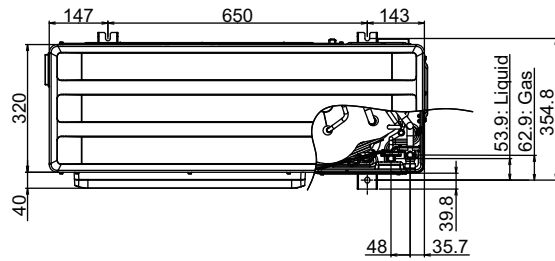

Top view

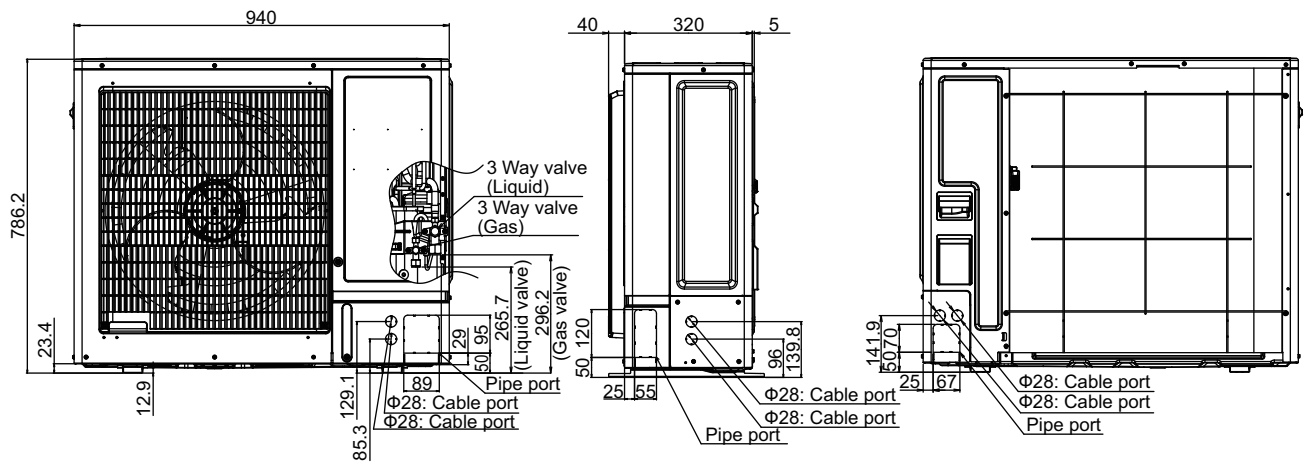

Front view

Side view

Rear view

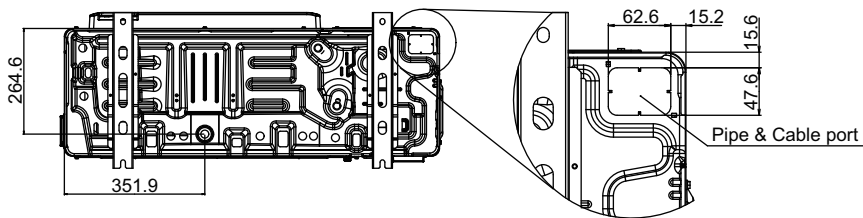

Bottom view

Models: AOYG45KRTA and AOYG54KRTA

Unit: mm

GENERAL INFORMATION

GENERAL INFORMATION

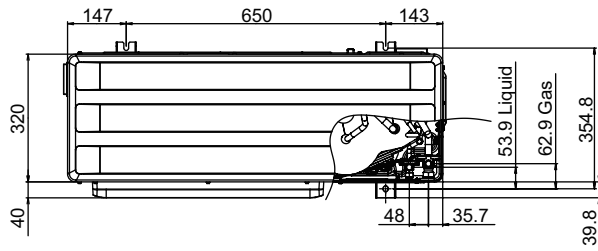

Top view

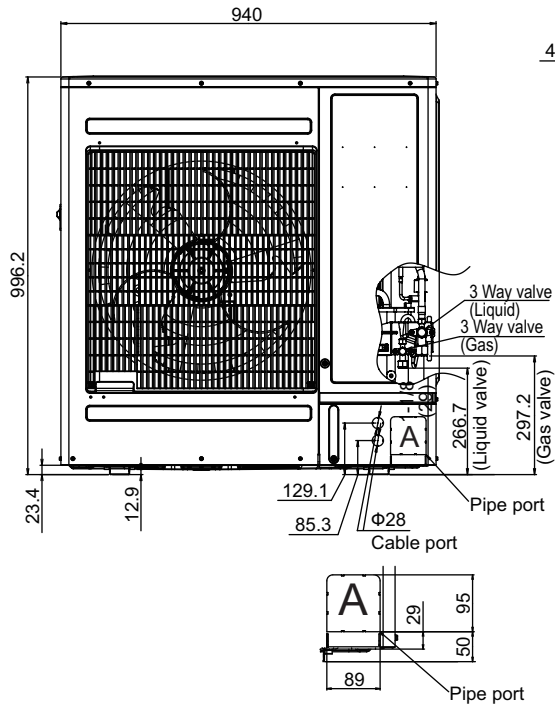

Front view

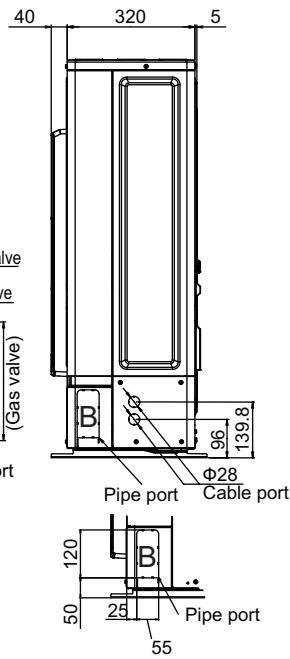

Side view

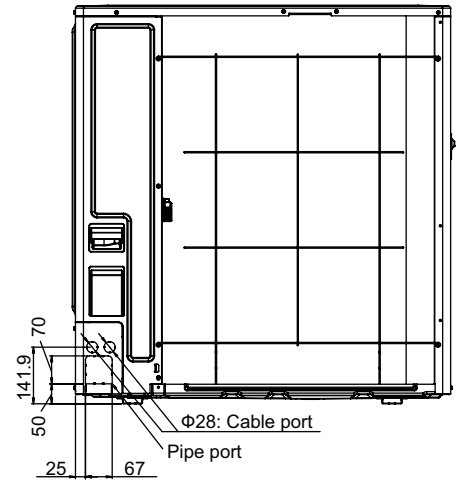

Rear view

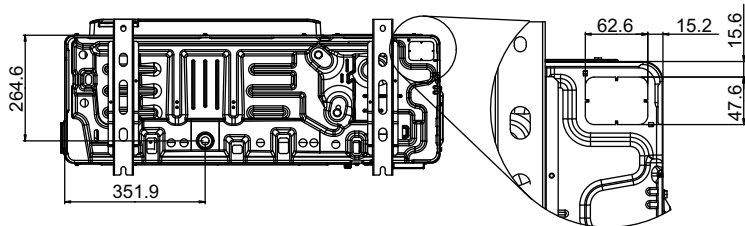

Bottom view

Pipe & Cable port

## **2. TECHNICAL DATA AND PARTS LIST**

# CONTENTS

## 2. TECHNICAL DATA AND PARTS LIST

<b>1. Precautions</b> .....	<b>02-1</b>
<b>2. Cassette grille (optional part) parts list</b> .....	<b>02-2</b>
2-1. Model: UTG-UFYF-W .....	02-2
<b>3. Indoor unit parts list</b> .....	<b>02-6</b>
3-1. Models: AUXG18KVLA, AUXG22KVLA, and AUXG24KVLA .....	02-6
3-2. Model: ARXG18KLLAP .....	02-11
3-3. Models: ARXG22KMLA and ARXG24KMLA .....	02-14
<b>4. Outdoor unit parts list</b> .....	<b>02-18</b>
4-1. Model: AOYG36KRTA.....	02-18
4-2. Models: AOYG45KRTA and AOYG54KRTA .....	02-22
<b>5. Accessories</b> .....	<b>02-26</b>
5-1. Indoor unit .....	02-26
5-2. Outdoor unit.....	02-28
<b>6. Optional parts</b> .....	<b>02-29</b>
6-1. Branch pipes.....	02-29
6-2. Controllers .....	02-31
6-3. Cassette grille.....	02-32
6-4. Others.....	02-33
<b>7. Refrigerant system diagrams</b> .....	<b>02-36</b>
7-1. Models: AOYG36KRTA, AOYG45KRTA, and AOYG54KRTA .....	02-36
<b>8. PC board diagrams</b> .....	<b>02-37</b>
8-1. Models: AUXG18KVLA, AUXG22KVLA, and AUXG24KVLA .....	02-37
8-2. Model: ARXG18KLLAP .....	02-38
8-3. Models: ARXG22KMLA and ARXG24KMLA .....	02-39
8-4. Models: AOYG36KRTA, AOYG45KRTA, and AOYG54KRTA .....	02-40





# 1. Precautions

When you start servicing, pay attention to the following points. For detailed precautions, refer to the installation manual of the products.

## **⚠ CAUTION**

---

- Service personnel
    - Any person who is involved with working on or breaking into a refrigerant circuit should hold a current valid certificate from an industry-accredited assessment authority, which authorizes their competence to handle refrigerants safely in accordance with an industry recognized assessment specification.
    - Servicing shall only be performed as recommended by the equipment manufacturer. Maintenance and repair requiring the assistance of other skilled personnel shall be carried out under the supervision of the person competent in the use of flammable refrigerants.
    - Servicing shall be performed only as recommended by the manufacturer.
  - Work
    - Prior to beginning work on systems containing flammable refrigerants, safety checks are necessary to ensure that the risk of ignition is minimized. When repairing the refrigerant system, refer to the precautions written in the installation manual of the products before you start servicing.
    - Work shall be undertaken under a controlled procedure so as to minimize the risk of a flammable gas or vapor being present while the work is being performed.
    - All maintenance staff and others working in the local area shall be instructed on the nature of work being carried out.
    - Work in confined spaces shall be avoided.
    - The area around the workspace shall be sectioned off.
    - Ensure that the conditions within the area have been made safe by control of flammable material.
  - Checking for presence of refrigerant
    - The area shall be checked with an appropriate refrigerant detector prior to and during work, to ensure the technician is aware of potentially flammable atmospheres.
    - Ensure that the leak detection equipment being used is suitable for use with flammable refrigerants, i.e. non-sparking, adequately sealed or intrinsically safe.
- 
- Service parts information and design are subject to change without notice for product improvement.
  - For the latest information of the service parts, refer to our Service Portal.  
<https://fujitsu-general.force.com/portal/>
  - Precise figure of the service parts listed in this manual may differ from the actual service parts.

## 2. Cassette grille (optional part) parts list

### 2-1. Model: UTG-UFYF-W

#### ■ Panels

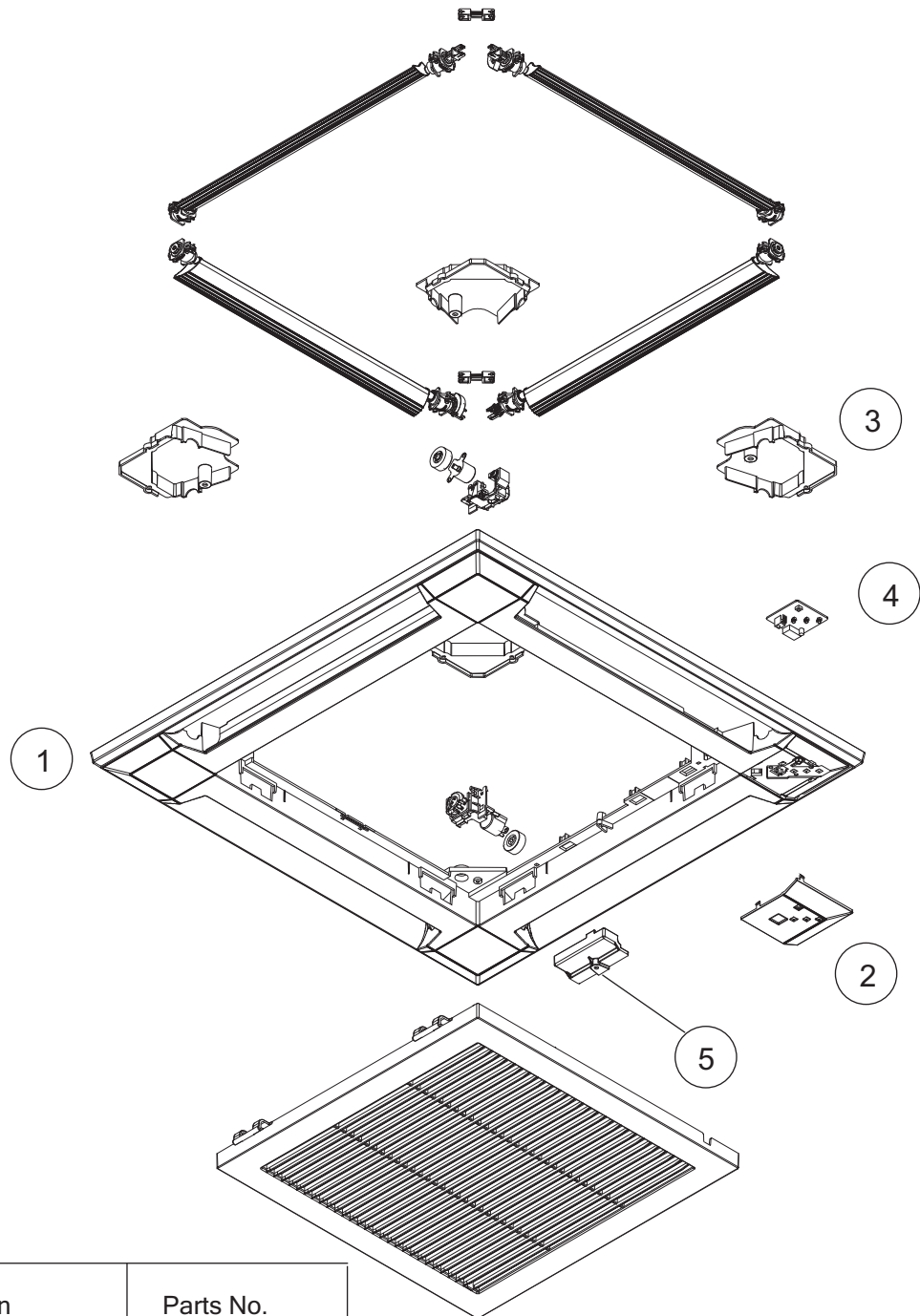

Ref	Description	Parts No.
1	Decoration Panel without Insulations	9382821005
2	Display panel assy	9383100031
3	Panel Cover without Insulations	9375530013
4	Indicator PCB	9711310002
5	Connector Cover	9375549015

# Intake grille

TECHNICAL DATA  
AND PARTS LIST

TECHNICAL DATA  
AND PARTS LIST

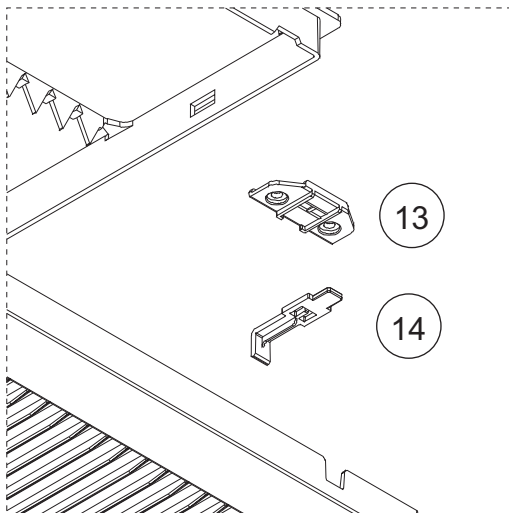
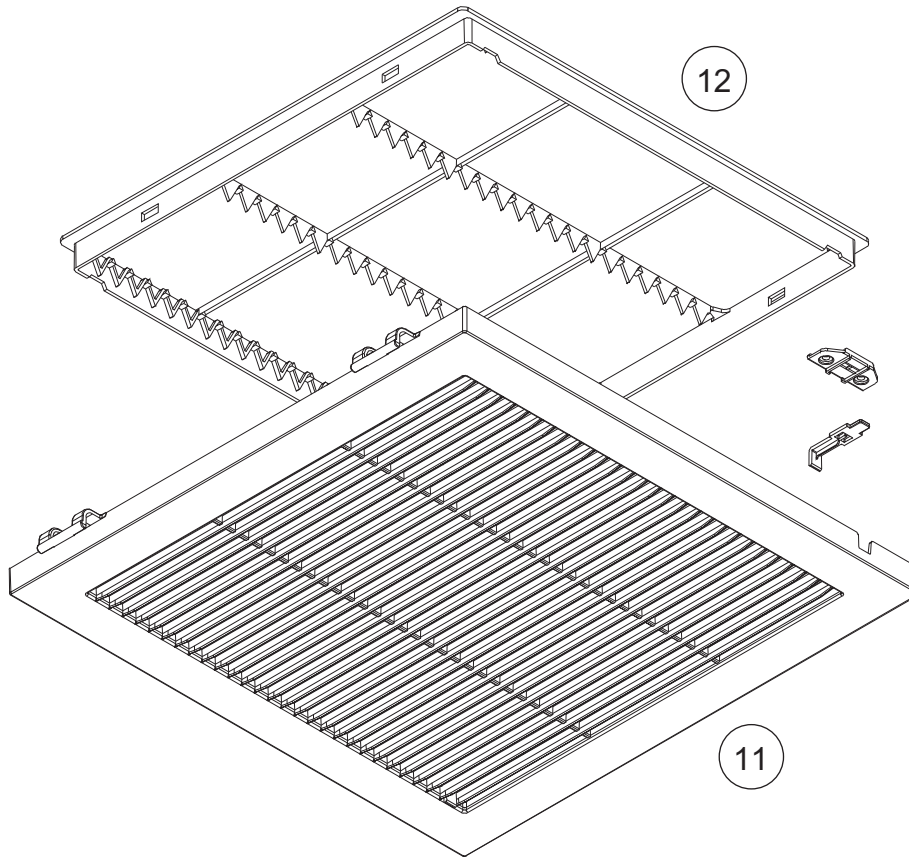

Ref	Description	Parts No.
11	Intake grille	9382863005
12	Long Life Filter	9375533014
13	Hook bracket	9375546014
14	Grille hook	9375532031

## ■ Louvers and motors

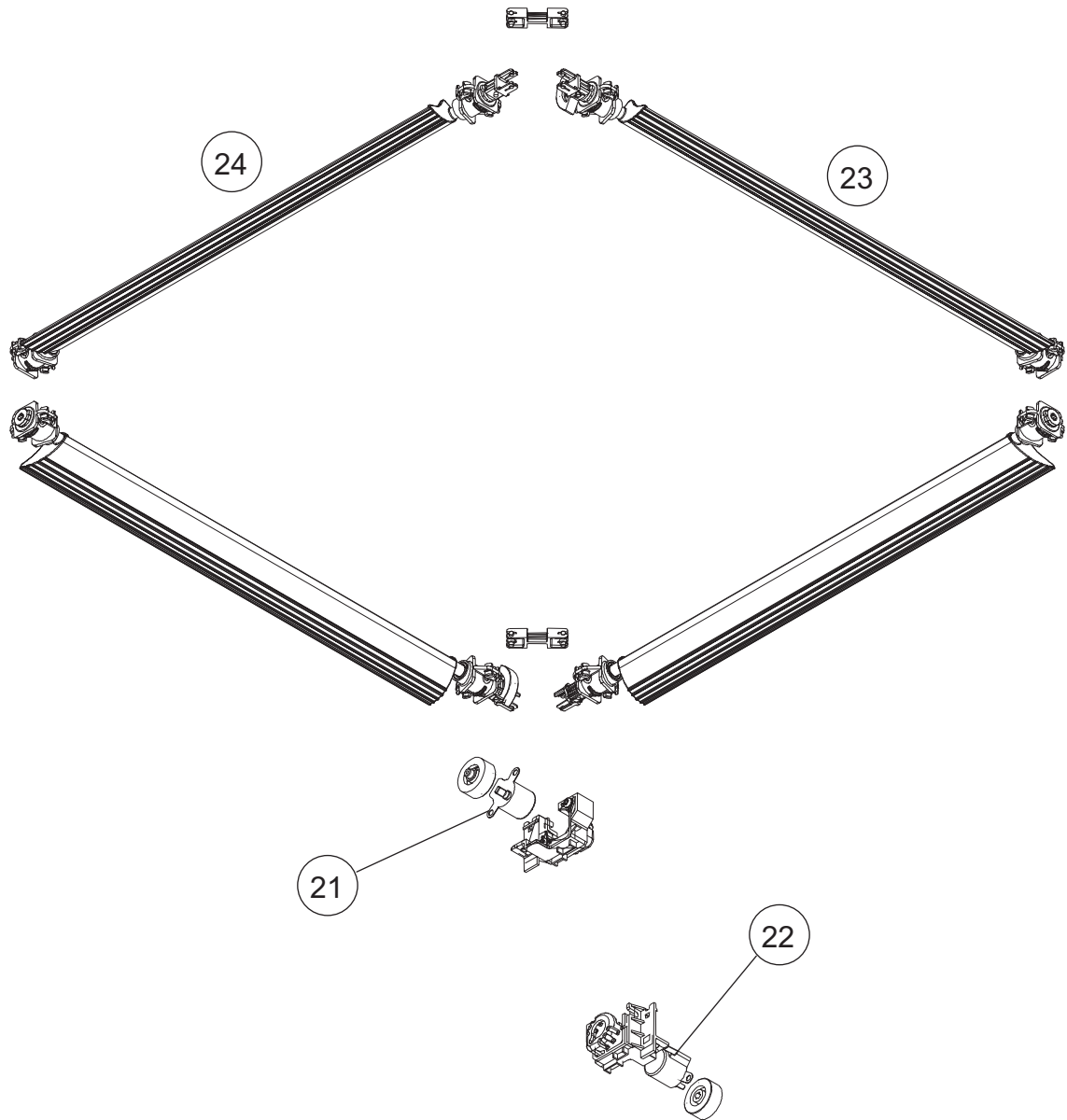

Ref	Description	Parts No.
21	Step Motor (White connector)	9900139070
22	Step Motor (Red connector)	9900139087
23	Flap assy A	9375727048
24	Flap assy B	9377759047



### 3. Indoor unit parts list

#### 3-1. Models: AUXG18KVLA, AUXG22KVLA, and AUXG24KVLA

TECHNICAL DATA  
AND PARTS LIST

TECHNICAL DATA  
AND PARTS LIST

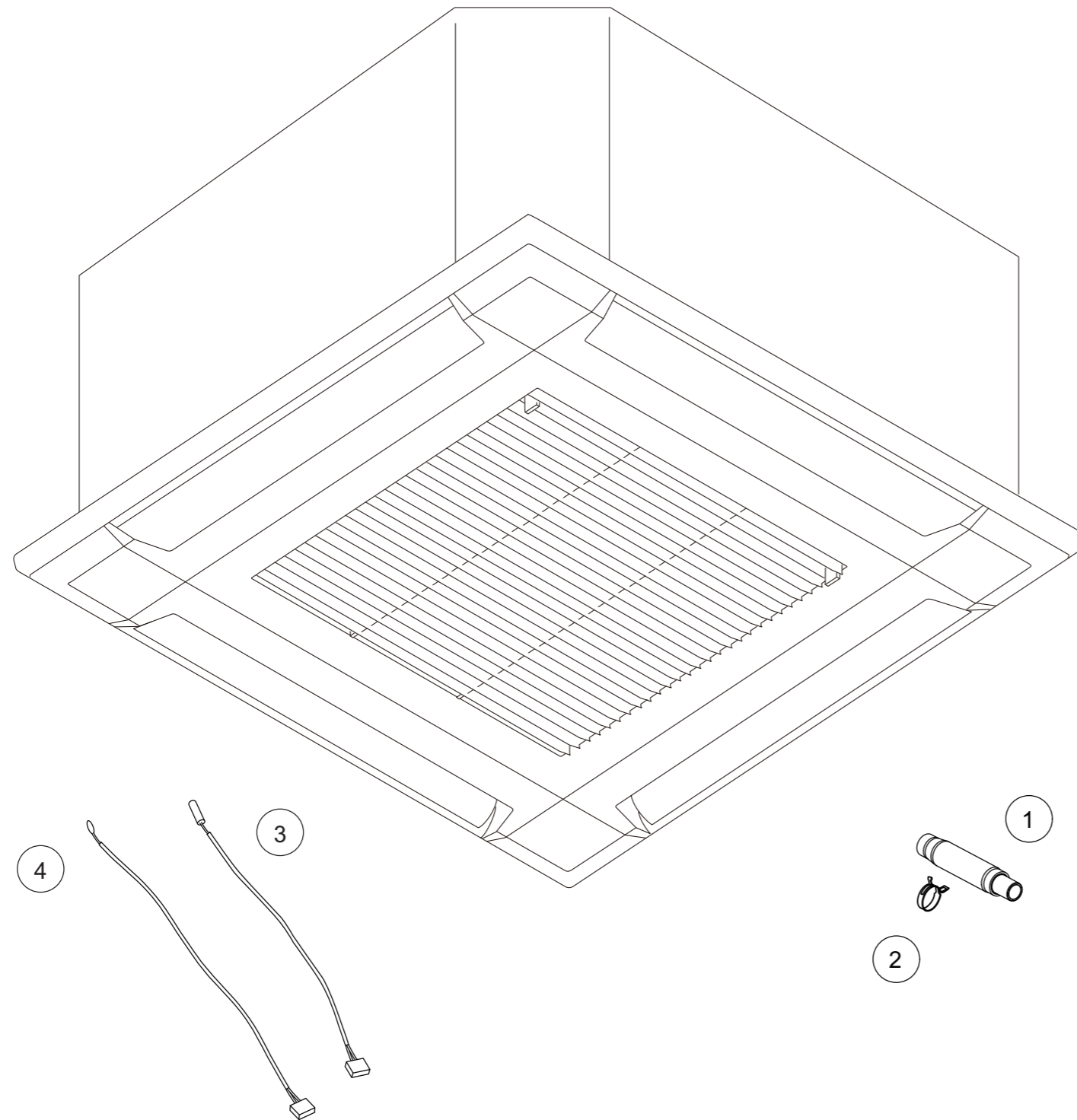

Ref.	Description	Part number
1	Drain hose	9379665001
2	Hose band	9379757010
3	Pipe Thermistor	9900942038
4	Room Thermistor	9900826000

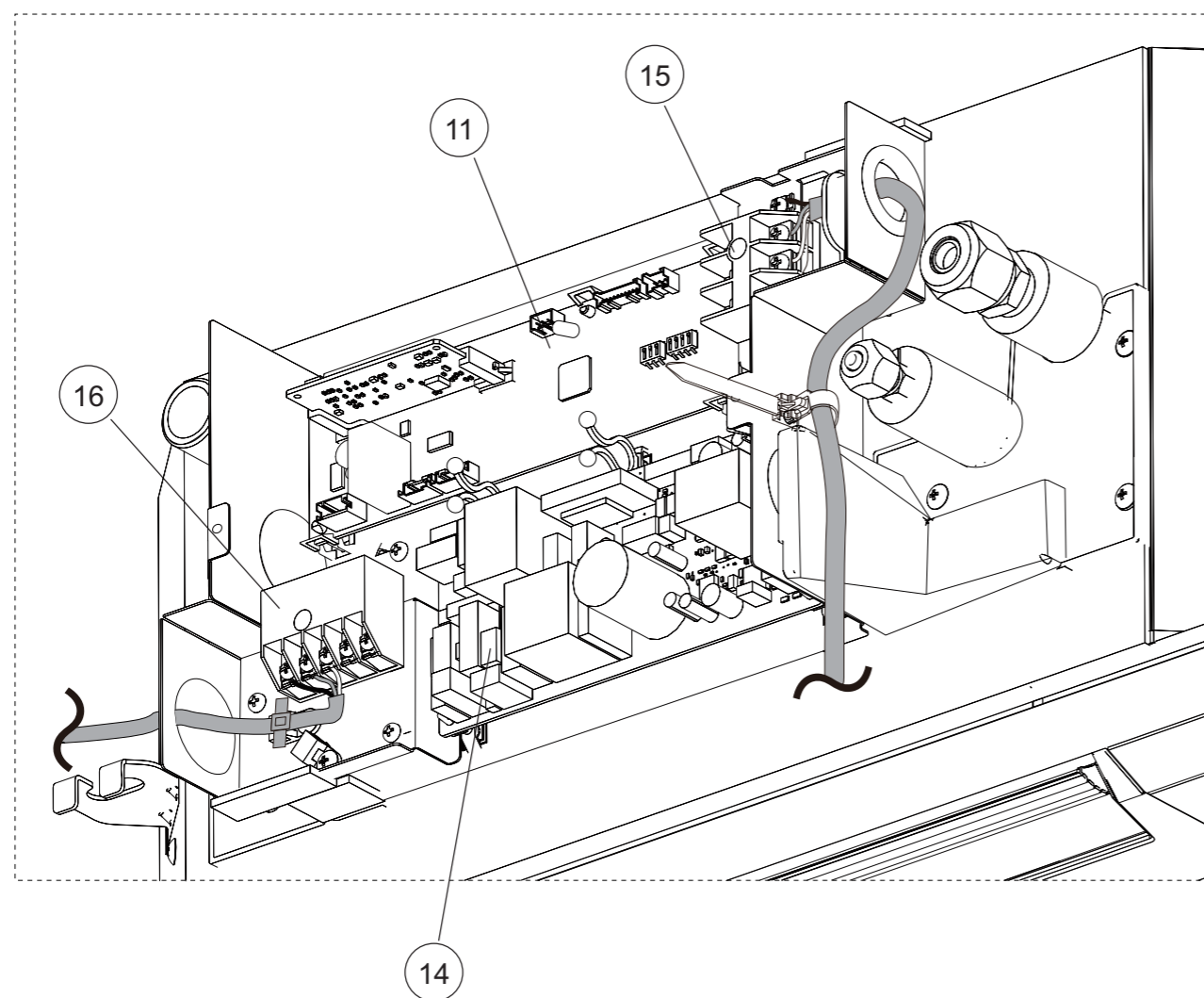
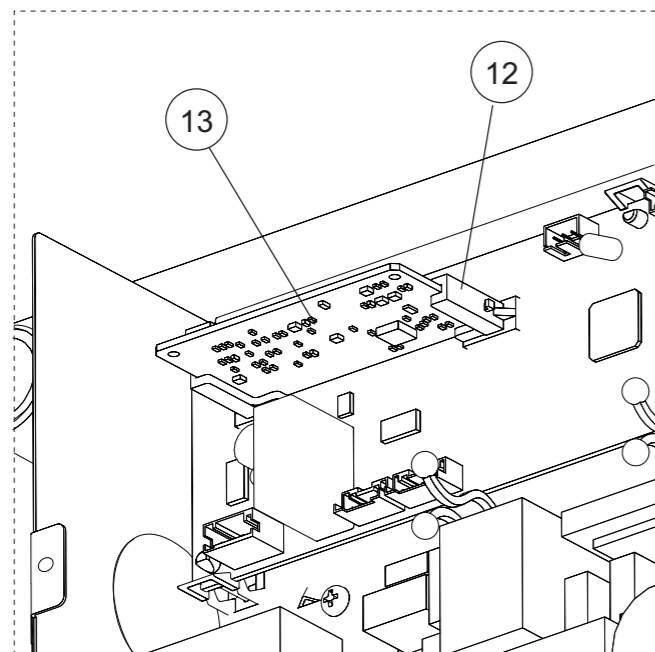

Ref.	Description	Part number
11	Main PCB (07)	9710995965
11	Main PCB (09)	9710995743
11	Main PCB (12)	9710995750
11	Main PCB (14)	9710995705
11	Main PCB (18)	9710995767
11	Main PCB (22)	9710995613
11	Main PCB (24)	9710995866
12	Holder	0600063023
13	Communication PCB	9710019005
14	Power supply PCB	9710661006
15	Terminal	9900568009
16	Terminal	9900896003

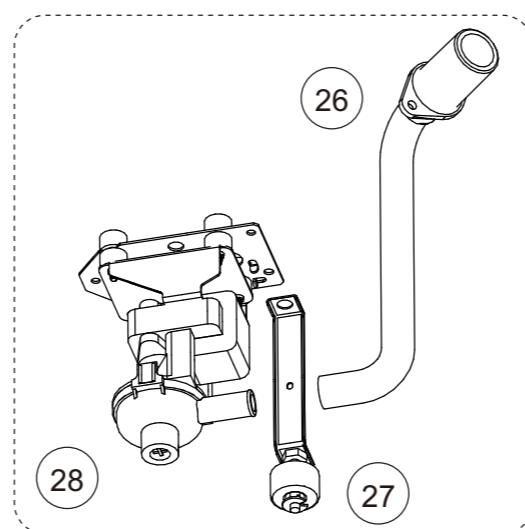
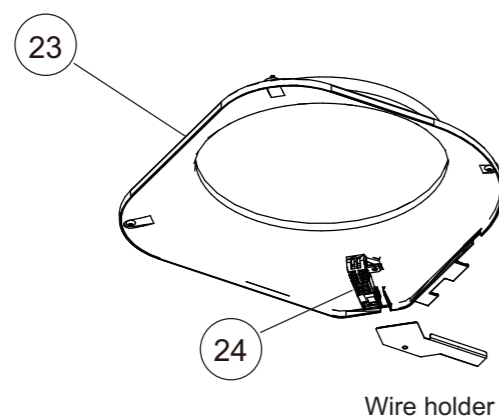
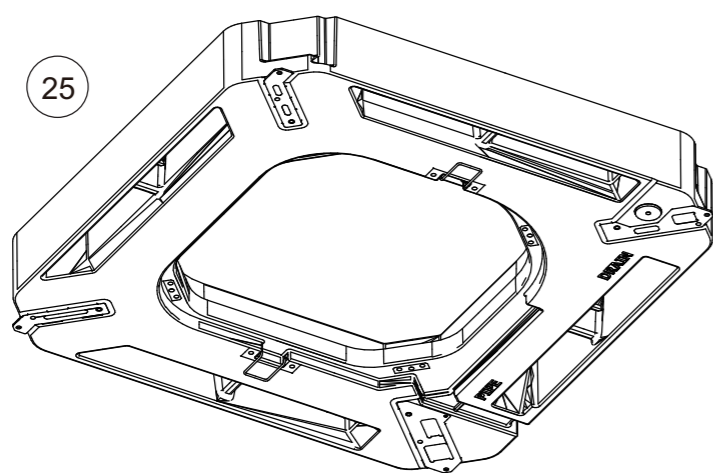
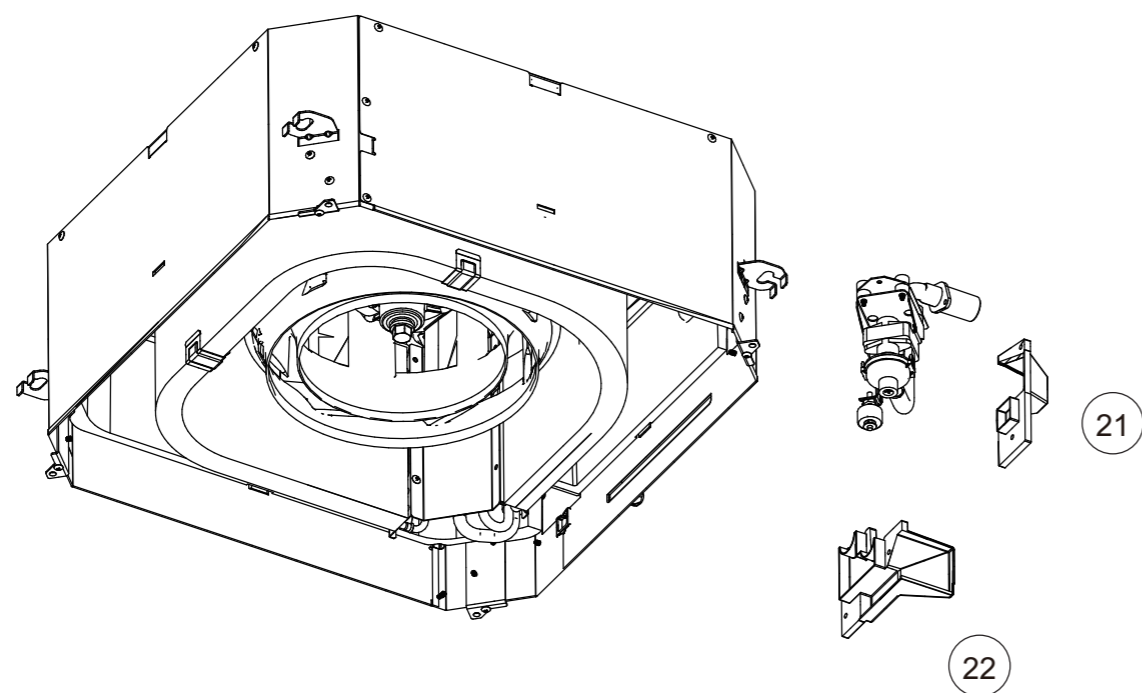

Ref.	Description	Part number
21	Wire cover	9375516017
22	Pipe cover	9375515010
23	Bellmouth	9375503017
24	Thermistor holder	9375477011
25	Drain pan sub assy (18)	9377765024
25	Drain pan sub assy (22, 24)	9377765017
26	Drain port sub assy	9375718015
27	Float Switch sub assy	9375721046
28	Drain pump sub assy	9375717025



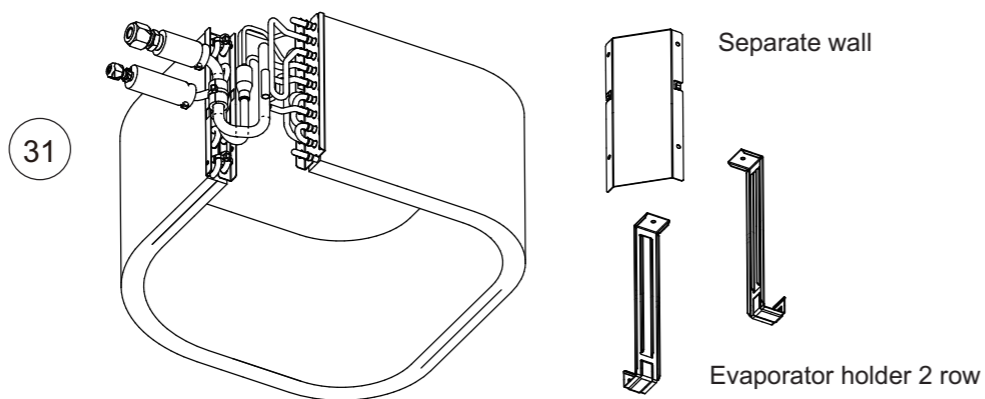
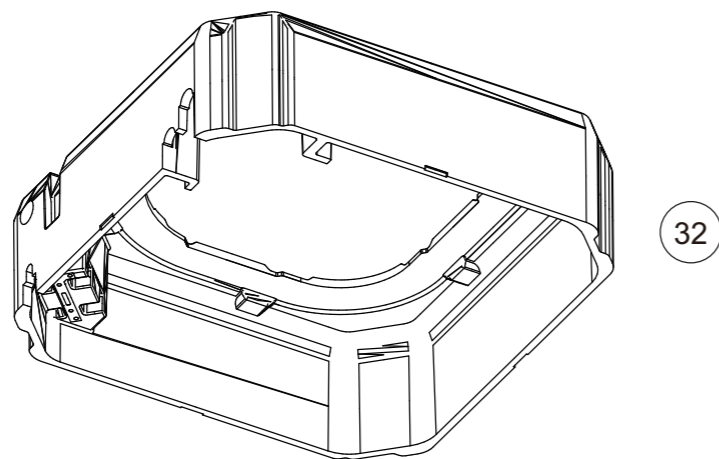
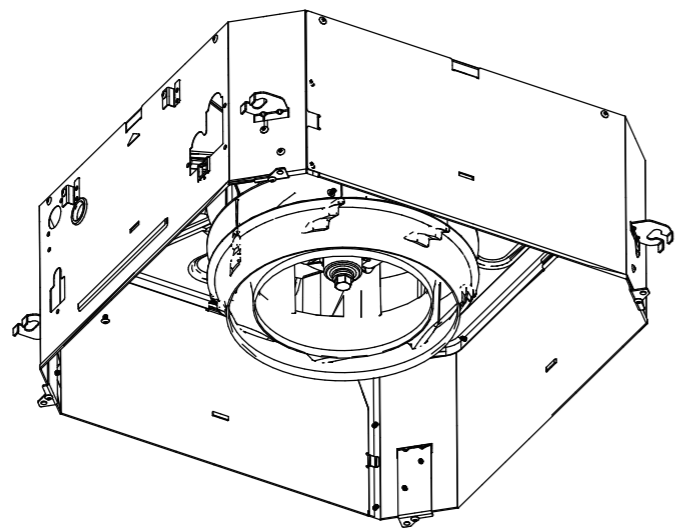

Ref.	Description	Part number
31	Evaporator total assy (07)	9377914156
31	Evaporator total assy (09, 12)	9377914101
31	Evaporator total assy (14)	9377914118
31	Evaporator total assy (18)	9377914125
31	Evaporator total assy (22, 24)	9377914149
32	Insulation box sub assy (07-18)	9377764065
32	Insulation box sub assy (22, 24)	9377764058

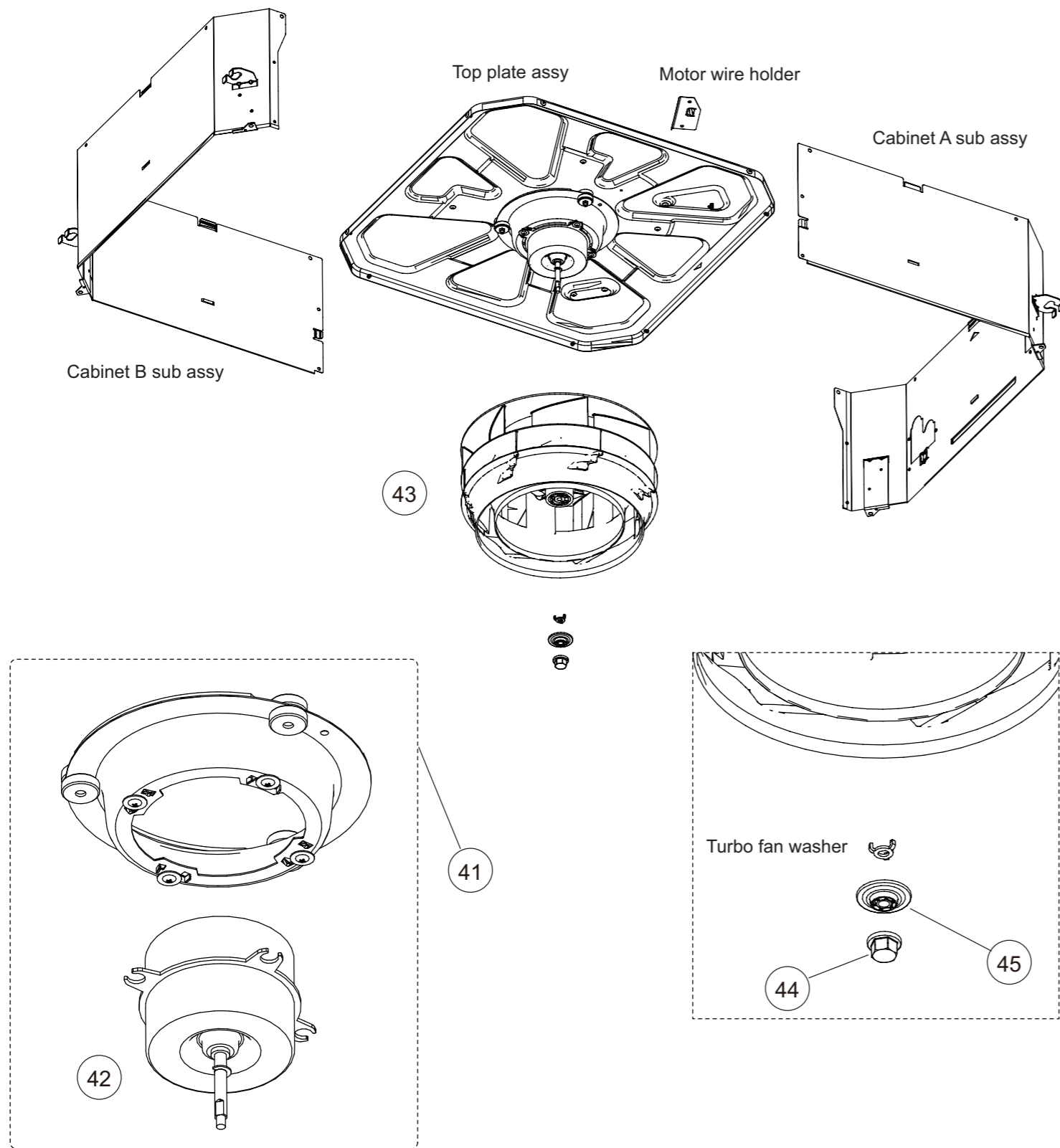

Ref.	Description	Part number
41	Fan motor sub assy	9375719012
42	Fan motor	9602436019
43	2 stage turbo fan assy	9375480011
44	Shaft cap	9377807014
45	Washer cover	9377811011

## 3-2. Model: ARXG18KLLAP

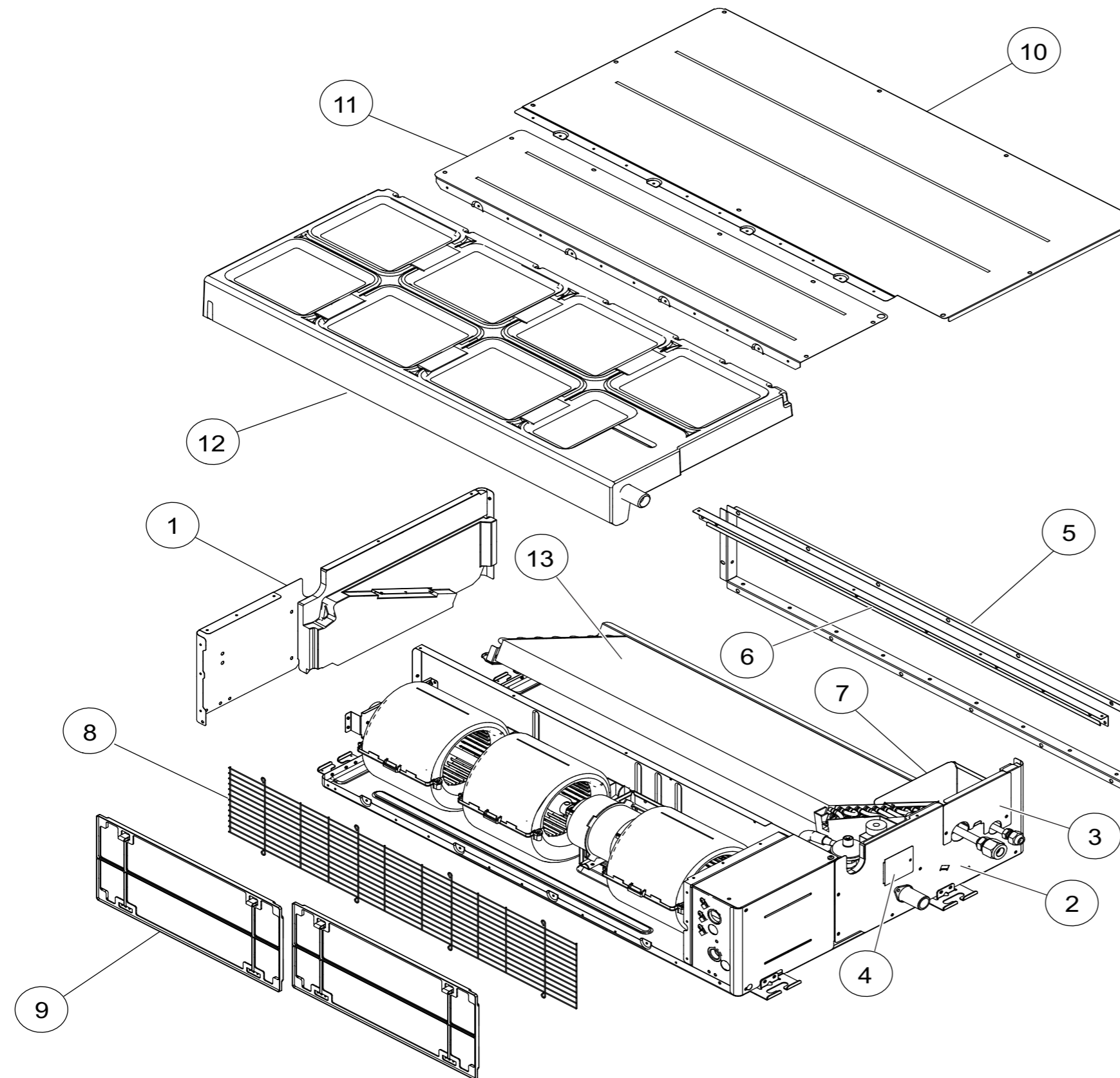

Ref	Description	Parts number
1	Side Panel R Sub Assy	9379906012
2	Side Panel L Sub Assy	9379907019
3	Pipe Panel Sub Assy	9379900003
4	Panel (Window) Sub Assy	9379915007
5	Outlet Frame Assy	9380042013
6	Front Panel (3 Fan)	9380595007
7	Valve Cover Sub Assy	9379576017
8	Fan Guard (3 Fan)	9380590002
9	Air Filter	9379575003
10	Main Panel (3 Fan)	9380603016
11	Cabinet Panel (3 Fan)	9380598008
12	Drain Pan Sub Assy	9379901178
13	Evaporator Total Assy (18)	9380682493

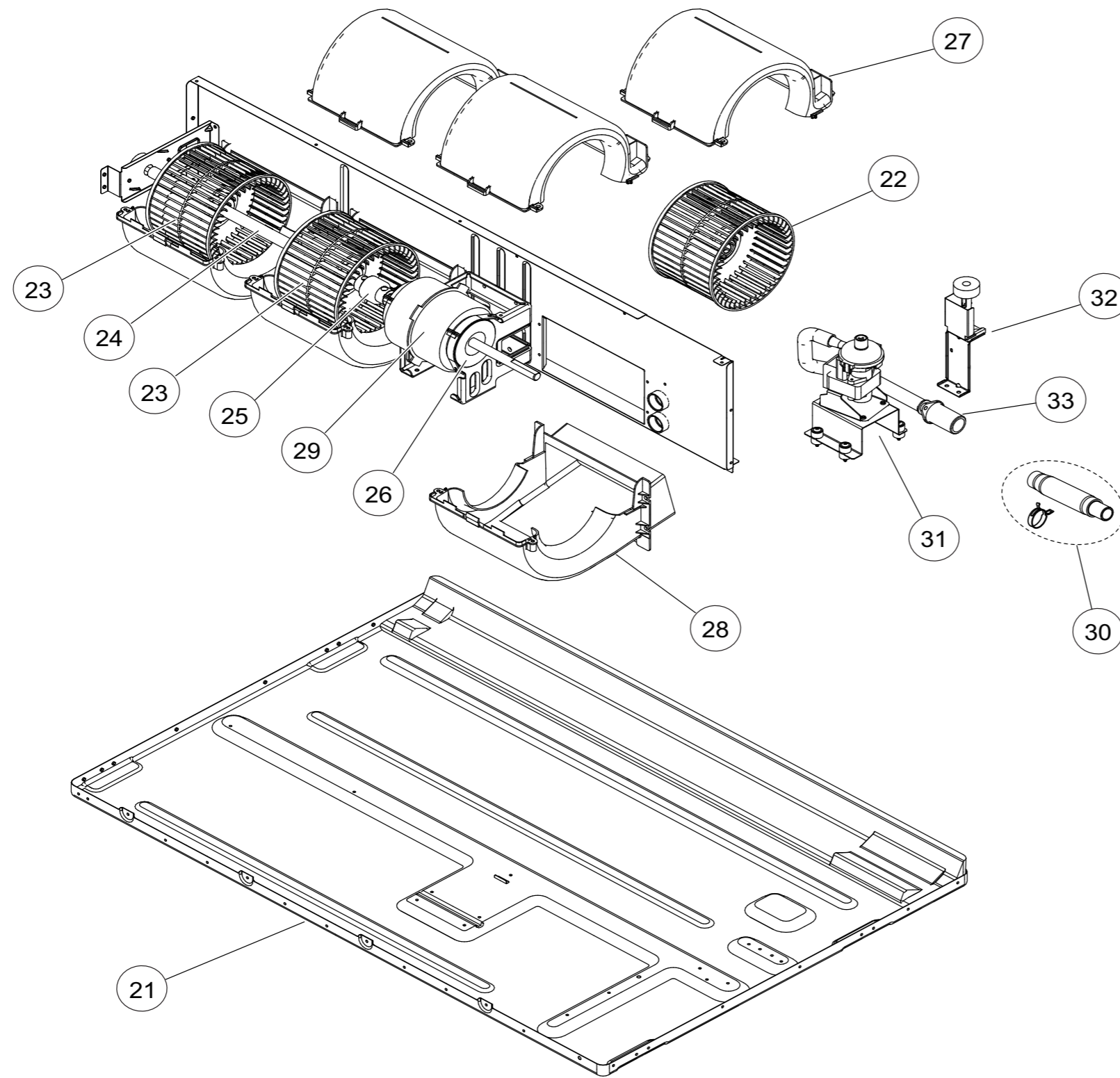

Ref	Description	Parts number
21	Top Panel Sub Assy	9379908047
22	Sirroco Fan Assy	9379570022
23	Sirroco Fan Assy	9379570039
24	Shaft assy	9381052004
25	Joint Assy	9378038011
26	Rubber (Vibration Proof)	9379644006
27	Casing B	9379572019
28	Casing U	9379571012
29	Fan Motor Assy	9379047142
30	Hose Sub Assy	9378450097
31	Drain Pump Sub Assy	9379914062
32	Float Switch Sub Assy	9378593039
33	Drain Hose Assy	9379913003

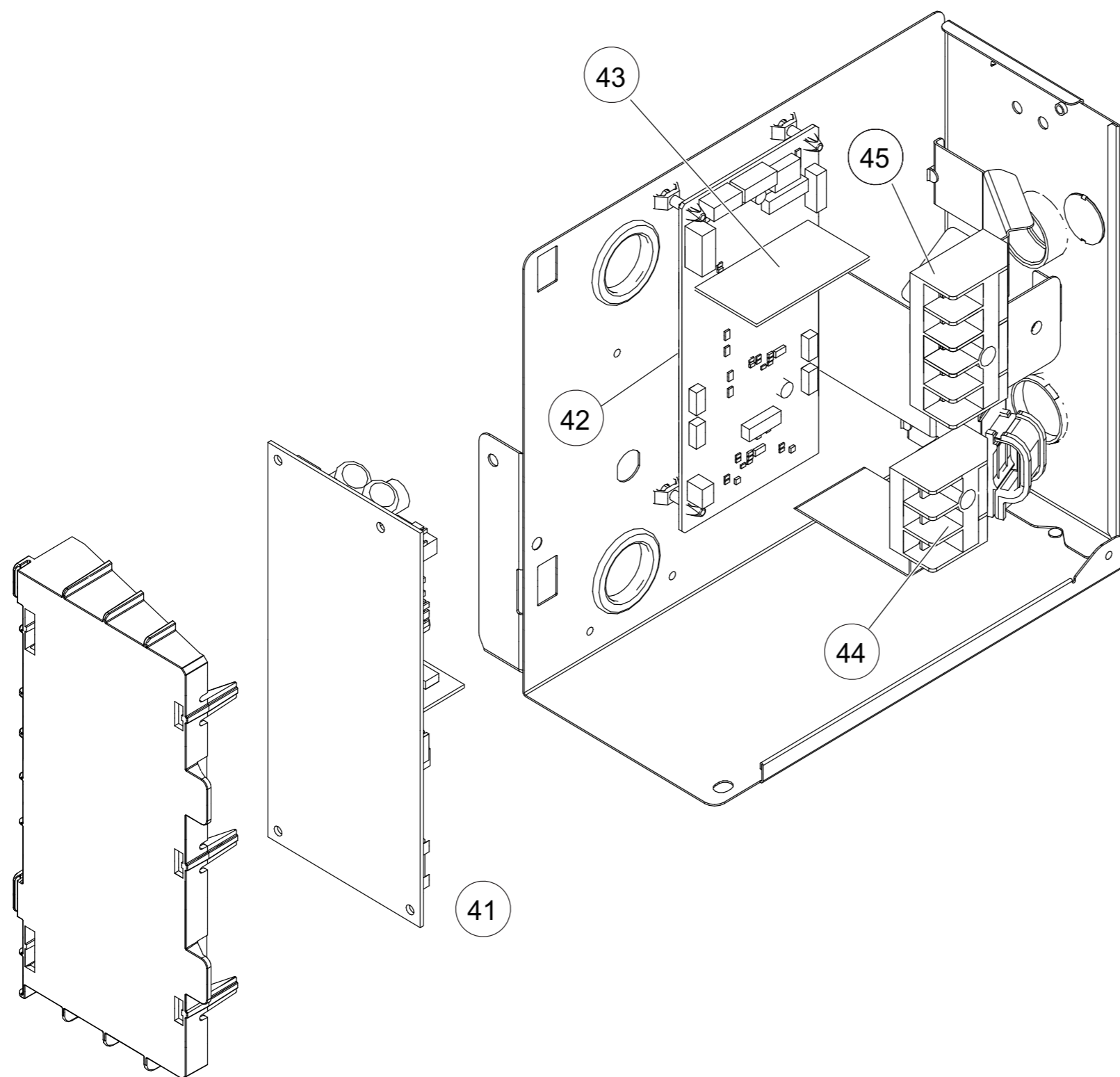

Ref	Description	Parts number
41	Power Supply PCB	9710661006
42	Main PCB	9710624131
43	2 way Remote PCB	9710019005
44	Terminal 3P	9900568009
45	Terminal 3P (Wired Remote)	9900896003
--	Room Thermistor	9900653019
--	Pipe Thermistor	9900942045

### 3-3. Models: ARXG22KMLA and ARXG24KMLA

Hook metal

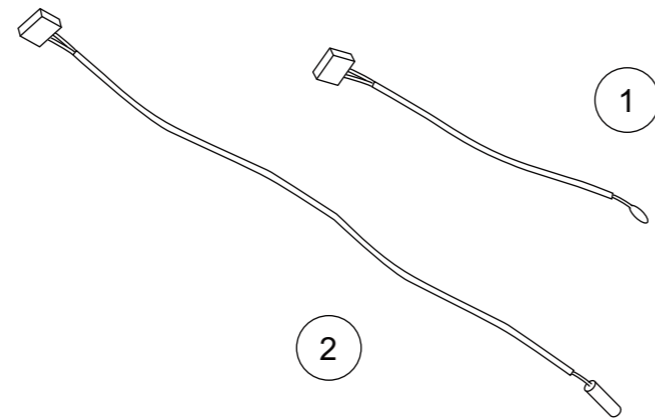
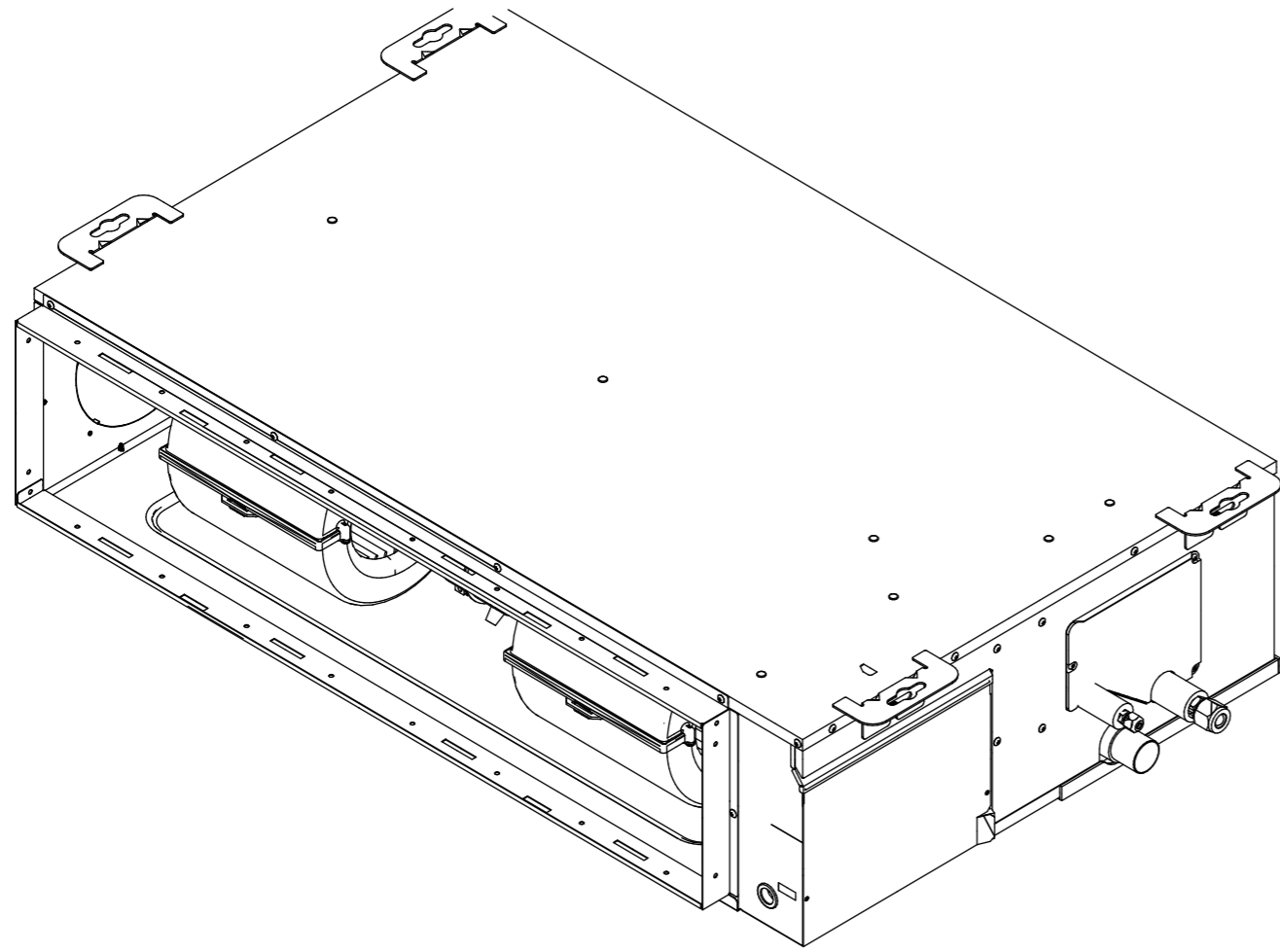

Ref.	Description	Part number
1	Room thermistor	9900826048
2	Pipe thermistor	9900942045

TECHNICAL DATA  
AND PARTS LIST

TECHNICAL DATA  
AND PARTS LIST

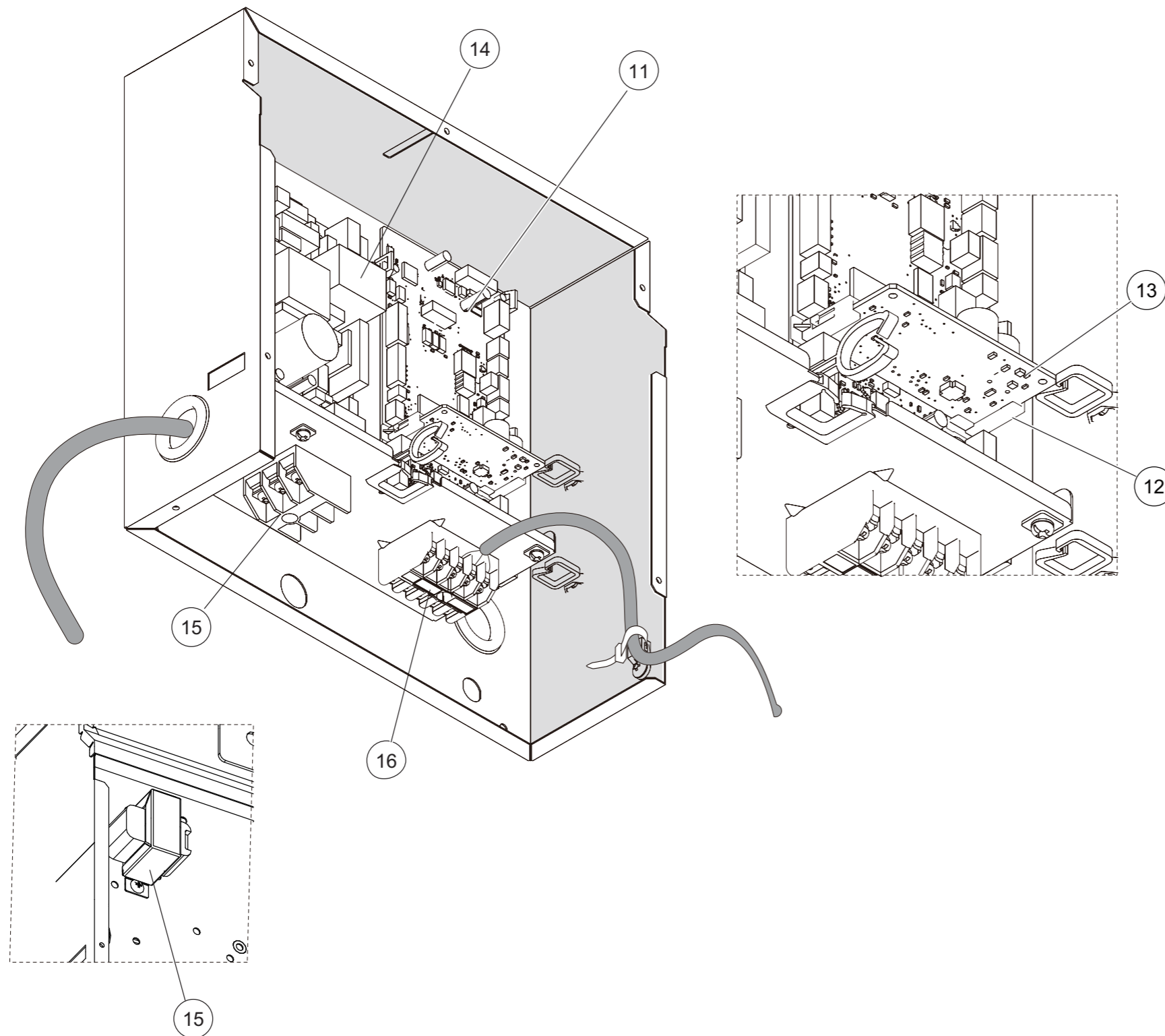

Ref.	Description	Part number
11	Main PCB (22)	9710624124
11	Main PCB (24)	9710624223
12	Holder	0600063023
13	Communication PCB	9710019005
14	Power supply PCB	9710661013
15	Terminal 3P	9306489045
16	Terminal 5P	9900896003
17	Reactor assy	9707457049

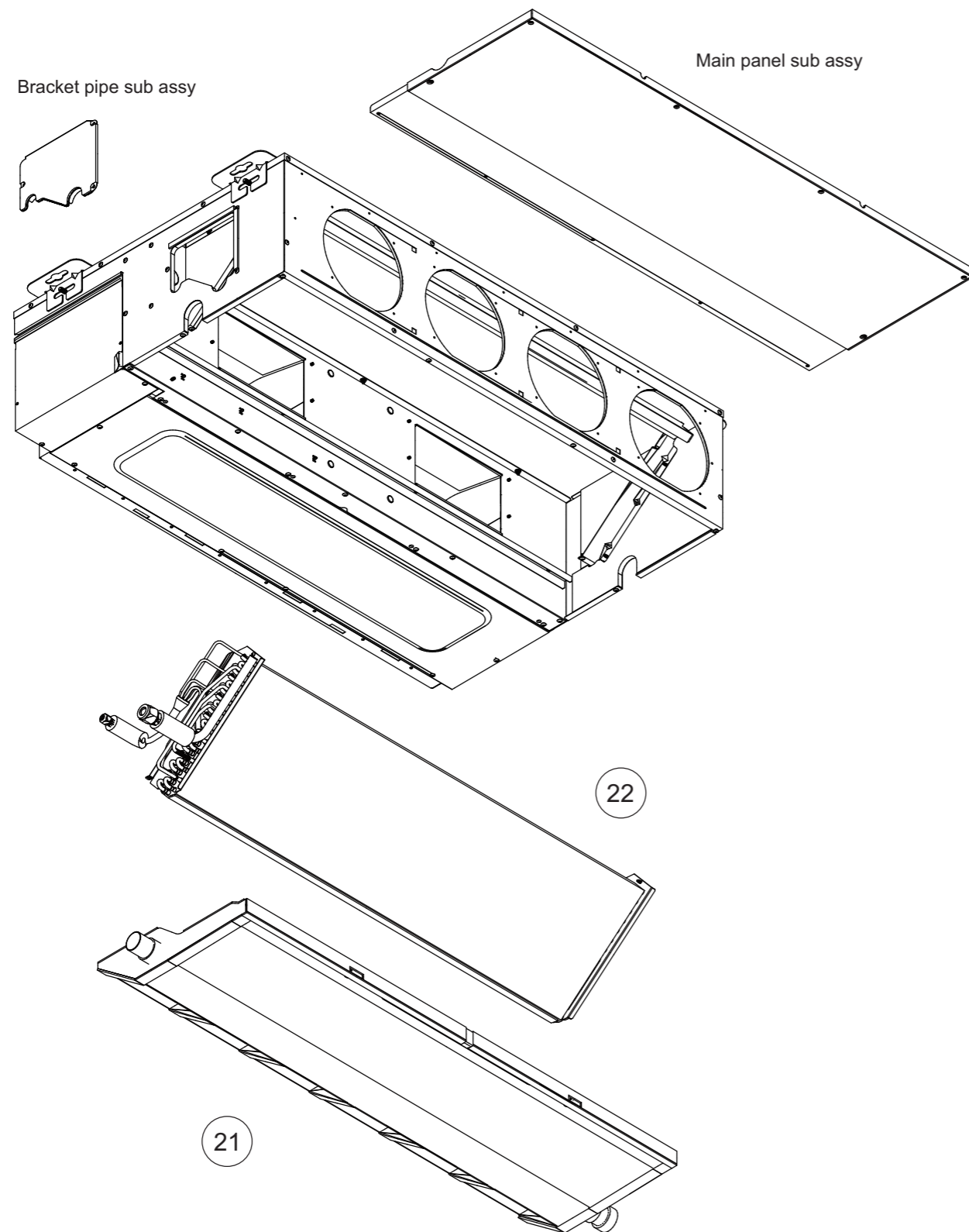

Ref.	Description	Part number
21	Drain pan sub assy	9374513017
22	Evaporator Total Assy	9374517978



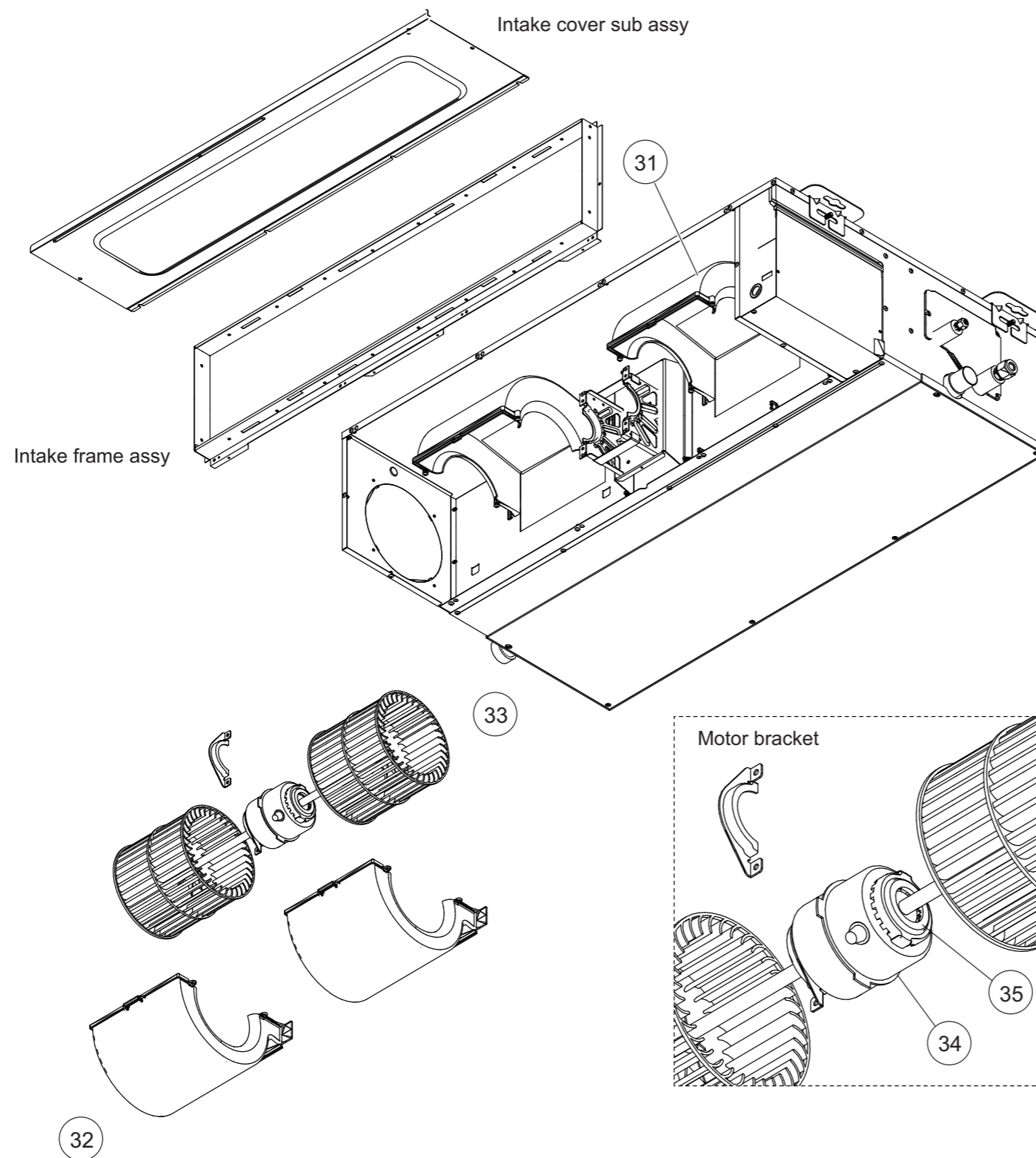

Ref.	Description	Part number
31	Casing A	9374233021
32	Casing B	9374234028
33	Sirocco fan Assy	9356531060
34	Fan motor Assy	9380718031
35	Rubber	9385102002

# 4. Outdoor unit parts list

## 4-1. Model: AOYG36KRTA

### ■ Exterior parts and chassis

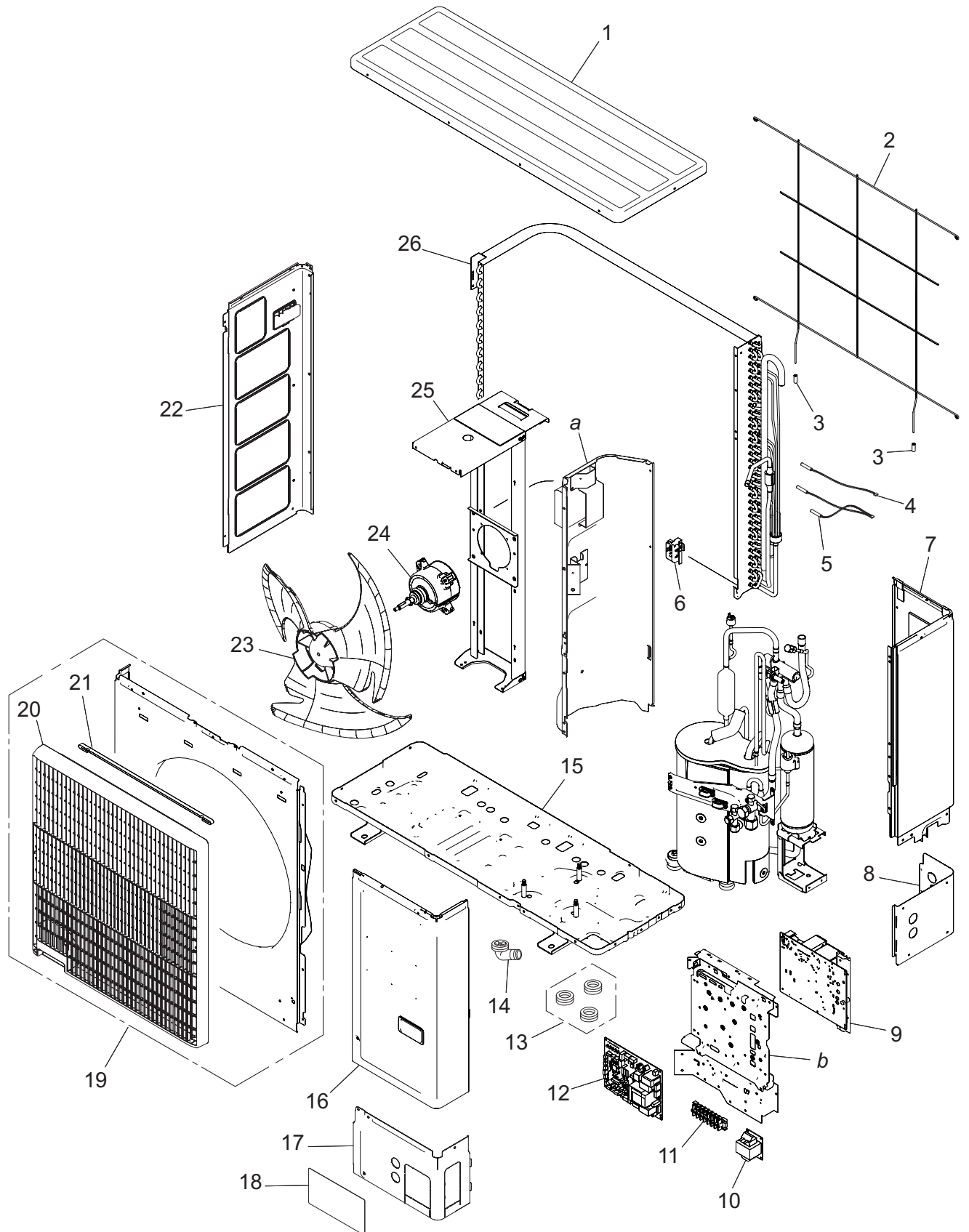

TECHNICAL DATA  
AND PARTS LIST

TECHNICAL DATA  
AND PARTS LIST

Item no.	Part no.	Part name	Service part
1	9383880001	Top panel assy	◆
2	9383779008	Protective net	◆
3	9375361013	Net rubber	◆
4	9900984038	Thermistor (Heat exchanger)	◆
5	9900727154	Thermistor assy	◆
6	9383607004	Thermo holder	◆
7	9383874000	Right panel sub assy	◆
8	9383879005	Rear pipe cover	◆
9	9711424006	Inverter PCB	◆
10	9900634025	Reactor assy	◆
11	9901053016	Terminal	◆
12	9711431080	Main PCB (Service)	◆
13	313166024302	Drain cap	◆
14	9303029015	Drain assy	◆
15	9383871009	Base assy	◆
16	9383876004	Service panel sub assy	◆
17	9383878008	Front pipe cover	◆
18	9351355005	Emblem rear	◆
19	9383863004	Front panel assy	◆
20	9383604003	Blow grille	◆
21	9383689000	Blow grille insulation	◆
22	9383882005	Left panel sub assy	◆
23	9383336003	Propeller fan	◆
24	9603732011	Brushless motor	◆
25	9383862007	Motor bracket assy	◆
26	9374420612	Condenser sub assy	◆
<i>a</i>	—	Separate wall assy	—
<i>b</i>	—	Control box unit	—

# Compressor

TECHNICAL DATA  
AND PARTS LIST

TECHNICAL DATA  
AND PARTS LIST

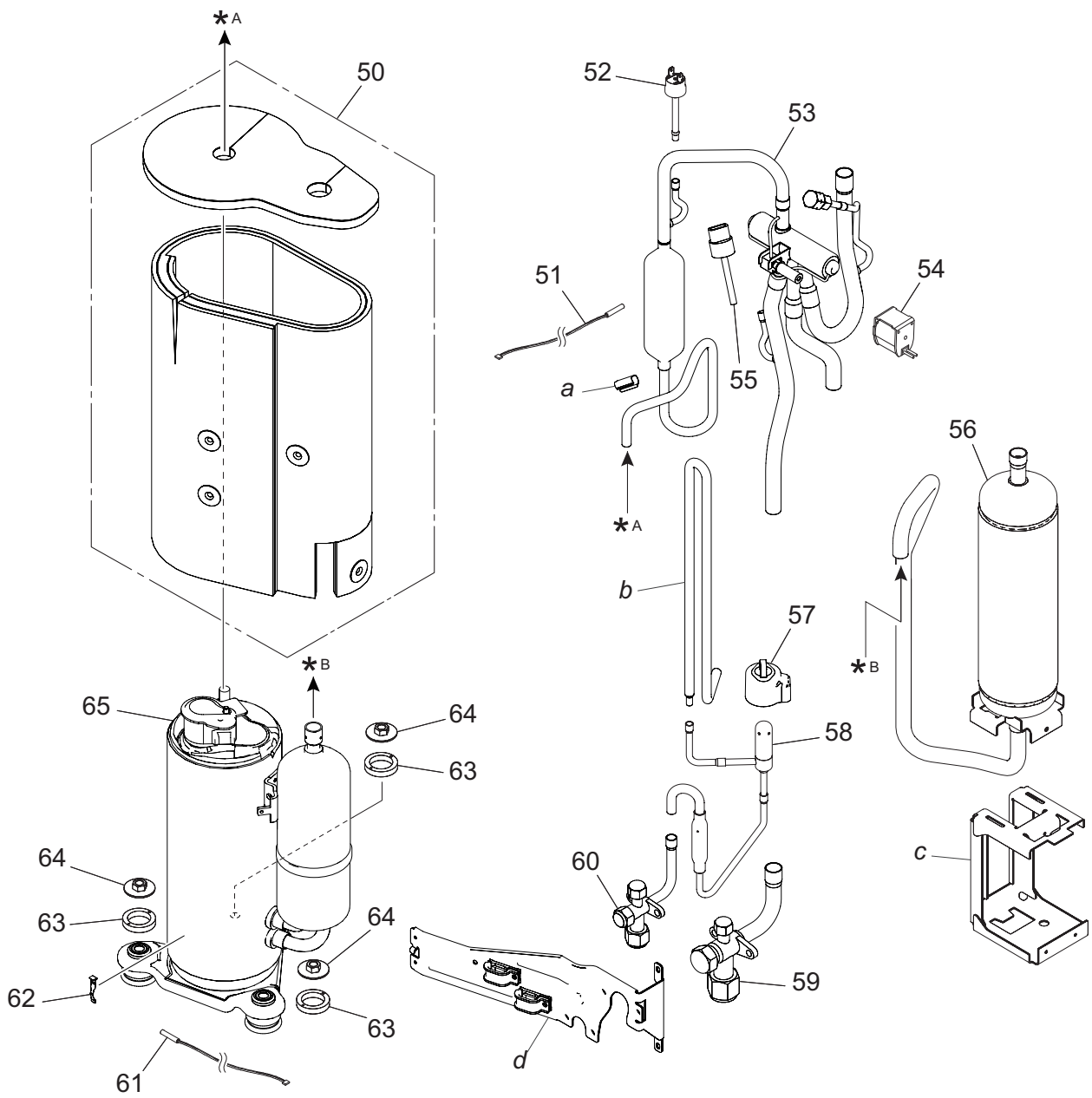

Item no.	Part no.	Part name	Service part
50	9383858000	Sound insulation unit	◆
51	9900565091	Thermistor (Outdoor temp.)	◆
52	9900186029	Pressure switch	◆
53	9374425631	4-way valve assy	◆
54	9970194016	Solenoid	◆
55	9970158018	Sensor	◆
56	9375250140	Accumulator assy	◆
57	9970209000	Expansion valve coil	◆
58	9370947328	Expansion valve assy	◆
59	9379079013	3-way valve assy	◆
60	9377958037	3-way valve assy	◆
61	9900985035	Thermistor (Compressor)	◆
62	9810028006	Thermistor stopper	◆
63	9379179065	Rubber washer C	◆
64	9377973016	Special nut	◆
65	9383821011	Compressor assy	◆
<i>a</i>	—	Thermostat holder	—
<i>b</i>	—	Joint pipe D	—
<i>c</i>	—	Accumulator holder A	—
<i>d</i>	—	Wiring fixation unit	—

# 4-2. Models: AOYG45KRTA and AOYG54KRTA

## ■ Exterior parts and chassis

TECHNICAL DATA  
AND PARTS LIST

TECHNICAL DATA  
AND PARTS LIST

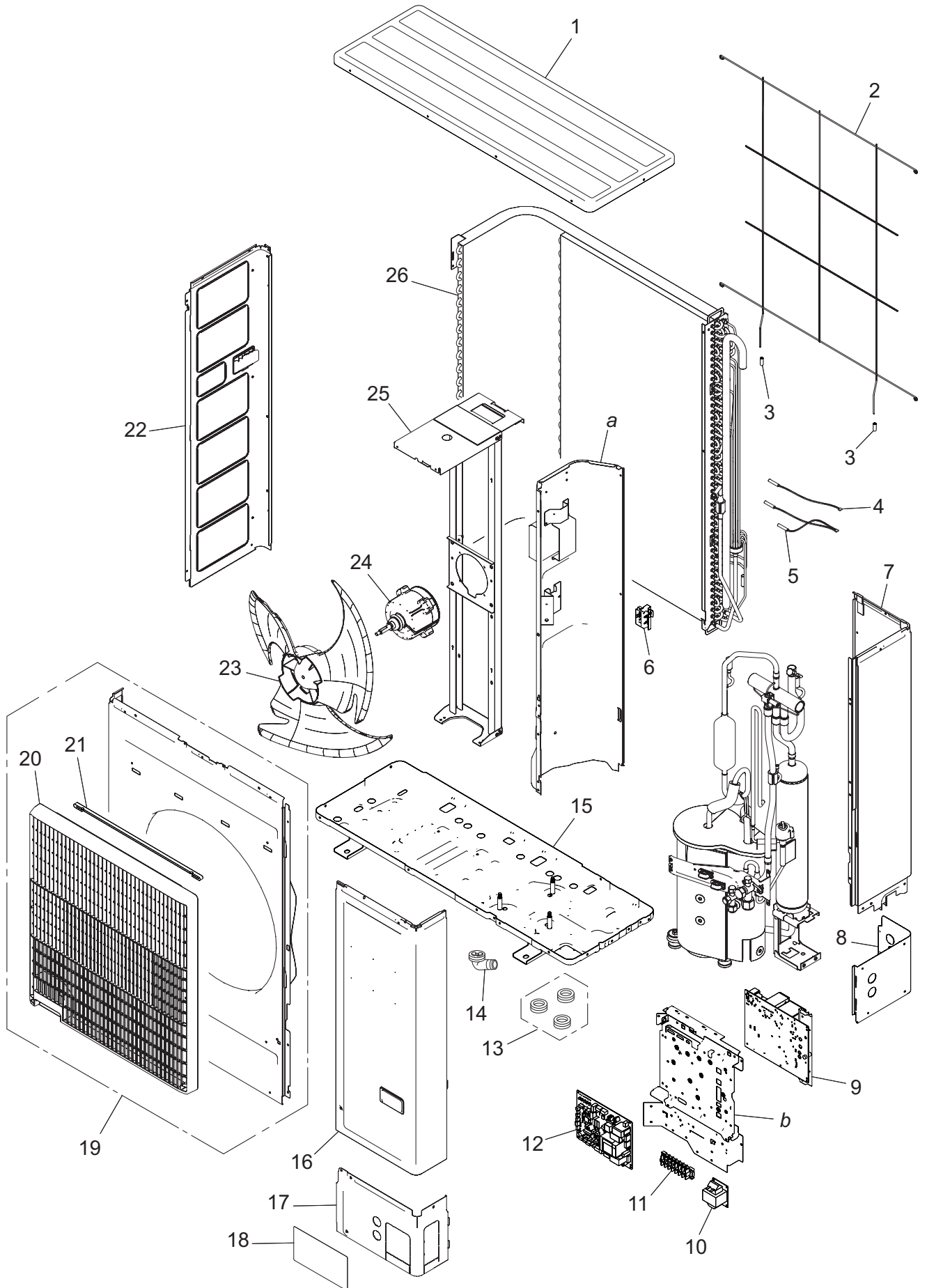

Item no.	Part no.	Part name	Service part
1	9383880001	Top panel assy	◆
2	9381013005	Protective net	◆
3	9375361013	Net rubber	◆
4	9900984038	Thermistor (Heat exchanger)	◆
5	9900727154	Thermistor assy	◆
6	9383607004	Thermo holder	◆
7	9383874017	Right panel sub assy	◆
8	9383879005	Rear pipe cover	◆
9	9711424013	Inverter PCB	◆
10	9900634025	Reactor assy	◆
11	9901053016	Terminal	◆
12	9711431097	Main PCB (Service) (for 45 model)	◆
	9711431103	Main PCB (Service) (for 54 model)	◆
13	313166024302	Drain cap	◆
14	9303029015	Drain assy	◆
15	9383871009	Base assy	◆
16	9383876011	Service panel sub assy	◆
17	9383878008	Front pipe cover	◆
18	9351355005	Emblem rear	◆
19	9383863011	Front panel assy	◆
20	9383604003	Blow grille	◆
21	9383689000	Blow grille insulation	◆
22	9383882012	Left panel sub assy	◆
23	9383336003	Propeller fan	◆
24	9603733018	Brushless motor	◆
25	9383862014	Motor bracket assy	◆
26	9374420605	Condenser sub assy	◆
<i>a</i>	—	Separate wall assy	—
<i>b</i>	—	Control box unit	—

# Compressor

TECHNICAL DATA  
AND PARTS LIST

TECHNICAL DATA  
AND PARTS LIST

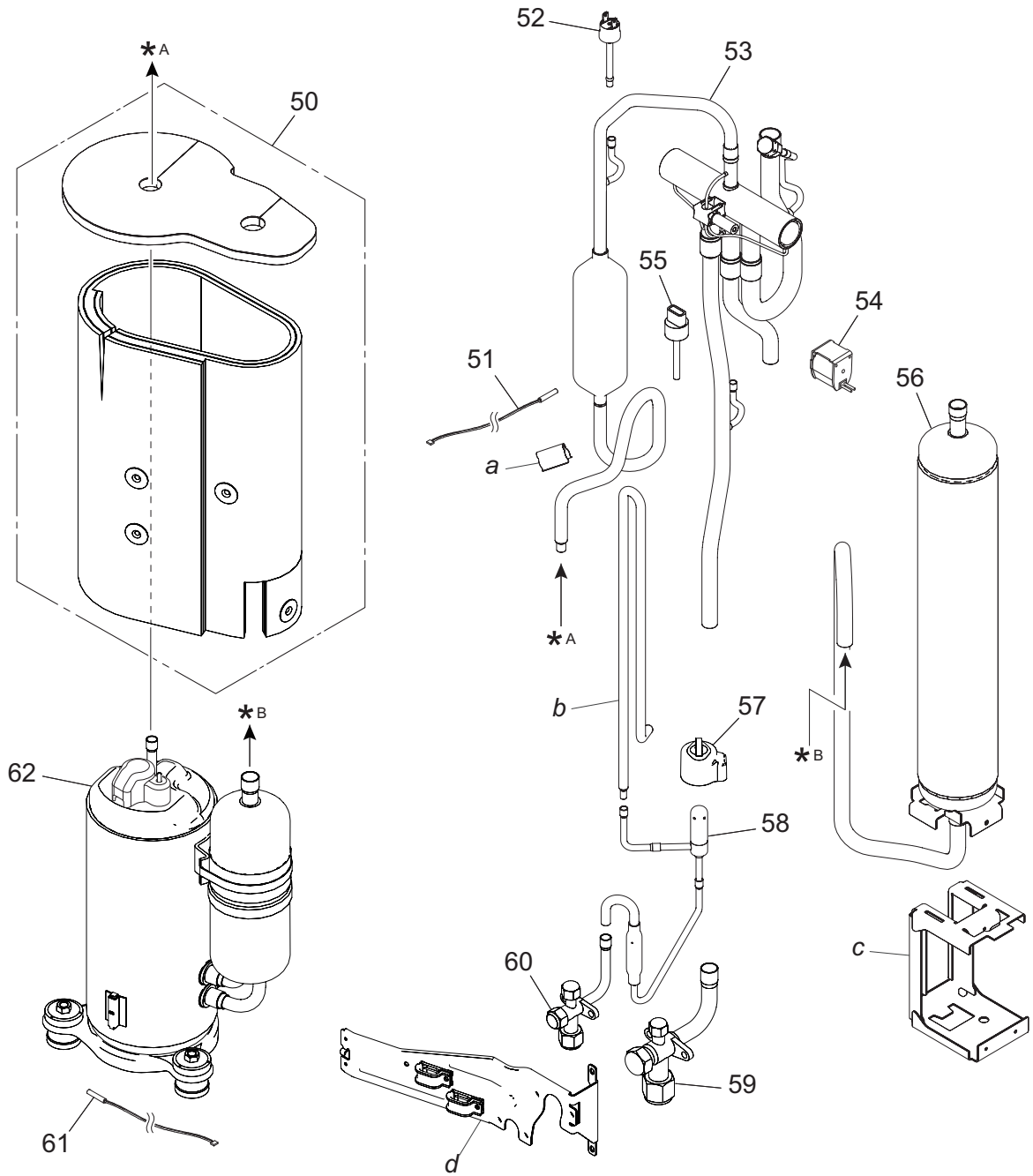









Item no.	Part no.	Part name	Service part
50	9383858017	Sound insulation unit	◆
51	9900565091	Thermistor (Outdoor temp.)	◆
52	9900186029	Pressure switch	◆
53	9374425624	4-way valve assy	◆
54	9970194016	Solenoid	◆
55	9970158018	Sensor	◆
56	9375250133	Accumulator assy	◆
57	9970209000	Expansion valve coil	◆
58	9370947311	Expansion valve assy	◆
59	9379079013	3-way valve assy	◆
60	9377958037	3-way valve assy	◆
61	9900985028	Thermistor (Compressor)	◆
62	9383851025	Compressor unit	◆
<i>a</i>	—	Thermistor spring	—
<i>b</i>	—	Joint pipe D	—
<i>c</i>	—	Accumulator holder A	—
<i>d</i>	—	Wiring fixation unit	—

## 5. Accessories

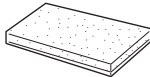
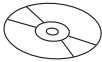
### 5-1. Indoor unit

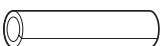
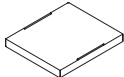
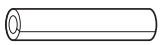



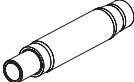



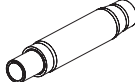

#### ■ Compact cassette type

#### ● Models: AUXG18KVLA, AUXG22KVLA, and AUXG24KVLA

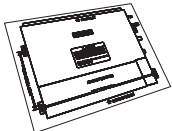
Part name	Exterior	Q'ty	Part name	Exterior	Q'ty
Operating manual		1	Drain hose insulation		1
Operating manual (CD-ROM)		1	Hose band		1
Installation manual		1	Coupler heat insulation (large)		1
Template (Carton top)		1	Coupler heat insulation (small)		1
M10 nut A (with flange)		4	Cable tie		2
M10 nut B (with spring lock washer)		4	Wire crammer		1
Drain hose		1			



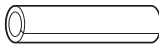

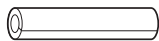





## ■ Slim duct type

### ● Model: ARXG18KLLAP

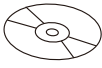
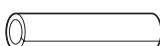
Part name	Exterior	Q'ty	Part name	Exterior	Q'ty
Operating manual		1	Filter (large)		2
Operating manual (CD-ROM)		1	Drain hose		1
Installation manual		1	Hose band		1
Installation template		1	Drain hose insulation B		1
Washer		8	Insulation (for electrical wiring)		2
Cable tie (large)		4	Coupler heat insulation (large)		1
Cable tie (medium)		3	Coupler heat insulation (small)		1

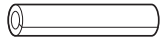
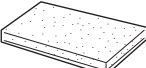



## ■ Duct type

### ● Models: ARXG22KMLA and ARXG24KMLA

Part name	Exterior	Q'ty	Part name	Exterior	Q'ty
Operating manual		1	Cable tie (Small)		1
Installation manual		1	Cable tie		1
CD-ROM		1	Coupler heat insulation (Large)		1
Hanger		4	Coupler heat insulation (Small)		1
Drain hose insulation		1	M10 nut A (with flange)		4
Cable tie (Large)		1	M10 nut B (with spring lock washer)		4

## 5-2. Outdoor unit

### ■ Models: AOYG36KRTA, AOYG45KRTA, and AOYG54KRTA

Part name	Exterior	Q'ty	Part name	Exterior	Q'ty
Installation manual		1	Drain cap		3
Drain pipe		1	One-touch bush		2

## 6. Optional parts

### 6-1. Branch pipes

#### ■ Model: UTP-SX236A

Unit: mm

Port diameters			
Liquid pipe	Q'ty	Gas pipe	Q'ty
	1		1

Dimensions	
Liquid pipe	Gas pipe

Heat insulation cover			
Liquid pipe	Q'ty	Gas pipe	Q'ty
	1		1

TECHNICAL DATA  
AND PARTS LIST

TECHNICAL DATA  
AND PARTS LIST

Model: UTP-SX354A

Unit: mm

TECHNICAL DATA  
AND PARTS LIST

TECHNICAL DATA  
AND PARTS LIST

Port diameters			
Liquid pipe	Q'ty	Gas pipe	Q'ty
	1		1

Dimensions	
Liquid pipe	Gas pipe

Heat insulation cover			
Liquid pipe	Q'ty	Gas pipe	Q'ty
	1		1

Others	
Cable tie	Q'ty
	1

## 6-2. Controllers

### Lineup

Indoor unit type	Type		
	Wired remote controller		Simple remote controller
	UTY-RNNYM	UTY-RVNYM	UTY-RSNYM
Compact cassette	○	○	○
Slim duct	○	○	○
Duct	○	○	○



Indoor unit type	Type	
	Wireless remote controller	IR receiver kit with Wireless remote controller
	UTY-LNTY	UTY-LBTYM
Compact cassette	○	—
Slim duct	—	○
Duct	—	○

○: Optional, —: Not applicable

**NOTE:** 2-wire remote controller is not available for this product.

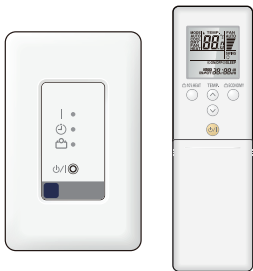
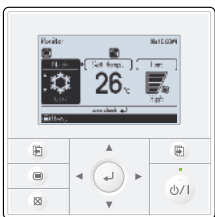
### Parts

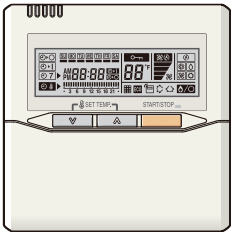
Exterior	Part name	Model name	Summary
	Wireless remote controller	UTY-LNTY	Unit control is performed by wireless remote controller.
	IR receiver kit with wireless remote controller	UTY-LBTYM	Unit control is performed by wireless remote controller.
	Wired remote controller	UTY-RVNYM	Large and full-dot liquid crystal screen, wide and large keys easy to press, user-intuitive arrow key. Wire type: Polar 3-wire

Exterior	Part name	Model name	Summary
	Wired remote controller	UTY-RNNYM	Room temperature can be controlled by detecting the temperature accurately with built-in thermo sensor. Wire type: Polar 3-wire
	Simple remote controller	UTY-RSNYM	Compact remote controller concentrates on the basic functions such as Start/Stop, fan control, temperature setting, and operation mode. Wire type: Polar 3-wire

**NOTE:** Available functions may differ by the remote controller. For details, refer to the operation manual.

## 6-3. Cassette grille

### ■ Parts

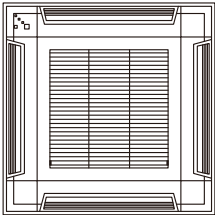
Exterior	Part name	Model name	Summary
	Cassette grille	UTG-UFYF-W	This cassette grille can be installed appropriately on the grid type ceiling common in the office.











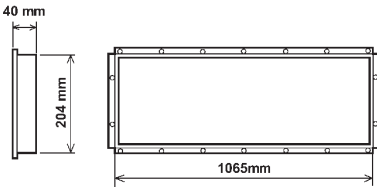
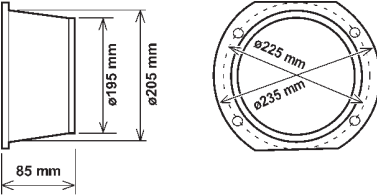
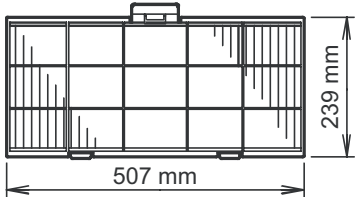

## 6-4. Others

### Lineup

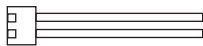
Type	Model	Indoor unit			Outdoor unit
		Compact cassette	Slim duct	Duct	
Air outlet shutter plate	UTR-YDZB	○	—	—	—
Insulation kit for high humidity	UTZ-KXGC	○	—	—	—
Fresh air intake kit	UTZ-VXAA	○	—	—	—
Square flange	UTD-SF045T	—	—	○	—
Round flange	UTD-RF204	—	—	○	—
Long-life filter	UTD-LF25NA	—	—	○	—
Remote sensor unit	UTY-XSZX	—	○	○	—
Auto louver grille kit	UTD-GXTB-W	—	○	—	—
Drain pump unit	UTZ-PX1NBA	—	—	○	—
External connect kit	UTY-XWZXZG	○	○	○	—
	UTY-XWZXZ3	—	—	—	○

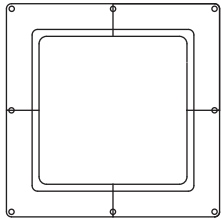
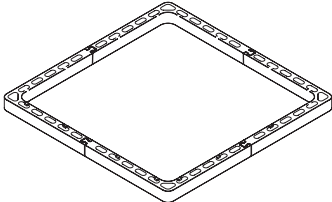
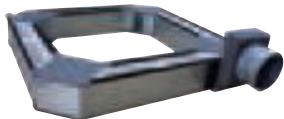
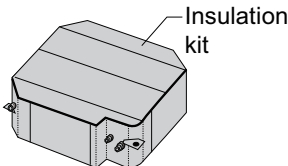
### Parts (for Indoor unit)

Exterior	Part name	Model name	Summary
	Remote sensor unit	UTY-XSZX	Thermo-sensor for sensing the temperature of arbitrary place in the room.
	Auto louver grille kit	UTD-GXSB-W	Width: 883 mm
	Square flange	UTD-SF045T	Both the Square flange and the Round flange can be selected.
	Round flange	UTD-RF204	Round flange is used when the fresh-air duct is installed.
	Long-life filter	UTD-LF25NA	Long-life filter can be mounted to the indoor unit.

Exterior	Part name	Model name	Summary
	Drain pump unit	UTZ-PX1NBA	Optional drain lift up mechanism allows more flexible installation.
	External connect kit	UTY-XWZXZG	Use to connect with various peripheral devices and air conditioner PCB. For control output port.
	Air outlet shutter plate	UTR-YDZC	Installed at the air outlet when 3-directions mode is performed.
	Wide panel	UTG-AKXA-W	Hides the gap between the ceiling hole and the cassette grille.
	Panel spacer	UTG-BGYA-W	If there is not enough height in the ceiling space, by inserting this spacer between the cassette grille and the ceiling surface, the height of the unit body goes into the ceiling space become 50-mm lower.
	Fresh-air intake kit	UTZ-VXAA	By attaching Fresh-air intake kit to the indoor unit, it can be taken in fresh air of up to 10% of "high" air volume of the indoor unit.
	Insulation for high humidity	UTZ-KXGA	Install when the under-roof condition is expected to be the humidity of over 80% and the temperature of over 30 °C.
	Wireless LAN adapter	UTY-TFSXZ1	Remotely manage an air conditioning system using mobile devices such as smartphones and tablets. For connection indoor unit with UART interface.
	Modbus converter	UTY-VMSX	For connection between indoor unit with UART interface and a Modbus open network.
	KNX converter	UTY-VKSX	For connection between indoor unit with UART interface and a KNX open network.

Exterior	Part name	Model name	Summary
	External switch controller	UTY-TERX	Air conditioner switching can be controlled by connecting other external sensor switches.

**NOTE:** Combined use of following optional parts and Wireless LAN adapter (UTY-TFSXZ1) is not allowed.

- Modbus converter
- KNX converter

## ■ Parts (for Outdoor unit)

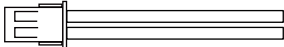
Exterior	Part name	Model name	Summary
	External connect kit	UTY-XWZXZ3	Use to operate the external input and output functions of outdoor unit.

## 7. Refrigerant system diagrams

### 7-1. Models: AOYG36KRTA, AOYG45KRTA, and AOYG54KRTA

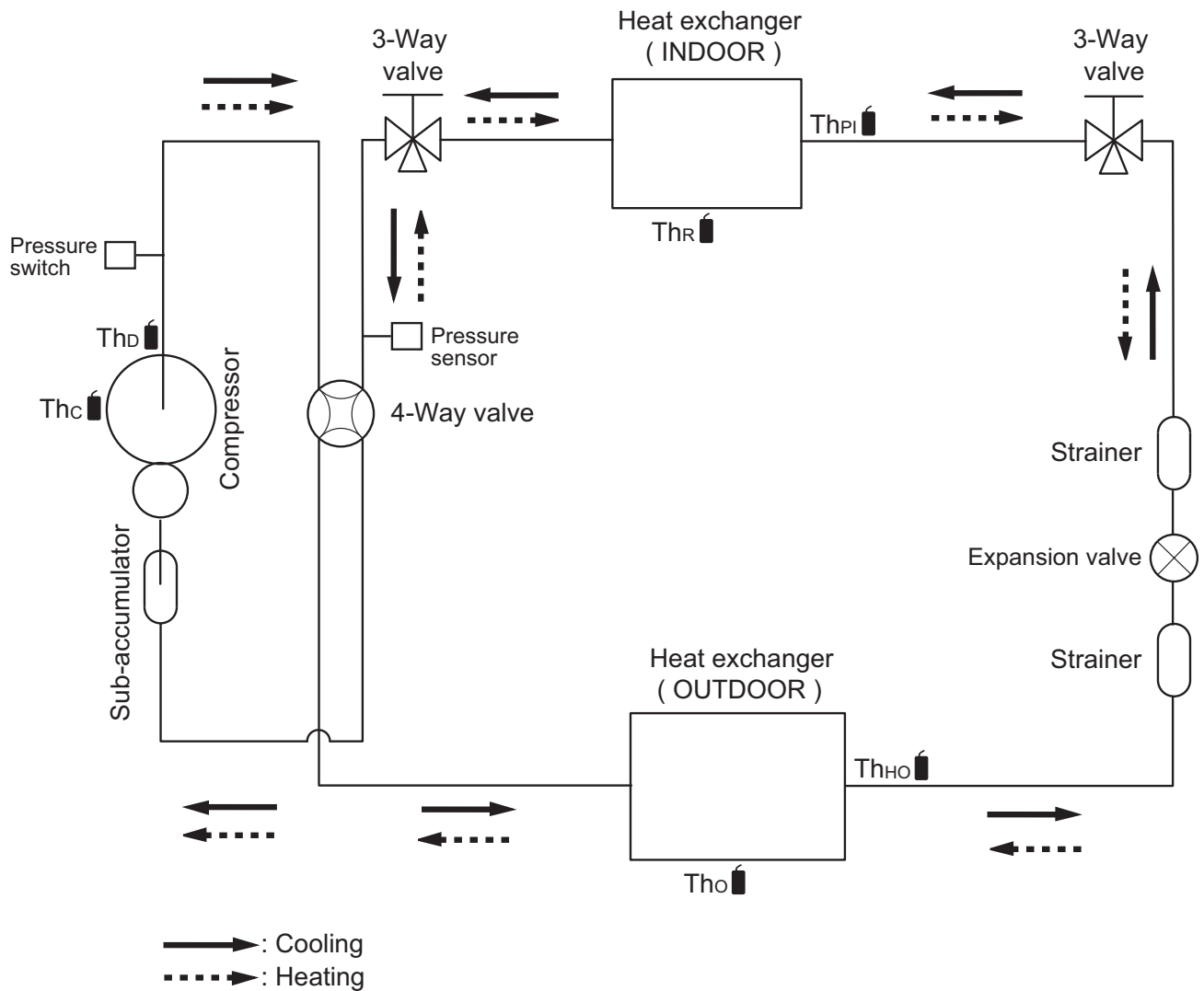

Th<sub>c</sub> : Thermistor (Compressor temperature)

Th<sub>D</sub> : Thermistor (Discharge temperature)

Th<sub>o</sub> : Thermistor (Outdoor temperature)

Th<sub>HO</sub> : Thermistor (Heat Exchanger Out temperature)

Th<sub>R</sub> : Thermistor (Room temperature)

Th<sub>PI</sub> : Thermistor (Pipe temperature)



# 8-2. Model: ARXG18KLLAP

TECHNICAL DATA AND PARTS LIST

TECHNICAL DATA AND PARTS LIST

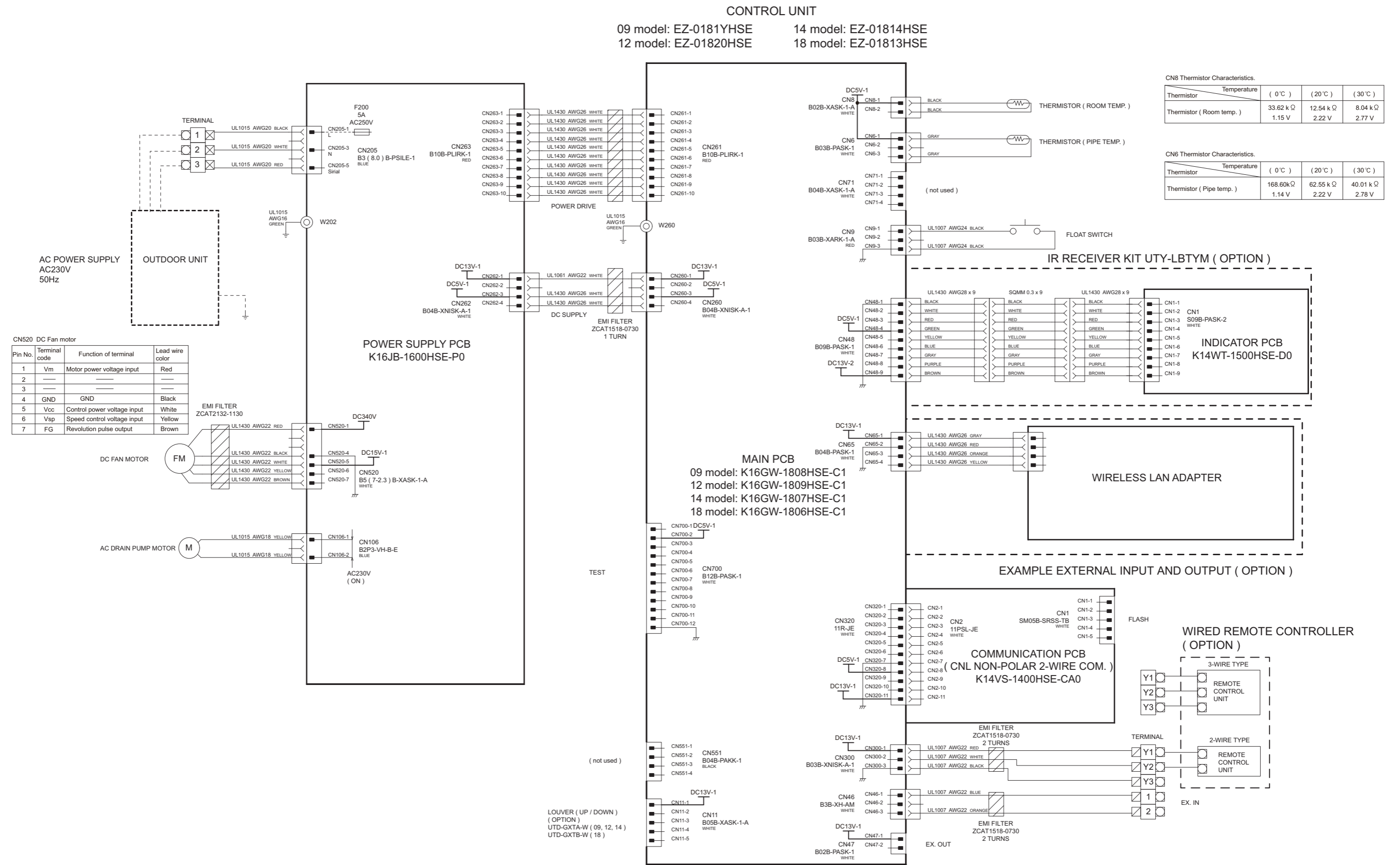

### 8-3. Models: ARXG22KMLA and ARXG24KMLA

TECHNICAL DATA AND PARTS LIST

TECHNICAL DATA AND PARTS LIST

CONTROL UNIT  
22 model: EZ-01811HSE  
24 model: EZ-0182EHSE

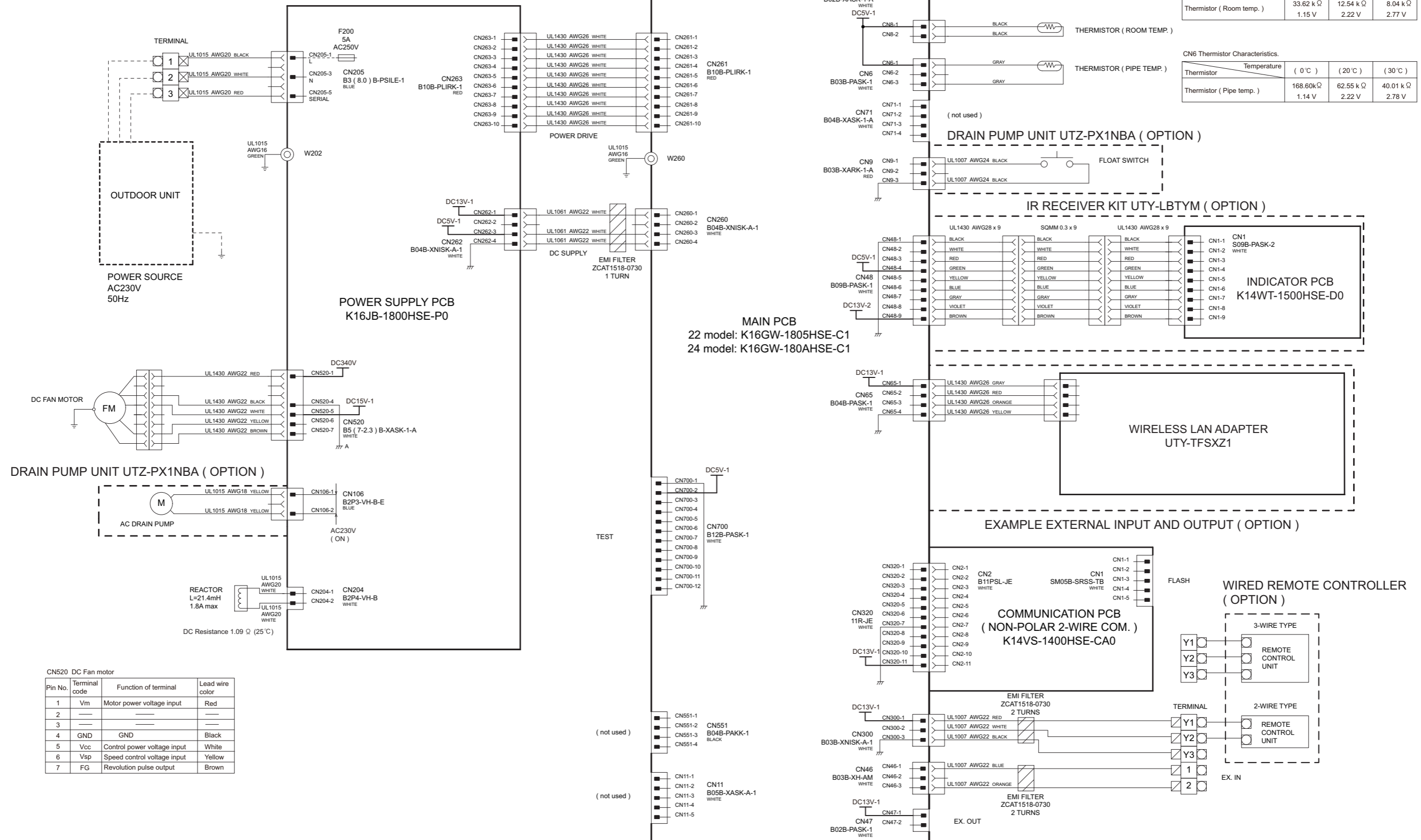

# 8-4. Models: AOYG36KRTA, AOYG45KRTA, and AOYG54KRTA

TECHNICAL DATA AND PARTS LIST

TECHNICAL DATA AND PARTS LIST

INVERTER ASSEMBLY  
 36 model: EZ-0190HUE  
 45 model: EZ-0191HUE  
 54 model: EZ-0191HUE

