

AIR HANDLING UNIT WITH HEAT RECOVERY SYSTEM

AmberAir Compact 3 CX V

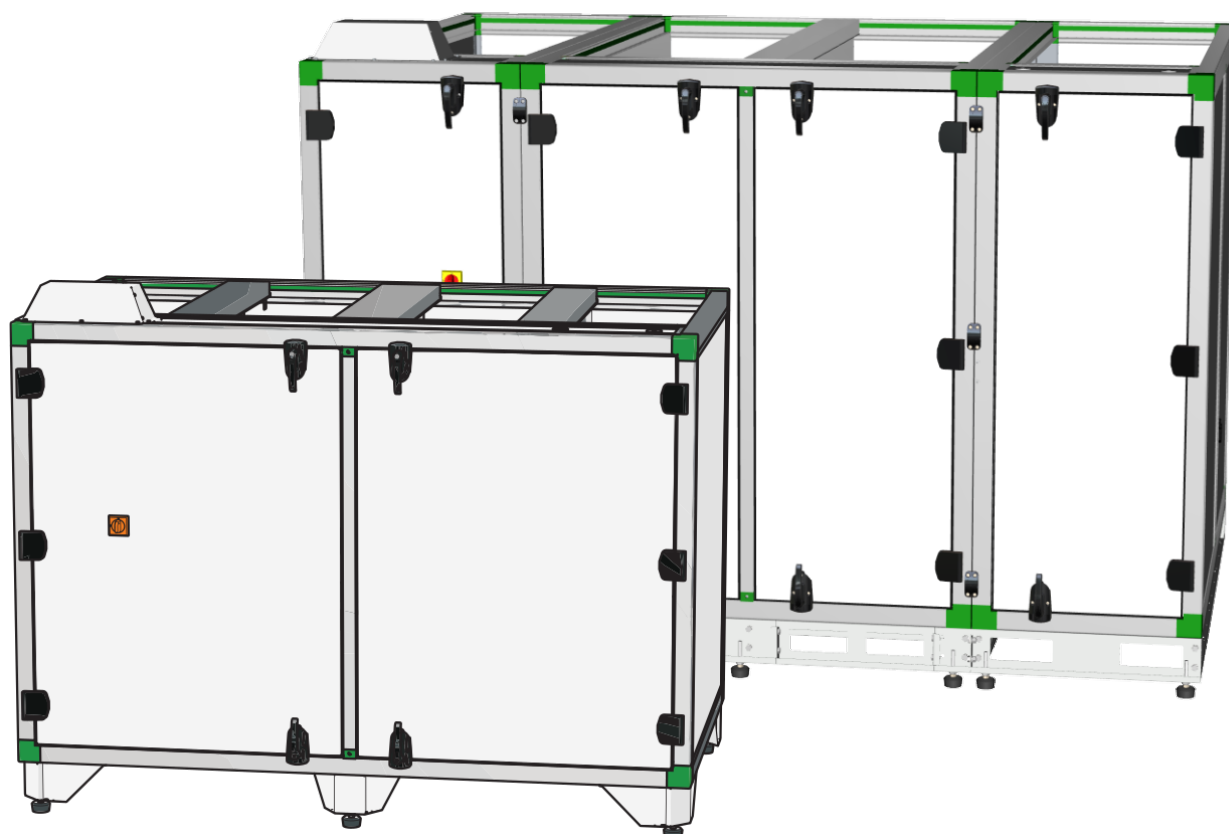

Mounting and installation instructions

Contents

Safety instructions and precautions	3
Information about the product	5
<i>Description</i>	5
Casing	6
<i>Dimensions and weight</i>	7
<i>Technical data</i>	8
<i>Air flow diagram</i>	10
<i>Operating conditions</i>	11
<i>Standard package of components</i>	11
<i>Components</i>	12
<i>Accessories</i>	13
Installation	15
<i>Reception of goods</i>	15
<i>Transportation and storage</i>	15
<i>Unpacking</i>	18
<i>Mounting diagram</i>	19
<i>Mounting</i>	21
Mounting position	23
<i>Drainage</i>	24
<i>Connection of air ducts</i>	25
<i>Filter box mounting</i>	26
<i>Connection of accessories</i>	27
Arrangement of controller connections in MCB	27
Arrangement of controller connections in EX1	30
Arrangement of controller connections in EX2	32
Abbreviation in electrical circuit diagrams	35
Electrical external pre-heater	36
External water pre-heater	37
External water cooler	38
External DX cooler	39
Fire protection connection	40
Motorised air dampers	41
CO2 arba RH sensors	42
Unit status indication / mode change / fire alarm inlet / fireplace function input	43
<i>Connection of the unit to electric network</i>	44
<i>Start-up recommendations</i>	44
System protection	44
Recommendations before the start of the unit (before the final user)	44
Possible faults and troubleshooting	45
Declaration of conformity	46
Ecodesign	47

Safety instructions and precautions





Device is manufactured in compliance with the following directives:

- Machinery Directive, 2006/42/EC;
- Low Voltage Directive, EEC 2006/95;
- Electromagnetic Compatibility Directive, 2004/108/EC;
- Ecodesign Directive, No 1253/2014.

Read this instruction very carefully before installing and using this equipment. Installation, connection and maintenance should be carried out by a qualified technician and in accordance with the local rules and legal acts.

The company shall take no responsibility for the injuries suffered by the people or for the damaged property, if the safety requirements are not followed or the device is modified without the permission of the manufacturer.

Main safety rules

	<p>Danger</p> <ul style="list-style-type: none"> • Before performing any electricity or maintenance tasks make sure, that the device is disconnected from the mains, that all moving parts of the device have stopped. • Make sure that the fans can not be entered through air ducts or branch openings. • If you notice liquids on electric parts or connections that bear voltage, stop the operation of the appliance. • Do not plug the device into the mains, that differs from the one indicated on the label or on the housing. • Voltage of the mains should comply with the electrotechnical parameters indicated on the label. • The device should be earthed in accordance with the rules of installation of electric appliances. It is forbidden to turn on and use unearthed device. Follow the requirements of the device's labels that indicate Danger.
	<p>Warnings</p> <ul style="list-style-type: none"> • Connection of electricity and maintenance of the device should be performed only by a qualified personnel, in accordance with the manufacturer's instructions and valid safety requirements. • In order to reduce the risk during installation and maintenance, suitable protective clothes should be worn. • Beware of sharp angles while performing installation and maintenance tasks. • Do not touch heating elements until they haven't cooled down. • Some devices are heavy, thus one should be very careful while transporting and installing. Use suitable lifting equipment. • While connecting electricity to the mains a circuit breaker of suitable size is necessary.
	<p>Warning!</p> <ul style="list-style-type: none"> • If the device is installed in a cold environment, make sure that all connections and tubes are properly isolated. Intake and discharge air ducts should be isolated in all cases. • Openings of the ducts should be covered during transportation and installation. • Make sure not to damage the heater when connecting the piping of the water heater. For tightening up, use a wrench/spanner.
	<p>Before starting the equipment</p> <ul style="list-style-type: none"> • make sure, that there are no strange objects inside; • manually check whether fans are not stuck or blocked; • if rotary heat exchanger is installed in the device, make sure that it is not stuck or blocked; • check the grounding; • make sure that all components and accessories are connected in accordance with the project or provided instructions.
	<p>Danger: Fumes</p> <p><i>Salda Antifrost</i> system uses dis-balancing of the air flow and it may cause negative pressure in premises. Great care should be taken when using at the same time in premises as another heating appliance what depend on the air in premises. Such appliances include gas, oil, wood or coal-fired boilers and heaters, freplaces, continuous flow or other water heaters, gas hobs, cookers or ovens which draw air in from the room and duct exhaust gases out through a chimney or extraction ducting. The heating appliance can be starved of oxygen, impairing combustion. In exceptional cases harmful gases could be drawn out of the chimney or extraction ducting back into the room. In this case we strictly recommend to turn off <i>Salda Antifrost</i> and use an external preheater for heat exchanger anti-frost protection (see <i>Salda Antifrost</i> function on the Remote controller manual).</p>

 <p>Warning - pay attention</p>	 <p>Additional information</p>
---	--

Stick the auxiliary label on the unit (on an easily accessible place) or on the dashed place of a technical manual in order to keep the important information about the unit.



- 1 - Logo
- 2 - Internal usage code
- 3 - Brand name
- 4 - Technical data
- 5 - Units number
- 6 - Web address

STICK HERE

SALDA

 200003025720

PAVADINIMAS

(IV)	0.084 kW; 0.93 A; 230/50 V/Hz; ~1	(V)	0.095 kW; 0.93 A; 230/50 V/Hz; ~1	(E)	0 V/Hz; ~0	 
(F)	0 V/Hz; ~0	(G)	0 V/Hz; ~0	(M)	0.005 kW; 0.021 A; 24/50 V/Hz; ~	
TOTAL: 0.17 kW; 1.87 A; IP-34						

gu072489 / 2014.03

www.salda.lt



Units tested and produced according to EC directives



AmberAir Compact units are Eurovent Certita Certification certified in AHU program.



SALDA - associated member of the Eurovent association (Europe's Industry Association for Indoor Climate (HVAC), Process Cooling, and Food Cold Chain Technologies)

VDI 6022

AmberAir Compact SD50+ units designed of the VDI 6022 Part 1 guideline (Hygiene requirements for ventilation and air-conditioning systems and units)



SALDA world like to inform you that based on the Commission Regulation (EU) No 1253/2014 for enforcing directive 2009/125/EC (hereinafter referred to as ErP directive), the operational area of certain AHU within the European Union is regulated by certain conditions

The AHU can only be used within the EU when it meets the requirements of the ErP directive. If certain AHU doesn't have CE mark on it, it is strictly forbidden to use it in the EU.

Information about the product

Description

AmberAir Compact is a compact-class ventilation unit with a heat recovery system. Its technical parameters are provided in the tables below.

Parameter	Value
Model size	3-CXV SD50+ RF2B1E2C1P
Heat exchange type	Counterflow
Installation type	Vertical
Service side	Right
Fan type	EC
By-pass damper	100%
Integrated heater	Electrical
Control type	Comfort MCB
Filter type	Panel
Outdoor installation version	Outdoor

Selected parameters

Parameter	Unit of measurement	Value	
		Winter	Summer
Air flow (supply)	[m ³ /h]	3000	3000
Air flow (extract)	[m ³ /h]	3000	3000
External pressure (supply)	[Pa]	300	300
External pressure (extract)	[Pa]	300	300
Outdoor air temperature	[°C]	-23	32
Outdoor air humidity	[%]	90	60
Extract air temperature	[°C]	20	23
Extract air humidity	[°C]	40	60

Thank you for purchasing the devices of our company!



Not suitable for swimming pools, saunas and other similar facilities.

Casing

The casing of AmberAir Compact SD50+ shows exclusive tightness and thermal characteristics. More detailed information is provided in the tables below.

EN 1886:2008 parametrai

Model Box	SD50+
Casing strength class	D1(M)
Casing air leakage class at - 400 Pa	L1(M)
Casing air leakage class at + 700 Pa	L1(M)
Filter bypass leakage class	F9(M)
Thermal transmittance class	T2
Thermal bridging factor class	TB2
Casing profiles options	Aluminium without thermal break
Corners	Plastic
Corners flammability (UL 94)	HB
Thickness of double skin panel	45,5 mm
Insulation material	Polyurethane foam
Insulation material density	45 kg/m ³
Insulation material thermal conductivity	0,024 W/mK
Insulation material fire reaction class (EN 13501-1:2007)	B - s2 d0
External sheet metal thickness and coating options	0,5 mm Zn polyester painting RAL 7040
Internal sheet metal thickness and coating options	0,5 mm Zn

AmberAir Compact SD50+ has rounded internal corners, which prevents accumulation of dust and dirt, facilitates cleaning and makes it possible to use in a hygienic unit design.

AmberAir Compact SD50+ has thermal bridging factor class TB2 - it eliminates possibilities for condensate occurrence on outer surface of the unit.

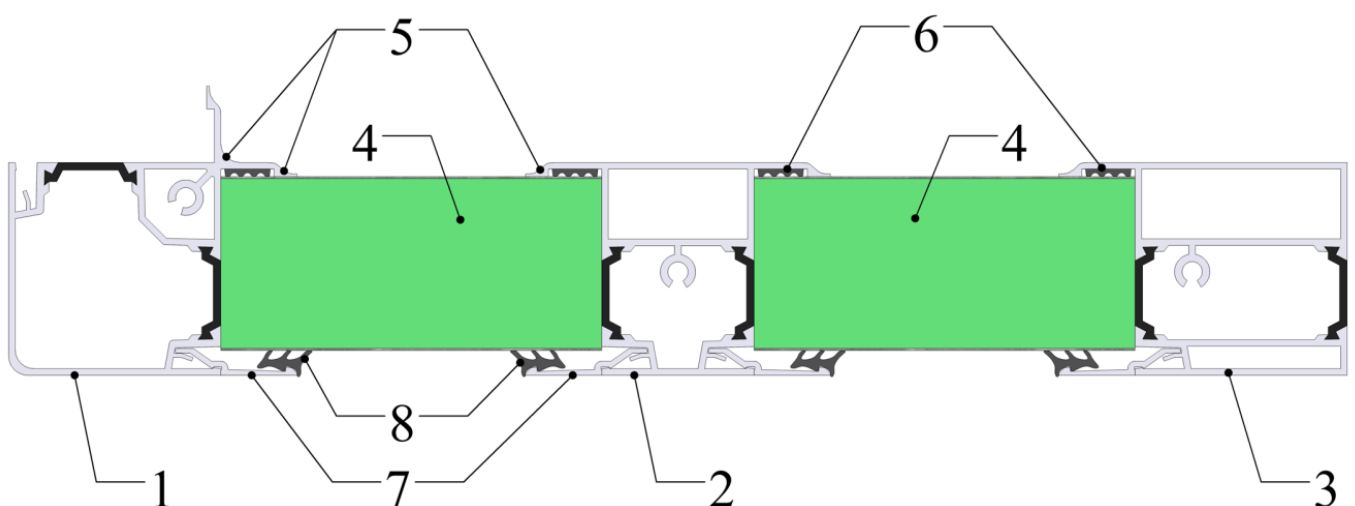

AmberAir Compact SD50+ cross-section

1 - Corner profile with thermal break strips, 2 - intermediate profile with thermal break strips, 3 - special corner profile with thermal break strips for connection between two sections, 4 - double skin polyurethane foam panel, 5 - rounded profile corners, 6 - non-porous gasket fitted in special groove, 7 - panel block aluminium profile, 8 - panel block gasket.

Dimensions and weight

ODA outdoor air

SUP supply air

EHA extract air

ETA exhaust air

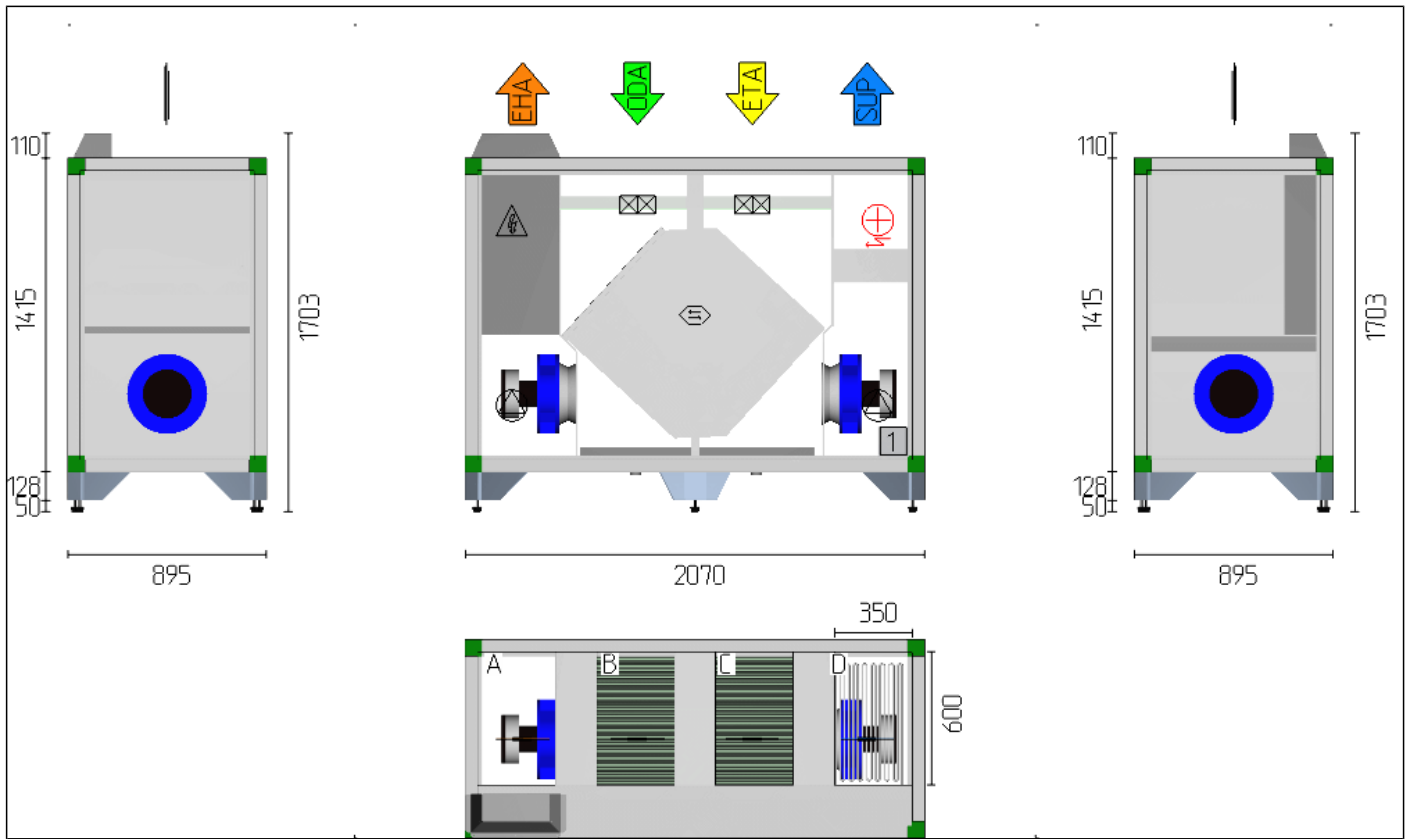

Weight (without package and accessories)

[kg]

369

Technical data

General parameters			
Parameter	Unit of measurement	Value	
Thermal input (EN 308)	[%]	83.75	
SFPv class (clean filters)	[kW/m ³ /s]	2.55	
SFPe class (design load)	[kW/m ³ /s]	2.8	
Energy efficiency class (Eurovent 2016)		A	
System pressure	[Pa]	300/300	
Maximum external leakage	[%]	<1	
Maximum internal leakage	[%]	<1	
Total power/current consumption	[kW/A]	8.85/12.77	
Phase/voltage/frequency	[f/VAC/Hz]	3/400/50	
Control board		Comfort MCB	
Insulation of walls	[mm]	45	
Fans			
Fan type		EC	
Impeller type		Backward curved	
Supply air fan			
Phase/voltage/frequency	[f/VAC/Hz]	1/230/50	
Power/current	[kW/A]	1.17592/6.7	
Speed	[min ⁻¹]	2770	
Control input	[VDC]	0-10	
Protection class		IP54	
Exhaust air fan			
Phase/voltage/frequency	[f/VAC/Hz]	1/230/50	
Power/current	[kW/A]	1.17592/6.7	
Speed	[min ⁻¹]	2757	
Control input	[VDC]	0-10	
Protection class		IP54	
Integrated electrical heater			
Phase/voltage/frequency	[f/VAC/Hz]	3/400/50	
Power/current	[kW/A]	6/8.66	
Control input	[VDC]	0-10	
Protection class		IP30	
Filters			
Supply air filter			
Class		F7	
Width	[mm]	565	
Height	[mm]	395	
Thickness	[mm]	46	
Model		MPL 565x395x46-F7	
Exhaust air filter			
Class		M5	
Width	[mm]	565	
Height	[mm]	395	
Thickness	[mm]	46	
Model		MPL 565x395x46-M5	
Pressure losses			
Assembly	Unit of measurement	Supply air	Exhaust air
Heat exchanger	[Pa]	275	307
Heater	[Pa]	9	-
Filter	[Pa]	158	95

Dampers	[Pa]	34	-
Total	[Pa]	476	402
Total system pressure	[Pa]	300	300
Fan pressure losses	[Pa]	48	110
Stationary pressure produced by fans	[Pa]	776	702

Air flow diagram

- operational limits
- - power consumption

Supply air

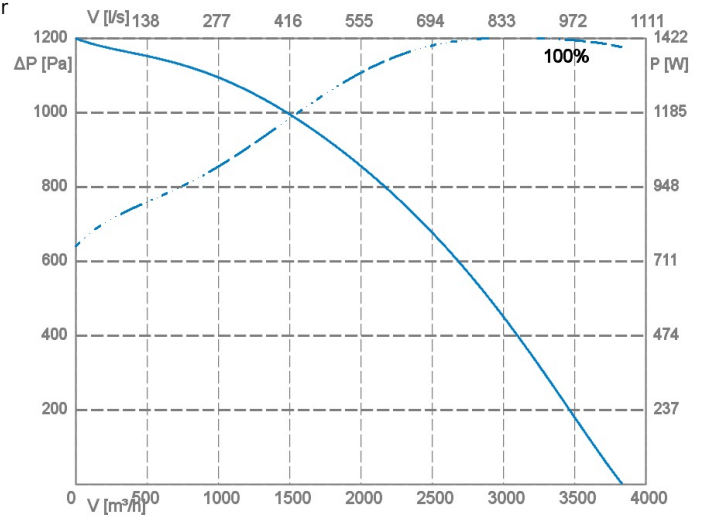

Exhaust air

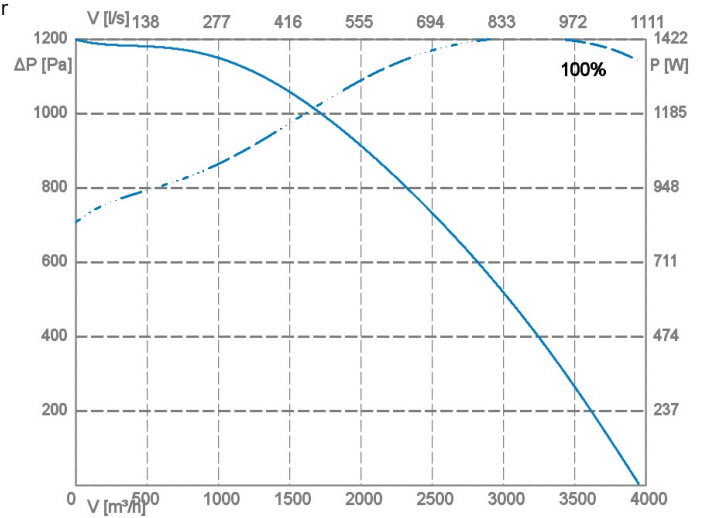

Operating conditions

Place of operation	Indoors / outdoors / indoors and outdoors / outdoors with special accessories	
Operation in explosive environment		prohibited
Transporting of the polluted air		prohibited
Outdoor air temperature without preheater (Salda Antifrost** off)	[°C]	-5/+40*
Outdoor air temperature without preheater (Salda Antifrost** on)	[°C]	-15/+40
Outdoor air temperature limits with a selected pre-heater on an air duct	[°C]	-40/+40
Outdoor air max humidity	[%]	90
Temperature limits of an extracted air	[°C]	+15 / +40
Extract air max humidity	[%]	60
Room temperature range for installing the unit	[°C]	0 / +40

* – when relative humidity of extracted air is lower than 35 %.

** – uses dis-balancing of the air flow and it may cause negative pressure in premises.

The air handling units installed outdoors shall be started only when the following obligatory conditions established by the manufacturer are met:

- Units that are stored at the site before installation shall be sealed using additional means in order to prevent the accumulation of moisture inside the unit.
- If the unit is installed and is not started for continuous operation, it must be ensured that no warm/humid air enters the unit through air ducts and that no moisture condensates inside the unit.
- If the ventilation units stand idle for a long time or are started infrequently, the system must be blown down at the maximum capacity 1/24 h to dehumidify.
- Voltage to the automatics of the unit is installed and connected; the system of water products is filled with glycol/water.

In case of failure to comply with the requirements set out above, the manufacturer shall have the right not to apply the warranty in respect of the occurrence of moisture/water in damaged components.

Standard package of components

Standard package (without optional accessories) includes:



Control board protection roofing
1 pcs.

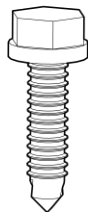

Self-tapping screw for roofing
7 pcs.



Locking handle
2 pcs. (Compact 1-5 CX V)
4 pcs. (Compact 6-7 CX V)



Non-locking handle
2 pcs. (Compact 1-5 CX V)
4 pcs. (Compact 6-7 CX V)

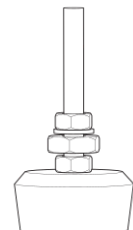

Anti-vibration pad
6 pcs. (Compact 1-5 CX V)
14 pcs. (Compact 6-7 CX V)

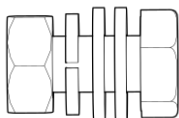

Set of bolts for pad connection
8 pcs. (Compact 6-7 CX V)



Set of bolts and nuts for sections connection
12 pcs. (Compact 6-7 CX V)



Supply air temperature sensor TJ
1 pcs.

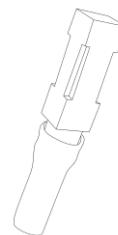

Water temperature sensor for water heater TV1
1 pcs. (water version only)

Components

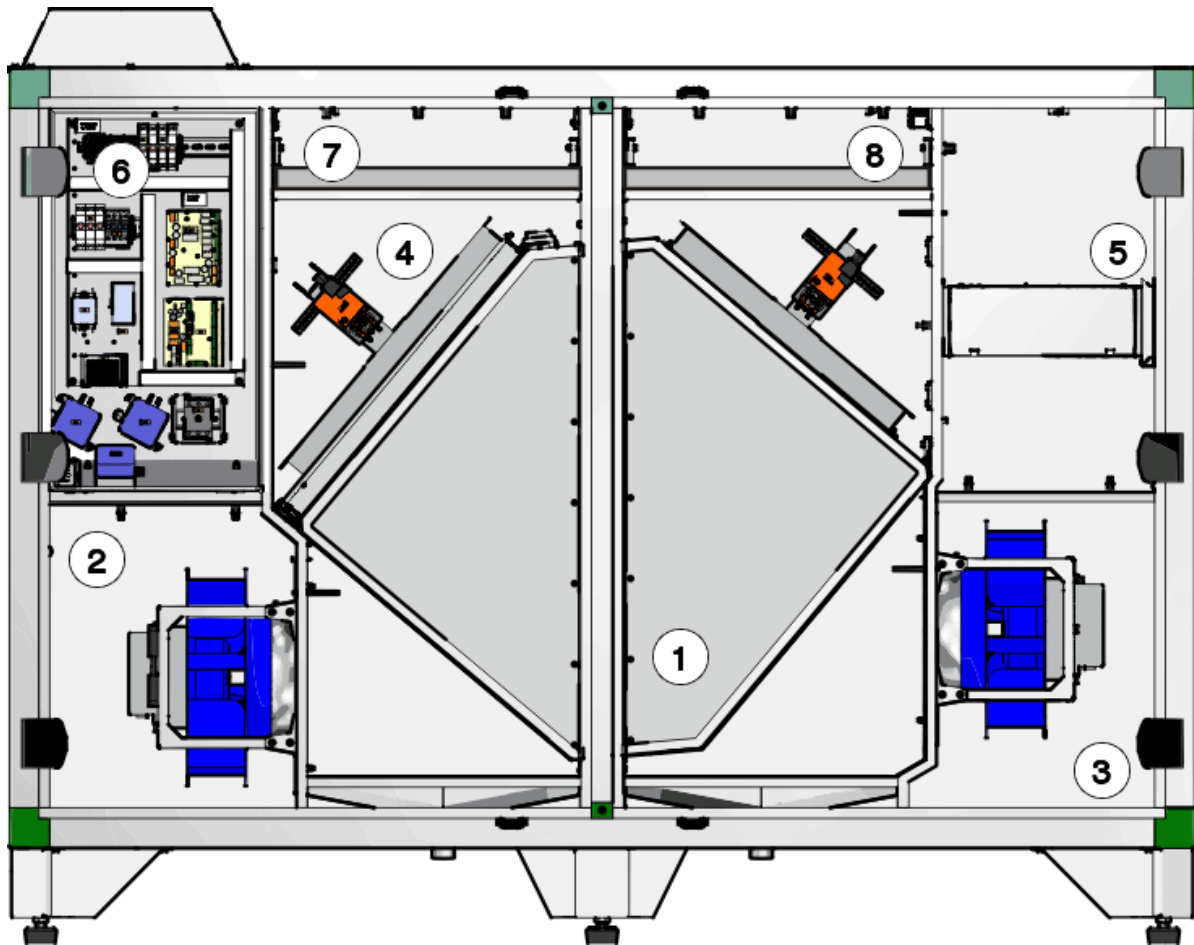

1. Heat exchanger
2. Exhaust air fan
3. Supply air fan
4. By-pass
5. Electrical heater
6. Control board
7. Supply air filter
8. Exhaust air filter

Accessories



Stouch



Ptouch



MB-Gateway



S-RCO2-F2



S-RFF-U-D-F2



S-KFF-U



S-KCO2



UG3-A40



IR24- PC



PIR



Energy meter



Push button, impulse



LF230



TF230



NFA



NM230A-TP



RMG



VVP



VXP



STP-IR



LJ/E



SSKM

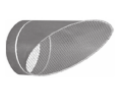

ABV



SKG-A

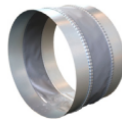

LSF

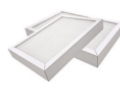

MPL



AKS

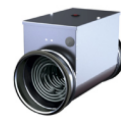

EKA NIS

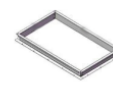

RF

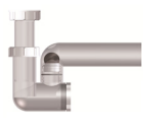

Condensate trap



SSP

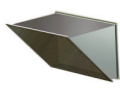

OC



EKS NIS



AVA



AVA-DX



BFB



MUTE

		GsfstPRI161_316
Outlet-intake cover	Outlet ABV 400	GFDABV0400
		GLJLJ/PG091
		GSKSSKM003
Rectangular duct silencer SSP	SSP 600x350x100-3	GSOSSP0216_024
Duct water cooler AVA	AVA 400	GSIAVA007
DX Duct Cooler AVA-DX	AVA-DX 400	GSIAVA011
Double Filter boxes BFB	Double Filter Box BFB 600x350	GNGPR168_1076_0
Rectangular Flange for CXV	Rectangular Flange RF 600x3500	GNGPR168_1031_0
	Damper SKG-A 400	GSKSKG037
	LSVF 400	GVELSVF007
Circular duct silencer AKS	AKS 400-10	GSOAKS046
Room CO2 sensor S-RCO2-F2	S-RCO2-F2	ZAKKT0048
Duct CO2 sensor S-KCO2	S-KCO2	ZAKKT0049
Duct RH sensor S-KFF-U	S-KFF-U	ZAKKT0051
Room RH sensor S-RFF-U-D-F2	S-RFF-U-D-F2	ZAKKT0050
Control panel Stouch	Stouch	PRGPU051
Network module MB-Gateway	MB-Gateway	PRGPU082
Wireless Router	Wireless N Nano Router TL- WR802N	PRGPU105
Switch 774451_774411	Switch 774451_774411	ZEPSM001
Duct smoke detector Ug3a4o	Ug3a4o	ZAKKT0110
IR presence sensor IR24-P	IR24-P	ZAKJT019
IR presence sensor IR24-PC	IR24-PC	ZAKJT020
IR presence sensor PATROL 701	Patrol 701	ZAKJT021
Actuator for damper	NM230A-TP	ZAKP0055
Actuator for damper		ZAKP0063
Energy Analyzers	Energy Analyzer EM210 (Pulse)	ZAKKT0116
Current transformer	CTD1X705AXXX	ZAKTR0032
Energy Analyzers	Energy Analyzer (Pulse+ModBus)	ZAKKT0120
Energy Analyzers	Energy Analyzer EM24 (M-Bus)	ZAKKT0117

Installation

Reception of goods

Each device is thoroughly checked before transportation. While receiving goods it is recommended to check whether devices were not damaged during transportation. If a damage to the device is noticed, immediately address the representatives of a transport company. Please inform a representative of the manufacturer, if any deviation from the order is noticed.

Transportation and storage

- All units are packed in the factory to withstand regular conditions of transportation.
- The package is only for protection purpose!
- While unloading and storing the units, use suitable lifting equipment to avoid damages and injuries. Do not lift units by holding on power supply cables, connection boxes, air extract or exhaust flanges. Avoid hits and shock overloads. Before installation units must be stored in a dry room with the relative air humidity not exceeding 70% (at +20 °C) and with the average ambient temperature ranging between +5 °C and +30 °C. The place of storage must be protected against dirt and water.
- The units must be transported to the storage or installation site using forklifts.
- The storage is not recommended for a period longer than one year. In case of storage longer than one year, before the installation it is necessary to verify whether the bearings of fans and motor rotate easily (turn the impeller by hand) and if the electric circuit insulation is not damaged or the moisture is accumulated.
- AmberAir Compact of sizes 1-5 CX V are lifted from the pallet with a forklift or slings, which are roved through the supporting legs (four corners).
- AmberAir Compact of sizes 6-7 CX V are lifted from the pallet with a forklift at the recesses at the supporting base, or with slings.



When lifting with a forklift, protect the condensate drainage pipes. The product is heavy. Exercise caution when transporting and installing.

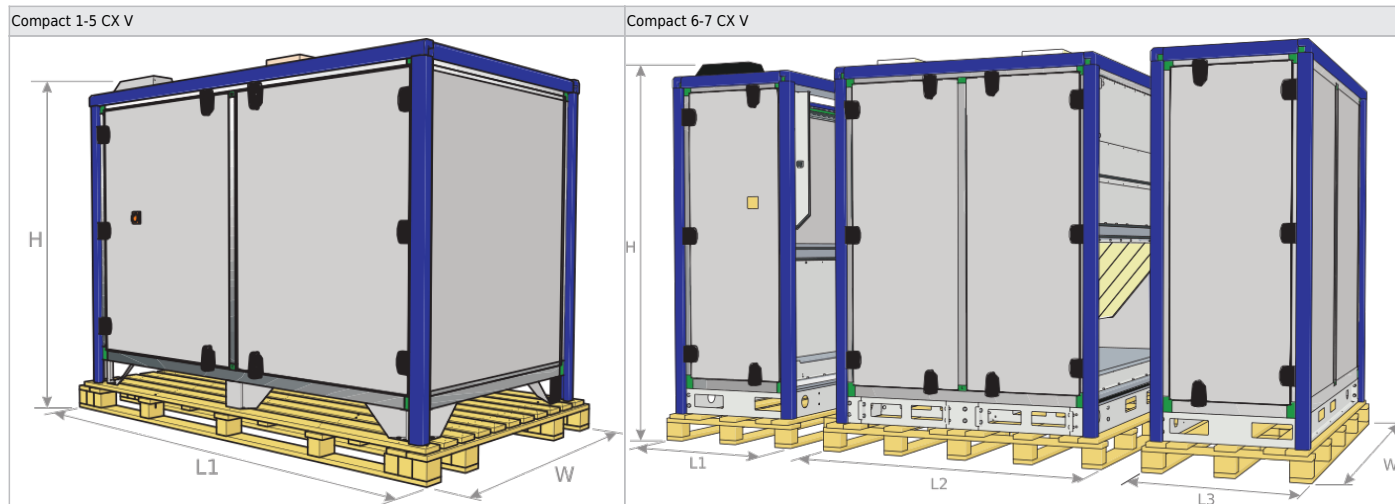

Unit	Dimensions, [mm]				
	H	W	L1	L2	L3
Comapct 1 CX V	1685	1080	2150	-	-
Comapct 2 CX V	1745	1080	2150	-	-
Comapct 3 CX V	1800	1080	2150	-	-
Comapct 4 CX V	1800	1400	2150	-	-
Comapct 5 CX V	1845	1440	2400	-	-
Comapct 6 CX V	2055	1750	800	1540	800
Comapct 7 CX V	2095	2100	800	1540	800

The product can be lifted with a forklift or a crane using slings.

When lifting with a forklift, the length of the fork must be greater than the length or width of the product (depending on the product version). The condensate pipes must be protected against damage.

The inner legs of the product of AmberAir Compact 1-5 CX V versions are covered with protection to prevent damage of the condensate drainage pipes. Therefore, when lifting with a forklift, the width of the fork must be greater than the condensate protection width.

AmberAir Compact 1-5 CX V lifting with a forklift

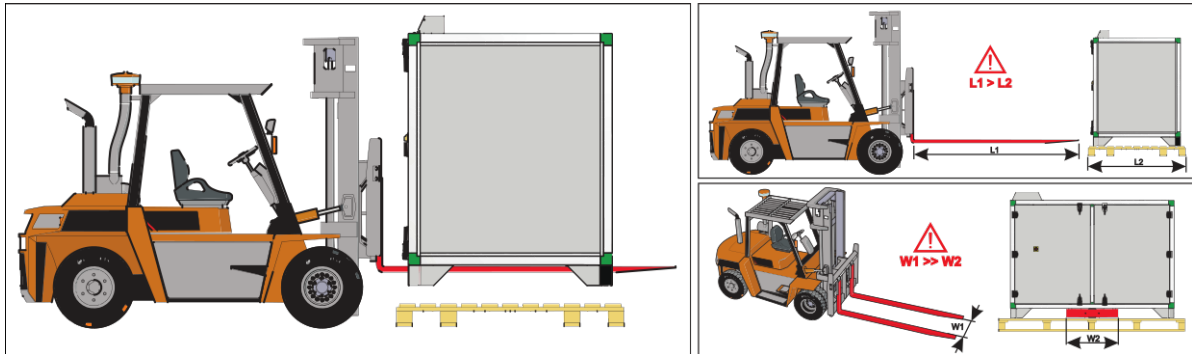

AmberAir Compact 6-7 CX V lifting with a forklift

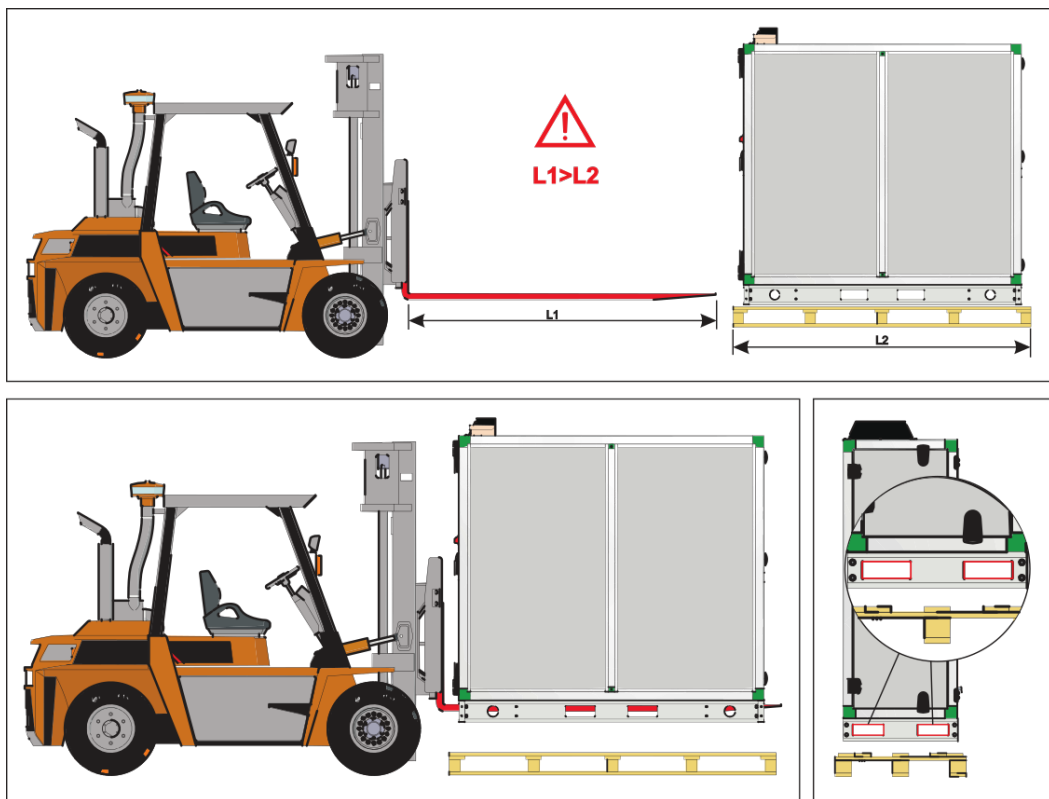

When lifting the product with slings, it is necessary to insert spacers between them in order to prevent damage to the casing of the product.

AmberAir Compact 1-5 CX V lifting with slings

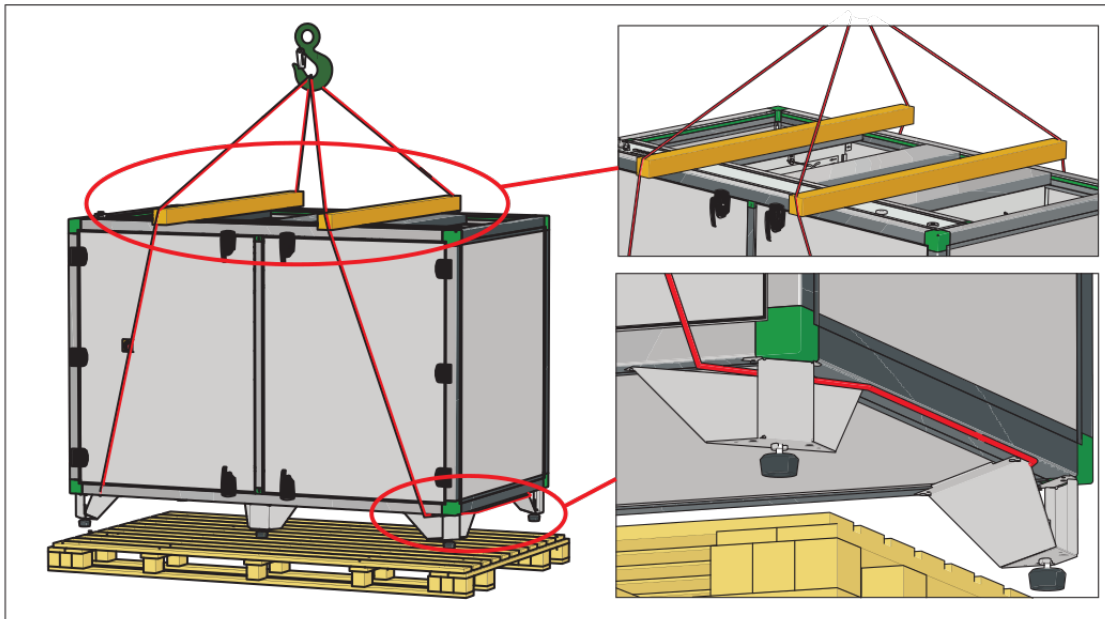

AmberAir Compact 6-7 CX V lifting with slings

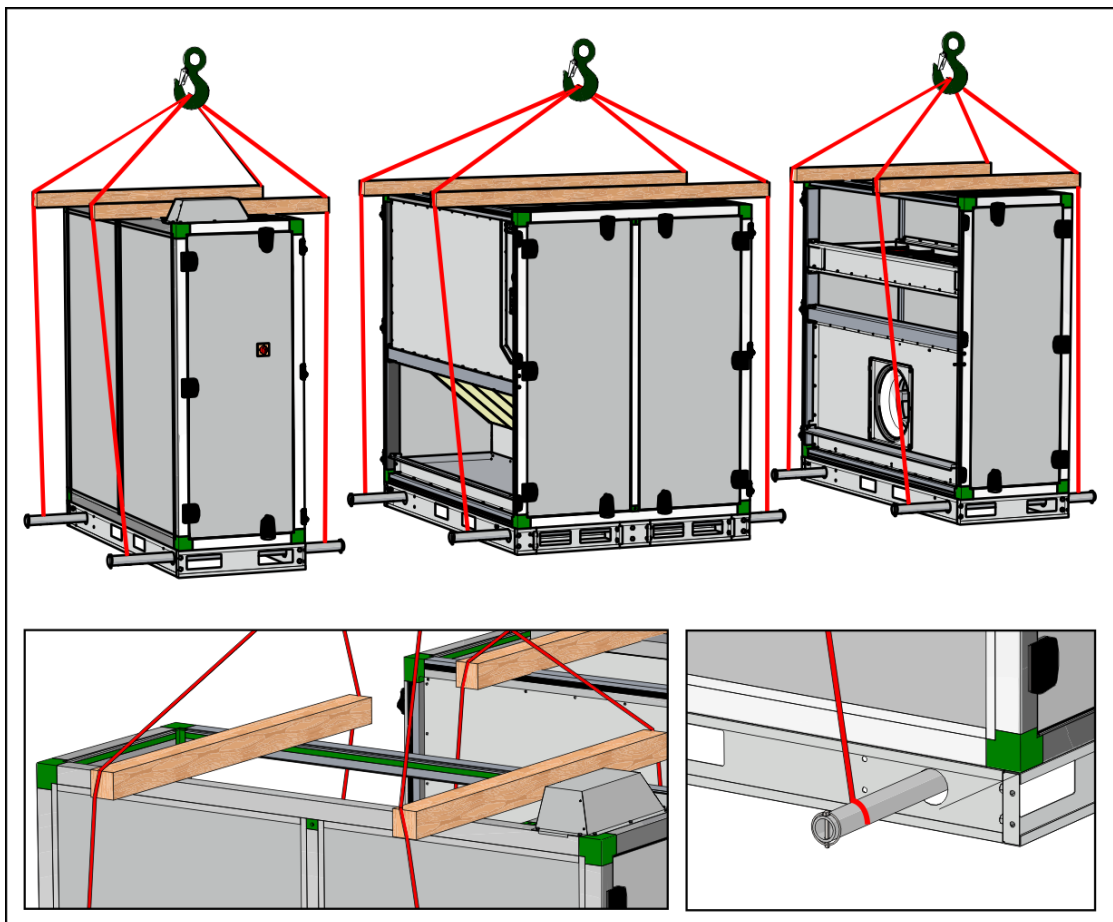

Unpacking

- Remove the film from the unit.
- Remove the tightening packaging tapes which keep the protective profiles.
- Remove the protective profiles.
- Unscrew the wood screws which fasten the unit legs to the pallet.
- After unpacking the unit, examine it to make sure that it has not been damaged during transportation. The installation of damaged units is prohibited!
- AmberAir Compact of sizes 1-5 CX V are lifted from the pallet with a forklift or slings, which are roved through the supporting legs (four corners).
- AmberAir Compact of sizes 6-7 CX V are lifted from the pallet with a forklift at the recesses at the supporting base, or with slings.

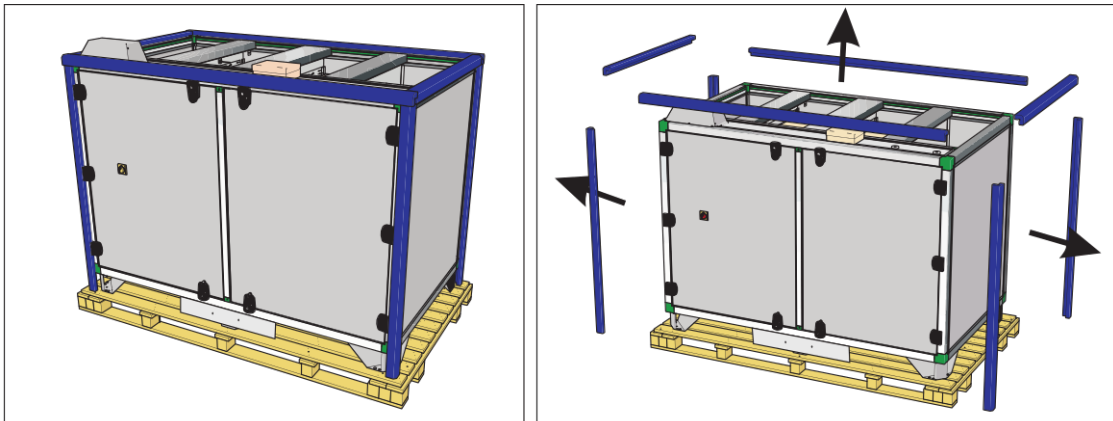
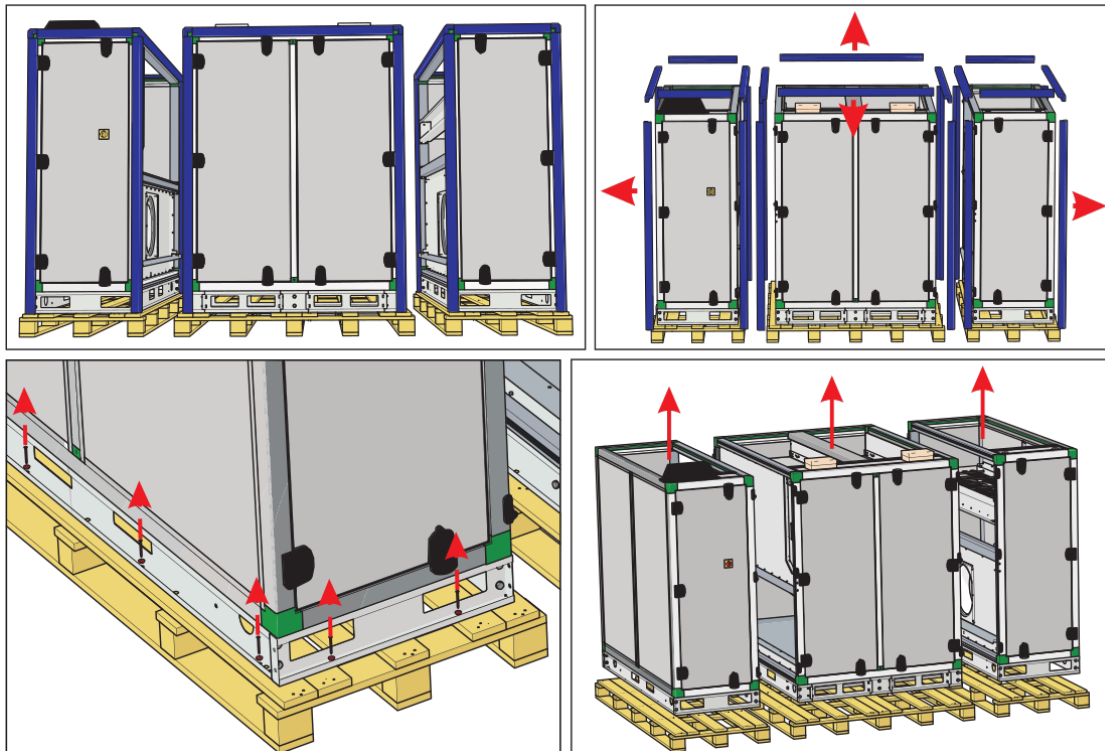

When lifting with a forklift, protect the condensate drainage pipes.

AmberAir Compact 1-5 CX V*AmberAir Compact 6-7 CX V*



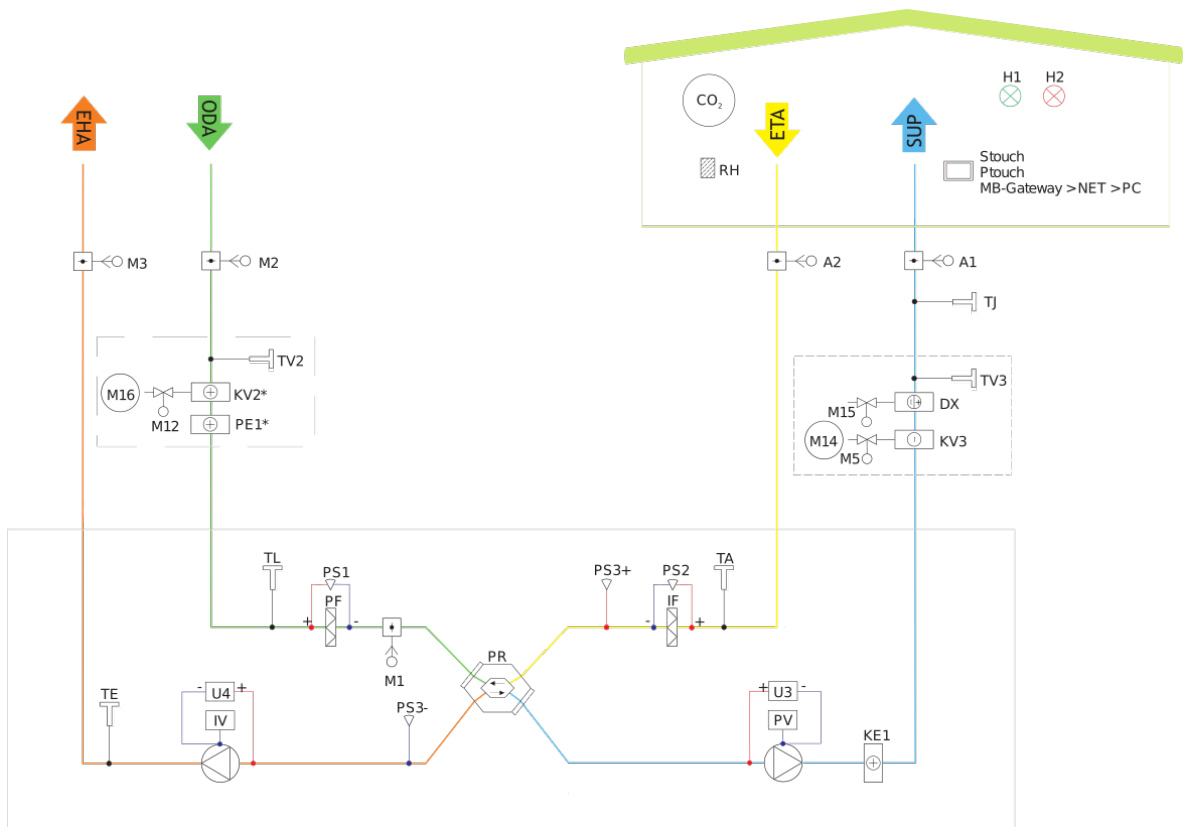

Mounting diagram

Electrical version

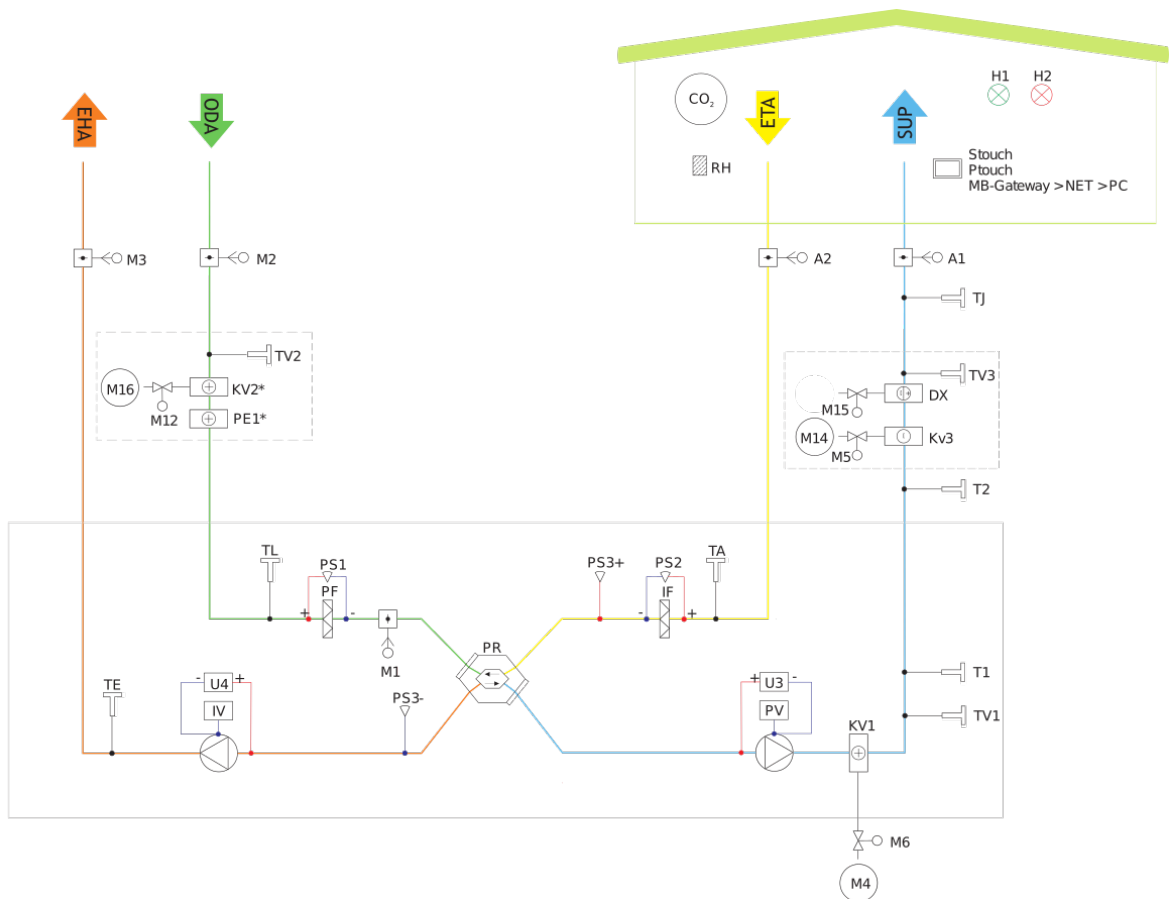

Water version



List of component	
PR	Plate heat exchanger
PV	Supply air fan
IF	Extract air filter
PF	Supply air filter
IV	Exhaust fan
KE1	Electric heater
PE1	Electric pre-heater (the electric and water pre-heaters may not be used at the same time)
KV1	Water heater (the possibility of the heating switch function)
KV2	Water pre-heater (the electric and water pre-heaters may not be used at the same time)
KV3	Water/DX cooler (the water and DX coolers may not be used at the same time)
M1	Actuator by-pass damper
M2	Supply air damper actuator
M3	Exhaust air damper actuator
M4	Water heater circulation pump
M5	Water cooler valve motor
M6	Water heater valve motor
M12	Water pre-heater valve motor
M14	Water cooler circulation pump
M15	DX cooler valve actuator
M16	Water pre-heater circulation pump
A1	Fire alarm damper actuator I
A2	Fire alarm damper actuator II
TJ	Supply air temperature sensor
TL	Outdoor air temperature sensor
TE	Exhaust air temperature sensor
TA	Extract air temperature sensor
DTJ	Extract air temperature and RH sensor
TV1	Water heater temperature sensor
TV2	Water preheater temperature sensor
TV3	Water cooler temperature sensor
T1	Water heater thermostat
T2	Cooler switching thermostat
PS1	Supply air filter switch (NO)
PS2	Extract air filter pressure switch (NO)
PS3	Heat converter pressure switch (NC)
U3	Supply air fan pressure sensor
U4	Extract air fan pressure sensor
 DDA	Outdoor air
 SUP	Exhaust air
 EHA	Extract air
 ETA	Supply air
RH	Relative humidity sensor
CO₂	CO ₂ sensor
Stouch	Remote control panel
Ptouch	Remote control panel
MB-Gateway	Network module
NET	Network
PC	Computer
	Ventilated premises
Galimi PCB įėjimai/išėjimai	
FA	Fire alarm
FPP	Fireplace protection
	System mode switch (START/STOP)
	Fans speed switch (BOOST)
H1	Operation indication output
H2	Alarm indication output

Mounting

- Installation should only be performed by qualified and trained staff.
- When connecting air ducts, consider the notices indicated on the casing of the unit.
- Before connecting to the air duct system, the connection openings of ventilation unit should be closed.
- When connecting the ducts, you should pay attention to the air flow direction indicated on the device housing.
- Do not connect the bends close to connection flanges of the unit. The minimum distance of the straight air duct between the unit and the first branch of the air duct in the supply air duct must be $1xD$, in air exhaust duct $3xD$, where D is diameter of the air duct.
- It is recommended to use the accessories-holders. This will reduce vibration transmitted by the unit to the air duct system and environment.
- Enough space must be left for opening of the maintenance door and filter covers.
- If the installed ventilation unit is adherent to the wall, it may transmit noise vibrations to the premises. Though the level of noise caused by the fans is admissible, it is recommended to mount the unit at the distance of 400 mm from the nearest wall. If it is not possible, the mounting of the unit is recommended on the wall of the room where the level of noise is not important.
- Ducts are connected to the unit in such way that they could be easily disassembled and the heater could be removed from the unit when performing service or repair works.



The protective film is intended to protect the unit during transportation. It is recommended to remove the film because otherwise oxidation signs may occur.

AmberAir Compact 1-5 CX V

The product should be slightly lifted and installed on the legs. The lifting methods are shown in the section "Transportation and Storage". Versions 1-5 of AmberAir Compact have drainage protection, which is removed after installing the legs. The protection is a part intended for transportation only and should not be reinstalled after mounting the drainage.

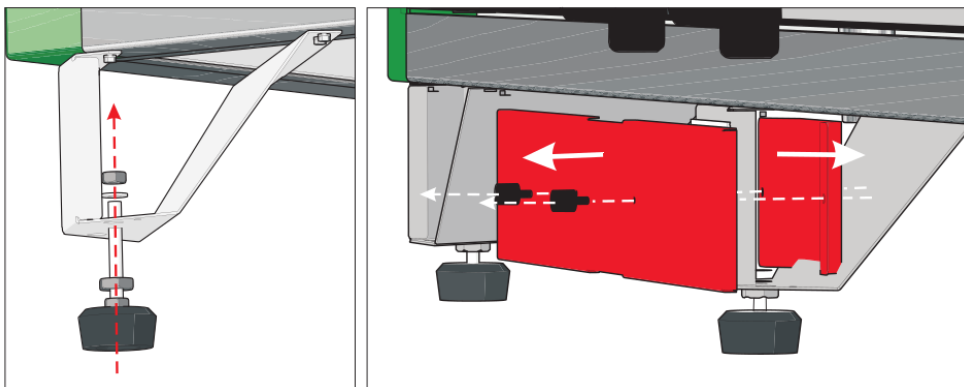

AmberAir Compact 6-7 CX V

The products shall be installed on the legs. In order to do so, the unit should be slightly lifted. The hoisting methods are shown in the section "Transportation and Storage".



It is recommended to connect the sections of the unit on the pallet.

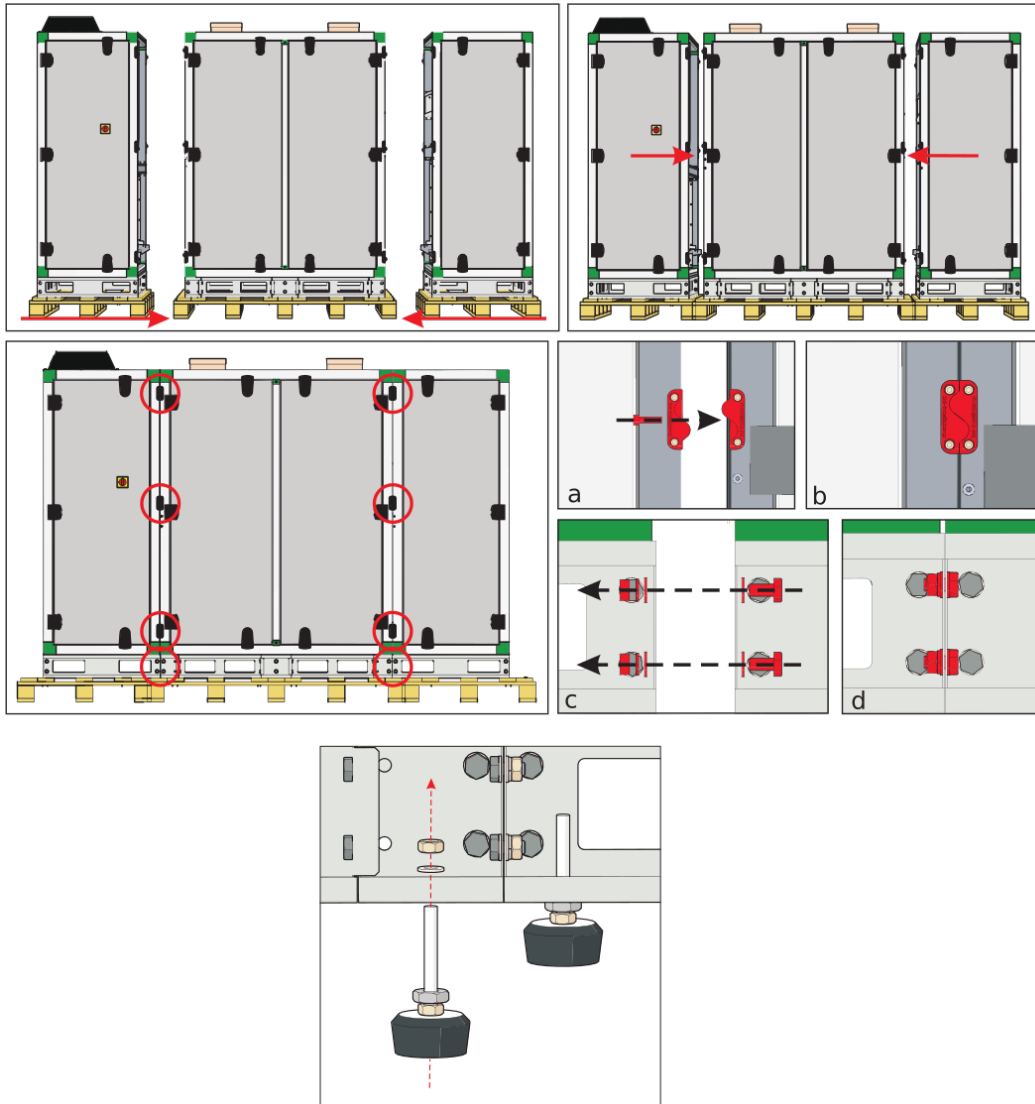

Mounting position

1. The installation position only in the horizontal direction.
2. Install the supporting legs.
3. AmberAir Compact of sizes 6-7 CX V are assembled from separate sections.
4. They must be adjusted without a gradient (because a gradient of 3° is aligned in the condensate drip trays).
5. Leave some space in the front so that it would be sufficient to open the doors and to remove or install a required component.

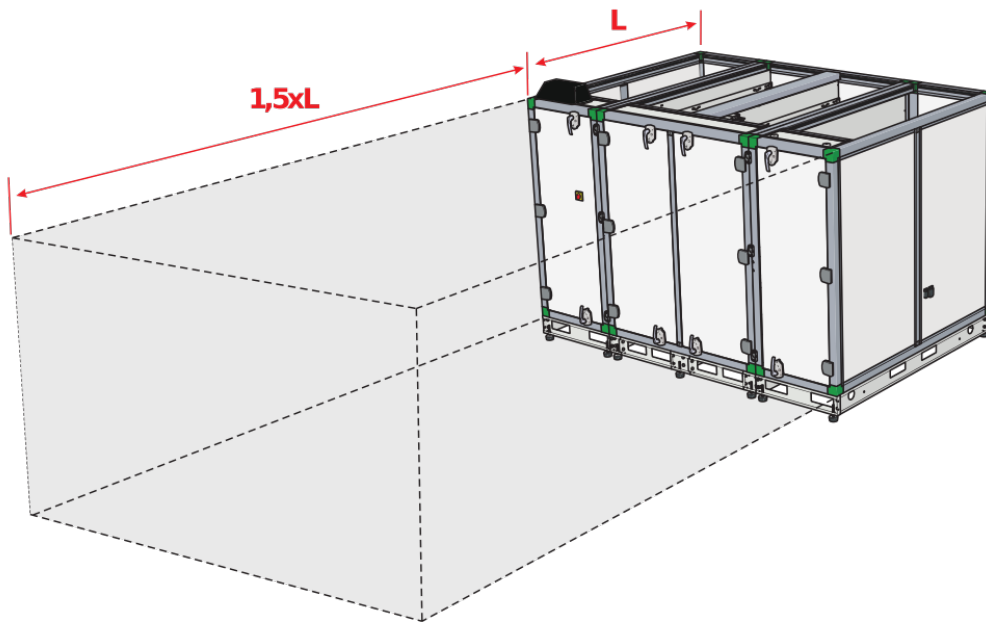
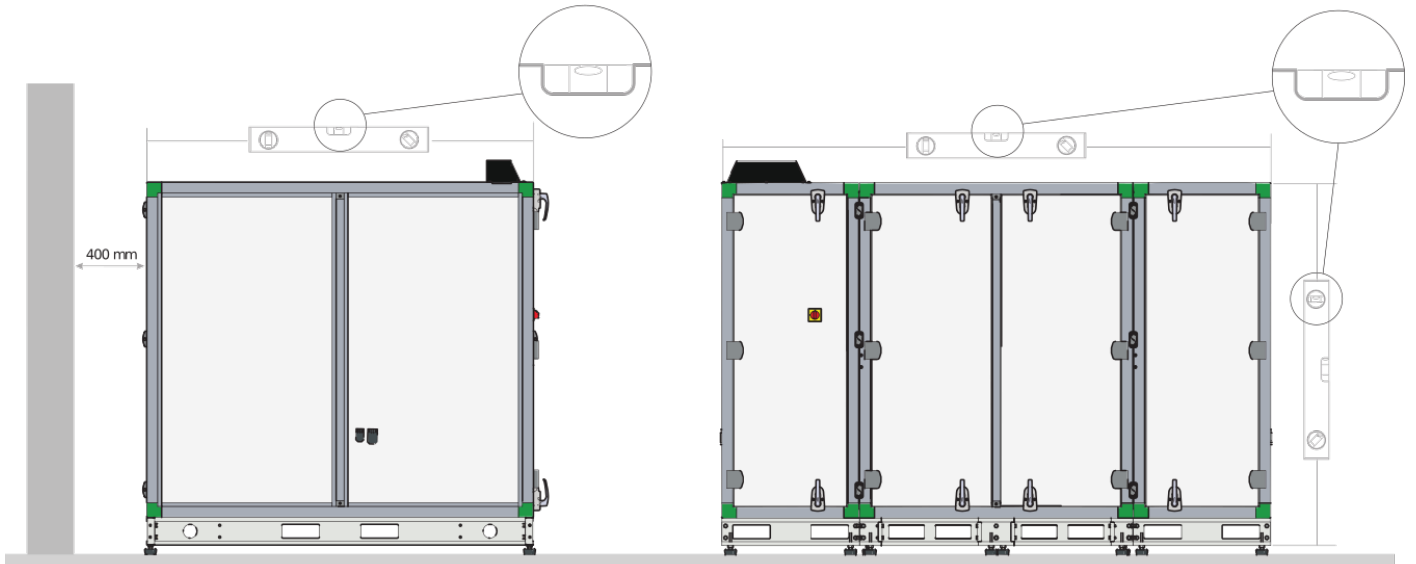

Drainage

- After installing the air handling unit, the condensate drainage system should be connected: connect the siphon (2) (shown at the bottom of the picture) to the condensate trap (1) of the heat recovery unit.
- Two siphons are used at each AmberAir Compact CX V product because two condensate drip trays are installed at each of those units.
- The siphon (2) is connected with the sewage system via a pipe (3), which can be made either of metal, plastic or rubber. It should have a gradient of at least 3° (a metre of the pipe should descent by 55 mm)!
- Prior to starting the recovery unit, the system should be filled with 0.5 litre or more water (the siphon (2) should always be filled up) and make sure that water goes to the sewage system (4)! Otherwise, the room may be flooded when operating the recovery unit!
- The condensate drainage system should be operated in a room with an ambient temperature not below 0 °C! If it may drop below 0 °C, the system must be protected with thermal insulation with additional installation of a heating cable and thermostat.
- The siphon (2) should not necessarily be downstream the recovery unit but below it.
- The legs of AmberAir Compact products of sizes 1-5 CX V are fitted with condensate pipe protection to prevent it from damage when lifted by a forklift. When connecting the condensate drainage system, this protection should be removed (it is a component intended for transportation only).

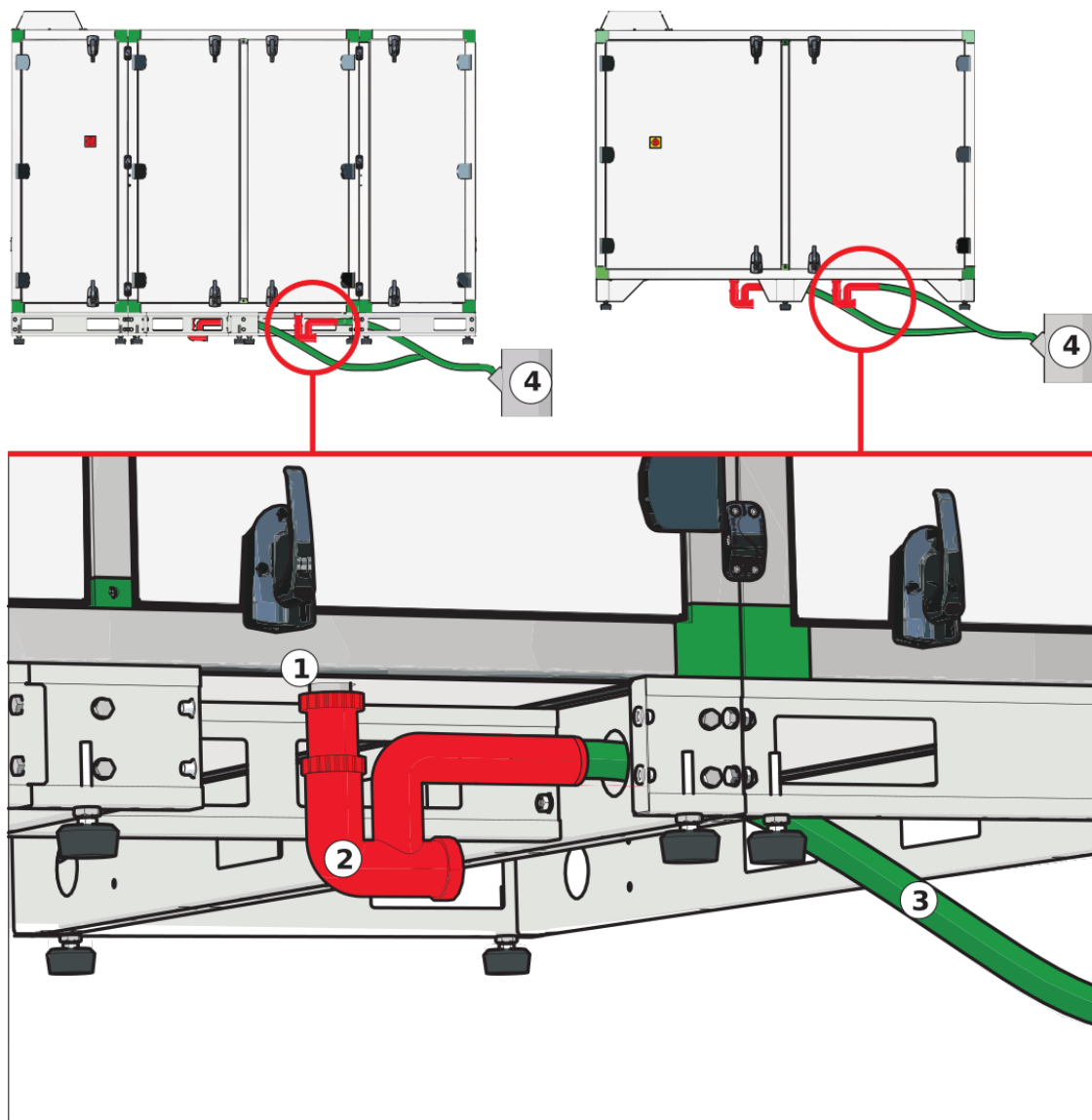

Before every heating season the condensate tube shall be filled with water as indicated during the first startup!

Connection of air ducts

- Connected air ducts must be straight and have their own fixing.
- Make sure that the fans can not be entered through air duct heads. If it is possible to enter the fan, protective grid should be installed. You can choose it in our website.
- Do not reduce the diameter of the piping near air inlet or exhaust ducts. If you want to reduce the speed of air in the system, drop of pressure and noise level, you can increase the diameter.
- In order to reduce the level of the noise in the air supply system, install silencers (see chapter on their installation).
- In order to reduce air loss in the system, the air ducts and profile parts should be of class C and higher. Their catalog can be found in our website.
- Outside air and exhaust system piping should be isolated in order to prevent heat loss and condensation.
- It is recommended to maintain a distance of up to 8 meters between air intake and air exhaust ducts. Air supplying system should be installed further from potential air pollution sources.
- Use holders while installing air ducts next to the ventilation equipment. They suppress vibration and assure a firm installation of various system parts. Necessary holders can be found in our catalog or website.
- A common mistake is that air ducts are attached to improper airflow connection. On the ventilation equipment there are signs, indicating the air duct to be connected. Before starting the system carefully check whether the work was performed properly.

Filter box mounting

Box preparation

- Mount sealing rubbers (II) from the bottom around the flange openings.
- Tighten up the fastening plates (IV) from the end of the box.
- Bend the base eye plates (I) in 4 corners at the bottom of the product using pliers.
- Lift the filter box to mount it on the top of the product using slings.
- Tighten up to the mounting hole (III) using self-tapping screws.
- Connect the filter box to the contamination indicating pressure switches in the product.
- Remove the hose from the end piece 1 and connect it to the end piece 2 (such reconnection is performed at external and exhaust air flanges).

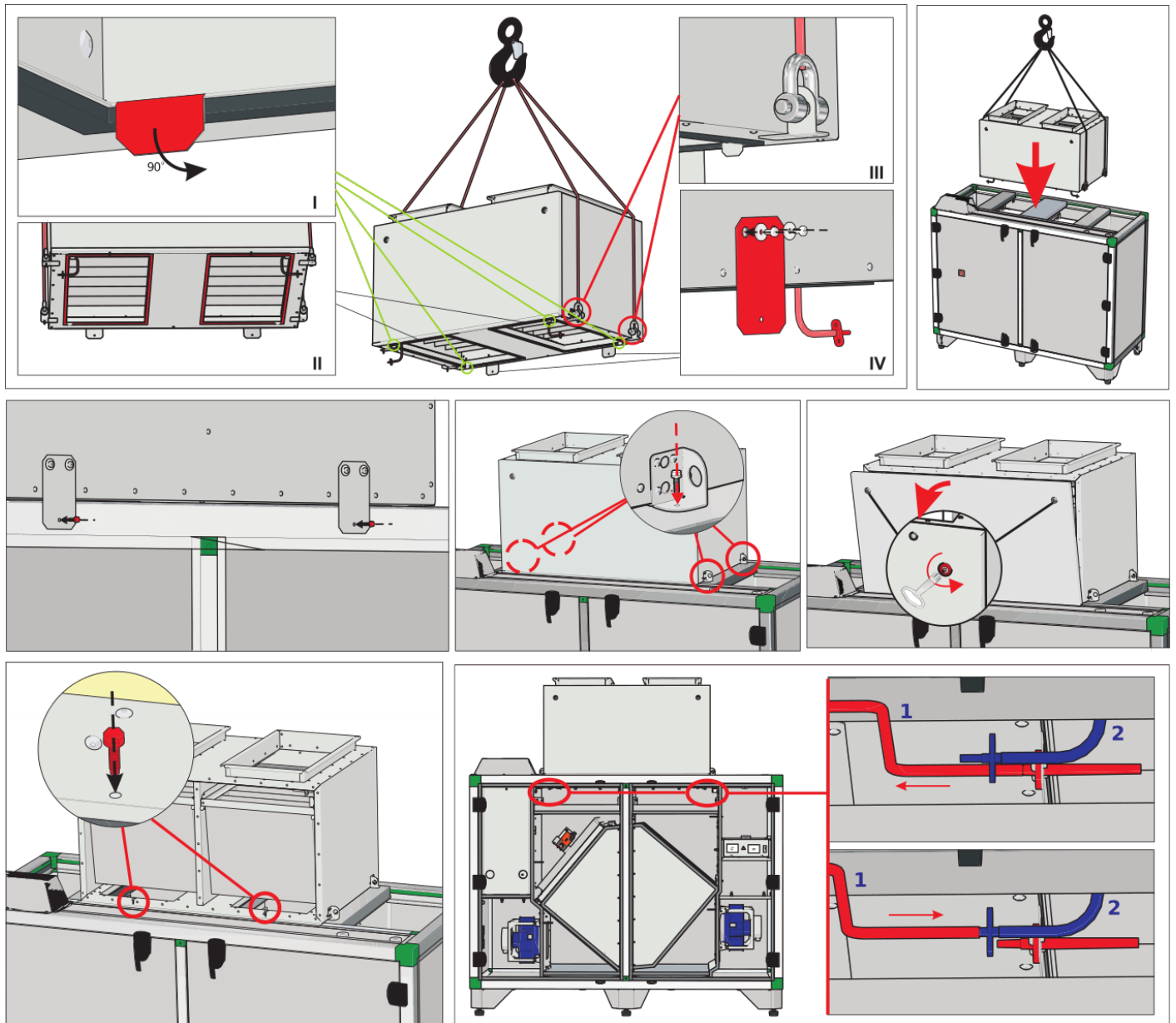

Connection of accessories

Arrangement of controller connections in MCB

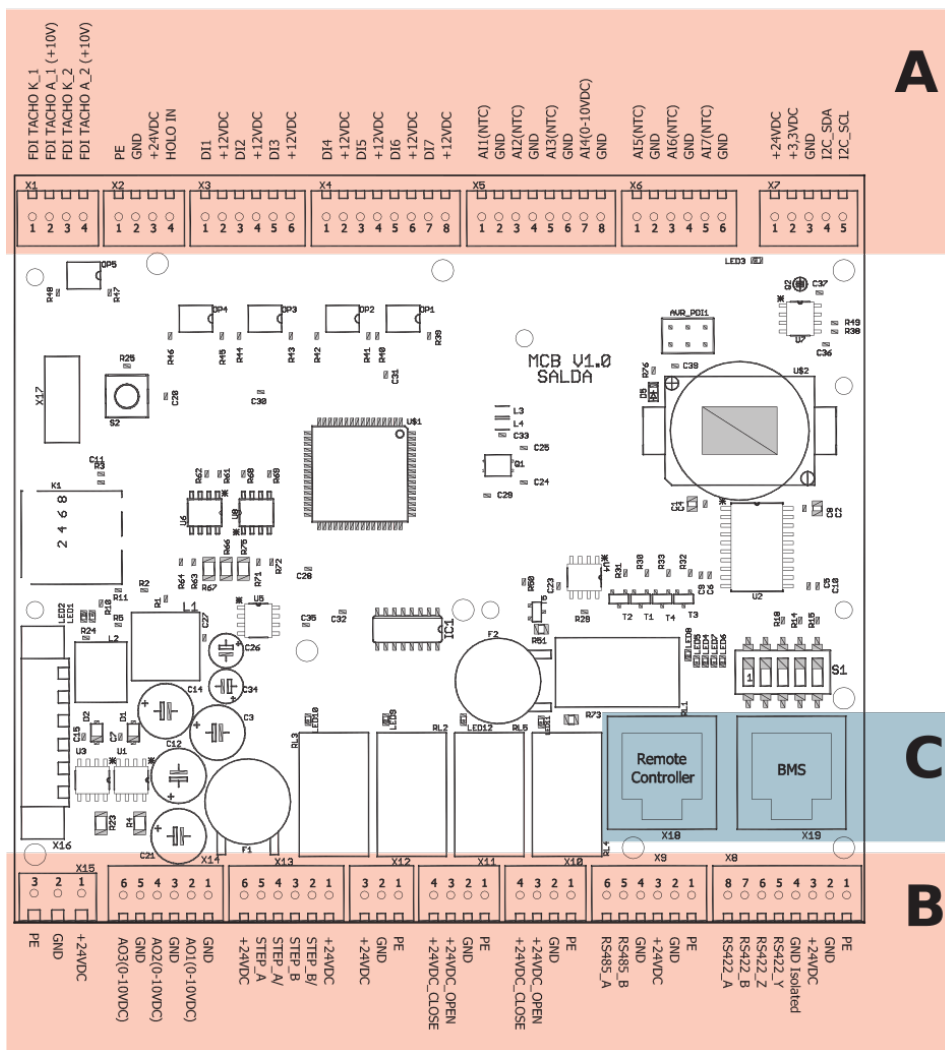
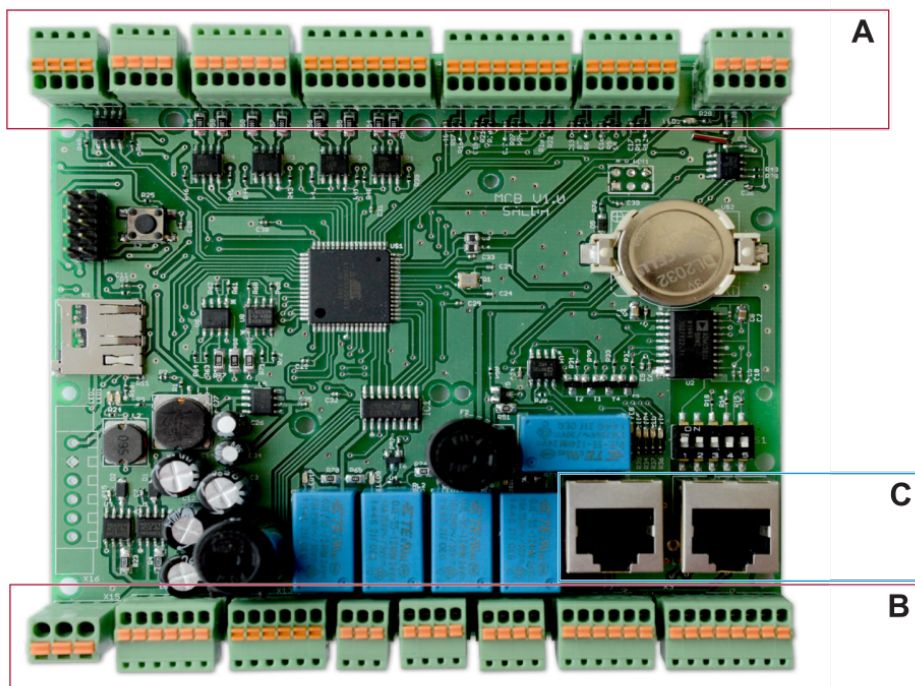

A			
Connector	Contact No.	Contact name	Functional block name
MCB			
X1	1	MCB FDI TACHO K_1(GND)	Supply fan speed RPM
	2	MCB FDI TACHO A_1(+10V)	
	3	MCB FDI TACHO K_2(GND)	Extract fan speed RPM
	4	MCB FDI TACHO A_2(+10V)	
X2	1	PE	Rotor speed RPM
	2	GND	
	3	+24VDC	
	4	MCB HOLO	
X3	1	MCB DI1	Heater automatic protection (NC)
	2	+12VDC	Heater manual protection / Water heater protection - thermostat (NC)
	3	MCB DI2	
	4	+12VDC	
	5	MCB DI3	Supply air fan failure (NC)
	6	+12VDC	
X4	1	MCB DI4	Fire protection input (NC)
	2	+12VDC	By-pass closed (NC)
	3	MCB DI5	
	4	+12VDC	
	5	MCB DI6	Rotor alarm (NC) / Heat exchanger pressure relay (NC).
	6	+12VDC	Extract air fan failure (NC)
	7	MCB DI7	
	8	+12VDC	
X5	1	MCB AI1 (NTC)	Supply air temperature sensor
	2	GND	Outdoor air temperature sensor
	3	MCB AI2 (NTC)	
	4	GND	
	5	MCB AI3 (NTC)	Exhaust air temperature sensor
	6	GND	Heat exchanger pressure transmitter
	7	MCB AI4 (0-10V)	
	8	GND	
X6	1	MCB AI5 (NTC)	Extract air temperature sensor
	2	GND	Reserved
	3	MCB AI6 (NTC)	
	4	GND	
	5	MCB AI7 (NTC)	Hydraulic heater water temperature sensor
	6	GND	
X7	1	+24VDC	Connection with EX2-X47
	2	+3,3VDC	
	3	GND	
	4	I2C_SDA	
	5	I2C_SCL	

B			
Connector	Contact No.	Contact name	Dunctional block name
MCB			
X8	1	PE	BMS connection (RS485; RS422)
	2	GND	
	3	+24VDC	
	4	GND isolated	
	5	RS422_Y	
	6	RS422_Z	
	7	RS422_B	
	8	RS422_A	
X9	1	PE	Remote Control connection (RS485)
	2	GND	
	3	+24VDC	
	4	GND	
	5	RS485_B	
	6	RS485_A	
X10	1	MCB PE	Recirculation actuator control 3P
	2	MCB GND	
	3	MCB RECIRC_+24VDC_OPEN	
	4	MCB RECIRC_+24VDC_CLOSE	
X11	1	MCB PE	By-pass actuator control 3P
	2	MCB GND	
	3	MCB BYPASS_+24VDC_OPEN	
	4	MCB BYPASS_+24VDC_CLOSE	
X12	1	PE	24VDC Power supply for water heater actuator
	2	GND	
	3	+24VDC	
X13	1	+24VDC	By-pass step motor control
	2	STEP_B/	
	3	STEP_B	
	4	STEP_A/	
	5	STEP_A	
	6	+24VDC	
X14	1	GND	Supply air fan control (output 0-10VDC)
	2	MCB AO1(0-10VDC)	
	3	GND	Extract air fan control (output 0-10VDC)
	4	MCB AO2(0-10VDC)	
	5	GND	Electric/Water heater control (output 0-10VDC)
	6	MCB AO3(0-10VDC)	
X15	1	+24VDC	MCB Power supply 24VDC
	2	GND	
	3	PE	
C			
Connector	Contact No.	Contact name	Dunctional block name
MCB			
X18			Remote Control connection (RS485)
X19			BMS connection (galvanically isolated RS485 or RS422, configurable via SL1)

Arrangement of controller connections in EX1

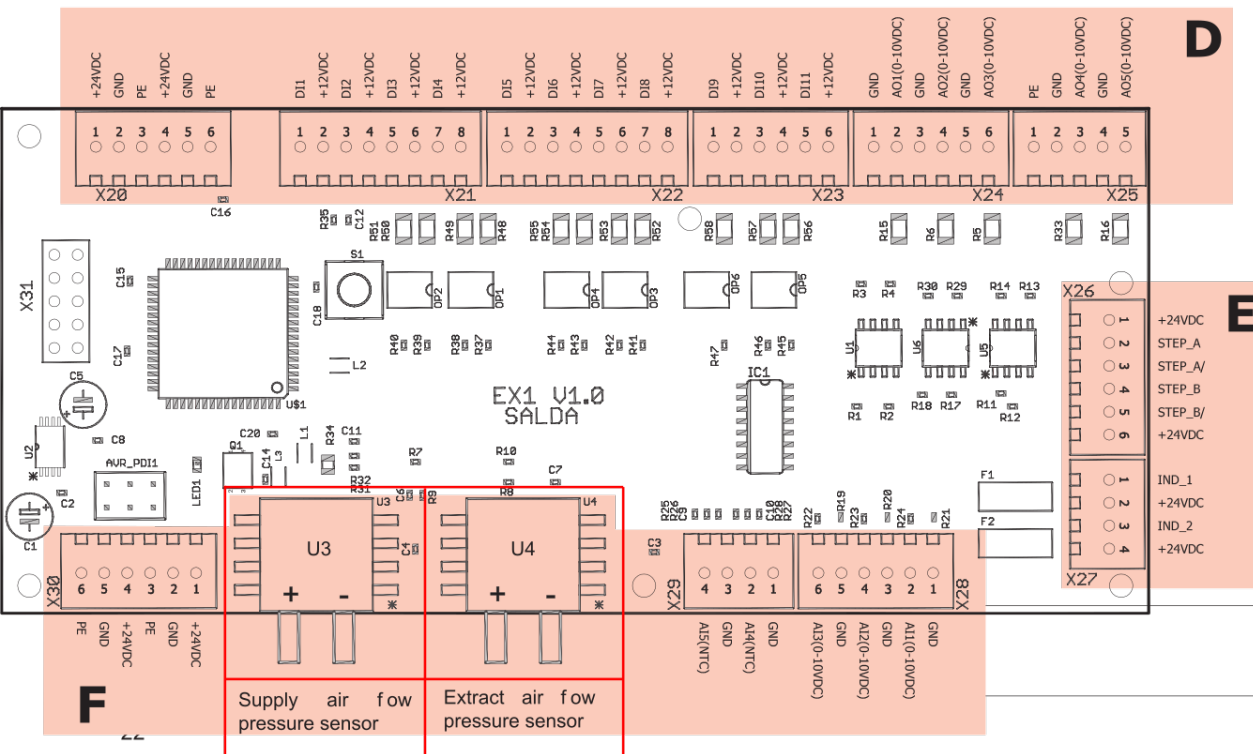
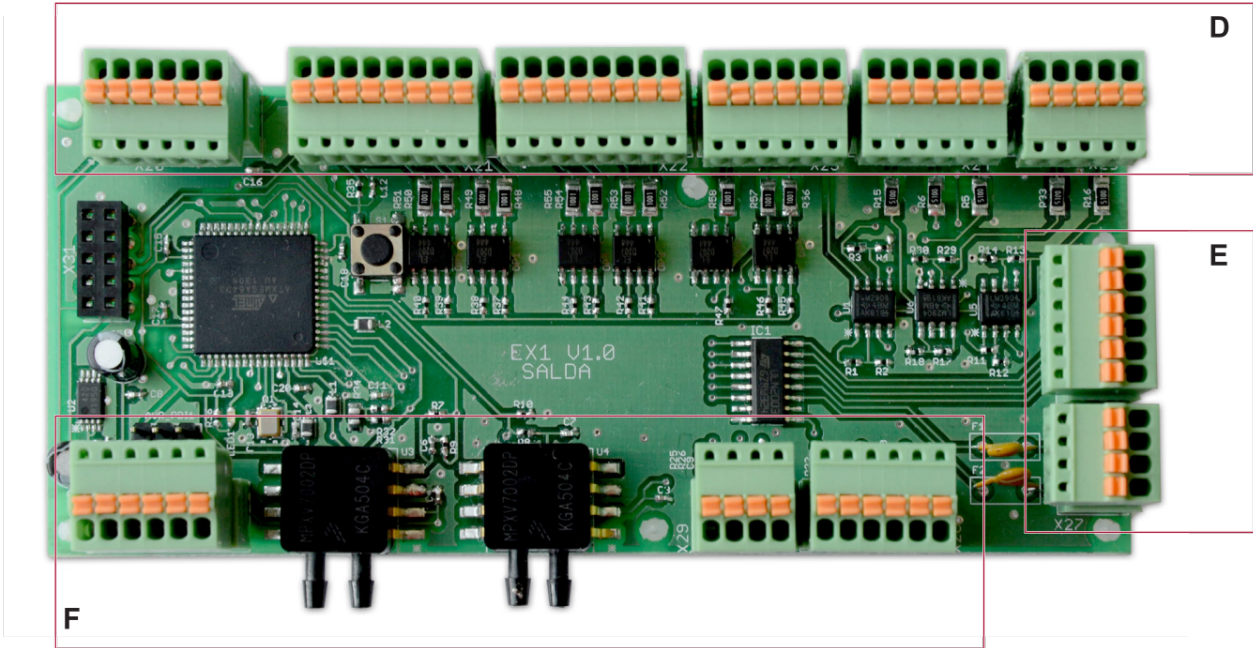

E			
Connector	Contact No.	Contact name	Dunctional block name
MCB			
X20	1	+24VDC	24VDC Power supply for water preheater actuator
	2	GND	
	3	PE	
	4	+24VDC	24VDC Power supply for water cooler actuator
	5	GND	
	6	PE	
X21	1	DI1	Electric Preheater automatic protection (NC) / DX cooler deicing
	2	+12VDC	
	3	DI2	Electric Preheater manual protection (NC)
	4	+12VDC	
	5	DI3	System mode switch (Start/Stop)
	6	+12VDC	
	7	DI4	Fans speed switch (Boost)
	8	+12VDC	
X22	1	DI5	DX cooler failure (NC)
	2	+12VDC	
	3	DI6	Supply air filter pressure switch (NO)
	4	+12VDC	
	5	DI7	Extract air filter pressure switch (NO)
	6	+12VDC	
	5	DI8	Fire place protection (NC)
	6	+12VDC	
X23	1	DI9	Fire damper opened (NC)
	2	+12VDC	
	3	DI10	Fire damper closed (NC)
	4	+12VDC	
	5	DI11	Recirculation damper closed (NC)
	6	+12VDC	
X24	1	GND	Electric/Water preheater control (0-10VDC) (output 0-10VDC)
	2	AO1(0-10VDC)	
	3	GND	DX cooler control (output 0-10VDC)
	4	AO2(0-10VDC)	
	5	GND	Water cooler control (output 0-10VDC)
	6	AO3(0-10VDC)	
X25	1	PE	Recirculation actuator control (output 0-10VDC) (išvestis 0-10VDC)
	2	GND	
	3	AO4(0-10VDC)	
	4	GND	Rotor control / By-pass actuator control (output 0-10VDC)
	5	AO5(0-10VDC)	
D			
Connector	Contact No.	Contact name	Dunctional block name
EX1			
X26	1	+24VDC	Recirculation step motor control
	2	STEP_A	
	3	STEP_A/	
	4	STEP_B	
	5	STEP_B/	
	6	+24VDC	

X27	1	IND_1	Working indication output (START). 24VDC; max 50mA, 1.2W.
	2	+24VDC	
	3	IND_2	Alarm indication output (STOP). 24VDC; max 50mA, 1.2W.
	4	+24VDC	
F			
Connector	Contact No.	Contact name	Functional block name
EX1			
X28	1	GND	Supply/Extract air co ₂ /RH (input 0-10VDC)
	2	AI1 (0-10V)	
	3	GND	Supply/Extract air co ₂ /RH (input 0-10VDC)
	4	AI2 (0-10V)	
	5	GND	Reserved (input 0-10VDC)
	6	AI3 (0-10V)	
X29	1	GND	Water cooler temperature sensor
	2	AI4 (NTC)	
	3	GND	Hydraulic preheater water temperature
	4	AI5 (NTC)	
X30	1	+24VDC	24VDC Power supply for Air quality transmitter I
	2	GND	
	3	PE	
	4	+24VDC	24VDC Power supply for Air quality transmitter II
	5	GND	
	6	PE	
U3		SUP_PRESS	Current supply air flow pressure (Pa)
U4		EXT_PRESS	Current extract air flow pressure (Pa)

Arrangement of controller connections in EX2

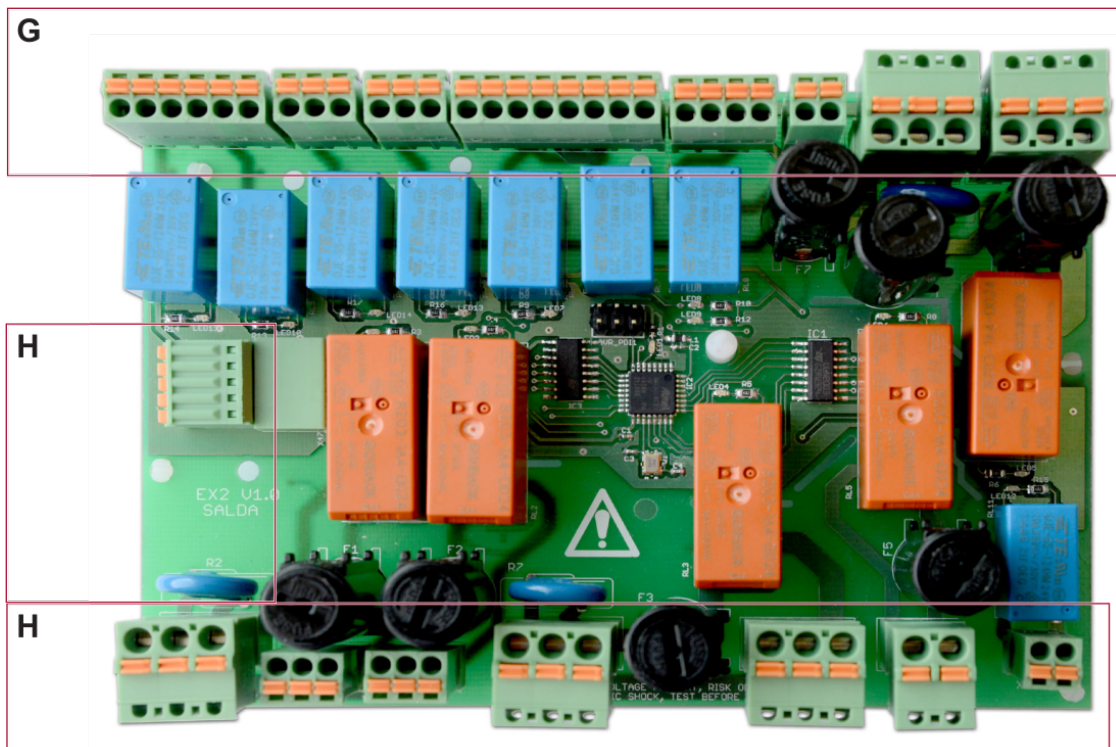

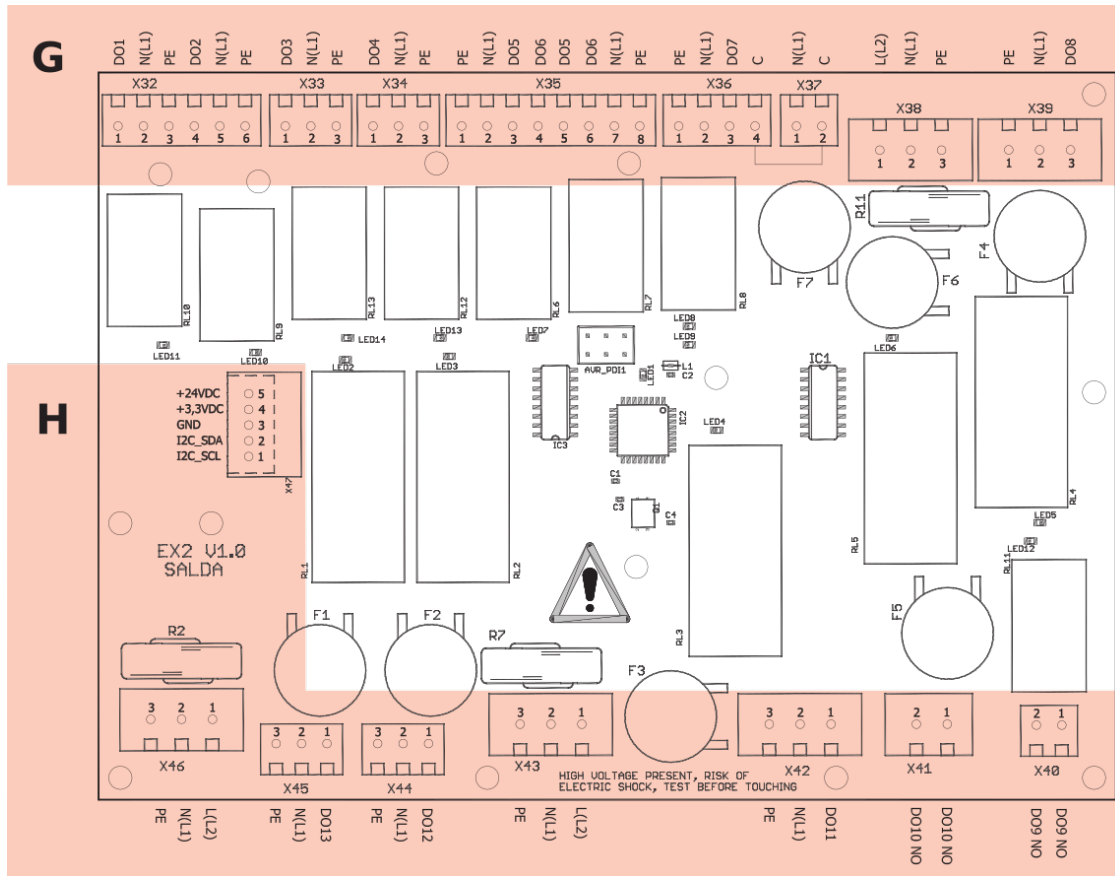

G			
Connector	Contact No.	Contact name	Dunctional block name
EX2			
X32	1	DO1	Power supply for Fire damper actuator 1, max 100 mA
	2	N(L1)	
	3	PE	
	4	DO2	Power supply for Fire damper actuator 2, max 100 mA
	5	N(L1)	
	6	PE	
X33	1	DO3	Water cooler circulation pump
	2	N(L1)	
	3	PE	
X34	1	DO4	Control box heater control or Control box ventilation fan control
	2	N(L1)	
	3	PE	
X35	1	PE	Supply/extract air damper control DO5 (Open) DO6 (Close)
	2	N(L1)	
	3	DO5	
	4	DO6	
	5	DO5	
	6	DO6	
	7	N(L1)	
	8	PE	

X36	1	PE	Rotor motor control
	2	N(L1)	
	3	DO7	
	4	C - capacitor	
X37	1	N(L1)	
	2	C - capacitor	
X38	1	N(L2)	230VAC Power supply for X32, X33, X34, X35, X36 and X39
	2	N(L1)	
	3	PE	
X39	1	PE	Electric/Water Heater power line/circulation pump
	2	N(L1)	
	3	DO8	
H			
Connector	Contact No.	Contact name	Functional block name
EX2			
X40	1	DO9 NO	DX cooler reverse (NO-cooling; NC-heating)
	2	DO9 NO	
X41	1	DO10 NO	DX cooler power line
	2	DO10 NO	
X42	1	DO11	Preheater power line/circulation pump
	2	N(L1)	
	3	PE	
X43	1	L (L2)	230VAC Power supply for X42
	2	N (L1)	
	3	PE	
X44	1	DO12	Extract fans power line (IV vent. Max 3,5 A)
	2	N(L1)	
	3	PE	
X45	1	DO13	Supply fans power line (PV vent. Max 3,5 A)
	2	N(L1)	
	3	PE	
X46	1	N(L2)	230VAC Power supply for X44 and X45
	2	N(L1)	
	3	PE	
X47	1	+24VDC	Connection with MCB-X7
	2	+3,3VDC	
	3	GND	
	4	I2C_SDA	
	5	I2C_SCL	

Abbreviation in electrical circuit diagrams

Abbreviation	Explanation
CB	Control board
UC	Components to be connected by the user
N1	MCB control board
N2	EX1 control board
N3	EX2 control board
Q5	Electrical pre-heater power supply circuit breaker
K3	Electrical pre-heater contact
PE1	Electric pre-heater
A1	Fire alarm damper actuator I (supply air)
A2	Fire alarm damper actuator I (exhaust air)
K5	Fire alarm damper I open
K6	Fire alarm damper I closed
K7	Fire alarm damper II open
K8	Fire alarm damper II closed
M2	Supply air damper
M3	Exhaust air damper
FA	Fire alarm
FPP	Fireplace protection
START	Operation indicator
START	Warning indicator
System mode switch	System mode switch (START/STOP)
Fan speed switch	Fan speed switch (BOOST)
M4	Water heater circulation pump
M6	Water heating indicator output 0-10VDC
T1	Water heater protection thermostat
T2	Cooling switching thermostat
TV	Water heater temperature sensor
M12	Water heater control output 0-10VDC
TV2	Water heater temperature sensor
M16	Water heater circulation pump
TV3	Water cooler temperature sensor
M13	Water cooler control output 0-10VDC
M14	Water cooler circulation pump
M15	DX cooler control output 0-10VDC
K4	DX cooler error
X40 [1:2]	DX cooler reserve mode (NO - cooling / NC - heating)
X41 [1:2]	DX cooler power supply
Transmitter1	Exhaust air RH sensor
Transmitter2	Exhaust air CO ₂ sensor

Electrical external pre-heater

+UC

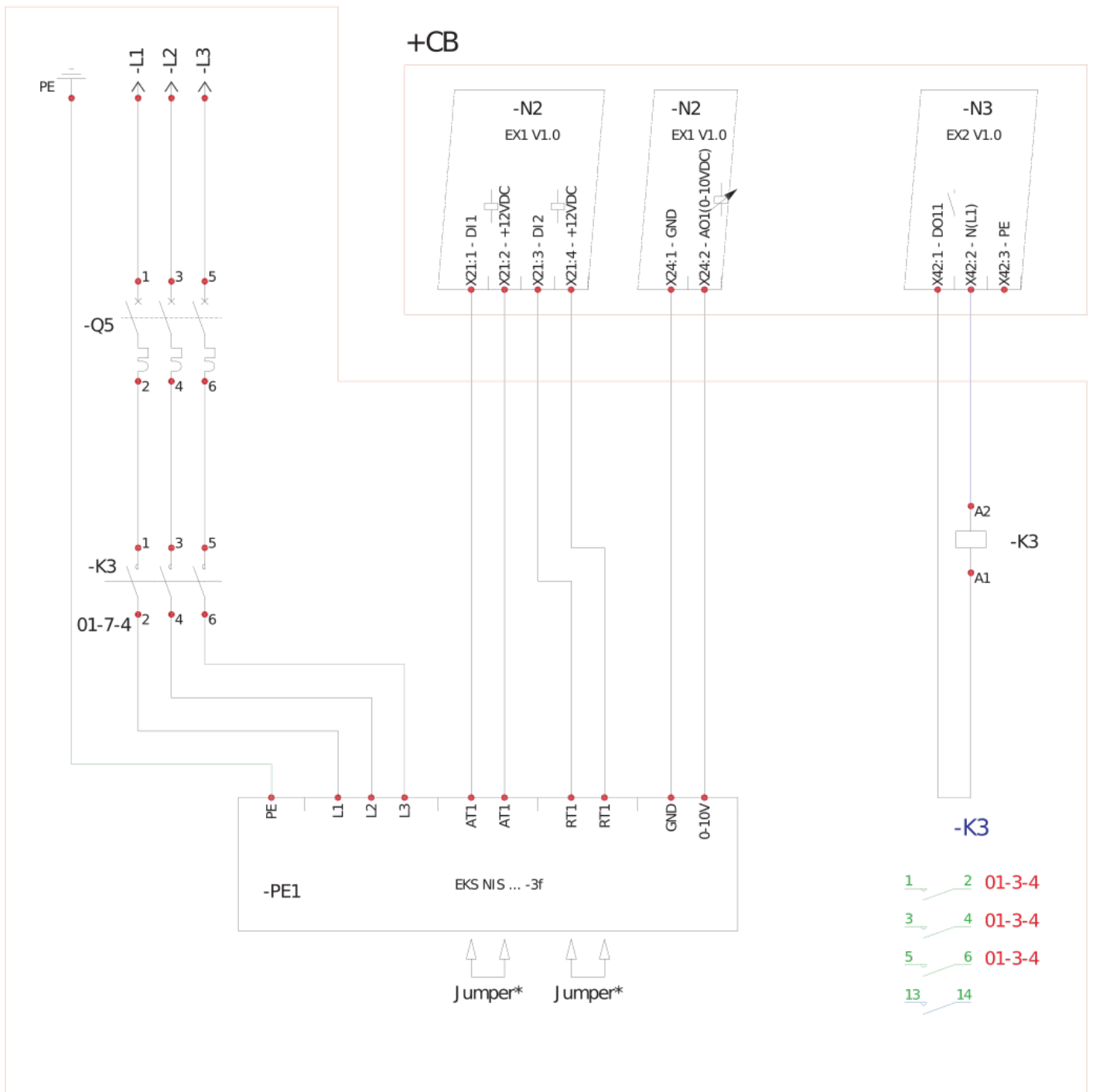

External water pre-heater

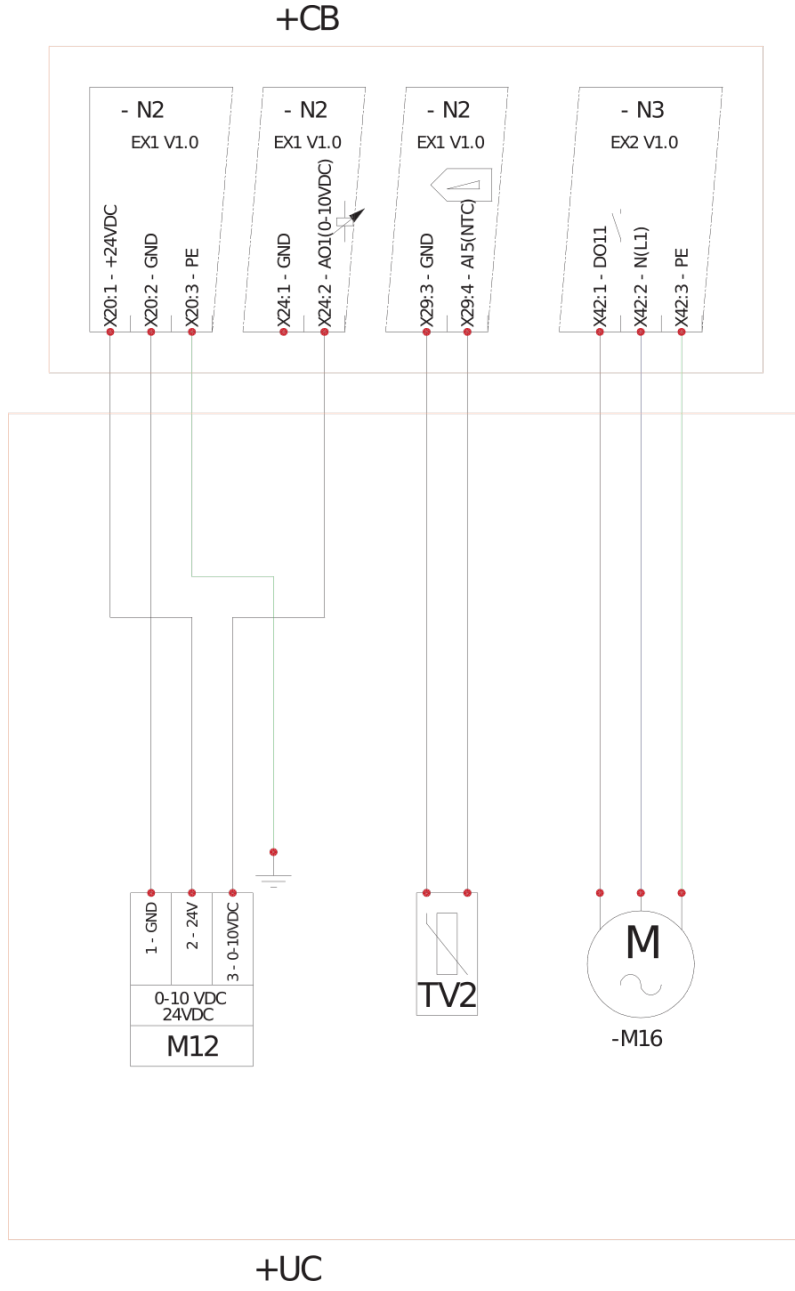

External water cooler

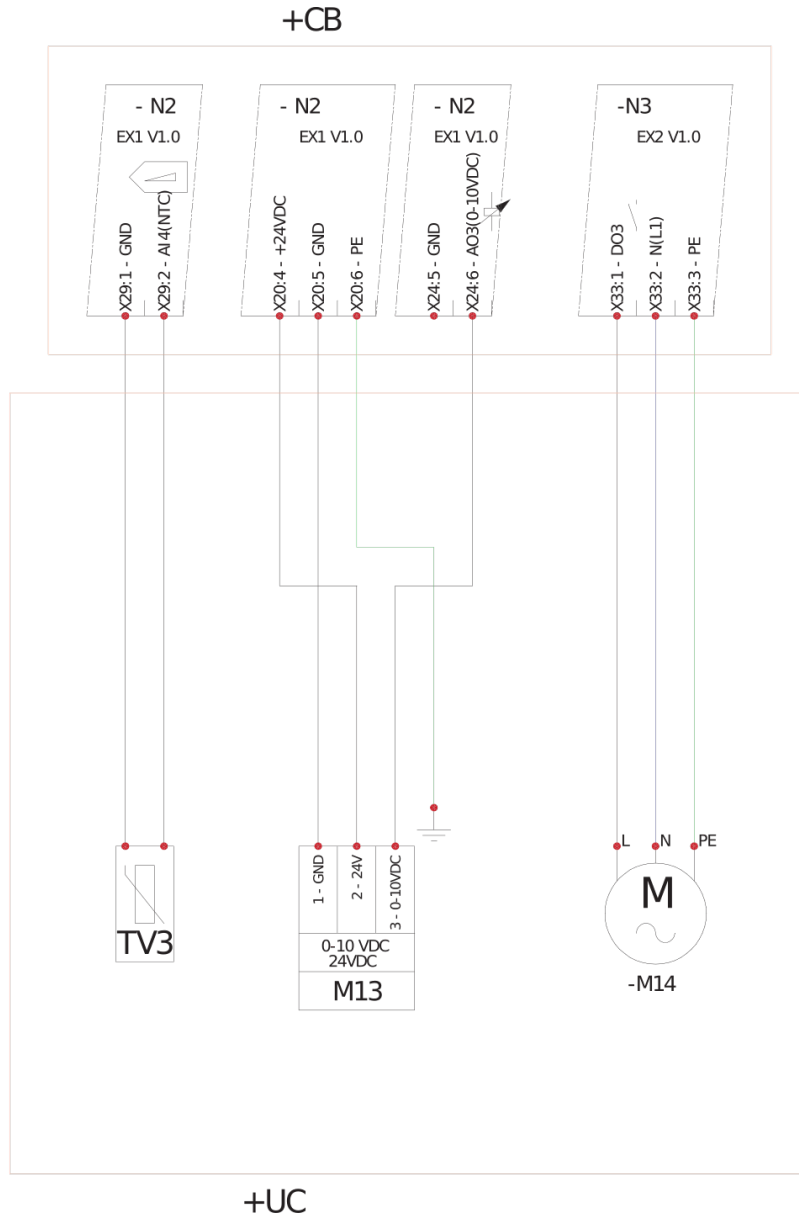

External DX cooler

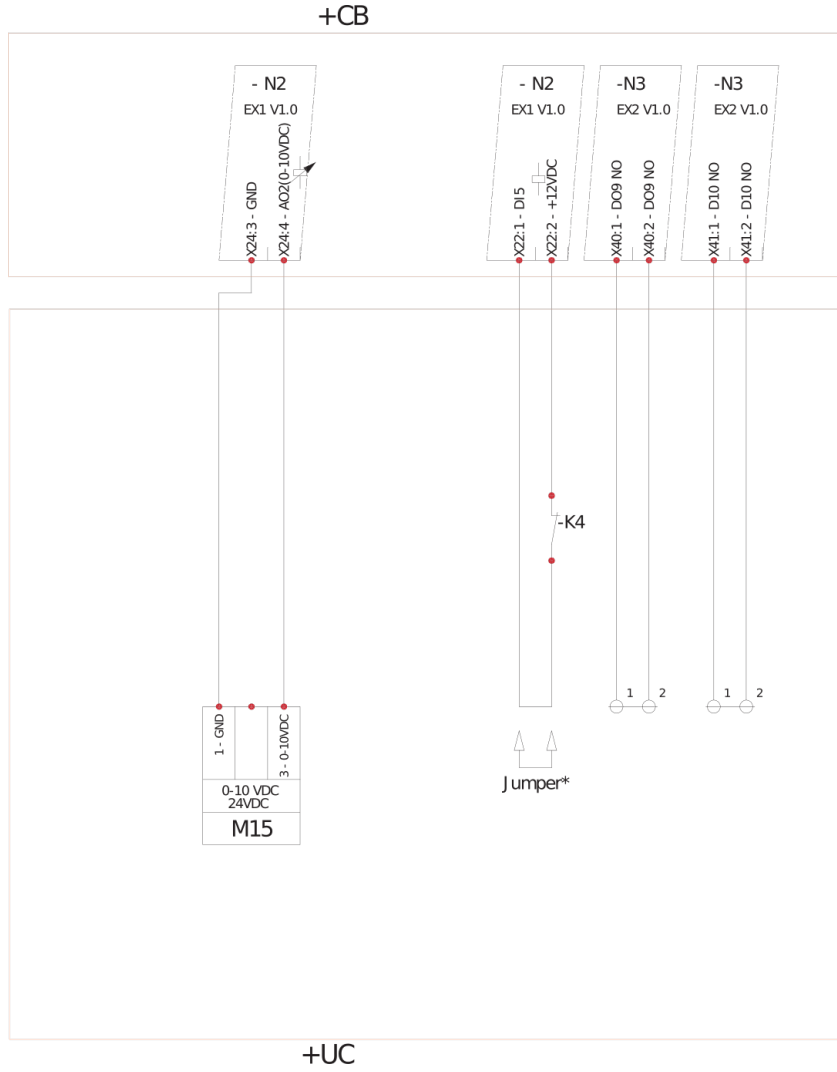

Fire protection connection

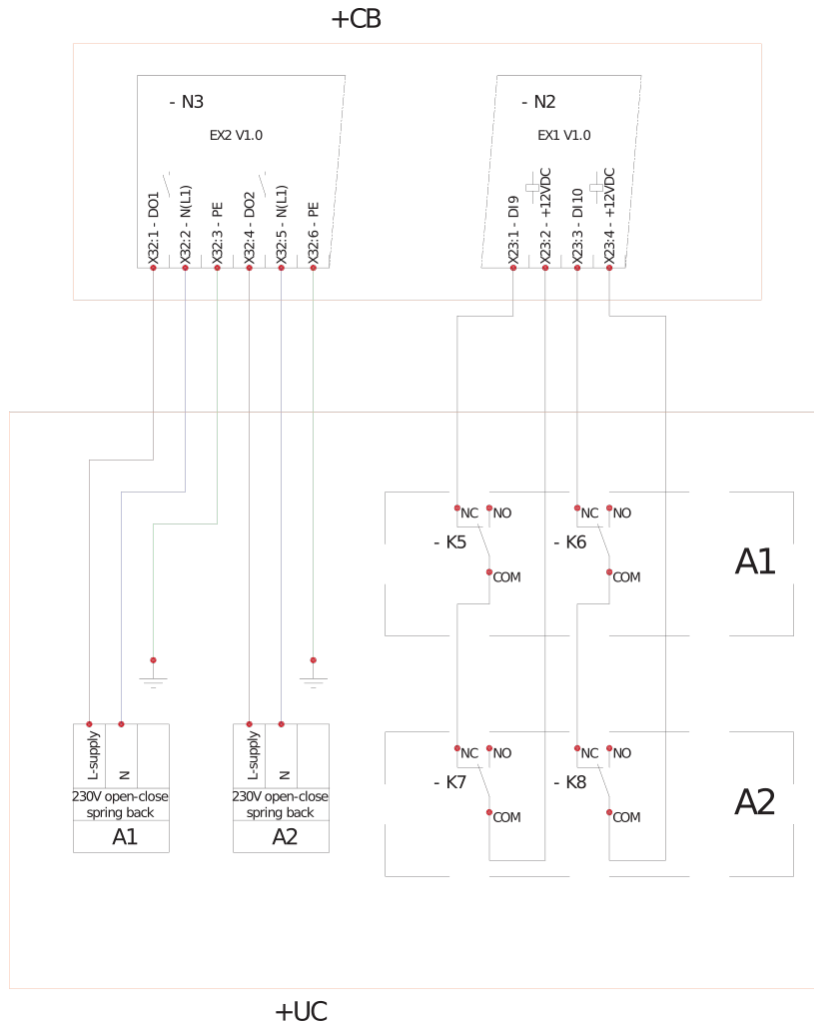

Motorised air dampers

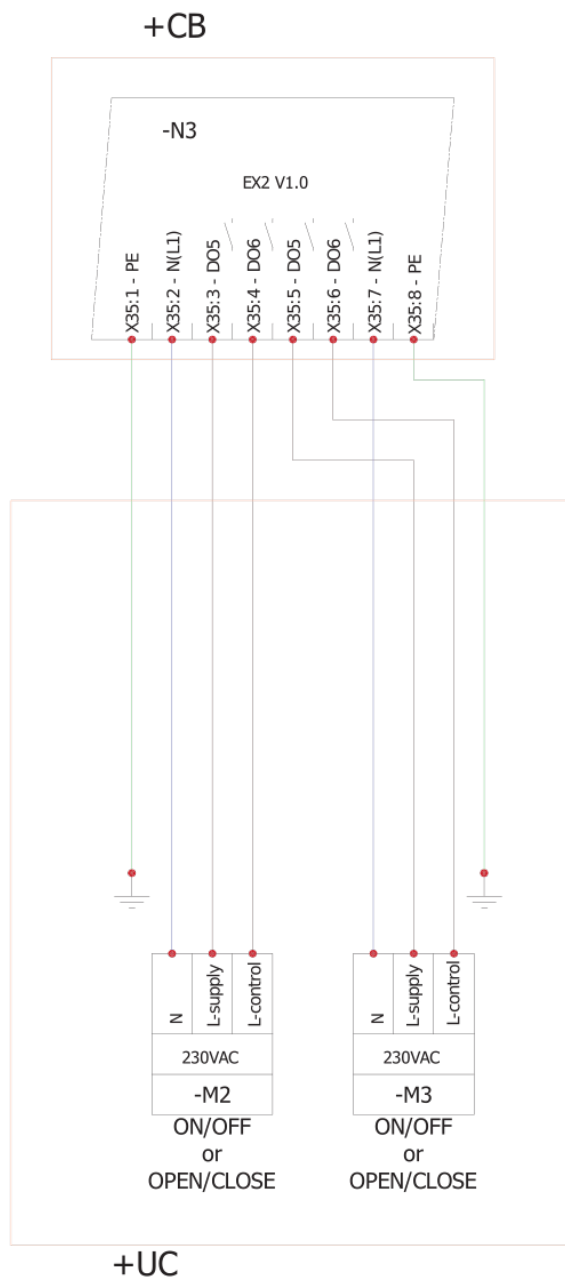
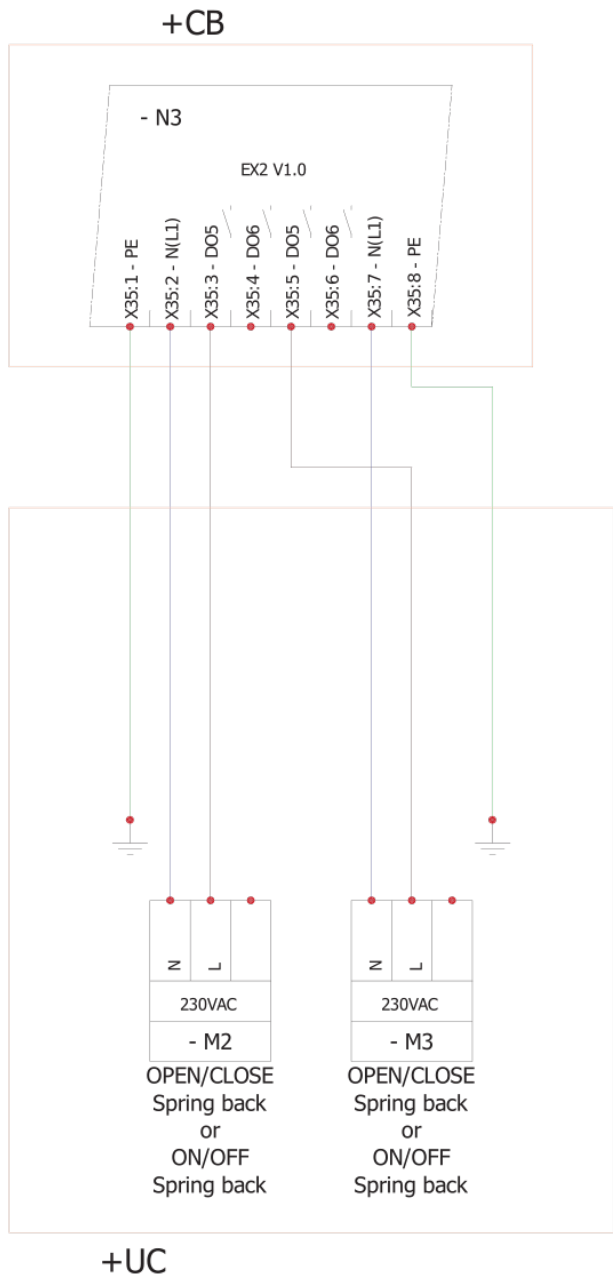

CO₂ arba RH sensors

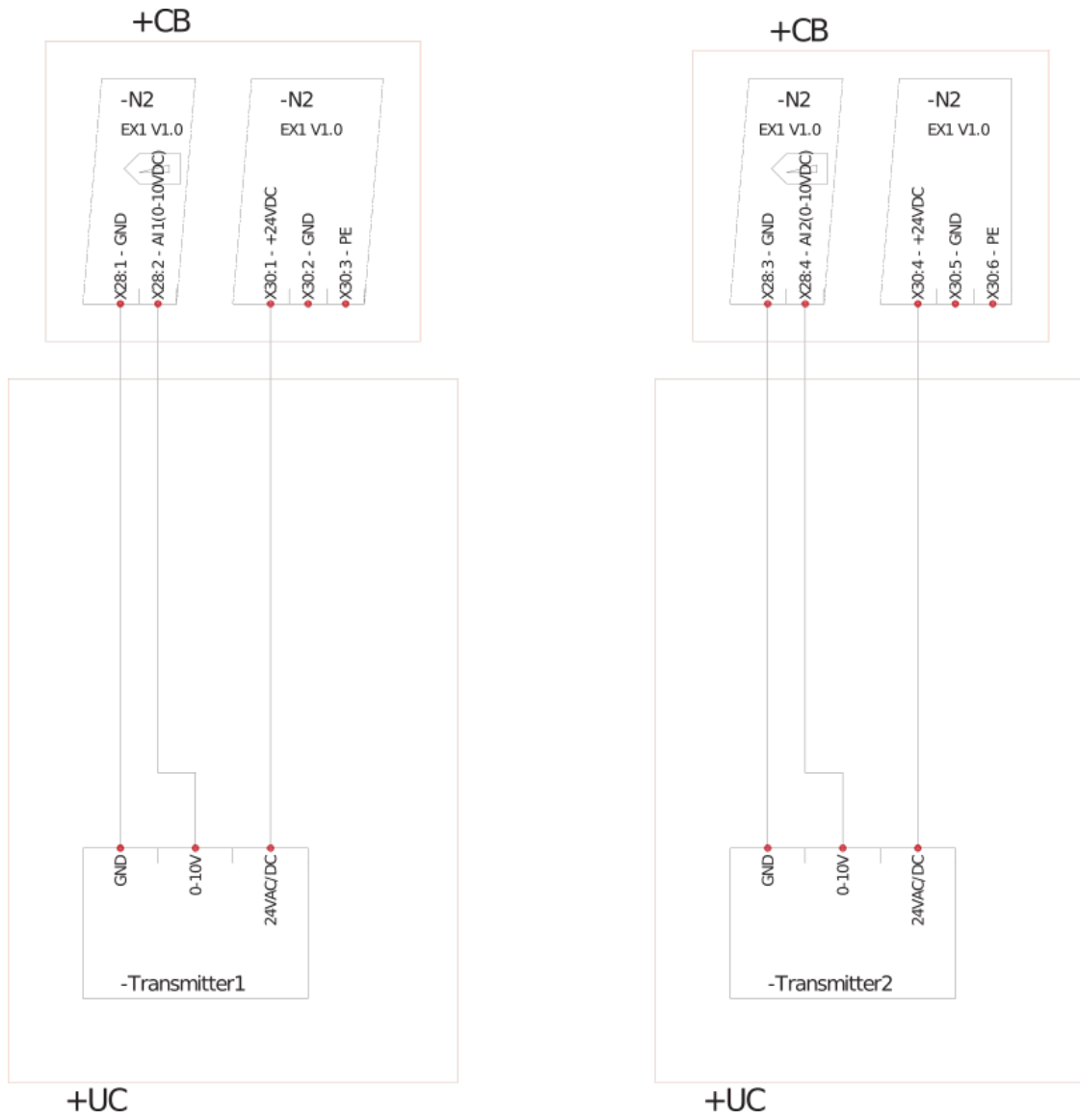

Unit status indication / mode change / fire alarm inlet / fireplace function input

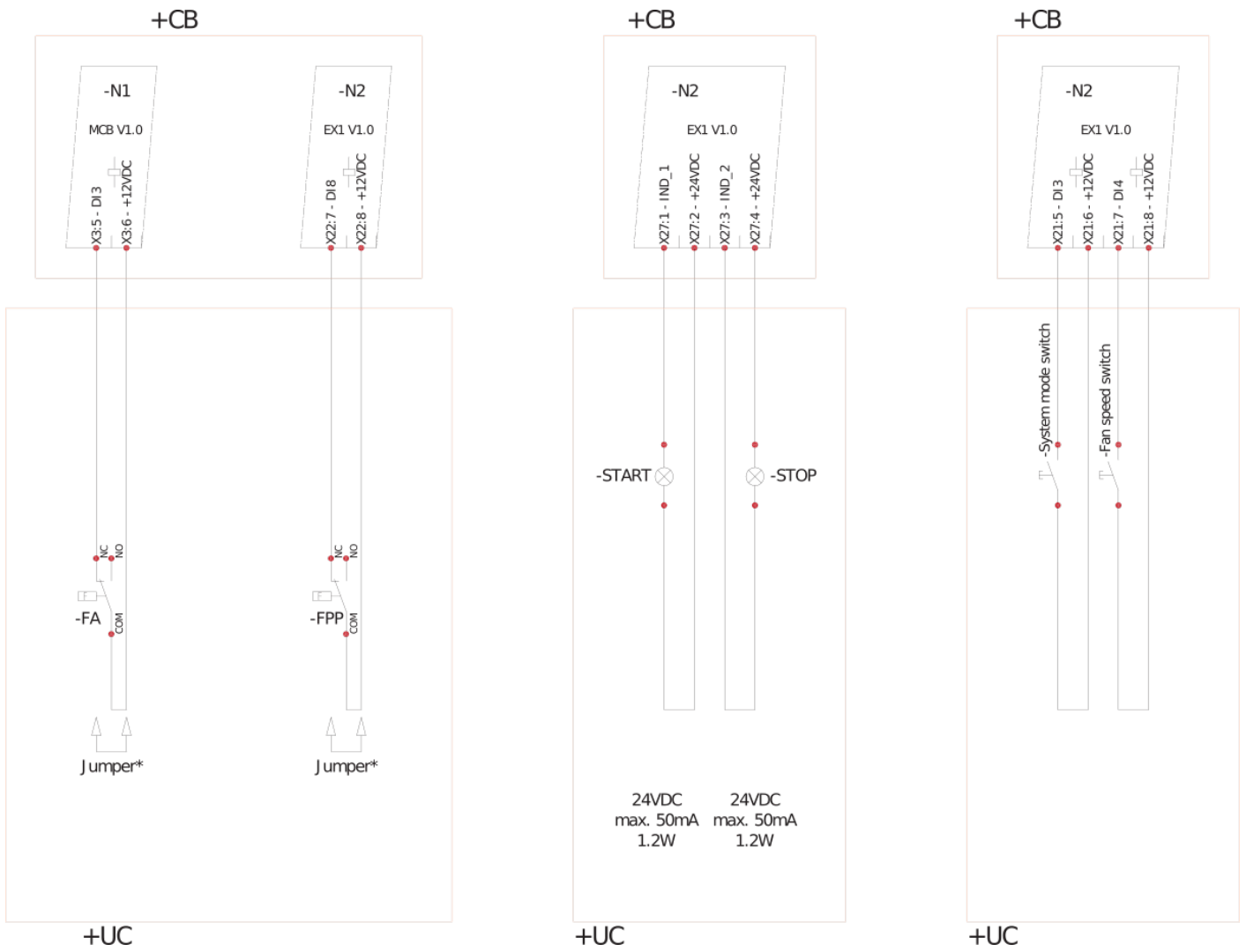

*The jumpers are installed by the manufacturer (see on the automatics switchboard).

*All the external electrical connections must be made in accordance with effective legal acts and safety requirements.

*The configuration and control of accessories is presented in the section "Functions" of this Certificate.

Connection of the unit to electric network

- Supply voltage to the unit must be connected by a qualified specialist following the manufacturer's instructions and effective safety instructions.
- The unit's power network voltage must correspond to electrotechnical parameters of the unit indicated in the technical decal.
- The unit's voltage, power and other technical parameters are provided in the unit's technical decal (on the unit casing). The unit must be connected to the voltage plug socket of the grounded power network in compliance with the effective requirements.
- The unit must be earthed according to the rules on installing electrical equipment.
- It is prohibited to use extension wires (cables) and power network plug socket distribution devices.
- Prior to carrying out any ventilation unit installation and connection activities (until its hand-over to the customer), the unit must be disconnected from the power network.
- After installation of the ventilation unit, the power network plug socket must be accessible at any time and disconnection from the power network is performed through the two-pole circuit breaker (by disconnecting phase pole and neutral).
- The unit must be thoroughly checked against damages (execution, control, measurement nodes) during transportation before it is connected to the power network.
- The power cable can be replaced only by a qualified specialist upon the evaluation of the rated power and current.



The manufacturer does not assume any liability for personal injuries and property damage due to nonconformance with the provided instructions.

Start-up recommendations

System protection

The control automatics of the unit have integrated protection against a short circuit of those assemblies. The controllers have the following protectors:

MCB
F1, F2 - 1A(5x20) MCB protection;

EX2
to change depending on the product



To ensure safe maintenance of the unit, it is necessary to remove the plug from the power network.

Recommendations before the start of the unit (before the final user)

Prior to start-up the system must be thoroughly cleaned. Check whether:

- operation systems and unit elements as well as automation and automation devices were not damaged during installation,
- all electrical devices are connected to power supply and fit for service,
- all necessary automation elements are installed and connected to power supply and MCB, EX1, EX2 terminal blocks,
- cable connection to MCB, EX1, EX2 terminal blocks comply with the existing power connection diagrams,
- all electrical equipment protection elements are properly connected (if they are additionally used),
- cables and wires correspond to all applicable safety and functional requirements, diameters, etc.,
- earthing and protection systems are properly installed,
- condition of all seals and sealing surfaces is proper.

Possible faults and troubleshooting

Failure	Cause	Explanation / corrective actions
Unit is not operating	No supply voltage	Check whether the device is connected to the plug socket
	Two-pole protection device is off or a current leakage relay is active (if installed by the installer)	Switch on only if the unit condition has been evaluated by a qualified electrician. If the system failed, the failure MUST BE rectified prior to switching it on.
Air supply heater or pre-heater is not operating or malfunctioning (if installed)	Too low air flow in air ducts activates automatic protection	Check if air filters are not clogged Check if fans are rotating
	Manual protection is activated	Possible heater or unit failure. MUST address the servicing staff for failure detection and its elimination.
Too low air flow at rated fan speed	Clogged supply and/or extract air filter(s)	Filter replacement needed
Filters are clogged and no message is shown on the remote control	Wrong time in filter timers or their switch is broken, or its pressure is set improperly.	Shorten filter timer time till the message of clogged filters or replace the pressure switch of the filters, or set their proper pressure.

Improvements and changes to this manual necessitated by typographical errors, inaccuracies of current information, or improvements to programs and/or equipment, may be made by the manufacturer at any time and without notice. Such changes will, however, be incorporated into new editions of this manual. All illustrations are for illustrative purposes only and may not accurately depict the actual device.



Declaration of conformity

Manufacturer:

SALDA UAB
Ragainės g. 100
LT-78109 Šiauliai, Lithuania
Tel.: +370 41 540415
www.salda.lt

Hereby confirms that the following products - Air handling units:

AmberAir Compact SD50+*; AmberAir Compact CD50*

(where by „*“ indicates possible unit design size and modification)

Provided it was delivered and installed in the facility in accordance with the included installation instructions, comply with all applicable requirements in the following directives:

Machinery Directive 2006/42/EC
EMC Directive 2014/30/EU
Ecodesign Directive 2009/125/EC

The following harmonized standards are applied in applicable parts:

LST EN ISO 12100:2011 - Safety of machinery - General principles for design - Risk assessment and risk reduction.
LST EN 60204-1:2006 - Safety of machinery - Electrical equipment of machines - Part 1: General requirements.
LST EN 60335-1:2012 - Household and similar electrical appliances. Safety. Part 1: General requirements.
LST EN 60529:1999 - Degrees of protection provided by enclosures (IP code).
LST EN 61000-6-2:2005 - Electromagnetic compatibility (EMC) - Part 6-2: Generic standards - Immunity for industrial environments.
LST EN 61000-6-3:2007 - Electromagnetic compatibility (EMC) - Part 6-3: Generic standards - Emission standard for residential, commercial and light-industrial environments.

Should any alterations be made in the products, this declaration will no longer apply.

Notified body: VšĮ Technikos priežiūros tarnyba, Naugarduko g. 41, LT – 03227 Vilnius, Lithuania, identification number 1399.

Quality: Salda UAB activities are in line with the international quality management system standard ISO 9001:2015.

Data 2017-02-07

A handwritten signature in black ink, consisting of a stylized, cursive script that appears to be the name "Darius Buožinis".

Darius Buožinis
Director product development

SALDA UAB, Ragainės g. 100, LT-78109 Šiauliai; tlf.: +370 41 540415, fax: +370 41 540417; e-mail: office@salda.lt
Company code: LT244114580, VAT code: LT441145811, Beneficiary's bank: "Swedbank" AB, LT, Acc. No: LT467300010000065770,
Swift: HABALT22, Bank code: 73000, Correspondent bank: Deutsche bank AG, Frankfurt, Swift: DEUTDEFF, BLZ 500 700 10



Declared typology		NRVU/BVU
Type of drive		Variable
Type of HRS		Plate heat exchanger
Thermal efficiency of heat recovery	[%]	84
Nominal NRVU flow rate	[m ³ /s]	0.83
Effective electric power input	[kW]	2.23
SFPint	[W/(m ³ /s)]	1379
Face velocity	[m/s]	1.90
Normal external pressure	[Pa]	250
Internal pressure drop of ventilation components	[Pa]	433 / 370
Static efficiency of fans used in accordance with Regulation No 327/2011	[%]	58.0
Declared maximum external leakage	[%]	<1
Declared maximum internal leakage	[%]	<1
Energy classification of the filters		D
Description of visual filter warning		Pressure controlled
Casing sound power level (Lwa)	[dB(A)]	63
Internet address for disassembly instructions		www.salda.it

Information requirements for NRVUs (EU 1253/2014).