

R-AQUA

Lucht/water warmtepompen

1. Meegeleverde kabels.
2. Aansluitschema's.

1) Communicatiekabel:
CN3 (Binnenunit) -> CN 12 (Buitenunit)
Zie gele markeringen op de circuit
diagram van de binnen- en buitenunit



2) Temperatuursensor watertank:
CN9 (Binnenunit)
Zie de groene markeringen op het
circuit diagram van de binnenunit.



3) Kabel voor ruimtetemperatuursensor:
CN8 (Binnenunit) + ruimtetemperatuursensor
Zie de groene markeringen op het circuit
diagram van de binnenunit.

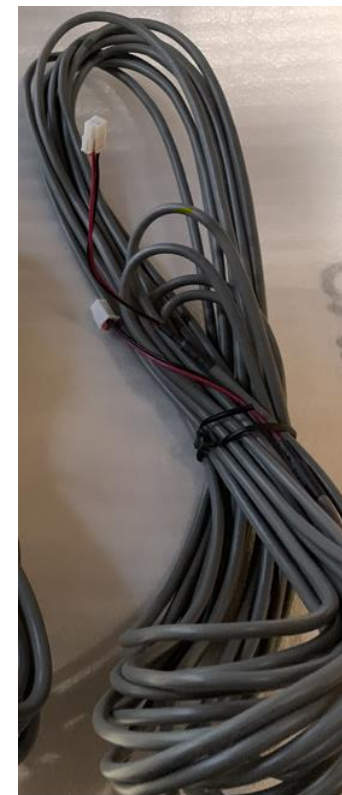

1) Reservekabel voor de bediening:

CN4 (binnenunit)

Indien je de bediening op een andere plaats wil installeren.

Zie blauwe markering op het circuit diagram van de binnenunit



2) Optionele warmtemperatuursensor:

CN16 – RT5 (Binnenunit)

Enkel aan te sluiten als er een supplementaire thermische bron gebruikt wordt (bivalente werking)

Zie de groene markeringen op het circuit diagram van de binnenunit.

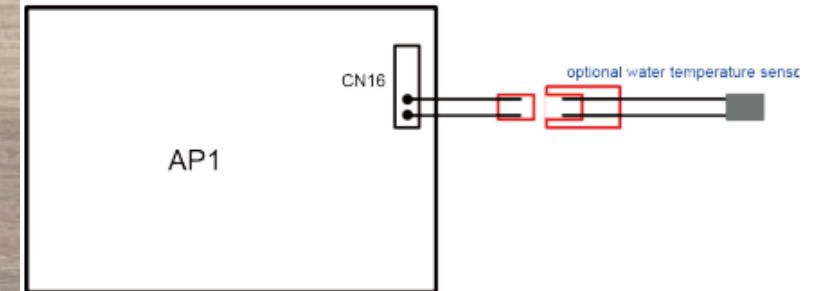

R-AQUA Binnenunit

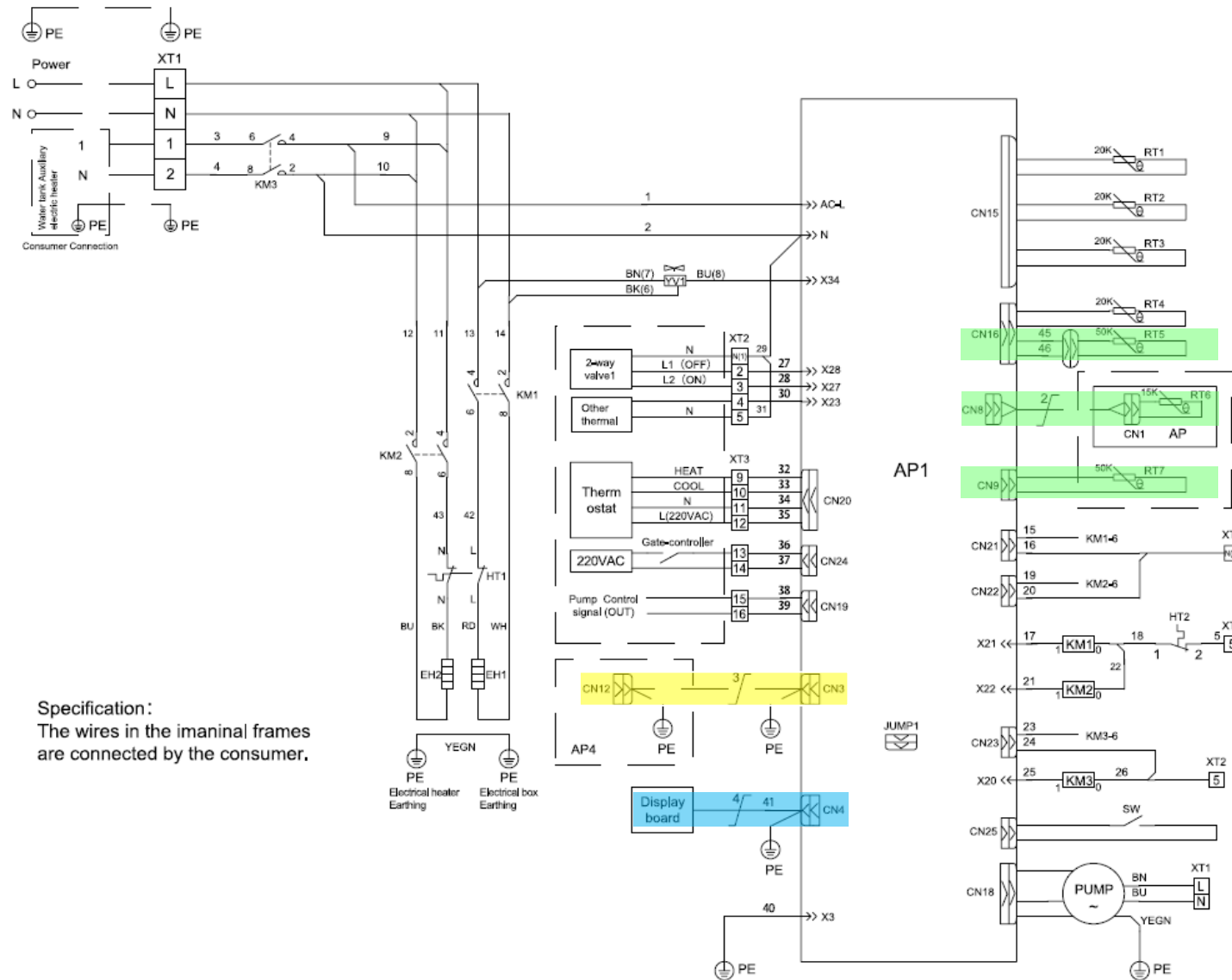

Specification:
The wires in the imanal frames are connected by the consumer.

CODE	NAME
AP	Main board only for RT6
AP1	Indoor unit main board
AP1	Indoor unit main board
AP4	Communication interface board
EH1	Optional electric heater 1
EH2	Optional electric heater 2
HT1	Thermostat 1
HT2	Thermostat 2
KM1	Optional electric heater 1 AC contactor
KM2	Optional electric heater 2 AC contactor
KM3	Water tank electric heater AC contactor
PUMP	Indoor unit pump
RT1	Water-in temp.sensor of the whole unit
RT2	Water-out temp.sensor of the whole unit
RT3	Liquid pipe temp.sensor
RT4	Gas pipe temp.sensor
RT5	Optional water temp.sensor
RT6	Remote room temp.sensor
RT7	Water-tank temp.sensor
SW	Waterflow switch
XT1	Power terminal block
XT2	Terminal block
XT3	Terminal block
YV1	Performer of the electric ball valve

Electric component position map

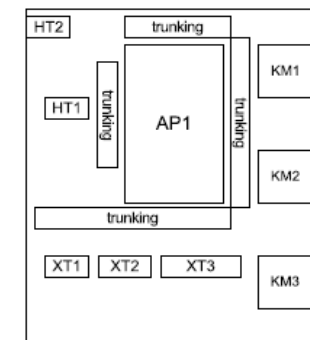

R-AQUA Buitenunit

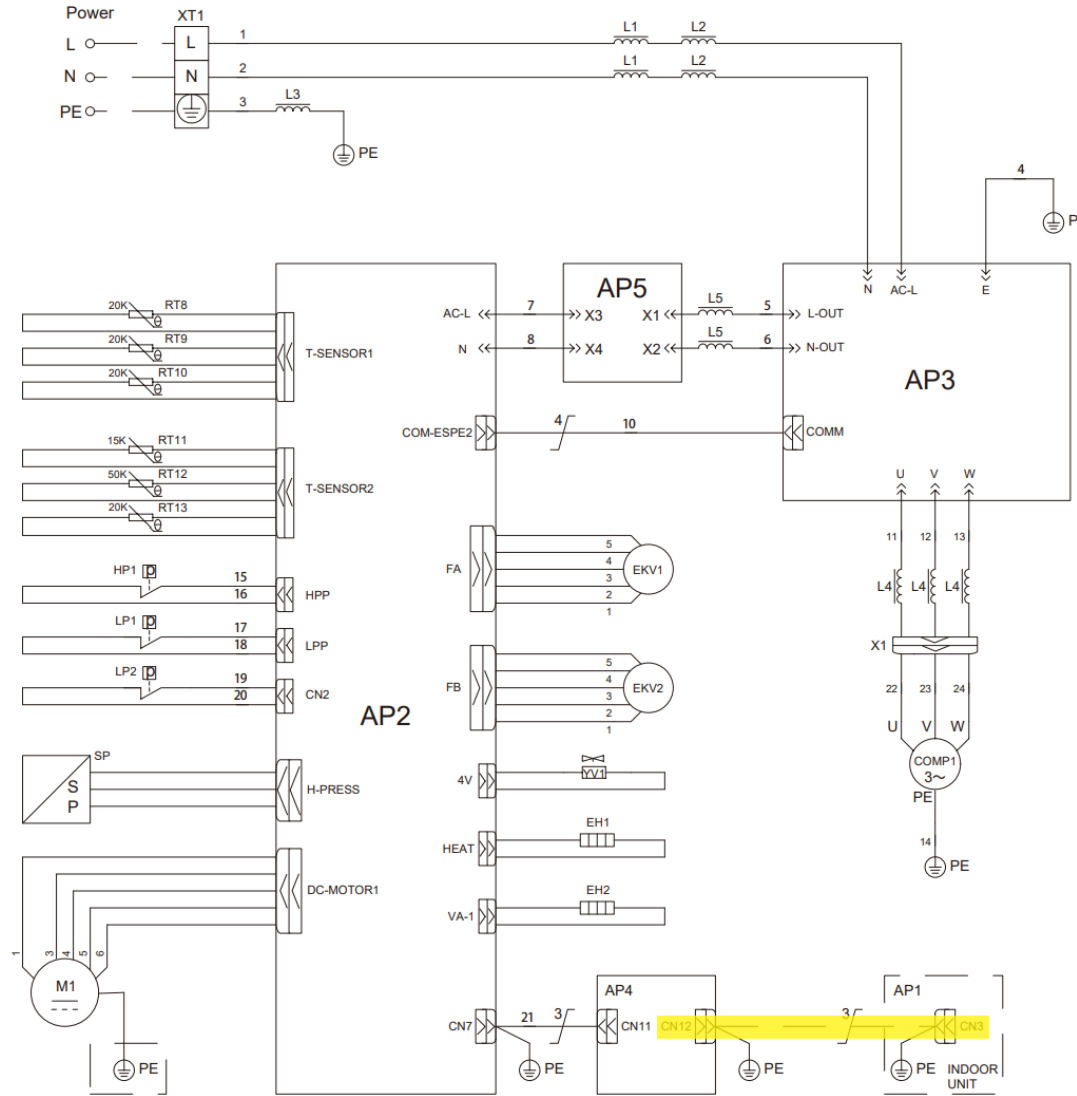

Earthing wire is available for iron-clad motor, while unavailable for plastic-clad motor.

CODE	NAME
AP1	Indoor unit main board
AP2	Outdoor unit main board
AP3	Drive board
AP4	Communication interface Board
AP5	Filter board
COMP1	Compressor
EH1	Compressor band heater
EH2	Bottom band heater
EKV1	Main electronic expansion valve coil
EKV2	Auxiliary electronic expansion valve coil
HP1	High pressure switch
L1-L5	Magnetic ring
LP1	Low pressure switch for heating
LP2	Low pressure switch for cooling
M1	DC motor
RT8	Inlet temp.sensor of economizer
RT9	Outlet temp.sensor of economizer
RT10	Defrosting temp.sensor
RT11	Outdoor temp.sensor
RT12	Discharged temp.sensor
RT13	Suction temp.sensor
SP	High pressure sensor
XT1	Power terminal block
YV1	4-way valve coil

Electric component position map

