

**VWR-N  
(RAL9016)**

- Swirl diffusers
- Square
- Steel
- White, RAL 9016

**CAIROX**

## Square swirl diffusers with fixed blades type VWR-N (RAL9016)

Square swirl ceiling diffusers with fixed blades

### Brand

- Cairox

### Application

- For air supply and exhaust in ventilation and air conditioning systems

### Material

- Steel

### Colour

- Standard colour white, RAL 9016
- Other colours available upon request

### Composition

- Fixed blades

### Mounting

- Fixing with central screw into the crossbar of the plenum box

### Accessories

- Plenum box, type **RER-LB**
- Insulated plenum box, type **RER-LB ISO**
- Regulating valve for plenum box, type **CRC**
- Mounting crossbar for direct duct mounting, type **FGN**
- Mounting crossbar for direct ceiling mounting, type **FHN**

### Text for tender

- The square air supply diffusers are of the swirl type with fixed blades. They are made of steel with white powder coating RAL 9016 and supplied with a volume control damper in the plenum box.
- **Cairox type VWR-N+RER-L**

### Order example

- **VWR-N, 315 + RER-LB 315 + CRC 250**

Explanation

**VWR-N** = Diffuser type

**315** = Diffuser size (Ø diffuser neck connection)

Accessories

**RER-LB** = Plenum box  
**CRC** = Regulating valve for plenum box  
**250** = Plenum box connection diameter

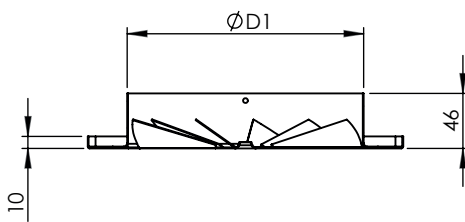
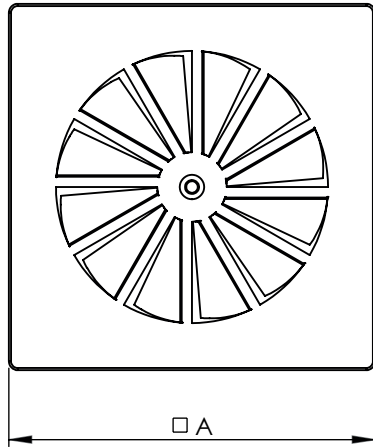

Dimensions			
VWR-N	A [mm]	ØD1 [mm]	#Blades
125	171	123	8
160	213	158	10
200	264	198	12
250	326	248	14
315	404	313	16
355	448	353	17
400	500	398	18
500	596	498	20

		Quick selection																								
VWR-N		125			160			200			250			315			355			400			500			
Q	Ak	0.0099			0.0123			0.0176			0.0226			0.033			0.0359			0.05			0.0618			
	B	1.2	2.4	3.6	1.2	2.4	3.6	1.2	2.4	3.6	1.2	2.4	3.6	1.2	2.4	3.6	1.2	2.4	3.6	1.2	2.4	3.6	1.2	2.4	3.6	
50	Vz	H= 2.7	0.08	0.05	0.04																					
		H= 3.2	0.06	0.04	0.04																					
		H= 3.8	0.04	0.04	0.03																					
	Vk	1.4																								
	X0.25	0.5																								
	Ps	11																								
Lw(A)	<20																									
100	Vz	H= 2.7	0.15	0.11	0.08	0.14	0.1	0.08	0.11	0.08	0.06															
		H= 3.2	0.11	0.09	0.07	0.1	0.08	0.06	0.09	0.07	0.05															
		H= 3.8	0.09	0.07	0.06	0.08	0.06	0.05	0.07	0.05	0.05															
	Vk	2.8			2.3			1.6																		
	X0.25	0.9			0.8			0.7																		
	Ps	45			19			6																		
Lw(A)	35			26			<20																			
150	Vz	H= 2.7	0.23	0.16	0.13	0.21	0.15	0.11	0.17	0.12	0.1	0.15	0.11	0.08												
		H= 3.2	0.17	0.13	0.11	0.15	0.12	0.1	0.13	0.1	0.08	0.11	0.09	0.07												
		H= 3.8	0.13	0.11	0.09	0.12	0.1	0.08	0.1	0.08	0.07															
	Vk	4.2			3.4			2.4			1.8															
	X0.25	1.4			1.2			1			0.9															
	Ps	100			41			14			5															
Lw(A)	46			38			24			<20																
200	Vz	H= 2.7	0.31	0.22	0.17	0.27	0.2	0.15	0.23	0.16	0.13	0.2	0.14	0.11	0.17	0.12	0.09	0.18	0.13	0.1						
		H= 3.2	0.23	0.18	0.14	0.21	0.16	0.13	0.17	0.13	0.11	0.15	0.12	0.09	0.13	0.1	0.08	0.13	0.1	0.08						
		H= 3.8	0.18	0.14	0.12	0.16	0.13	0.11	0.13	0.11	0.09	0.12	0.09	0.08	0.1	0.08	0.07	0.1	0.08	0.07						
	Vk	5.6			4.5			3.2			2.5			1.7			1.5									
	X0.25	1.8			1.6			1.4			1.2			1			1.1									
	Ps	178			72			25			9			3			2									
Lw(A)	54			46			32			22			<20			<20										
300	Vz	H= 2.7						0.34	0.25	0.19	0.3	0.22	0.17	0.25	0.18	0.14	0.27	0.19	0.15	0.23	0.16	0.13				
		H= 3.2						0.26	0.2	0.16	0.23	0.17	0.14	0.19	0.14	0.12	0.2	0.16	0.13	0.17	0.13	0.11	0.13	0.16	0.13	
		H= 3.8						0.2	0.16	0.14	0.17	0.14	0.12	0.14	0.12	0.1	0.16	0.13	0.11	0.13	0.11	0.09				
	Vk							4.7			3.7			2.5			2.3			1.7						
	X0.25							2.1			1.8			1.5			1.6			1.4						
	Ps							54			20			6			4			2						
Lw(A)							43			33			<20			<20			<20							
400	Vz	H= 2.7									0.4	0.29	0.22	0.33	0.24	0.19	0.36	0.26	0.2	0.3	0.22	0.17	0.24	0.17	0.13	
		H= 3.2									0.3	0.23	0.19	0.25	0.19	0.16	0.27	0.21	0.17	0.23	0.18	0.14	0.18	0.14	0.11	
		H= 3.8									0.23	0.19	0.16	0.19	0.16	0.13	0.21	0.17	0.14	0.18	0.14	0.12	0.14	0.11	0.09	
	Vk							4.9			3.4			3.1			2.2			1.8						
	X0.25							2.4			2			2.2			1.8			1.4						
	Ps							35			12			8			4			3						
Lw(A)							41			27			23			<20			<20							
500	Vz	H= 2.7												0.42	0.3	0.23	0.45	0.32	0.25	0.38	0.27	0.21	0.29	0.21	0.16	
		H= 3.2												0.31	0.24	0.2	0.34	0.26	0.21	0.29	0.22	0.18	0.22	0.17	0.14	
		H= 3.8												0.24	0.2	0.16	0.26	0.21	0.18	0.22	0.18	0.15	0.17	0.14	0.12	
	Vk							4.2			3.9			2.8			2.2			1.8						
	X0.25							2.5			2.7			2.3			1.8			1.4						
	Ps							18			13			7			4			3						
Lw(A)							33			30			<20			<20			<20							
600	Vz	H= 2.7												0.5	0.36	0.28	0.54	0.39	0.3	0.46	0.33	0.25	0.35	0.25	0.2	
		H= 3.2												0.38	0.29	0.24	0.4	0.31	0.25	0.34	0.26	0.21	0.27	0.2	0.17	
		H= 3.8												0.29	0.24	0.2	0.31	0.25	0.21	0.26	0.21	0.18	0.2	0.17	0.14	
	Vk							5.1			4.6			3.3			2.7			2.1						
	X0.25							3			3.2			2.7			2.1			1.6						
	Ps							26			18			9			6			4						
Lw(A)							38			35			22			<20			<20							
800	Vz	H= 2.7																		0.61	0.44	0.34	0.47	0.34	0.26	
		H= 3.2																		0.46	0.35	0.29	0.35	0.27	0.22	
		H= 3.8																		0.35	0.29	0.24	0.27	0.22	0.19	
	Vk							4.4			3.6			2.8			2.2			1.8						
	X0.25							3.7			2.8			2.3			1.8			1.4						
	Ps							16			11			7			4			3						
Lw(A)							30			22			<20			<20			<20							
1000	Vz	H= 2.7																		0.76	0.54	0.42	0.59	0.42	0.33	
		H= 3.2																		0.57	0.44	0.36	0.44	0.34	0.28	
		H= 3.8																		0.44	0.36	0.3	0.34	0.28	0.23	
	Vk							5.6			4.5			3.5			2.8			2.2						
	X0.25							4.6			3.5			2.7			2.1			1.6						
	Ps							26			17			11			7			4						
Lw(A)							36			28			<20			<20			<20							
1200	Vz	H= 2.7																				0.71	0.51	0.39		
		H= 3.2																				0.53	0.41	0.33		
		H= 3.8																				0.41	0.33	0.28		
	Vk							5.4			4.2			3.2			2.4			1.8						
	X0.25							4.2			3.2			2.4			1.8			1.4						
	Ps							24			17			11			7			4						
Lw(A)							33			28			<20			<20			<20							

**Symbols and specifications**

- Q = Air volume in m<sup>3</sup>/h
- Ak = Effective surface (free area) in m<sup>2</sup>
- B = Distance between the diffusers in m
- H = Installation height of the diffusers in m
- Vz = Maximum velocity at the occupied zone according to distance between the diffusers and installation height in m/s
- Vk = Average effective velocity through the diffuser in m/s
- X0.25 = Throw length in m at an end velocity Vt of 0,25m/s
- Ps = Static pressure loss given in Pa
- Lw(A) = Acoustic power in dB(A)

- The throw X0.25 is given at an end velocity of 0.25m/s for a smooth ceiling without any obstacles.
- The values are given for isothermal supply air. Throw distances for cooling conditions at -11K can be calculated by dividing the X0.25 values with factor 1.1. For heating purposes at Dt of +11K a multiplier of 1.1 should be applied to the

given  $X_{0.25}$  value.

- In order to achieve a high comfort level, selections can be made according to the maximal velocity at the occupied zone  $V_z$ . These values are given at distances between diffusers  $B$  and installation heights  $H$ . Velocities  $V_z$  lower than, or equal to  $0,25\text{m/s}$  at the occupied zone are advised.
- The pressure losses  $P_s$  are given for diffusers without damper or with fully opened damper.
- The acoustic power values  $L_w(A)$  are given for diffusers without damper or with fully opened damper without room attenuation. Acoustic powers below  $20\text{dB}(A)$  are mentioned as " $<20$ " in the tables.
- For all special requirements, please contact our engineering office.

### Placement instruction

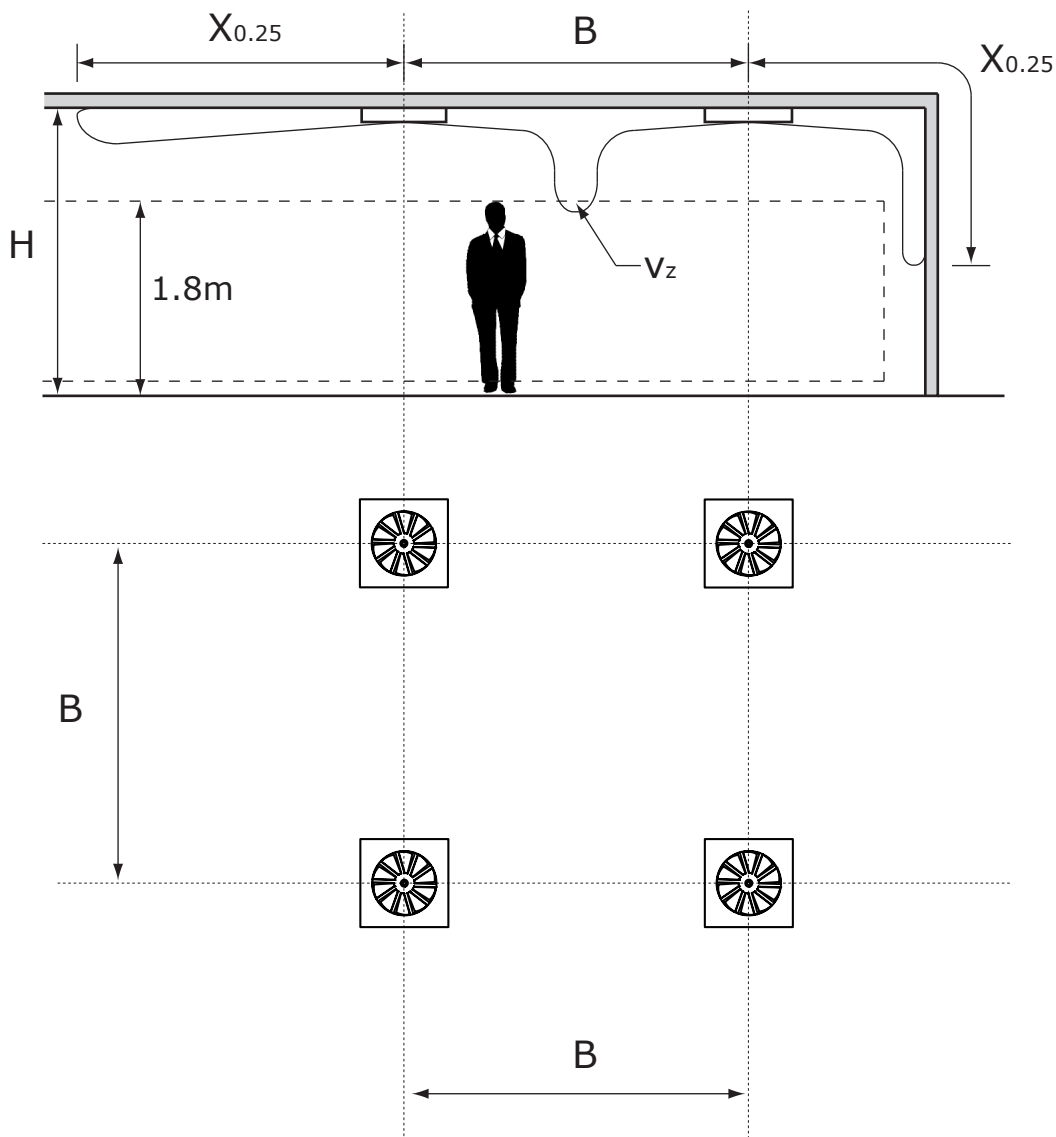

- Plenum boxes
- Circular
- Steel



## Circular plenum boxes type RER-LB

Circular galvanized steel plenum box **RER-LB** with crossbar. To be combined with (PS)/RWR-N, VWR-N, RWR-2 and PRN

### Brand

- Cairox

### Application

- Connection of circular ductwork and circular diffusers
- Velocity reduction towards diffusers
- Diffuser mounting in plasterboard or false system ceilings

### Material

- Galvanized steel

### Composition

- Circular plenum box made out of galvanized steel
- Circular side entry spigot
- Mounted crossbar with M6 screw connection in the middle
- Rubber seal between plenum box and diffuser to make an airtight connection

### Accessories

- Circular regulating valve, type **CRC**

### Order example

- **RER-LB, 200 + CRC 160**

Explanation

**RER-LB** = Plenum box type

**200** = Size according to diffuser (Ø diffuser neck connection)

Accessory

**CRC 160** = Volume control damper for plenumbox connection Ø160

### Other available products

- Insulated plenum box type **RER-LB ISO**

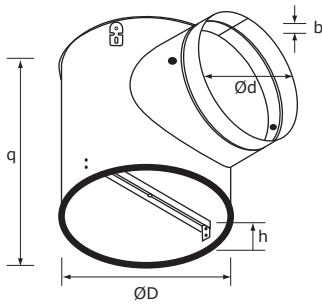

Dimensions					
RER-LB	ØD [mm]	q [mm]	Ød [mm]	b [mm]	h [mm]
100	111	148	80	15	65
125	136	168	100	15	65
160	171	193	125	15	65
200	211	228	160	15	65
250	261	268	200	15	65
315	326	318	250	15	65
355	366	318	250	15	65
400	411	383	315	15	65
500	511	383	315	15	65