

**CNC-1A
(RAL9016)**

- Multinozzle diffusers
- Circular
- Steel and plastics
- White, RAL 9016

CAIROX

Circular nozzle diffusers with circular pattern type CNC-1A (RAL9016)

Multinozzle ceiling diffusers with high induction rate, consisting of a circular plate with individual adjustable nozzles arranged in a circular pattern to be equipped with galvanized steel plenum box.

Brand

- Cairox

Application

- For air supply and exhaust in ventilation and air conditioning systems.

Material

- Steel and plastic composite combination

Colour

- Standard colour white, RAL 9016
- Nozzles and diffuser available in RAL 9016 / 9010 / 9006 / 9005

Composition

- Frontplate made of powder coated steel
- Nozzles made out of plastic composite
- Central screw mounting

Mounting

- Fixing by central screw in the crossbar of the plenum box.

Accessories

- Circular plenum box **RER-B**
- Circular insulated plenum box **RER-B ISO**
- Regulating valve for plenum box type **CRC**

Text for tender

- The air supply ceiling diffusers are circular with a circular arranged nozzle pattern. They are made of a steel powdercoated frontplate in white finish RAL 9016 and nozzles in plastic composite materials. The diffusers are standard delivered with galvanized steel plenumbox equipped with perforated plate and damper in the side entry spigot. The diffuser is centrally screw mounted.
- **Cairox** type **CNC-1A + RER-A**

Order example■ **CNC-1A, 600 + RER-B 600 + CRC 250**

Explanation

CNC-1A = Diffuser type**600** = Diffuser size

Accessories

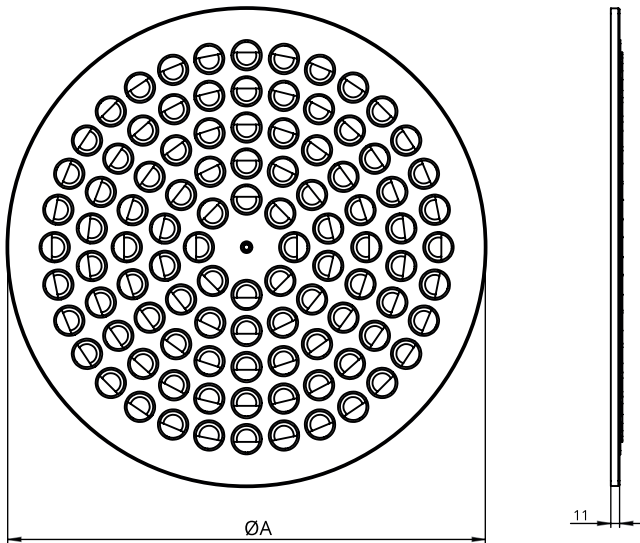
RER-B = Plenum box**600** = Size plenum box**CRC** = Regulating valve for plenum box**250** = Plenum box connection diameter 250

CNC-1A	Dimensions	
	ØA [mm]	# Nozzles
300	300	22
400	400	42
500	500	68
600	600	100
625*	625	100

* niet meer verkrijgbaar / n'est plus disponible / no longer available

CNC 1A - #Nozzles		Quick selection												
		300 - #22			400 - #42			500 - #68			600 - #100 / 625* - #100			
Q	Ak	0.0057			0.0114			0.0153			0.0258			
	B	1.2	2.4	3.6	1.2	2.4	3.6	1.2	2.4	3.6	1.2	2.4	3.6	
50	Vz	H= 2.7	0.3	0.12	0.06	0.25	0.1	0.05						
		H= 3.2	0.14	0.07	0.04	0.12	0.06	0.03						
		H= 3.8	0.07	0.04	0.02	0.06	0.03	0.02						
	Vk		2.4			1.2								
	X0,25		1.6			1.5								
	Ps		6			2								
	Lw(A)	24			<20									
75	Vz	H= 2.7	0.42	0.19	0.11	0.34	0.15	0.08	0.32	0.14	0.08			
		H= 3.2	0.22	0.12	0.07	0.17	0.09	0.06	0.16	0.08	0.05			
		H= 3.8	0.12	0.07	0.05	0.09	0.06	0.04	0.08	0.05	0.03			
	Vk		3.7			1.8			1.4					
	X0,25		1.8			1.7			1.6					
	Ps		13			4			2					
	Lw(A)	33			<20			<20						
100	Vz	H= 2.7	0.53	0.27	0.16	0.42	0.2	0.12	0.38	0.18	0.1	0.3	0.13	0.07
		H= 3.2	0.29	0.17	0.11	0.22	0.13	0.08	0.2	0.11	0.07	0.15	0.08	0.05
		H= 3.8	0.17	0.11	0.08	0.13	0.08	0.05	0.11	0.07	0.05	0.08	0.05	0.03
	Vk		4.9			2.4			1.8			1.1		
	X0,25		2.1			1.9			1.8			1.6		
	Ps		24			7			4			2		
	Lw(A)	38			23			<20			<20			
150	Vz	H= 2.7				0.58	0.3	0.19	0.51	0.26	0.16	0.39	0.18	0.11
		H= 3.2				0.33	0.2	0.14	0.29	0.17	0.11	0.21	0.12	0.07
		H= 3.8				0.2	0.14	0.1	0.17	0.11	0.08	0.12	0.07	0.05
	Vk					3.7			2.7			1.6		
	X0,25					2.3			2.1			1.8		
	Ps					16			9			3		
	Lw(A)				33			27			<20			
200	Vz	H= 2.7				0.71	0.4	0.26	0.63	0.34	0.22	0.49	0.25	0.15
		H= 3.2				0.43	0.28	0.19	0.37	0.23	0.16	0.27	0.16	0.11
		H= 3.8				0.28	0.19	0.14	0.23	0.16	0.12	0.16	0.11	0.08
	Vk					4.9			3.6			2.2		
	X0,25					2.7			2.4			2		
	Ps					28			16			6		
	Lw(A)				40			34			23			
250	Vz	H= 2.7							0.74	0.42	0.28	0.57	0.3	0.19
		H= 3.2							0.46	0.3	0.21	0.33	0.2	0.14
		H= 3.8							0.3	0.21	0.16	0.2	0.14	0.1
	Vk								4.5			2.7		
	X0,25								2.8			2.3		
	Ps								25			9		
	Lw(A)							40			28			
300	Vz	H= 2.7							0.85	0.5	0.34	0.64	0.35	0.23
		H= 3.2							0.54	0.36	0.26	0.39	0.24	0.17
		H= 3.8							0.36	0.26	0.2	0.24	0.17	0.12
	Vk								5.4			3.2		
	X0,25								3.2			2.5		
	Ps								35			13		
	Lw(A)							45			33			
350	Vz	H= 2.7										0.73	0.42	0.27
		H= 3.2										0.45	0.29	0.21
		H= 3.8										0.29	0.21	0.16
	Vk											3.8		
	X0,25											2.8		
	Ps											18		
	Lw(A)										37			
400	Vz	H= 2.7										0.79	0.47	0.31
		H= 3.2										0.51	0.33	0.24
		H= 3.8										0.33	0.24	0.18
	Vk											4.3		
	X0,25											3		
	Ps											23		
	Lw(A)										41			
450	Vz	H= 2.7										0.86	0.52	0.36
		H= 3.2										0.56	0.38	0.28
		H= 3.8										0.38	0.28	0.21
	Vk											4.8		
	X0,25											3.3		
	Ps											29		
	Lw(A)										44			

Symbols and specifications

- Q = Air volume in m³/h
 - Ak = Effective surface (free area) in m²
 - B = Distance between the diffusers in m
 - H = Installation height of the diffusers in m
 - Vz = Maximum velocity at the occupied zone according to distance between the diffusers and installation height in m/s
 - Vk = Average effective velocity through the diffuser in m/s
 - X0.25 = Throw length in m at an end velocity Vt of 0,25m/s
 - Ps = Static pressure loss given in Pa
 - Lw(A) = Acoustic power in dB(A)
- The throw X0.25 is given at an end velocity of 0.25m/s for a smooth ceiling without any obstacles.
 - The values are given for isothermal supply air. Throw distances for cooling conditions at -11K can be calculated by dividing the X0.25 values with factor 1.1. For heating purposes at Dt of +11K a multiplier of 1.1 should be applied to the given X0.25 value.
 - In order to achieve a high comfort level, selections can be made according to the maximal velocity at the occupied zone Vz. These values are given at distances between diffusers B and installation heights H. Velocities Vz lower than, or equal to 0,25m/s at the occupied zone are advised.
 - The pressure losses Ps are given for diffusers without damper or with fully opened damper.

- The acoustic power values $L_w(A)$ are given for diffusers without damper or with fully opened damper without room attenuation. Acoustic powers below 20dB(A) are mentioned as "<20" in the tables.
- For all special requirements, please contact our engineering office.

- Plenum boxes
- Circular
- Steel

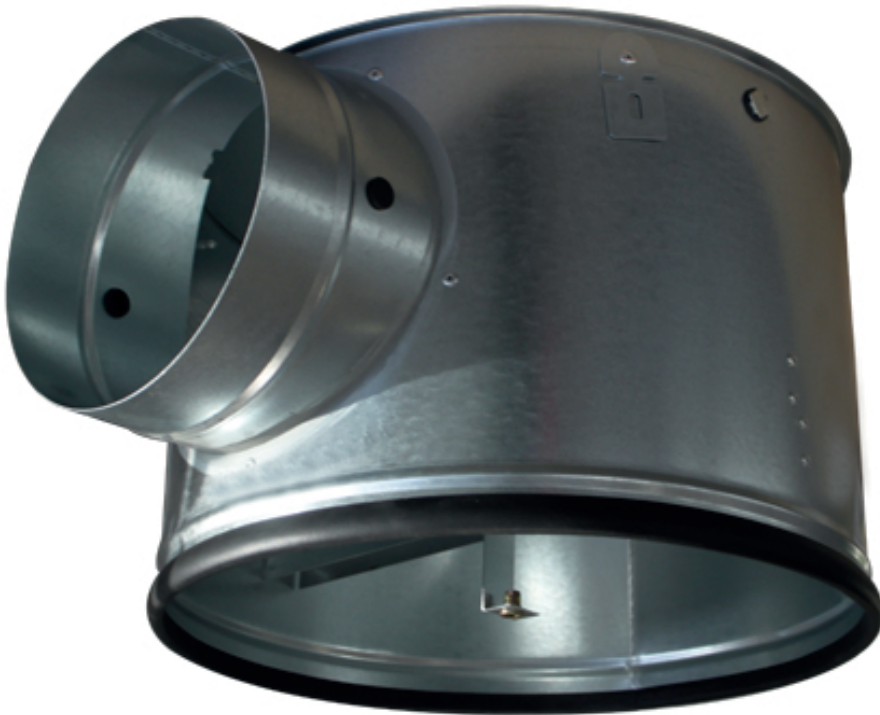

Circular plenum box type RER-B

Universal circular plenum boxes with perforated plate in galvanized steel

Brand

- Cairox

Composition

- Circular body in plain steel plate
- Crossbar for central mounting with M6 screw of diffuser
- Perforated equalizing plate for equal air diffusion inside the box
- Circular connection spigot
- Seal for airtight connection with the diffuser

Accessories

- Circular valve control damper , type **CRC**

Order example

- **RER-B 600 + CRC 250**

Explanation

RER-B = Plenum box type

600 = Size type

Accessory

CRC 250 = Regulating valve for plenum box connection Ø250

Other available products

- Insulated plenumboxes type **RER-B ISO**

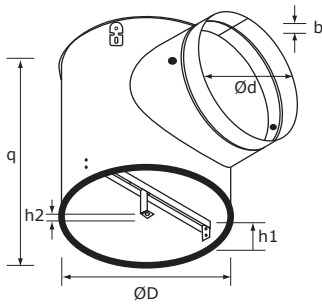

RER-B	Dimensions					
	ØD [mm]	q [mm]	Ød [mm]	b [mm]	h1 [mm]	h2 [mm]
300	275	230	160	15	65	10
400	375	270	200	15	65	10
500	476	270	200	15	65	10
600	576	320	250	15	65	10