



Rectangular VAV dampers type VAV-RSB BELIMO

VAV-RSB air flow regulator can be used both for variable and constant flow and, if appropriate, for forced shut-off for both air supply and air exhaust.

Application

- Regulating of air volumes to change the temperature or air quality in a room
- Control and regulate the supply air flow and exhaust air flow
- Airflow range can be set between two set values or as constant airflow

Material

- Galvanized steel

Composition

- Operating range is between 2 to 12 m/s
- Integrated flow measurement with separate measurement nipples for control and manual measurement
- The damper has stable synthetic bearings and its shaft is mounted in maintenance free synthetic bearings
- Airtightness of the casing class C in accordance with EN1751
- Blade airtightness class 3 in accordance with EN1751 in closed position

Controls

- Controller type Belimo LMV-D3-MP (5Nm) and Belimo NMV-D3-MP (10Nm) are pressure regulated actuators for pressure independent controls. Settings can be done by using the Assistant App* (smartphone) with NFC connection (Near Field Communication) or by using the service tool ZTH (PC-tool).
- Operating range 0-10V or 2-10V (Standard set on 0-10V)
- Units of airflow: l/s or m³/h
- Minimum adjustable air volume set at air velocity at +/- 2 m/s and maximum adjustable airvolume set at air velocity of 12 m/s
- Differential pressure range Δp @ V_{nom} 38 - 500 Pa
- Running time over the full actuator range : 100s
- Power consumption 5 Nm: 2W, 3.5VA / 10 Nm: 3W , 5VA
- Supply voltage 24V AC/DC

* Assistant App available in App Store & Google Play Store

* For iPhone an ZIP-BT-NFC converter is needed!

Options

- Insulated version **VAV-RSB-I**, standard insulation thickness 30mm
- Other communication types (ModBus, KNX) and other brands of servomotors available on request
- Airtightness class C available upon request

Accessories

- Sound attenuator, type **BTH-B**

Order example

- **VAV-RSB 400 X 100 LXH**

Explanation:

VAV-RSB = Airflow regulator type

400 X 100 LXH = Dimension of the damper

Selection table			
Type VAV	Qmin [m ³ /h]	Qmax [m ³ /h]	Vnom / Qnom [m ³ /h]
VAV-RSB 200x100LxH	130	720	720
VAV-RSB 200 x 200 LxH	255	1440	1440
VAV-RSB 300x100 LxH	190	1080	1080
VAV-RSB 300x200 LxH	380	2160	2160
VAV-RSB 300x300 LxH	570	3240	3240
VAV-RSB 400x100 LxH	255	1440	1440
VAV-RSB 400x200 LxH	505	2880	2880
VAV-RSB 400x300 LxH	755	4320	4320
VAV-RSB 400x400 LxH	1005	5760	5760
VAV-RSB 500x200 LxH	630	3600	3600
VAV-RSB 500x300 LxH	940	5400	5400
VAV-RSB 500x400 LxH	1255	7200	7200
VAV-RSB 500x500 LxH	1570	9000	9000
VAV-RSB 600x200 LxH	755	4320	4320
VAV-RSB 600x300 LxH	1130	6480	6480
VAV-RSB 600x400LxH	1505	8640	8640
VAV-RSB 600x500 LxH	755	10800	10800
VAV-RSB 600x600 LxH	2260	12960	12960
VAV-RSB 700x300 LxH	1320	7560	7560
VAV-RSB 700x400 LxH	1755	10080	10080
VAV-RSB 700x500 LxH	2195	12600	12600
VAV-RSB 700x600 LxH	2635	15120	15120
VAV-RSB 700x700 LxH	3070	17640	17640
VAV-RSB 800x300 LxH	1505	8640	8640
VAV-RSB 800x400 LxH	2005	11520	11520
VAV-RSB 800x500 LxH	2510	14400	14400
VAV-RSB 800x600 LxH	3010	17280	17280
VAV-RSB 800x700 LxH	3510	20160	20160
VAV-RSB 900x300 LxH	1695	9720	9720
VAV-RSB 900x400 LxH	2260	12960	12960
VAV-RSB 900x500 LxH	2820	16200	16200
VAV-RSB 900x600 LxH	3385	19440	19440
VAV-RSB 900x700 LxH	3950	22680	22680
VAV-RSB 1000x300 LxH	1880	10800	10800
VAV-RSB 1000x400 LxH	2510	14400	14400
VAV-RSB 1000x500 LxH	3135	18000	18000
VAV-RSB 1000x600 LxH	3760	21600	21600
VAV-RSB 1000x700 LxH	4385	25200	25200

VAV-RSB		Sound data																					
		L	100				200				300				400				500				
			H	3	6	9	12	3	6	9	12	3	6	9	12	3	6	9	12	3	6	9	12
ps = 125 Pa	Lw [dB/Okt]	f [Hz]	Vk [m/s]	3	6	9	12	3	6	9	12	3	6	9	12	3	6	9	12	3	6	9	12
			63	45	55	63	68	51	60	68	73	53	63	71	76	56	65	73	78	59	68	76	81
			125	46	56	63	68	49	58	66	71	51	60	68	73	52	61	69	74	53	63	71	75
			250	42	49	54	57	46	53	58	61	48	55	60	63	50	56	62	64	52	59	64	67
			500	44	47	50	52	45	48	51	53	45	49	51	53	46	49	52	53	46	50	52	54
			1000	46	49	51	53	48	50	53	54	48	51	53	55	49	52	54	55	50	52	55	56
			2000	46	49	51	53	49	52	54	56	51	54	56	58	52	55	57	59	54	57	59	60
			4000	39	43	47	49	41	46	50	52	43	47	51	53	44	49	52	55	45	50	54	56
8000	32	37	41	43	36	41	45	47	38	43	47	50	40	45	49	51	42	47	51	54			
ps = 250 Pa	Lw [dB/Okt]	f [Hz]	63	52	61	68	72	56	64	71	75	58	66	73	77	59	68	75	79	61	70	77	81
			125	49	58	65	70	53	61	69	73	55	64	71	75	56	65	72	77	58	67	74	79
			250	46	53	58	62	49	56	62	66	51	58	64	68	53	60	66	69	55	62	68	72
			500	48	52	56	58	50	54	58	60	51	55	59	61	51	56	59	62	52	57	61	63
			1000	51	54	57	59	52	56	59	61	53	57	60	61	54	57	60	62	55	58	61	63
			2000	53	56	58	59	56	58	61	62	57	60	62	64	58	61	63	65	60	63	65	66
			4000	49	52	55	57	51	54	57	59	52	56	59	60	53	56	59	61	54	58	61	63
			8000	45	49	52	54	47	51	54	56	49	53	56	58	50	54	57	59	51	55	58	60
ps = 500 Pa	Lw [dB/Okt]	f [Hz]	63	57	65	72	76	60	69	76	80	63	71	78	82	64	73	80	84	67	75	82	86
			125	53	63	71	77	56	66	74	80	58	68	76	81	59	69	77	83	61	71	79	84
			250	49	58	66	70	55	64	72	76	59	68	75	80	61	70	78	82	64	74	81	86
			500	53	59	63	66	56	62	66	69	58	63	68	71	59	65	69	72	61	66	71	73
			1000	59	62	64	66	61	64	66	67	62	64	67	68	62	65	68	69	63	66	69	70
			2000	64	65	66	66	66	67	68	69	68	69	70	70	69	70	71	71	70	71	72	73
			4000	63	64	65	66	65	66	67	68	66	67	68	69	67	68	69	69	68	69	70	70
			8000	59	61	63	64	61	63	65	66	62	65	66	68	63	65	67	69	64	67	69	70

		Correction factor for other widths																							
		Δps = 125 Pa								Δps = 250 Pa								Δps = 500 Pa							
L [mm]	H [mm]	63	125	250	500	1000	2000	4000	8000	63	125	250	500	1000	2000	4000	8000	63	125	250	500	1000	2000	4000	8000
		L = 600 mm	200	-8	-4	-6	-2	-2	-5	-4	-6	-5	-6	-6	-3	-3	-4	-3	-4	-6	-5	-10	-5	-3	-4
300	-5		-3	-4	-1	-1	-3	-3	-4	-3	-4	-4	-2	-2	-3	-2	-3	-4	-3	-6	-3	-2	-3	-2	-2
400	-3		-2	-2	-1	-1	-2	-2	-2	-2	-2	-2	-1	-1	-2	-1	-1	-1	-2	-4	-2	-1	-2	-1	-1
500	-1		-1	-1	0	0	-1	-1	-1	-1	-1	-1	0	0	-1	-1	-1	-1	-1	-2	-1	0	-1	0	-1
600	0		0	0	0	0	0	0	0	0	0	0	0	0	0	0	0	0	0	0	0	0	0	0	0
700	1		1	1	0	0	1	1	1	1	1	1	0	0	1	0	1	1	1	1	1	1	1	0	0
800	2		1	2	0	1	1	1	2	1	1	2	1	1	1	1	1	2	1	3	1	1	1	1	1
L = 1000 mm	900	3	2	2	1	1	2	2	2	2	2	2	1	1	2	1	1	2	2	4	2	1	2	1	1
	1000	4	2	3	1	1	2	2	3	3	3	1	1	2	2	2	3	2	4	2	1	2	1	2	2
	800	-2	-1	0	-1	-1	-1	-1	0	-1	-1	-1	-1	-1	-1	-1	-1	-1	-1	-1	-2	-1	-1	-1	-1
L = 1000 mm	900	-1	-1	0	-1	0	0	-1	-1	-1	-1	-1	0	0	0	0	0	-1	-1	0	-1	0	0	0	0
	1000	0	0	0	0	0	0	0	0	0	0	0	0	0	0	0	0	0	0	0	0	0	0	0	0

- VAV-RSB = Variable or constant volume damper
- Q = In-Duct air volume in m³/h
- Qmin - Qmax = minimum and maximum set point in m³/h
- Vk = Average velocity in the damper in m/s
- Ps = Pressure drop over the damper according to the position of the blade
- Lw [dB/Okt] = Sound power given at a specific pressure drop Ps for the frequencies f[Hz] from 63 up to 8000 Hz in dB
- Correction factor for other widths in relation to the sizes L=600mm and L=1000mm in dB

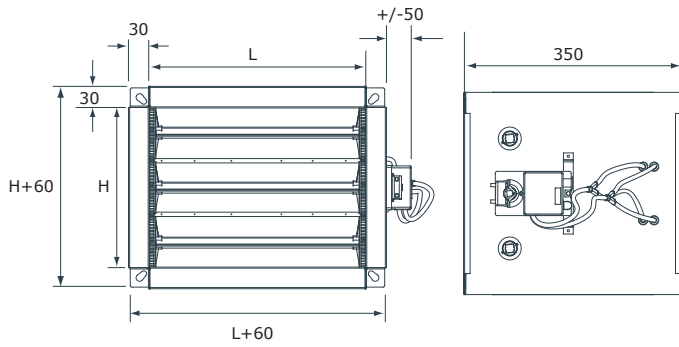

VAV-RSB	Dimensions		
	L [mm]	H [mm]	kg
200 x 100	200	100	2.8
200 x 200	200	200	3.7
300 x 100	300	100	3.3
300 x 200	300	200	4.5
300 x 300	300	300	5.8
400 x 100	400	100	3.7
400 x 200	400	200	5.4
400 x 300	400	300	7.1
400 x 400	400	400	8.8
500 x 200	500	200	6.2
500 x 300	500	300	8.3
500 x 400	500	400	10.4
500 x 500	500	500	12.6
600 x 200	600	200	7.1
600 x 300	600	300	9.6
600 x 400	600	400	12.1
600 x 500	600	500	14.7
600 x 600	600	600	17.2
700 x 300	700	300	10.9
700 x 400	700	400	13.8
700 x 500	700	500	16.8
700 x 600	700	600	19.7
700 x 700	700	700	22.7
800 x 300	800	300	12.1
800 x 400	800	400	15.5
800 x 500	800	500	18.9
800 x 600	800	600	22.3
800 x 700	800	700	25.7
900 x 300	900	300	13.4
900 x 400	900	400	17.2
900 x 500	900	500	21
900 x 600	900	600	24.8
900 x 700	900	700	28.6
1000 x 300	1000	300	14.7
1000 x 400	1000	400	18.9
1000 x 500	1000	500	23.1
1000 x 600	1000	600	27.3
1000 x 700	1000	700	31.6

Mounting

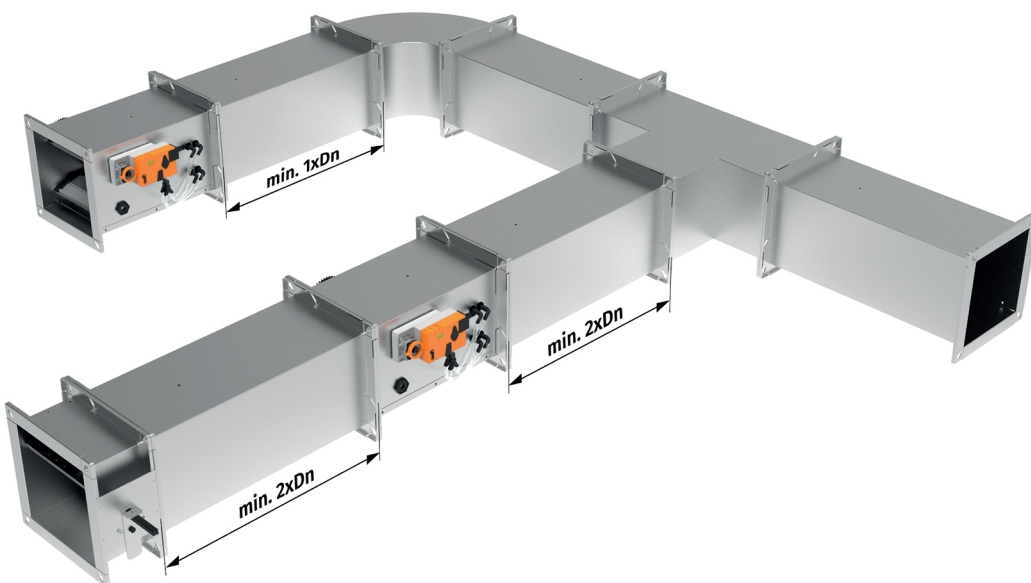

Controle modes

