



Fan boxes - 25 mm insulation and safety switch type CVI-DP

Insulated direct driven centrifugal fan box

Application

- Air supply or exhaust of offices, restaurants or shops
- Convenient for indoor and outdoor installation

Composition

- The casing of the **CVI-DP** is made of double-walled galvanized steel sheets with 25 mm insulation (fire class A1 according to EN 13501-1)
- Two removable side panels allow quick and easy maintenance
- Round connections on suction and discharge side
- Equipped with a work switch
- A connection box for electrical connection is provided

Fan

- Low pressure centrifugal fan with forward curved impeller manufactured from pressed and formed galvanised sheet steel
- All impellers are factory fitted to the motors and dynamically balanced to minimise vibration

Motor

- Protection class IP55 of IP 44, insulation class F
- Supply: 230Vac 1ph or 230/400Vac 3ph
- All models include a Safety Thermal Overload protection device

Accessories

- Auto transformer 230V, type **TSC-1**
- Auto transformer 3x400V, type **TSCTK-4**
- Frequency converter 230V in / 3x230V out, type **FIS(-C)-13-B**
- Frequency converter 3x400V in / 3x400V out, type **FIS(-C)-44-B**
- Clamping strip, type **BMK**

Air performance data															
	Q [m³/h]														
	50 Pa	100 Pa	150 Pa	200 Pa	250 Pa	300 Pa	350 Pa	400 Pa	450 Pa	500 Pa	550 Pa	600 Pa	650 Pa	700 Pa	750 Pa
CVI-DP 7/7-4A M	-	1700	1650	1450	750	-	-	-	-	-	-	-	-	-	-
CVI-DP 9/9-6 M	2800	2600	2100	-	-	-	-	-	-	-	-	-	-	-	-
CVI-DP 9/9-4 M	-	-	3530	3375	3150	2800	2525	700	-	-	-	-	-	-	-
CVI-DP 10/10-6 M	-	3350	3175	2750	350	-	-	-	-	-	-	-	-	-	-
CVI-DP 12/9-6 M	-	-	-	4680	4150	3500	860	-	-	-	-	-	-	-	-
CVI-DP 12/12-6 M	-	-	-	-	4850	2000	685	-	-	-	-	-	-	-	-
CVI-DP 12/12-6 T	-	-	-	6550	5750	4680	1450	935	-	-	-	-	-	-	-
CVI-DP 15/15-6 T	-	-	-	-	-	-	9000	6625	5000	1310	435	-	-	-	-

Selection curves

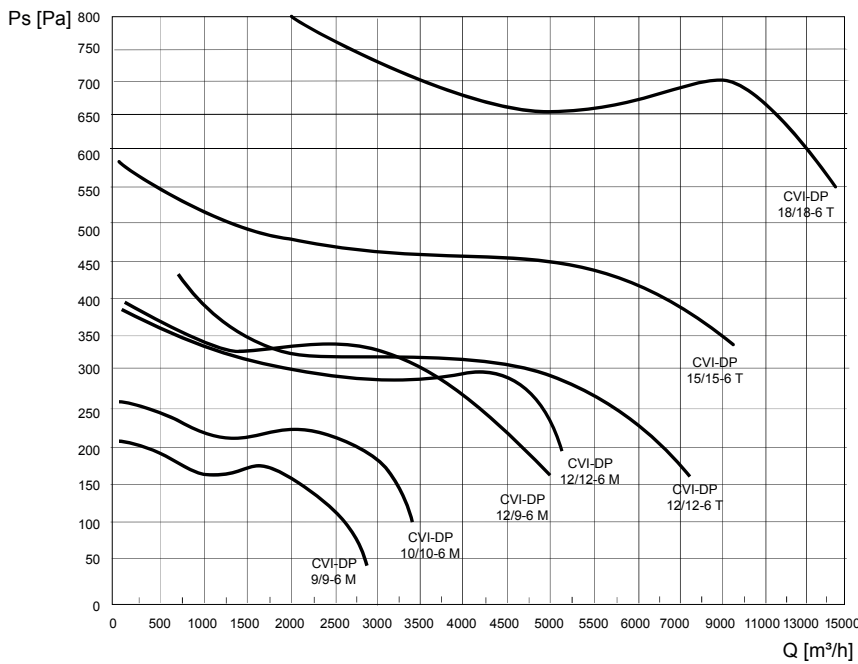
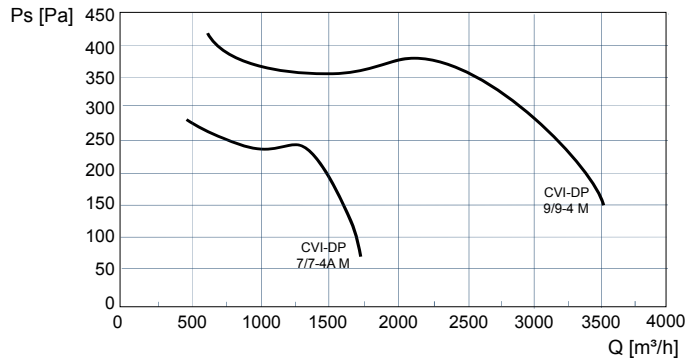

Note

The CVI-DP fan may never be used with free inlet. There should be a minimal counter-pressure as indicated above. Please measure the current at first starting.

Technical data								
	U [V]	P [W]	I [A]	SC	Tu [°C]	IP	n [rpm]	Lp, max [dB(A)]
CVI-DP 7/7-4A M	1 x 230	147	1.6	TSC-1-22	40	55	1420	59
CVI-DP 9/9-6 M	1 x 230	245	2.2	TSC-1-40	40	55	960	78
CVI-DP 9/9-4 M	1 x 230	550	4.6	TSC-1-50	40	55	1420	67
CVI-DP 10/10-6 M	1 x 230	245	2.8	TSC-1-40	40	44	980	64
CVI-DP 12/9-6 M	1 x 230	750	5.5	TSC-1-70	40	55	913	79
CVI-DP 12/12-6 M	1 x 230	1000	6.3	TSC-1-70	40	44	899	81
CVI-DP 12/12-6 T	3 x 230/400	1100	5.2 - 3	FIS-1320E-1.5-B / TSCTK-4-30	40	44	980	74
CVI-DP 15/15-6 T	3 x 230/400	2200	8.82 - 5.1	FIS-1320E-2.2-B / FIS-4420E-2.2-B	40	55	990	86

- SC = Speed controller
- Tu = Maximum ambient temperature
- Lpa = Sound pressure level

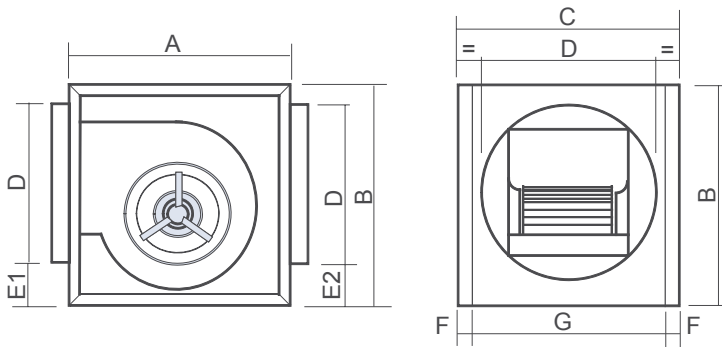

	Dimensions								
	A [mm]	B [mm]	C [mm]	D [mm]	E1 [mm]	E2 [mm]	F [mm]	G [mm]	[kg]
CVI-DP 7/7	450	450	450	250	148	148	20	410	28
CVI-DP 9/9	550	550	550	355	140	140	20	510	35
CVI-DP 10/10	600	600	600	400	154	154	20	560	39
CVI-DP 12/9	650	650	700	450	155	155	20	660	48
CVI-DP 12/12	650	650	700	450	155	155	20	660	55
CVI-DP 15/15	800	800	950	560	195	275	20	910	92