

- Aeraulic
- Actuator 5 Nm
- Proportional
- Dampers



Actuators 5Nm modulating 0-10V type LM A-SR

Servomotor for air volume control dampers of up to 1 m² depending on the type of air valve and the pressure on the valves. Simple direct mounting on the damper axe with a universal spindle clamp, supplied with an anti-rotation strap to prevent the actuator from rotating.

Brand

- Belimo

Application

- Dampers

Specifications

- Torque 5 Nm
- Nominal Voltage AC/DC 24 V
- Control: modulating standard control signal DC 0-10 V, position feedback DC 2-10 V. The measuring voltage U allows the damper position (0-100%) to be electrically indicated and serves as a follow-up control signal for other actuators

Accessoires

- Auxiliary switches, type **S1A** (1) or **S2A** (2)
- Positioners, type **SGA24 / SGF24**
- Shaft extensions, type **AV8-25**

Technical data

- Power consumption:
 1. In operation: 1 W @ nominal torque
 2. At rest: 0.2 W
 3. For wire sizing: 2 VA
- Control:
 1. Control signal Y: DC 0-10 V, typical input impedance 100 kΩ
 2. Working range: DC 2-10 V
- Position feedback (Measuring voltage): DC 2-10 V, max. 1 mA
- Position accuracy: +/- 5%
- Direction of rotation: reversible with switch 0 / 1
- Direction of rotation at Y = 0 V: at switch position 0 resp. 1
- Manual override: gearing latch disengaged with pushbutton, self-resetting

- Angle of rotation: max. 95°, limited on both sides by means of adjustable, mechanical end stops. The actuator is overload proof; requires no limit switches and automatically stops when the end stop is reached
- Running time: 150 s
- Sound power level: max. 35 dB (A)
- Degree of protection: IP54 in any mounting position

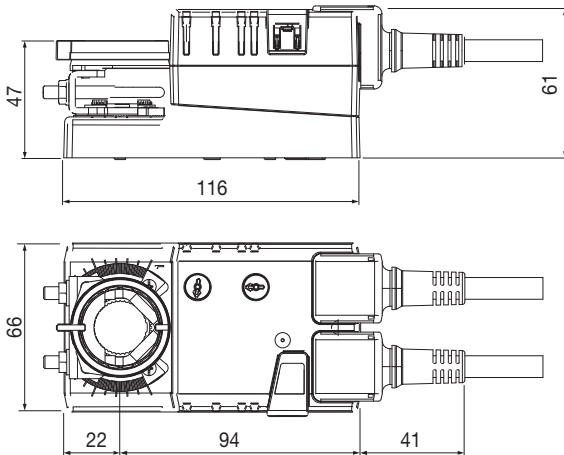

Wiring diagram

SGA24

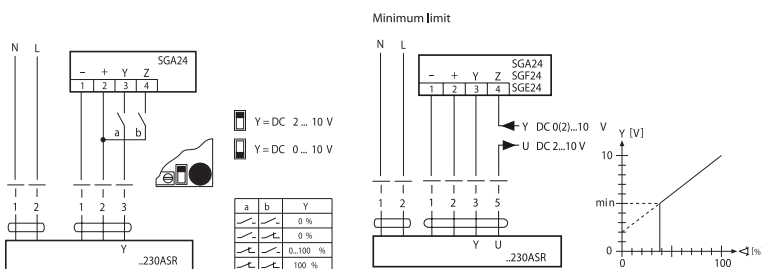
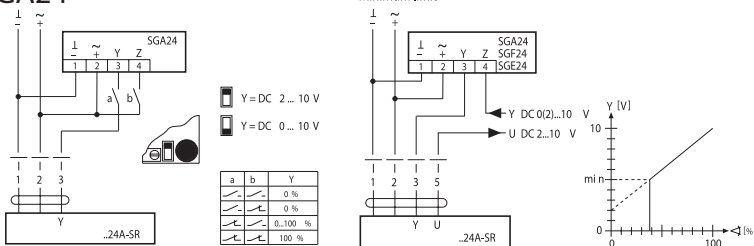

Electrical diagram

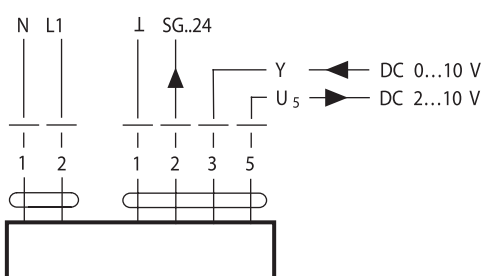

Text for tender

- The servomotor shall be of the modulating type with signal 0-10 V with torque of 5 Nm for direct mounting on the damper axle. 24V with reversible direction of rotation, angle max 95° with mechanical end stops. Protection class III safety extra-low voltage, IP 54 in any mounting position EMC: CE according to 89/336/EEC.