

UTC/UTV ASP- AIP

— Toebehoren
— Ventilclima
— UTC/UTV
— Plenums



Lucht terugname/toevoer plenums voor UTC/UTV ventilo convectoren type UTC/UTV ASP-AIP

Geïsoleerde uitblaasplenum en niet-geïsoleerde uitblaasplenums met uitsparing
voor filter en galva voor UTC/UTV toestellen

Merk

Ventilclima

Toepassing

Satelliettoestellen

Samenstelling

- Galva
- Ronde spigots in galva, diameter en aantal volgens grootte van UTC/UTV
- AIP = Niet-geïsoleerd plenum met standaard uitsparing voor filterplaatsing
- ASP = intern geïsoleerd uitblaasplenum

Versies

7 groottes met verschillende diameters en aantallen

Ordervoorbeeld

UTC/UTV-10-ASP

Uitleg

UTC/UTV = Type ventilo convector

10 = Grootte ventilo convector

ASP = Lucht toevoer plenum

AIP = Lucht terugname plenum

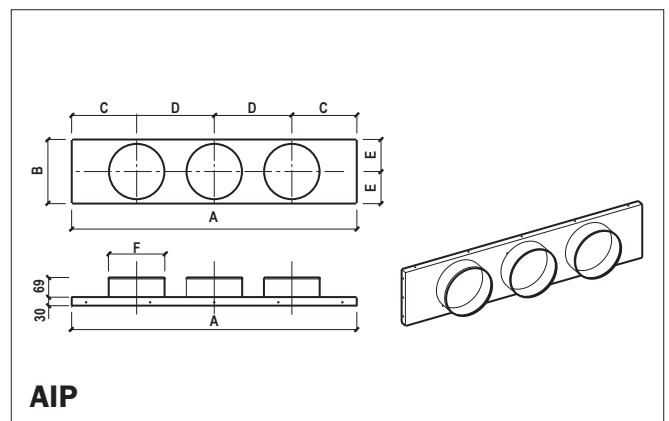
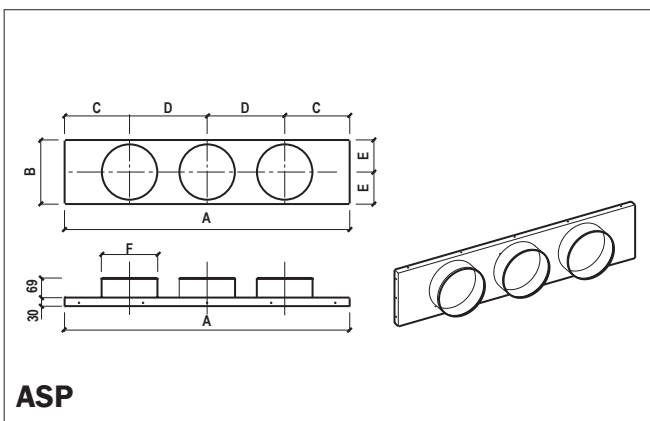
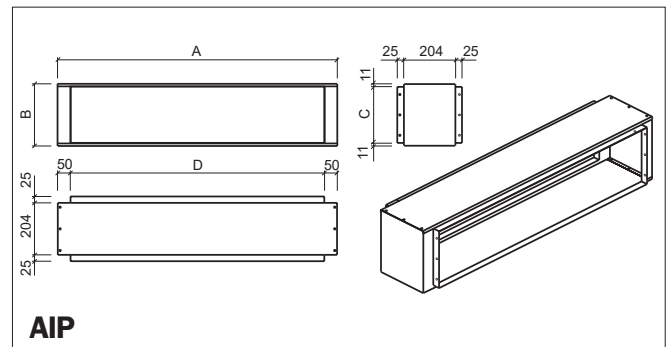
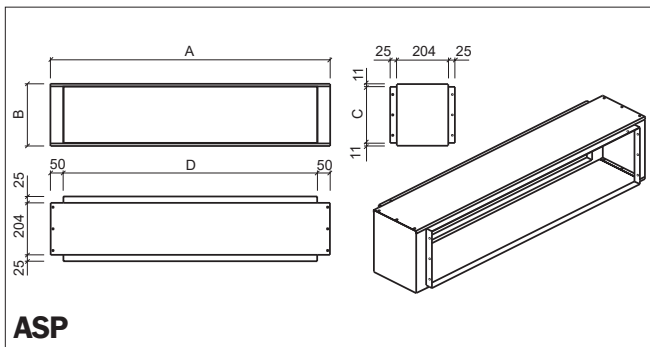

Afmetingen													
ASP							AIP						
MOD.	A	B	C	D				MOD.	A	B	C	D	
	mm	mm	mm	mm					mm	mm	mm	mm	
10	648	219	197	548				10	648	219	197	548	
20	998	219	197	898				20	998	219	197	898	
30	1098	244	222	998				30	1098	244	222	998	
40	1338	244	222	1238				40	1338	244	222	1238	
50	1338	294	272	1238				50	1338	294	272	1238	
60	1342	416	394	1242				60	1342	416	394	1242	
70	2026	416	394	1926				70	2026	416	394	1926	
ASP							AIP						
MOD.	A	B	C	D	E	F	MOD.	A	B	C	D	E	F
	mm	mm	mm	mm	mm	mm		mm	mm	mm	mm	mm	mm
10	550	200	135	280	100	2x200	10	550	200	135	280	100	2x200
20	900	200	181	270	100	3x200	20	900	200	181	270	100	3x200
30	1000	226	227	272	113	3x200	30	1000	226	227	272	113	3x200
40	1240	226	170	300	113	4x200	40	1240	226	170	300	113	4x200
50	1240	276	135	325	138	4x200	50	1240	276	135	325	138	4x200
60	1245	416	322	600	208	2x400	60	1245	416	322	600	208	2x400
70	1935	416	244	482	208	4x400	70	1935	416	244	482	208	4x400